

\$97.50



2022 **NATIONAL** **CONSTRUCTION** **ESTIMATOR**

70th Edition

Edited by Richard Pray

Includes inside the back cover:

Access all of Craftsman's most popular costbooks – subscribe to National Estimator Cloud. <https://craftsman-book.com/national-estimator-cloud>



- Turn your estimate into a bid.
- Turn your bid into a contract.
- ConstructionContractWriter.com



Craftsman Book Company
6058 Corte del Cedro, Carlsbad, CA 92011

Contents

A complete index begins on page 640

How to Use This Book	3-5	Construction Economics Division.....	307
Abbreviations and Symbols	6	Industrial & Commercial Division Labor Cost.....	309
Craft Codes and Crews	7-9	Industrial and Commercial Division.....	310-639
Residential Division Labor Cost.....	10	01 General Requirements.....	310-332
Adjusting Labor Costs	11	02 Existing Conditions.....	332-338
Area Modification Factors	12-15	03 Concrete	338-371
Credits and Acknowledgments	16	Concrete formwork	339
Residential Division	17-305	Reinforcing steel.....	346
Adhesives.....	17	Foundations.....	361
Basement doors	23	04 Masonry	371-382
Building permit fees.....	28	Reinforcing and flashing.....	372
Cabinets, kitchen.....	29	Brick and block walls.....	373
Carpentry, rule of thumb	32	05 Metals	383-389
Carpentry, assemblies.....	33	Structural steel.....	383
Carpentry, piecework rates	37	Steel floor and roof decking	384
Carpentry, detailed breakdown	39	06 Wood and Composites	389-397
Carpentry, finish work	52	Framing carpentry	389
Carpentry, steel.....	57	07 Thermal & Moisture Protection	397-412
Ceilings, suspended.....	79	Thermal insulation	398
Concrete work	84	Roof insulation.....	399
Decking	98	Membrane roofing	401
Demolition	100	08 Openings	412-423
Doors, jambs, frames, and trim.....	105	Metal doors.....	412
Electrical work, subcontract	127	Hardware	420
Elevators and lifts, subcontract	133	09 Finishes	423-440
Excavation and backfill.....	135	Gypsum wallboard.....	423
Fences.....	142	Ceilings and flooring.....	429
Fire sprinkler systems	150	10 Specialties	440-449
Flooring	153	Partitions.....	443
Framing connectors.....	159	11 Equipment	449-470
Garage doors	164	12 Furnishings.....	470-475
Glass, glazing.....	166	13 Special Construction	475-488
Gutters and downspouts	167	14 Conveying Equipment.....	488-491
Gypsum drywall and accessories	168	21 Fire Suppression.....	491-493
Hardware.....	169	22 Plumbing.....	494-535
Heating and cooling	172	Pipe and fittings.....	494
Insulation	181	Hangers and supports	516
Insurance and bonding.....	185	Valves, pumps, gauges	519
Landscaping	187	23 HVAC.....	535-541
Lighting fixtures	190	Gas fired heaters.....	535
Log home construction.....	192	Hydronic & steam heating	537
Lumber and plywood.....	194	26 Electrical.....	541-588
Markup (overhead and profit).....	208	Rigid steel conduit.....	543
Masonry.....	209	EMT conduit and wire	546
Moldings	222	PVC conduit and wire.....	551
Paint removal	233	Conduit supports & hangers.....	554
Paints, coatings, and supplies	234	Wire and cable	557
Paneling	242	Lighting.....	582
Paving	243	27 Communications	589-594
Plastering	244	31 Earthwork	594-609
Plumbing fixtures and equipment.....	245	Excavation and backfill.....	597
Plumbing and heating piping.....	251	Shoring, bulkheads, piles	605
Roofing	255	32 Exterior Improvements	609-626
Sheet metal	267	Paving and curbs.....	609
Siding	274	Fencing and gates.....	617
Skylights.....	277	33 Utilities.....	626-639
Stairs	281	Pressure water pipe	628
Taxes, Payroll.....	285	Drain pipe	631
Tile	287	Index	640
Wallcoverings.....	293		
Windows.....	297		

This Book Is an Encyclopedia of 2022 Building Costs

The **2022 National Construction Estimator** lists estimated construction costs to general contractors performing the work with their own crews, as of mid-2022. Overhead & profit are not included.

This Manual Has Two Parts; the Residential Construction Division begins on page 17. Use the figures in this division when estimating the cost of homes and apartments with a wood, steel or masonry frame. The Industrial and Commercial Division begins on page 308 and can be used to estimate costs for nearly all construction not covered by the Residential Division.

The Residential Construction Division is arranged in alphabetical order by construction trade and type of material. The Industrial and Commercial Division follows MasterFormat™ 2004. A complete index begins on page 640.

National Estimator

The software will run on PCs using Windows XP, Vista, 7, 8, or 10 operating systems.

When the National Estimator program has been installed, click Help on the menu bar to see a list of topics that will get you up and running. Or go online to www.craftsman-book.com, click on "Support", then click on "Tutorials" to view an interactive video for National Estimator.

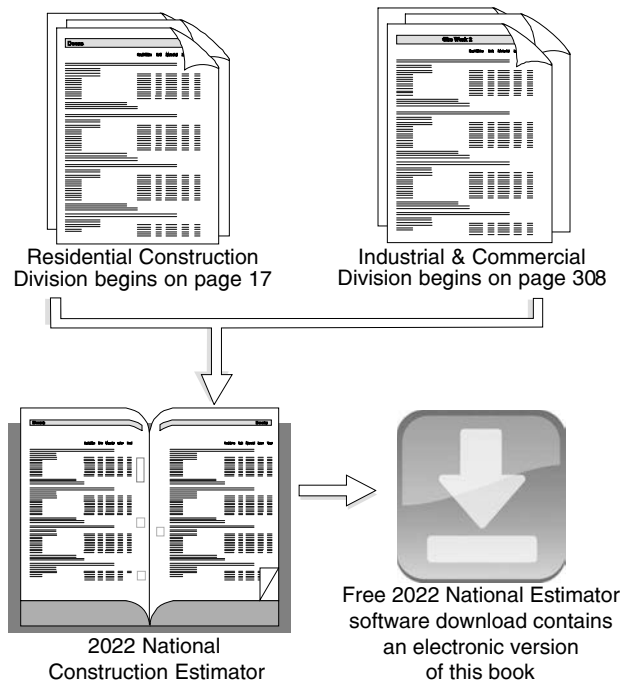

Material Costs

Material Costs for each item are listed in the column headed "Material." These are neither retail nor wholesale prices. They are estimates of what most contractors who buy in moderate volume will pay suppliers as of mid-2022. Discounts may be available for purchases in larger volume.

Quarterly prices updates on the Web are free and automatic all during 2022. You'll be prompted when it's time to collect the next update. A connection to the Web is required.

Add Delivery Expense to the material cost for other than local delivery of reasonably large quantities. Cost of delivery varies with the distance from source of supply, method of transportation, and quantity to be delivered. But most material dealers absorb the delivery cost on local delivery (5 to 15 miles) of larger quantities to good customers. Add the expense of job site delivery when it is a significant part of the material cost.

Add Sales Tax when sales tax will be charged to the contractor buying the materials.

Waste and Coverage loss is included in the installed material cost. The cost of many materials per unit after installation is greater than the purchase price for the same unit because of waste, shrinkage or coverage loss during installation. For example, about 120 square feet of nominal 1" x 4" square edge boards will be needed to cover 100 square feet of floor or wall. There is no coverage loss with plywood sheathing, but waste due to cutting and fitting will average about 6%.

Costs in the "Material" column of this book assume normal waste and coverage loss. Small and irregular jobs may require a greater waste allowance. Materials priced without installation (with no labor cost) do not include an allowance for waste and coverage except as noted.

Labor Costs

Labor Costs for installing the material or doing the work described are listed in the column headed "Labor." The labor cost per unit is the labor cost per hour multiplied by the manhours per unit shown after the @ sign in the "Craft@Hours" column. Labor cost includes the basic wage, the employer's contribution to welfare, pension, vacation and apprentice funds and all tax and insurance charges based on wages. Hourly labor costs for the various crafts are listed on page 10 (for the Residential Division) and page 309 (for the Industrial and Commercial Division).

Hourly labor costs used in the Industrial and Commercial Division are higher than those used in the

Residential Division, reflecting the fact that craftsmen on industrial and commercial jobs are often paid more than craftsmen on residential jobs.

Supervision Expense to the general contractor is not included in the labor cost. The cost of supervision and non-productive labor varies widely from job to job. Calculate the cost of supervision and non-productive labor and add this to the estimate.

Payroll Taxes and Insurance included in the labor cost are itemized in the sections beginning on pages 185 and 285.

Manhours per Unit and the Craft performing the work are listed in the "Craft@Hrs" column. Pages 7 through 9 explain the "Craft@Hrs" column. To find the units of work done per man in an 8-hour day, divide 8 by the manhours per unit. To find the units done by a crew in an 8-hour day, multiply the units per man per 8-hour day by the number of crew members.

Manhours Include all productive labor normally associated with installing the materials described. This will usually include tasks such as:

- Unloading and storing construction materials, tools and equipment on site.
- Moving tools and equipment from a storage area or truck on site at the beginning of the day.
- Returning tools and equipment to a storage area or truck on site at the end of the day.
- Normal time lost for work breaks.
- Planning and discussing the work to be performed.
- Normal handling, measuring, cutting and fitting.
- Keeping a record of the time spent and work done.
- Regular cleanup of construction debris.
- Infrequent correction or repairs required because of faulty installation.

Adjust the Labor Cost to the job you are figuring when your actual hourly labor cost is known or can be estimated. The labor costs listed on pages 10 and 309 will apply within a few percent on many jobs. But labor costs may be much higher or much lower on the job you are estimating.

If the hourly wage rates listed on page 10 or page 309 are not accurate, divide your known or estimated cost per hour by the listed cost per hour. The result is your adjustment for any figure in the "Labor" column for that craft. See page 11 for more information on adjusting labor costs.

Adjust for Unusual Labor Productivity. Costs in the labor column are for normal conditions: experienced craftsmen working on reasonably well planned and managed new construction with fair to good productivity. Labor estimates assume that materials are standard grade, appropriate tools are on hand, work done by other crafts is adequate, layout and installation

are relatively uncomplicated, and working conditions don't slow progress.

Working conditions at the job site have a major effect on labor cost. Estimating experience and careful analysis can help you predict the effect of most changes in working conditions. Obviously, no single adjustment will apply on all jobs. But the adjustments that follow should help you produce more accurate labor estimates. More than one condition may apply on a job.

- Add 10% to 15% when working temperatures are below 40 degrees or above 95 degrees.
- Add 15% to 25% for work on a ladder or a scaffold, in a crawl space, in a congested area or remote from the material storage point.
- Deduct 10% when the work is in a large open area with excellent access and good light.
- Add 1% for each 10 feet that materials must be lifted above ground level.
- Add 5% to 50% for tradesmen with below average skills. Deduct 5% to 25% for highly motivated, highly skilled tradesmen.
- Deduct 10% to 20% when an identical task is repeated many times for several days at the same site.
- Add 30% to 50% on small jobs where fitting and matching of materials is required, adjacent surfaces have to be protected and the job site is occupied during construction.
- Add 25% to 50% for work done following a major flood, fire, earthquake, hurricane or tornado while skilled tradesmen are not readily available. Material costs may also be higher after a major disaster.
- Add 10% to 35% for demanding specs, rigid inspections, unreliable suppliers, a difficult owner or an inexperienced architect.

Use an Area Modification Factor from pages 12 through 15 if your material, hourly labor or equipment costs are unknown and can't be estimated.

Here's how: Use the labor and material costs in this manual without modification. Then add or deduct the percentage shown on pages 12 through 15 to estimated costs to find your local estimated cost.

Equipment Costs

Equipment Costs for major equipment (such as cranes and tractors) are listed in the column headed "Equipment." Costs for small tools and expendable supplies (such as saws and tape) are usually considered overhead expense and do not appear in the Equipment cost column.

Equipment costs are based on rental rates listed in the section beginning on page 320 and assume that the equipment can be used productively for an entire 8-hour day. Add the cost of moving equipment on and off the site. Allow for unproductive time when equipment can't be used for the full rental period. For example, the equipment costs per unit of work completed will be higher when a tractor is used for 4 hours during a day and sits idle for the remaining 4 hours. Generally, an 8-hour day is the minimum rental period for most heavy equipment. Many sections describe the equipment being used, the cost per hour and a suggested minimum job charge.

Subcontracted Work

Subcontractors do most of the work on construction projects. That's because specialty contractors can often get the work done at competitive cost, even after adding overhead and profit.

Many sections of this book cover work usually done by subcontractors. If you see the word "subcontract" in a section description, assume that costs are based on quotes by subcontractors and include typical subcontractor markup (about 30% on labor and 15% on material). Usually no material or labor costs will appear in these sections. The only costs shown will be in the "Total" column and will include all material, labor and equipment expense.

If you don't see the word "subcontract" in a section description, assume that costs are based on work done by a general contractor's crew. No markup is included in these costs. If the work is done by a subcontractor, the specialty contractor may be able to perform the work for the cost shown, even after adding overhead and profit.

Markup

The General Contractor's Markup is not included in any costs in this book. On page 208 we suggest a 20% markup on the contract price for general contractors handling residential construction. Apply this markup or some figure you select to all costs, including both subcontract items and work done by your own crews.

To realize a gross profit of 20% on the contract price, you'll have to mark up costs by 25%. See page 208 for an example of how markup is calculated. Markup includes overhead and profit and may be the most difficult item to estimate.

Keep In Mind

Labor and Material Costs Change. Costs were compiled in the fall of 2021 and projected to mid-2022 based on recent price trends. These estimates will be accurate for some materials and inaccurate for others. No one can predict every change in material prices.

How Accurate Are These Figures? As accurate as possible considering that the estimators who wrote this book don't know your subcontractors or material suppliers, haven't seen the plans or specifications, don't know what building code applies or where the job is, had to project material costs at least 6 months into the future, and had no record of how much work the crew that will be assigned to the job can handle.

You wouldn't bid a job under those conditions. And we don't claim that all construction is done at these prices.

Estimating Is an Art, not a science. On many jobs the range between high and low bid will be 20% or more. There's room for legitimate disagreement on what the correct costs are, even when complete plans and specifications are available, the date and site are established, and labor and material costs are identical for all bidders.

No cost fits all jobs. Good estimates are custom made for a particular project and a single contractor through judgment, analysis and experience.

This book is not a substitute for judgment, analysis and sound estimating practice. It's an aid in developing an informed opinion of cost. If you're using this book as your sole cost authority for contract bids, you're reading more into these pages than the editors intend.

Use These Figures to compile preliminary estimates, to check your costs and subcontract bids and when no actual costs are available. This book will reduce the chance of error or omission on bid estimates, speed "ball park" estimates, and be a good guide when there's no time to get a quote.

Where Do We Get These Figures? From the same sources all professional estimators use: contractors and subcontractors, architectural and engineering firms, material suppliers, material price services, analysis of plans, specifications, estimates and completed project costs, and both published and unpublished cost studies. In addition, we conduct nationwide mail and phone surveys and have the use of several major national estimating databases.



We'll Answer Your Questions about any part of this book and explain how to apply these costs.

Free telephone assistance is available from 8 a.m. until 5 p.m. California time Monday through Friday except holidays. Phone 760-438-7828 x 2.

We don't accept collect calls and won't estimate the job for you. But if you need clarification on something in this manual, we can help.

Abbreviations

AASHO	American Assn. of State Highway Officials	FAA	Federal Aviation Administration	OC	spacing from center to center
ABS	acrylonitrile butadiene styrene	FICA	Federal Insurance Contributions Act (Social Security, Medicare tax)	OD	outside diameter
AC	alternating current	FOB	freight on board	OS & Y	outside screw & yoke
AISC	American Institute of Steel Construction Inc.	FPM	feet per minute	oz	ounce
APP	attactic polypropylene	FRP	fiberglass reinforced plastic	perf	perforated
ASHRAE	American Society of Heating, Refrigerating and Air Conditioning Engineers	FS	Federal Specification	Pr	pair
ASME	American Society of Mechanical Engineers	ft-lbs	foot pounds	PSF	pounds per square foot
ASTM	American Society for Testing Materials	FUTA	Federal Unemployment Compensation Act Tax	PSI	pounds per square inch
AWPA	American Wood Products Association	Gal	gallon	PV	photovoltaic
AWWA	American Water Works Association	GFCI	ground fault circuit interruptor	PVC	polyvinyl chloride
Ba	bay	GPH	gallon(s) per hour	Qt	quart
Bdle	bundle	GPM	gallon(s) per minute	R	thermal resistance
BF	board foot	H	height	R/L	random length(s)
BHP	boiler horsepower	HP	horsepower	R/W/L	random widths and lengths
Btr	better	Hr(s)	hour(s)	RPM	revolutions per minute
Btu	British thermal unit	IMC	intermediate metal conduit	RSC	rigid steel conduit
B & W	black & white	ID	Inside diameter	S1S2E	surfaced 1 side, 2 edges
C	thermal conductance	KD	kiln dried or knocked down	S2S	surfaced 2 sides
C	one hundred	KSI	kips per square inch	S4S	surfaced 4 sides
CF	cubic foot	KV	kilovolt(s)	Sa	sack
CFM	cubic feet per minute	KVA	1,000 volt amps	SBS	styrene butyl styrene
CLF	100 linear feet	kw	kilowatt(s)	SDR	size to diameter ratio
cm	centimeter	kwh	kilowatt hour	SF	square foot
CPE	chlorinated polyethylene	L	length	SFCA	square feet of form in contact with concrete
CPM	cycles per minute	Lb(s)	pound(s)	Sq	100 square feet
CPVC	chlorinated polyvinyl chloride	LF	linear foot	SSB	single strength B quality glass
CSPE	chloro sulphinated polyethylene	LP	liquified propane	STC	sound transmission class
CSF	100 square feet	LS	lump sum	Std	standard
CSY	100 square yards	M	one thousand	SY	square yard
CY	cubic yard	Mb	million bytes (characters)	T	thick
d	penny	MBF	1,000 board feet	T&G	tongue & groove edge
D	depth	MBtu	1,000 British thermal units	TV	television
DC	direct current	MCM	1,000 circular mils	UBC	Uniform Building Code
dia	diameter	MDO	medium density overlaid	UL	Underwriter's Laboratory
DSB	double strength B quality glass	MH	manhour	USDA	United States Dept. of Agriculture
DWV	drain, waste, vent piping	Mi	mile	VLF	vertical linear foot
Ea	each	MLF	1,000 linear feet	W	width
EMT	electric metallic tube	MPH	miles per hour	Wk	week
EPDM	ethylene propylene diene monomer	mm	millimeter(s)	W/	with
equip.	equipment	Mo	month	x	by or times
exp.	exposure	MSF	1,000 square feet		
F	Fahrenheit	NEMA	National Electrical Manufacturer's Association		
		NFPA	National Fire Protection Association		
		No.	number		
		NRC	noise reduction coefficient		

Symbols

/	per
—	through or to
@	at
%	per 100 or percent
\$	U.S. dollars
'	feet
"	inches
#	pound or number

Craft Codes, Hourly Costs and Crew Compositions

Both the Residential Division and Commercial and Industrial Division of this book include a column titled Craft@Hrs. Letters and numbers in this column show our estimates of:

- Who will do the work (the craft code)
- An @ symbol which means at
- How long the work will take (manhours).

For example, on page 51 you'll find estimates for installing BC plywood wall sheathing by the square foot. The Craft@Hrs column opposite ½" plywood wall sheathing shows:

B1@.016

That means we estimate the installation rate for crew B1 at .016 manhours per square foot. That's the same as 16 manhours per 1,000 square feet.

The table that follows defines each of the craft codes used in this book. Notice that crew B1 is composed of two craftsmen: one laborer and one carpenter.

To install 1,000 square feet of ½" BC wall sheathing at .016 manhours per square foot, that crew would need 16 manhours (one 8-hour day for a crew of two).

Notice also in the table below that the cost per manhour for crew B1 is listed as \$34.11. That's the average for a residential laborer (listed at \$30.55 per hour on page 10) and a residential carpenter (listed at \$37.66 per hour): \$30.55 plus \$37.66 is \$68.21. Divide by 2 to get \$34.105 (rounded up to \$34.11), the average cost per manhour for crew B1.

In the table below, the cost per manhour is the sum of hourly costs of all crew members divided by the number of crew members. That's the average cost per manhour.

Costs in the Labor column in this book are the installation time (in manhours) multiplied by the cost per manhour. For example, on page 51 the labor cost listed for ½" BC wall sheathing is \$0.55 per square foot. That's the installation time (.016 manhours per square foot) multiplied by \$34.11, the average cost per manhour for crew B1.

Residential Division

Craft Code	Cost Per Manhour	Crew Composition	Craft Code	Cost Per Manhour	Crew Composition
B1	\$34.11	1 laborer and 1 carpenter	BR	\$36.31	1 lather
B2	\$35.29	1 laborer, 2 carpenters	BS	\$33.60	1 marble setter
B3	\$32.92	2 laborers, 1 carpenter	CF	\$35.88	1 cement mason
B4	\$37.77	1 laborer 1 operating engineer 1 reinforcing iron worker	CT	\$35.68	1 mosaic & terrazzo worker
B5	\$37.37	1 laborer, 1 carpenter 1 cement mason 1 operating engineer 1 reinforcing iron worker	D1	\$37.04	1 drywall installer 1 drywall taper
B6	\$33.22	1 laborer, 1 cement mason	DI	\$36.81	1 drywall installer
B7	\$31.15	1 laborer, 1 truck driver	DT	\$37.27	1 drywall taper
B8	\$36.82	1 laborer 1 operating engineer	HC	\$29.64	1 plasterer helper
B9	\$33.36	1 bricklayer 1 bricklayer's helper	OE	\$43.09	1 operating engineer
BB	\$38.31	1 bricklayer	P1	\$37.22	1 laborer, 1 plumber
BC	\$37.66	1 carpenter	PM	\$43.89	1 plumber
BE	\$41.03	1 electrician	PP	\$34.56	1 painter, 1 laborer
BF	\$34.59	1 floor layer	PR	\$37.75	1 plasterer
BG	\$36.45	1 glazier	PT	\$38.57	1 painter
BH	\$28.40	1 bricklayer's helper	R1	\$36.22	1 roofer, 1 laborer
BL	\$30.55	1 laborer	RI	\$39.66	1 reinforcing iron worker
			RR	\$41.89	1 roofer
			SW	\$42.53	1 sheet metal worker
			T1	\$33.28	1 tile layer, 1 laborer
			TL	\$36.00	1 tile layer
			TR	\$31.74	1 truck driver

Commercial and Industrial Division

Craft Code	Cost Per Manhour	Crew Composition	Craft Code	Cost Per Manhour	Crew Composition
A1	\$51.56	1 asbestos worker 1 laborer	F6	\$49.63	2 carpenters, 2 laborers 1 tractor operator
AT	\$44.49	1 air tool operator	F7	\$51.63	2 carpenters, 1 laborer 1 tractor operator
AW	\$61.46	1 asbestos worker	F8	\$52.20	2 plasterers 1 plasterer's helper
BM	\$62.24	1 boilermaker	F9	\$46.77	1 laborer, 1 floor layer
BT	\$41.81	1 bricklayer tender	FL	\$51.87	1 floor layer
C1	\$42.66	4 laborers, 1 truck driver	G1	\$48.86	1 glazier, 1 laborer
C2	\$50.12	1 laborer, 2 truck drivers 2 tractor operators	H1	\$54.91	1 carpenter, 1 laborer 1 iron worker (structural) 1 tractor operator
C3	\$48.71	1 laborer, 1 truck driver 1 tractor operator	H2	\$52.34	1 crane operator 1 truck driver
C4	\$43.33	2 laborers, 1 truck driver	H3	\$47.20	1 carpenter, 3 laborers 1 crane operator 1 truck driver
C5	\$46.95	2 laborers, 1 truck driver 1 tractor operator	H4	\$63.07	1 crane operator 6 iron workers (structural) 1 truck driver
C6	\$45.89	6 laborers, 2 truck drivers 2 tractor operators	H5	\$54.92	1 crane operator 2 iron workers (structural) 2 laborers
C7	\$48.45	2 laborers , 3 truck drivers 1 crane operator 1 tractor operator	H6	\$54.15	1 iron worker (structural) 1 laborer
C8	\$47.60	1 laborer, 1 carpenter	H7	\$63.76	1 crane operator 2 iron workers (structural)
C9	\$49.83	1 laborer, 1 crane operator	H8	\$61.87	1 crane operator 4 iron workers (structural) 1 truck driver
CB	\$54.55	1 bricklayer	H9	\$61.14	1 electrician 1 sheet metal worker
CC	\$53.53	1 carpenter	IW	\$66.64	1 iron worker (structural)
CD	\$52.81	1 drywall Installer	LA	\$48.42	1 lather
CE	\$61.01	1 electrician	M1	\$48.18	1 bricklayer 1 bricklayer's tender
CG	\$56.06	1 glazier	M2	\$45.62	1 carpenter, 2 laborers
CL	\$41.66	1 laborer	M3	\$50.59	1 plasterer 1 plasterer's helper
CM	\$51.84	1 cement mason	M4	\$48.19	1 laborer, 1 marble setter
CO	\$58.00	1 crane operator	M5	\$52.37	1 pipefitter, 1 laborer,
CV	\$57.79	1 elevator constructor	M6	\$55.40	1 asbestos worker 1 laborer, 1 pipefitter
D2	\$47.24	1 drywall installer 1 laborer	M8	\$57.73	3 pipefitters, 1 laborer
D3	\$54.23	1 laborer, 1 iron worker (structural), 1 millwright	M9	\$62.05	1 electrician, 1 pipefitter
D4	\$48.03	1 laborer, 1 millwright	MI	\$55.94	2 pipefitters, 1 laborer
D5	\$51.95	1 boilermaker, 1 laborer	MS	\$54.71	marble setter
D6	\$55.52	2 millwrights 1 tractor operator	MT	\$51.59	mosaic & terrazzo worker
D7	\$47.72	1 painter, 1 laborer	MW	\$54.39	millwright
D9	\$50.15	2 millwrights, 1 laborer			
E1	\$52.63	2 electricians, 2 laborers 1 tractor operator			
E2	\$51.34	2 electricians, 2 laborers			
E3	\$52.07	2 electricians, 2 laborers 2 carpenters			
E4	\$51.34	1 electrician, 1 laborer			
F5	\$48.78	3 carpenters, 2 laborers			

Commercial and Industrial Division

Craft Code	Cost Per Manhour	Crew Composition	Craft Code	Cost Per Manhour	Crew Composition
P5	\$45.89	3 laborers 1 tractor operator 1 truck driver	S8	\$51.54	2 pile drivers, 2 laborers 1 truck driver 1 crane operator 1 tractor operator
P6	\$52.91	1 laborer, 1 plumber			
P8	\$46.75	1 laborer, 1 cement mason	S9	\$49.05	1 pile driver, 2 laborers 1 tractor operator 1 truck driver
P9	\$49.01	1 carpenter, 1 laborer 1 cement mason			
PA	\$53.78	1 painter	SM	\$61.26	1 sheet metal worker
PD	\$57.48	1 pile driver	SP	\$65.47	1 sprinkler fitter
PF	\$63.08	1 pipefitter	SS	\$51.41	1 laborer 2 tractor operators
PH	\$45.73	1 plasterer's helper			
PL	\$64.16	1 plumber	T2	\$53.65	3 laborers, 3 carpenters 3 iron workers (structural) 1 crane operator 1 truck driver
PS	\$55.44	1 plasterer			
R3	\$47.17	2 roofers, 1 laborer			
RB	\$65.75	1 reinforcing iron worker			
RF	\$49.93	1 roofer	T3	\$53.71	1 laborer 1 reinforcing iron worker
S1	\$49.73	1 laborer 1 tractor operator	T4	\$46.63	1 laborer, 1 mosaic worker
S3	\$52.24	1 truck driver 1 tractor operator	T5	\$51.46	1 sheet metal worker 1 laborer
S4	\$41.66	3 laborers	T6	\$54.73	2 sheet metal workers 1 laborer
S5	\$44.71	5 laborers 1 crane operator 1 truck driver	TD	\$46.68	1 truck driver
S6	\$47.04	2 laborers 1 tractor operator	TO	\$57.79	1 tractor operator
S7	\$49.73	3 laborers 3 tractor operators	U1	\$51.32	1 plumber, 2 laborers 1 tractor operator
			U2	\$49.16	1 plumber, 2 laborers

Residential Division

	1	2	3	4	5	6
Craft	Base wage per hour	Taxable fringe benefits (@5.59% of base wage)	Insurance and employer taxes (%)	Insurance and employer taxes (\$)	Non-taxable fringe benefits (@4.94% of base wage)	Total hourly cost used in this book
Bricklayer	\$28.04	\$1.57	24.68%	\$7.31	\$1.39	\$38.31
Bricklayer's Helper	20.79	1.16	24.68	5.42	1.03	28.40
Building Laborer	21.22	1.19	31.64	7.09	1.05	30.55
Carpenter	26.38	1.47	30.54	8.51	1.30	37.66
Cement Mason	26.67	1.49	22.72	6.40	1.32	35.88
Drywall installer	27.30	1.53	23.00	6.63	1.35	36.81
Drywall Taper	27.64	1.55	23.00	6.71	1.37	37.27
Electrician	31.28	1.75	19.53	6.45	1.55	41.03
Floor Layer	25.60	1.43	23.32	6.30	1.26	34.59
Glazier	26.61	1.49	25.06	7.04	1.31	36.45
Lather	27.39	1.53	20.90	6.04	1.35	36.31
Marble Setter	25.32	1.42	20.98	5.61	1.25	33.60
Millwright	26.83	1.50	20.87	5.91	1.33	35.57
Mosaic & Terrazzo Worker	26.89	1.50	20.98	5.96	1.33	35.68
Operating Engineer	31.57	1.77	24.58	8.19	1.56	43.09
Painter	28.31	1.58	24.34	7.28	1.40	38.57
Plasterer	27.01	1.51	27.70	7.90	1.33	37.75
Plasterer Helper	21.20	1.19	27.70	6.20	1.05	29.64
Plumber	32.34	1.81	23.83	8.14	1.60	43.89
Reinforcing Ironworker	28.35	1.59	27.80	8.32	1.40	39.66
Roofer	27.00	1.51	42.26	12.05	1.33	41.89
Sheet Metal Worker	30.97	1.73	25.37	8.30	1.53	42.53
Sprinkler Fitter	31.78	1.78	24.55	8.24	1.57	43.37
Tile Layer	27.13	1.52	20.98	6.01	1.34	36.00
Truck Driver	23.08	1.29	25.58	6.23	1.14	31.74

Hourly Labor Cost

The labor costs shown in Column 6 were used to compute the manhour costs for crews on page 7 and the figures in the "Labor" column of the Residential Division of this manual. Figures in the "Labor" column of the Industrial and Commercial Division of this book were computed using the hourly costs shown on page 309. All labor costs are in U.S. dollars per manhour.

It's important that you understand what's included in the figures in each of the six columns above. Here's an explanation:

Column 1, the base wage per hour, is the craftsman's hourly wage. These figures are representative of

what many contractors will be paying craftsmen working on residential construction in 2022.

Column 2, taxable fringe benefits, includes vacation pay, sick leave and other taxable benefits. These fringe benefits average 5.59% of the base wage for many construction contractors. This benefit is in addition to the base wage.

Column 3, insurance and employer taxes in percent, shows the insurance and tax rate for construction trades. The cost of insurance in this column includes workers' compensation and contractor's casualty and liability coverage. Insurance rates vary widely from state to state and depend on a contractor's loss experience. Typical rates are shown in the Insurance section

of this manual beginning on page 185. Taxes are itemized in the section on page 285. Note that taxes and insurance increase the hourly labor cost by 30 to 35% for most trades. There is no legal way to avoid these costs.

Column 4, insurance and employer taxes in dollars, shows the hourly cost of taxes and insurance for each construction trade. Insurance and taxes are paid on the costs in both columns 1 and 2.

Column 5, non-taxable fringe benefits, includes employer paid non-taxable benefits such as medical coverage and tax-deferred pension and profit sharing plans. These fringe benefits average 4.94% of the base wage for many construction contractors. The employer pays no taxes or insurance on these benefits.

Column 6, the total hourly cost in dollars, is the sum of columns 1, 2, 4, and 5.

These hourly labor costs will apply within a few percent on many jobs. But wage rates may be much higher or lower in some areas. If the hourly costs shown in column 6 are not accurate for your work, develop modification factors that you can apply to the labor costs in this book. The following paragraphs explain the procedure.

Adjusting Labor Costs

Here's how to customize the labor costs in this book if your wage rates are different from the wage rates shown on page 10 or 309.

Start with the taxable benefits you offer. Assume craftsmen on your payroll get one week of vacation each year and one week of sick leave each year. Convert these benefits into hours. Your computation might look like this:

$$\begin{array}{r} 40 \text{ vacation hours} \\ + 40 \text{ sick leave hours} \\ \hline 80 \text{ taxable leave hours} \end{array}$$

Then add the regular work hours for the year:

$$\begin{array}{r} 2,000 \text{ regular hours} \\ + 80 \text{ taxable benefit hours} \\ \hline 2,080 \text{ total hours} \end{array}$$

Multiply these hours by the base wage per hour. If you pay carpenters \$20.00 per hour, the calculation would be:

$$\begin{array}{r} 2,080 \text{ hours} \\ \times \$20.00 \text{ per hour} \\ \hline \$41,600 \text{ per year} \end{array}$$

Next, determine the tax and insurance rate for each trade. If you know the rates that apply to your jobs, use those rates. If not, use the rates in column 3 on page 10.

Continuing with our example, we'll use 30.54%, the rate for carpenters in column 3 on page 10. To increase the annual taxable wage by 30.54%, we'll multiply by 1.3054:

$$\begin{array}{r} \$41,600 \text{ per year} \\ \times 1.3054 \text{ tax \& insurance rate} \\ \hline \$54,305 \text{ annual cost} \end{array}$$

Then add the cost of non-taxable benefits. Suppose your company has no pension or profit sharing plan but does provide medical insurance for employees. Assume that the cost for your carpenter is \$343.67 per month or \$4,124 per year.

$$\begin{array}{r} \$4,124 \text{ medical plan} \\ + 54,305 \text{ annual cost} \\ \hline \$58,429 \text{ total annual cost} \end{array}$$

Divide this total annual cost by the actual hours worked in a year. This gives the contractor's total hourly labor cost including all benefits, taxes and insurance. Assume your carpenter will work 2,000 hours a year:

$$\frac{\$58,429}{2,000} = \$29.21 \text{ per hour}$$

Finally, find your modification factor for the labor costs in this book. Divide your total hourly labor cost by the total hourly labor cost shown on page 10. For the carpenter in our example, the figure in column 6 is \$37.66.

$$\frac{\$29.21}{\$37.66} = .776$$

Your modification factor is 77.6%. Multiply any building carpenter (Craft Code BC) labor costs in the Residential Division of this book by .776 to find your estimated cost. For example, on page 24 the labor cost for installing an 18" long towel bar is \$10.50 per each bar. If installed by your carpenter working at \$20.00 per hour, your estimated cost would be 77.6% of \$10.50 or \$8.15. The manhours would remain the same @.280, assuming normal productivity.

If the Labor Rate Is Unknown

On some estimates you may not know what labor rates will apply. In that case, use both labor and material figures in this book without making any adjustment. When all labor, equipment and material costs have been compiled, add or deduct the percentage shown in the area modification table on pages 12 through 15.

Adjusting the labor costs in this book will make your estimates much more accurate.

Area Modification Factors

Construction costs are higher in some areas than in other areas. Add or deduct the percentages shown on the following pages to adapt the costs in this book to your job site. Adjust your cost estimate by the appropriate percentages in this table to find the estimated cost for the site selected. Where 0% is shown, it means no modification is required.

Modification factors are listed alphabetically by state and province. Areas within each state are listed alphabetically. For convenience, one representative city is identified in each three-digit zip or range of zips. Percentages are based on the average of all data points in the table. Factors listed for each state and province are the average of all data points in that state

or province. Figures for three-digit zips are the average of all five-digit zips in that area. Figures in the Total column are the weighted average of factors for Labor, Material and Equipment.

The National Estimator Cloud program at <https://craftsman-book.com/national-estimator-cloud> will apply an area modification factor for any five-digit zip you select. Click the Area Cost Modification icon on the program tool bar.

These percentages are composites of many costs and will not necessarily be accurate when estimating the cost of any particular part of a building. But when used to modify costs for an entire structure, they should improve the accuracy of your estimates.

Location	Zip	Mat.	Lab.	Equip.	Total Wtd. Avg.	Location	Zip	Mat.	Lab.	Equip.	Total Wtd. Avg.	Location	Zip	Mat.	Lab.	Equip.	Total Wtd. Avg.
Alabama Average						Alaska Average						District of Columbia Average					
Anniston	362	-3	-13	-1	-8%	Anchorage	995	16	38	5	26%	Washington	200-205	2	23	1	12%
Auburn	368	-1	-8	0	-4%	Fairbanks	997	16	40	5	27%	Florida Average					
Bellamy	369	-2	13	-1	5%	Juneau	998	18	20	6	19%	Altamonte Springs	327	-1	-6	0	-3%
Birmingham	350-352	-3	8	-1	2%	Ketchikan	999	3	36	1	18%	Bradenton	342	0	-12	0	-6%
Dothan	363	-1	-13	0	-7%	King Salmon	996	16	32	5	23%	Brooksville	346	0	-16	0	-7%
Evergreen	364	-2	-20	-1	-10%	Arizona Average						Daytona Beach	321	-2	-18	-1	-9%
Gadsden	359	-4	-15	-1	-9%	Chambers	865	1	-19	0	-8%	Fort Lauderdale	333	3	1	1	2%
Huntsville	358	1	-3	0	-1%	Douglas	855	0	-18	0	-8%	Fort Myers	339	0	-12	0	-6%
Jasper	355	-2	-16	-1	-8%	Flagstaff	860	2	-17	1	-7%	Fort Pierce	349	-2	-20	-1	-10%
Mobile	365-366	-1	-3	0	-2%	Kingman	864	1	-11	0	-5%	Gainesville	326	-1	-18	0	-9%
Montgomery	360-361	-1	-3	0	-2%	Mesa	852	1	5	0	3%	Jacksonville	322	-1	-3	0	-2%
Scottsboro	357	0	-8	0	-4%	Phoenix	850	1	6	0	3%	Lakeland	338	-3	-13	-1	-8%
Selma	367	-1	-10	0	-5%	Prescott	863	3	-16	1	-6%	Melbourne	329	-2	-15	-1	-8%
Sheffield	356	-1	1	0	0%	Show Low	859	2	-18	1	-7%	Miami	330-332	2	-1	1	1%
Tuscaloosa	354	1	-9	0	-4%	Tucson	856-857	0	-10	0	-5%	Naples	341	3	-8	1	-2%
Alaska Average						Colorado Average						Ocala	344	-3	-23	-1	-12%
Anchorage	995	16	38	5	26%	Aurora	800-801	3	11	1	7%	Orlando	328	0	2	0	1%
Fairbanks	997	16	40	5	27%	Boulder	803-804	3	5	1	4%	Panama City	324	-2	-21	-1	-11%
Juneau	998	18	20	6	19%	Colorado Springs	808-809	2	-3	1	0%	Pensacola	325	-1	-17	0	-8%
Ketchikan	999	3	36	1	18%	Denver	802	3	13	1	8%	Saint Augustine	320	-1	-4	0	-2%
King Salmon	996	16	32	5	23%	Durango	813	1	-3	0	-1%	Saint Cloud	347	0	-5	0	-2%
Arizona Average						Connecticut Average						St Petersburg	337	0	-12	0	-6%
Chambers	865	1	-19	0	-8%	Bridgeport	066	0	13	0	6%	Tallahassee	323	0	-13	0	-6%
Douglas	855	0	-18	0	-8%	Bristol	060	1	24	0	12%	Tampa	335-336	-1	-1	0	-1%
Flagstaff	860	2	-17	1	-7%	Fairfield	064	2	17	1	9%	West Palm Beach	334	1	-5	0	-2%
Kingman	864	1	-11	0	-5%	Hartford	061	0	23	0	11%	Georgia Average					
Mesa	852	1	5	0	3%	New Haven	065	1	15	0	7%	Albany	317	-2	-10	-1	-6%
Phoenix	850	1	6	0	3%	Norwich	063	0	7	0	3%	Athens	306	0	-11	0	-5%
Prescott	863	3	-16	1	-6%	Stamford	068-069	4	21	1	12%	Atlanta	303	3	23	1	12%
Show Low	859	2	-18	1	-7%	Waterbury	067	1	12	0	6%	Augusta	308-309	-2	-2	-1	-2%
Tucson	856-857	0	-10	0	-5%	West Hartford	062	1	9	0	5%	Buford	305	0	-5	0	-2%
Yuma	853	0	5	0	2%	Delaware Average						Calhoun	307	-1	-19	0	-9%
Arkansas Average						Dover	199	1	-9	0	-4%	Columbus	318-319	-1	-6	0	-3%
Batesville	725	0	-20	0	-9%	Newark	197	2	10	1	6%	Dublin/Fort Valley	310	-3	-13	-1	-8%
Camden	717	-4	1	-1	-2%	Wilmington	198	0	9	0	4%	Hinesville	313	-2	-11	-1	-6%
Fayetteville	727	0	-8	0	-4%	Florida Average						Kings Bay	315	-2	-19	-1	-10%
Fort Smith	729	-1	-14	0	-7%	Altamonte Springs	327	-1	-6	0	-3%	Macon	312	-2	-7	-1	-4%
Harrison	726	-1	-25	0	-12%	Bradenton	342	0	-12	0	-6%	Marietta	300-302	1	8	0	4%
Hope	718	-3	-15	-1	-8%	Brooksville	346	0	-16	0	-7%	Savannah	314	-1	-7	0	-4%
Hot Springs	719	-2	-25	-1	-13%	Daytona Beach	321	-2	-18	-1	-9%	Statesboro	304	-2	-21	-1	-11%
Jonesboro	724	-1	-18	0	-9%	Fort Lauderdale	333	3	1	1	2%	Valdosta	316	-1	-1	0	-1%
Little Rock	720-722	-1	-6	0	-3%	Fort Myers	339	0	-12	0	-6%	Hawaii Average					
Pine Bluff	716	-4	-19	-1	-11%	Fort Pierce	349	-2	-20	-1	-10%	Aliamanu	968	17	29	6	22%
Russellville	728	0	-9	0	-4%	Gainesville	326	-1	-18	0	-9%	Ewa	967	17	23	6	20%
West Memphis	723	-3	-1	-1	-2%	Jacksonville	322	-1	-3	0	-2%	Halawa Heights	967	17	23	6	20%
California Average						Lakeland	338	-3	-13	-1	-8%	Hilo	967	17	23	6	20%
Alhambra	917-918	3	15	1	8%	Melbourne	329	-2	-15	-1	-8%	Honolulu	968	17	29	6	22%
Bakersfield	932-933	1	4	0	2%	Miami	330-332	2	-1	1	1%	Kailua	968	17	29	6	22%
El Centro	922	1	-1	0	0%	Naples	341	3	-8	1	-2%	Luualualei	967	17	23	6	20%
Eureka	955	1	13	0	7%	Ocala	344	-3	-23	-1	-12%	Mililani Town	967	17	23	6	20%
Fresno	936-938	0	-5	0	-2%	Orlando	328	0	2	0	1%	Pearl City	967	17	23	6	20%
Herlong	961	2	17	1	9%	Panama City	324	-2	-21	-1	-11%	Wahiawa	967	17	23	6	20%
Inglewood	902-905	3	16	1	9%	Pensacola	325	-1	-17	0	-8%	Waianae	967	17	23	6	20%
Irvine	926-927	3	24	1	13%	Saint Augustine	320	-1	-4	0	-2%	Wailuku (Maui)	967	17	23	6	20%
Lompoc	934	3	2	1	3%	Saint Cloud	347	0	-5	0	-2%						

Credits and Acknowledgments

This book has over 30,000 cost estimates for 2022. To develop these estimates, the editors relied on information supplied by hundreds of construction cost authorities. We offer our sincere thanks to the contractors, engineers, design professionals, construction estimators, material suppliers and manufacturers who, in the spirit of cooperation, have assisted in the preparation of this Seventieth Edition of the National Construction Estimator. Many of the cost authorities who supplied information for this volume are listed below.

AFCO Roofing Supply, John Ording
Amerec Products, Jim Haas
American Arbitration Assoc., Kerstin Norlin
Anthem Contracting, Joe Caronna
Bell Blueprint, Paul Moore
Cement Cutting, Inc., Matt Becker
Dial One, Charlie Gindele
Fiorentine Company, Tom Forsyth
Groundwater Data, Inc., John Kratz
H&H Specialties, Reid Neslage
Iron-A-Way Company, Reg Smidt
J.H. Baxter, Inc., Dean Rogers
KEL-EEZ Weatherstripping, James Adams
Marbleworks of San Diego, Charlene Butler
Mel-Northey Co., Mel Northey
On Time Appraisal, Ralph Kinney
Prof. Photographic Service, Larry Hoagland
RCP Block & Brick Co., Gina Adams
San Diego Gas & Electric, Don Altevers
Superior Rock Products, John Knieff
U. S. Gypsum Company, Roger Merchet
West Coast Lumber Inspect. Bur., Jim Kneaper
Weyerhaeuser Company, Doug Barkee
York Spiral Stair, Jim A. Guerette
Daniel Atcheson

A special thanks to the following people. Special assistants to the editors: Ray Hicks, James Thomson.
Layout & Images: Christine Pray. Software production: Bilandra Chase.

Cover design: Jennifer Johnson

Photos: iStock by Getty Images™

Adhesives

Adhesives See also, Caulking, Flooring, Roofing and Tile in the Residential Division

Panel adhesives Better quality, gun applied in continuous bead to wood or metal framing or furring members, material only, add labor below. Per 100 SF of wall, floor, or ceiling including 6% waste.

	Unit	Bead diameter			
		1/8"	1/4"	3/8"	1/2"
Subfloor adhesive, on floors					
12" OC members	CSF	2.77	11.10	25.00	44.40
16" OC members	CSF	2.08	8.32	18.70	33.30
20" OC members	CSF	1.66	6.66	15.00	26.60
24" OC members	CSF	1.39	5.55	12.50	22.20
Wall sheathing or shear panel adhesive, on walls					
12" OC members	CSF	3.76	15.00	33.80	60.20
16" OC members	CSF	2.82	11.30	25.40	45.10
20" OC members	CSF	2.26	9.02	20.30	36.10
24" OC members	CSF	1.88	7.52	16.90	30.10
Polystyrene or polyurethane foam panel adhesive, on walls					
12" OC members	CSF	3.55	14.20	32.00	56.90
16" OC members	CSF	2.67	10.70	24.00	42.70
20" OC members	CSF	2.13	8.53	19.20	34.10
24" OC members	CSF	1.78	7.11	16.00	28.40
Gypsum drywall adhesive					
12" OC members	CSF	1.34	5.37	12.10	21.50
16" OC members	CSF	1.01	4.03	9.06	16.10
20" OC members	CSF	.81	3.22	7.25	12.90
24" OC members	CSF	.67	2.68	6.04	10.70
Hardboard or plastic panel adhesive, on walls					
12" OC members	CSF	4.09	16.40	36.80	65.40
16" OC members	CSF	3.07	12.30	27.60	49.10
20" OC members	CSF	2.45	9.81	22.10	39.20
24" OC members	CSF	2.04	8.17	18.40	32.70

	Craft@Hrs	Unit	Material	Labor	Total
Labor to apply adhesive to framing members, 1/8" to 1/2" bead diameter, no material included					
Floor or ceiling joists					
12" OC members	BC@.075	CSF	—	2.82	2.82
16" OC members	BC@.056	CSF	—	2.11	2.11
20" OC members	BC@.052	CSF	—	1.96	1.96
24" OC members	BC@.042	CSF	—	1.58	1.58
Interior and exterior wall members					
12" OC members	BC@.100	CSF	—	3.77	3.77
16" OC members	BC@.090	CSF	—	3.39	3.39
20" OC members	BC@.084	CSF	—	3.16	3.16
24" OC members	BC@.084	CSF	—	3.16	3.16

Special purpose adhesives

Construction adhesive, for counters, cabinets, paneling, brick veneer, ceramic fixtures, shelving, sets in 10 minutes, 10.5 oz. cartridge	—	Ea	1.67	—	1.67
Epoxy-tie adhesive, bonds concrete, fills cracks to 3/4", seals doors and windows, anchor grouting, non-shrink, 22 oz. cartridge	—	Ea	34.10	—	34.10
Gypsum drywall adhesive, waterproof, bonds to wood, metal, masonry, concrete, 29 oz. cartridge	—	Ea	4.53	—	4.53

Aggregate

	Craft@Hrs	Unit	Material	Labor	Total
Latex FRP adhesive, indoor, bonds wood, concrete, drywall, foamboard, trowel grade, gallon	—	Ea	21.70	—	21.70
Panel insulation adhesive, waterproof, for polyurethane & polystyrene panels, bonds to wood, metal, masonry, concrete, 4.5 lbs.	—	Ea	38.70	—	38.70
Marine adhesive/sealant, 10 oz.	—	Ea	26.00	—	26.00
Project adhesive, rubber-based, bonds plywood, hardboard fiberglass, drywall, foam board, shelving, ceramic fixtures, 10 minute work time, 10.5 oz. cartridge	—	Ea	4.11	—	4.11
		Unit		1 quart can	1 gallon can
General purpose adhesives					
Acoustic tile adhesive, solvent base, waterproof, sound deadening type		Ea		—	14.90
Aliphatic resin woodworking glue		Ea		14.10	37.40
Carpet cement, outdoor		Ea		21.90	—
Professional carpenter's glue, multi-purpose		Ea		17.10	36.40
Contact cement, rubber based, waterproof, bonds veneers to plywood, particleboard, wallboard		Ea		16.60	40.60
Gel contact cement		Ea		15.90	—
Resilient flooring adhesive, latex base, adheres to concrete, plywood, felt, sheet flooring		Ea		6.38	18.00
Tile cement, solvent base, ceramic/stone, interior		Ea		7.93	25.30

	Craft@Hrs	Unit	Material	Labor	Total
Aggregate Typical prices, 5 mile haul, 24 ton minimum. See also Roofing, Built-up					
Crushed stone (1.4 tons per CY)					
3/8" stone	—	Ton	24.10	—	24.10
3/4" (Number 3)	—	Ton	22.70	—	22.70
1-1/2" (Number 2)	—	Ton	21.70	—	21.70
Crushed slag, typical prices where available					
3/4" slag	—	Ton	23.60	—	23.60
1-1/2"	—	Ton	24.10	—	24.10
Washed gravel (1.4 tons per CY)					
3/4" gravel	—	Ton	43.40	—	43.40
1-1/2"	—	Ton	45.80	—	45.80
Pea gravel, (1.4 tons per CY), typical prices where available					
3/8" or 1/2"	—	Ton	50.70	—	50.70
Sand, (1.35 tons per CY), typical prices where available					
Fill sand	—	Ton	28.90	—	28.90
Mason sand	—	Ton	39.70	—	39.70
Concrete sand	—	Ton	34.50	—	34.50
Add per ton less than 24 tons	—	Ton	8.00	—	8.00
Add for delivery over 5 miles, one way	—	Mile	10.00	—	10.00

Appraisal Fees Costs for determining the value of existing buildings, land, and equipment. Actual fee charged is based on the level of difficulty and the time spent on appraisal plus travel to location and cost of support services, if any. Costs include research and report by a professional state licensed appraiser. Client may request an appraisal on a "fee not to exceed" basis. Fees shown are averages and are not quoted as a percentage of value or contingent on value. The fee for cancelling an appraisal after the inspection is equal to the original appraisal fee.

Appraisal and Arbitration Fees

	Craft@Hrs	Unit	Material	Labor	Total
Single family residences, condominiums, planned unit developments (PUDs). Fees for complex, expensive (over \$1 million) or atypical properties or those that require higher licensure than a state license are usually negotiated. Based on square feet of gross living area (excluding the garage).					
To 2,500 square feet	—	LS	—	—	397.00
Over 2,500 SF to 3,500 SF	—	LS	—	—	450.00
Over 3,500 SF to 5,000 SF	—	LS	—	—	556.00
Over 5,000 SF	—	LS	—	—	821.00
Small residential income properties (duplex, triplex, quadriplex)					
2 to 4 units	—	LS	—	—	715.00
Apartment houses, commercial and industrial buildings					
To \$300,000 valuation	—	LS	—	—	3,440.00
Over \$300,000 to \$1,000,000 valuation	—	LS	—	—	4,500.00
Over \$1,000,000 to \$3,000,000 valuation	—	LS	—	—	5,030.00
Over \$3,000,000 to \$5,000,000 valuation	—	LS	—	—	6,350.00
Other services					
Additional photograph (each)	—	LS	—	—	29.10
Outlying area fee	—	LS	—	—	58.20
Satisfactory Completion (old Form 442 / new Form 1004d)	—	LS	—	—	159.00
Appraisal update, same comps (Form 1004d)	—	LS	—	—	318.00
Operating Income Statement (FNMA 216)	—	LS	—	—	84.70
SFR Rental Survey (FNMA 1007)	—	LS	—	—	84.70
Appraisal review (desk)	—	LS	—	—	185.00
Appraisal review (field)	—	LS	—	—	397.00
Drive-by appraisal (Form 2055) starting at	—	LS	—	—	291.00
Drive-by appraisal (Form 2070/2075)	—	LS	—	—	238.00
Machinery (Fee is based on total value of equipment appraised) Additional charges for travel and lodging may be required					
To \$30,000 valuation	—	LS	—	—	656.00
Over \$30,000 to \$100,000 valuation	—	LS	—	—	879.00
Over \$100,000 to \$500,000 valuation	—	LS	—	—	1,480.00
Over \$500,000 to \$1,000,000 valuation	—	LS	—	—	2,010.00
Over \$1,000,000 to \$5,000,000 valuation	—	LS	—	—	3,440.00
Court testimony (excluding preparation)	—	Day	—	—	1,590.00
Consulting fees billed at an hourly rate	—	Hour	—	—	201.00
Outside of office meetings or court appearance are billed including travel time and expenses round trip, minimum 4 hours.					

Arbitration and Mediation Fees These are administrative fees paid to the American Arbitration Association (AAA). Rules and fees are subject to change. The AAA's web site at www.adr.org has current rules and fee information. Fees charged by Construction Dispute Resolution Services (<http://www.constructiondisputes-cdrs.com>) will usually be less. Arbitrators are chosen from the National Roster of Construction Arbitrators and are paid a fee by the parties. Legal representation, if desired (although not necessary), is at the expense of each party. These fees do not include rental of a hearing room. An initial filing fee is payable in full by a filing party when a claim, counterclaim or additional claim is filed. A case service fee is payable at the time the first hearing is scheduled. This fee will be refunded at the conclusion of the case if no hearings have occurred so long as the Association was notified of cancellation at least 24 hours before the first scheduled hearing. The minimum AAA filing fee for any case having three or more arbitrators is \$2,750 plus a \$1,000 case service fee.

Arbitration and Mediation Fees

	Unit	Initial Filing Fee	Case Service Fee
Claims to \$75,000	LS	750.00	800.00
Claims over \$75,000 to \$150,000	LS	1,750.00	1,250.00
Claims over \$150,000 to \$300,000	LS	2,650.00	2,000.00
Claims over \$300,000 to \$500,000	LS	4,000.00	3,500.00
Claims over \$500,000 to \$1,000,000	LS	5,000.00	6,200.00
Claims over \$1,000,000 to \$10,000,000	LS	7,000.00	7,700.00
Claims over \$10,000,000 *	LS	*	12,500.00
No Amount Stated **	LS	7,000.00	7,700.00

* \$10 million and above – Base fee is \$10,000 plus .01% of the amount of claim above \$10 million. Filing fees are capped at \$65,000.

**This fee is applicable when a claim or counterclaim is not for a monetary amount. Where a monetary claim is not known, parties will be required to state a range of claims or be subject to the highest possible filing fee.

*** Fees above based upon a 'Standard Fee Schedule' For 'Flexible Fee Schedule' costs, add 10% to the total of Initial and Case Service Fees.

Craft@Hrs Unit Material Labor Total

Mediation, mobile Generally will meet at the offices of the attorneys involved in the dispute. Does not replace legal counsel but is used to maintain equity between the mediating parties. Typical fees.

Nonrefundable retainer (half from each party)	—	Ea	—	—	380.00
Weekday sessions after the initial consultation	—	Hr	—	—	191.00
Nonrefundable retainer for weekend mediation	—	Ea	—	—	460.00
Weekend mediation sessions	—	Hr	—	—	287.00

Architectural Illustrations Full color painting on watercolor board with matted frame with title and credit on matte. Glass and elaborate framing are extra. Costs for pen and ink illustrations with color Mylar overlay are similar to cost for watercolor illustrations. Typical fees.



Custom home, eye level view					
Simple rendering	—	LS	—	—	1,020.00
Complex rendering	—	LS	—	—	1,490.00
Custom home, bird's eye view					
Simple rendering	—	LS	—	—	1,230.00
Complex rendering	—	LS	—	—	1,760.00
Tract homes in groups of five or more (single floor plans, multiple elevations), eye level view					
Simple rendering	—	LS	—	—	602.00
Complex rendering	—	LS	—	—	828.00
Tract homes in groups of five or more (single floor plans, multiple elevations), bird's eye view					
Simple rendering	—	LS	—	—	775.00
Complex rendering	—	LS	—	—	1,250.00
Tract homes or condominium project, overall bird's eye view					
10-25 homes or living units	—	LS	—	—	3,830.00
Typical commercial structure					
Eye level view	—	LS	—	—	1,720.00
Bird's eye view	—	LS	—	—	1,920.00
Complex commercial structure					
Eye level view	—	LS	—	—	2,530.00
Bird's eye view	—	LS	—	—	3,270.00

Awnings and Canopies

	Craft@Hrs	Unit	Material	Labor	Total
Deduct for pen and ink drawings (no color)	—	%	—	—	-33.0
Computer generated perspective drawings using CAD system for design studies					
Custom home	—	LS	—	—	649.00
Large condo or apartment projects	—	LS	—	—	1,630.00
Tract homes	—	LS	—	—	408.00
Commercial structure, line drawing	—	LS	—	—	1,230.00

Awnings and Canopies for Doors and Windows All hardware included. For commercial grade awnings, see the Industrial and Commercial Division section 12, Furnishings.

Aluminum pan-type window or door awnings, 025 gauge roof and pans, .040 gauge supports

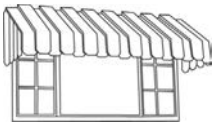

42" wide x 24" projection, 18" drop	SW@2.17	Ea	390.00	92.30	482.30
60" wide x 30" projection, 20" drop	SW@2.79	Ea	562.00	119.00	681.00
78" wide x 36" projection, 24" drop	SW@3.11	Ea	777.00	132.00	909.00
88" wide x 42" projection, 26" drop	SW@3.41	Ea	930.00	145.00	1,075.00

Polycarbonate door awnings, clear or tinted curved poly sheet in aluminum frame, 29" projection, 11" drop



61" wide	SW@2.18	Ea	310.00	92.70	402.70
119" wide	SW@6.21	Ea	370.00	264.00	634.00
178" wide	SW@8.72	Ea	440.00	371.00	811.00

Roll-up aluminum awnings with hinged support arms and pull cord assembly

36" wide x 18" projection, 27" drop	SW@2.28	Ea	283.00	97.00	380.00
48" wide x 24" projection, 34" drop	SW@2.91	Ea	327.00	124.00	451.00
54" wide x 30" projection, 39" drop	SW@3.29	Ea	336.00	140.00	476.00
60" wide x 35" projection, 44" drop	SW@3.50	Ea	355.00	149.00	504.00
72" wide x 42" projection, 51" drop	SW@4.20	Ea	416.00	179.00	595.00

Curved top door or window canopy, rigid aluminum frame with tinted or clear polycarbonate inserts.



59" wide x 46" projection, 16" drop	BC@3.40	Ea	632.00	128.00	760.00
84" wide x 46" projection, 16" drop	BC@5.10	Ea	883.00	192.00	1,075.00
120" wide x 57" projection, 16" drop	BC@6.80	Ea	1,560.00	256.00	1,816.00

Mansard window or door awnings, 24 gauge 18"-wide standing seam steel panels, aluminum frame

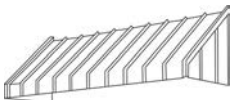

54" wide x 36" projection, 36" drop	BC@3.40	Ea	1,300.00	128.00	1,428.00
72" wide x 36" projection, 36" drop	BC@4.50	Ea	1,730.00	169.00	1,899.00
90" wide x 36" projection, 36" drop	BC@5.60	Ea	2,160.00	211.00	2,371.00
108" wide x 48" projection, 48" drop	BC@6.70	Ea	2,950.00	252.00	3,202.00

Fabric door awning, with waterproof, acrylic duck, colorfast fabric, double stitched seams, tubular aluminum frame

36" wide x 26" projection	SW@1.45	Ea	264.00	61.70	325.70
40" wide x 36" projection	SW@1.86	Ea	290.00	79.10	369.10
48" wide x 40" projection	SW@2.07	Ea	313.00	88.00	401.00
72" wide x 46" projection	SW@2.27	Ea	414.00	96.50	510.50

Cloth retractable patio awning, folding spring loaded aluminum arm, dual cable manual operation.

16' wide x 12' projection	BC@3.05	Ea	4,790.00	115.00	4,905.00
20' wide x 12' projection	BC@3.40	Ea	6,000.00	128.00	6,128.00

Barricades, Construction Safety

	Craft@Hrs	Unit	Material	Labor	Total
Barricades, Construction Safety Purchase prices except as noted. See also Equipment Rental in the index.					
Heavy Duty Plastic Type I barricade, Engineer Grade Reflectivity, 8" height Top Panel					
Quantities from 1 - 15 units	—	Ea	49.00	—	49.00
Quantities from 16 - 31 units	—	Ea	46.00	—	46.00
Pallet quantities, multiples of 32 units	—	Ea	43.60	—	43.60
Reflectorized injected plastic barricade, NCHRP-350 certified meets M.U.T.C.D. specifications 8" to 12" wide rail, 4" to 6" wide stripes, 40" legs, no light					
Type I, 2' wide, 3' high, Top panel 12" height, 1 reflectorized rail each side					
Quantities from 1 - 15 units	—	Ea	55.50	—	55.50
Quantities from 16 - 31 units	—	Ea	52.40	—	52.40
Pallet quantities, multiples of 32 units	—	Ea	49.80	—	49.80
Type II, 2' wide, 3' high, Top panel 8" height, 1 reflectorized rail each side					
Quantities from 1 - 15 units	—	Ea	61.50	—	61.50
Quantities from 16 - 31 units	—	Ea	58.10	—	58.10
Pallet quantities, multiples of 32 units	—	Ea	55.10	—	55.10
Type III, 4' wide, 5' high, 3 reflectorized rails each side, wood & steel legs					
Quantities from 1 - 15 units	—	Ea	149.00	—	149.00
Quantities from 16 - 31 units	—	Ea	146.00	—	146.00
Pallet quantities, multiples of 32 units	—	Ea	143.00	—	143.00
Add for lighted units without batteries (batteries last 2 months)					
Amber lens	—	Ea	19.40	—	19.40
Red lens	—	Ea	19.40	—	19.40
Batteries, 6 volt (2 needed)	—	Ea	9.00	—	9.00
Utility barricade lights, solar powered Utility barricade solar powered lights, compliant with M.U.T.C.D. Specification 6E-5 and ITE Specifications for Flashing / Steady Burn warning light, 180 degree swivel base axis.					
Utility barricade solar powered lights	—	Ea	44.60	—	44.60
Miscellaneous signage/traffic control					
"Road Closed", reflectorized, 30" x 48", Engineer Grade					
	—	Ea	95.40	—	95.40
"Construction Zone", 4' x 4' high intensity grade					
	—	Ea	261.00	—	261.00
High-rise tripod with 3 orange flags					
	—	Ea	213.00	—	213.00
Flags					
	—	Ea	4.05	—	4.05
Traffic cones, PVC					
Non-reflectorized type					
18" high	—	Ea	6.75	—	6.75
28" high	—	Ea	10.50	—	10.50
Reflectorized type					
18" high	—	Ea	10.50	—	10.50
28" high	—	Ea	17.60	—	17.60
36" high	—	Ea	22.90	—	22.90
Lane delineator, 42" orange plastic cylinder with 2 reflectors on a 12 pound rubber base					
	—	Ea	22.50	—	22.50
Mesh signs, orange, 48" x 48", includes brace and clamp					
	—	Ea	70.00	—	70.00
Hand-held traffic paddles, "Stop" and "Slow"					
	—	Ea	25.50	—	25.50

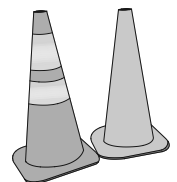
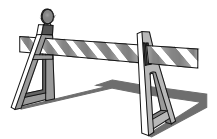

Basement Doors

	Craft@Hrs	Unit	Material	Labor	Total
Orange plastic safety fencing					
Budget, 4' x 50' roll, mesh opening 3" x 1.25"	—	Ea	26.70	—	26.70
Square mesh, 4' x 50' roll, opening 1.5" x 1.25"	—	Ea	27.00	—	27.00
Heavy Duty, 4' x 50' roll, opening 1.25" x 1.25"	—	Ea	51.90	—	51.90
Medium Weight 4' x 100', opening 2" x 2.5"	—	Ea	48.40	—	48.40
Barricade tape for marking construction sites, landscaping, wet paint					
Yellow plastic 3" x 1,000', "Caution"	—	Ea	9.00	—	9.00
Various colors, 3" x 200', "Danger"	—	Ea	6.00	—	6.00

Utility Highway Barricade Rental

Lighted units, rental, per day	—	Ea	12.00	—	12.00
Unlighted units, rental per day	—	Ea	8.00	—	8.00
Add for pickup and delivery, per trip	—	Ea	50.00	—	50.00
Typical labor cost, place and remove any barricade					
Per use	BL@.160	Ea	—	4.89	4.89

Basement Doors Good quality 12 gauge primed steel, center opening basement doors. Costs include assembly and installation hardware. No concrete, masonry, anchor placement or finish painting included.

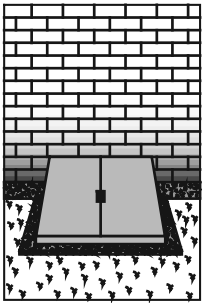

Doors (overall dimensions)					
Classic Series standard, all sizes	BC@3.41	Ea	816.00	128.00	944.00
SLW Series standard, all sizes	BC@3.41	Ea	796.00	128.00	924.00
Add for powder coating	—	%	28.4	—	—
Ultra Series, polyethylene, all sizes	BC@3.41	Ea	1,240.00	128.00	1,368.00
Add for keyed lock	BC@.160	Ea	82.30	6.03	88.33
Door extensions (available for 19-1/2"H, 55"W, 72"L door only)					
6" deep	BC@1.71	Ea	218.00	64.40	282.40
12" deep	BC@1.71	Ea	264.00	64.40	328.40
18" deep	BC@1.71	Ea	310.00	64.40	374.40

Stair stringers, steel, pre-cut for 2" x 10" wood treads (without treads). Price is for a pair, or set of two stringers with hardware.

32" to 39" stair height	BC@1.71	Pr	163.00	64.40	227.40
48" to 55" stair height	BC@1.71	Pr	218.00	64.40	282.40
56" to 64" stair height	BC@1.71	Pr	257.00	64.40	321.40
65" to 72" stair height	BC@1.71	Pr	282.00	64.40	346.40
73" to 78" stair height	BC@1.71	Pr	381.00	64.40	445.40
81" to 88" stair height	BC@1.71	Pr	412.00	64.40	476.40
89" to 97" stair height	BC@1.71	Pr	441.00	64.40	505.40

Bathroom Accessories Average quality. Better quality brass accessories cost 75% to 100% more. See also Medicine Cabinets and Vanities

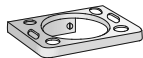

Cup and toothbrush holder, chrome	BC@.258	Ea	14.10	9.72	23.82
Cup holder, porcelain, surface mounted	BC@.258	Ea	9.85	9.72	19.57
Cup, toothbrush & soap holder, recessed	BC@.258	Ea	37.30	9.72	47.02
Cup, toothbrush holder, polished brass	BC@.258	Ea	19.90	9.72	29.62



Electrical plates, chrome plated					
Switch plate, single	BE@.154	Ea	5.22	6.32	11.54
Switch plate, double	BE@.154	Ea	6.89	6.32	13.21
Duplex receptacle plate	BE@.154	Ea	5.22	6.32	11.54
Duplex receptacle and switch	BE@.154	Ea	6.87	6.32	13.19

Bathroom Accessories

	Craft@Hrs	Unit	Material	Labor	Total
Grab bars					
Tubular chrome plated, with anchor plates					
Straight bar, 16"	BC@.414	Ea	30.60	15.60	46.20
Straight bar, 24"	BC@.414	Ea	37.30	15.60	52.90
Straight bar, 32"	BC@.414	Ea	40.40	15.60	56.00
"L"- shaped bar, 16" x 32"	BC@.620	Ea	93.80	23.30	117.10
Stainless steel, with anchor plates					
Straight bar, 16"	BC@.414	Ea	46.30	15.60	61.90
Straight bar, 24"	BC@.414	Ea	55.70	15.60	71.30
Straight bar, 32"	BC@.414	Ea	60.70	15.60	76.30
"L"- shaped bar, 16" x 32"	BC@.620	Ea	130.00	23.30	153.30
Mirrors, stainless steel framed, surface mount, no light or cabinet					
16" high x 20" wide	BG@.420	Ea	84.70	15.30	100.00
18" high x 24" wide	BG@.420	Ea	98.30	15.30	113.60
18" high x 36" wide	BG@.420	Ea	150.00	15.30	165.30
24" high x 36" wide	BG@.420	Ea	176.00	15.30	191.30
48" high x 24" wide	BG@.420	Ea	218.00	15.30	233.30
Mirrors, wood framed, surface mount, better quality					
18" x 29" rectangular	BG@.420	Ea	105.00	15.30	120.30
20" x 27" oval, oak	BG@.420	Ea	149.00	15.30	164.30
Robe hook					
Chrome	BC@.258	Ea	27.50	9.72	37.22
Double, solid brass	BC@.258	Ea	26.50	9.72	36.22
Shower curtain rods, chrome plated					
60", recessed	BC@.730	Ea	32.10	27.50	59.60
66", recessed	BC@.730	Ea	35.40	27.50	62.90
Soap holder, surface mounted, with drain holes					
Williamsburg, satin chrome	BC@.258	Ea	65.60	9.72	75.32
Polished brass	BC@.258	Ea	21.40	9.72	31.12
Facial tissue holder, stainless steel, recessed	BC@.258	Ea	44.10	9.72	53.82
Toilet tissue roll holder, chrome, recessed	BC@.258	Ea	20.60	9.72	30.32
Toothbrush holder, chrome, surface mount	BC@.258	Ea	7.60	9.72	17.32
Towel bars, 3/4" bar					
18" long, chrome	BC@.280	Ea	16.90	10.50	27.40
24" long, chrome	BC@.280	Ea	20.00	10.50	30.50
30" long, chrome	BC@.280	Ea	23.70	10.50	34.20
36" long, chrome	BC@.280	Ea	26.90	10.50	37.40
18" long, solid brass	BC@.280	Ea	54.80	10.50	65.30
24" long, solid brass	BC@.280	Ea	57.70	10.50	68.20
Towel rack, swing-arm, chrome, 3 bars, 12" L	BC@.280	Ea	19.20	10.50	29.70
Towel rings					
Williamsburg chrome and brass	BC@.280	Ea	51.90	10.50	62.40
Williamsburg chrome and porcelain	BC@.280	Ea	49.70	10.50	60.20
Towel shelf, chrome, 24" L with bar below	BC@.280	Ea	48.60	10.50	59.10
Heated towel racks, 16" and 24" width, mounted on wall with brackets. Direct wire connection, 700 watt output. Add for electrical work					
26" high, 16" wide, standard colors	BE@.850	Ea	808.00	34.90	842.90
26" high, 24" wide, standard colors	BE@.850	Ea	863.00	34.90	897.90
26" high, 24" wide, chrome finish	BE@.850	Ea	2,660.00	34.90	2,694.90

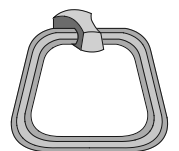
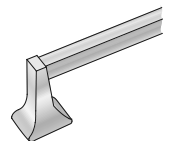

Blueprinting

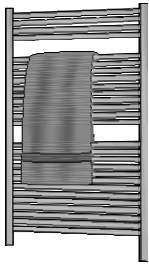

	Craft@Hrs	Unit	Material	Labor	Total
35" high, 16" wide, standard colors	BE@1.00	Ea	1,010.00	41.00	1,051.00
35" high, 24" wide, standard colors	BE@1.00	Ea	959.00	41.00	1,000.00
35" high, 24" wide, chrome finish	BE@1.00	Ea	3,220.00	41.00	3,261.00
44" high, 16" wide, standard colors	BE@1.10	Ea	1,010.00	45.10	1,055.10
44" high, 24" wide, standard colors	BE@1.10	Ea	1,070.00	45.10	1,115.10
44" high, 24" wide, chrome finish	BE@1.10	Ea	3,520.00	45.10	3,565.10
Add for direct wire w/ control panel	BE@.100	Ea	222.00	4.10	226.10
Add for wall plug in	BE@.100	Ea	298.00	4.10	302.10
Heated towel rack accessories					
Programmable control panel	BE@.250	Ea	289.00	10.30	299.30
Pull out drying racks	BE@.250	Ea	81.10	10.30	91.40
Robe knobs	BE@.150	Ea	52.50	6.15	58.65
Towel bar accents with standard colors	BE@.150	Ea	104.00	6.15	110.15
Towel bar accents with chrome finish	BE@.150	Ea	140.00	6.15	146.15
Robe knob accents (all styles)	BE@.150	Ea	242.00	6.15	248.15
Tub or shower chairs					
Wall-hung elevated fixed seat	BE@.750	Ea	39.80	30.80	70.60
White adjustable seat	BE@.750	Ea	74.20	30.80	105.00

Beds, Folding Concealed-in-wall type. Steel framed, folding wall bed system. Bed requires 18-5/8" or 22" deep recess. Includes frame, lift mechanism, all hardware. Installed in framed opening. Padded vinyl headboard. Bed face panel accepts paint, wallpaper, vinyl or laminate up to 1/4" thick. Box spring and mattress not included. Murphy Wall Beds

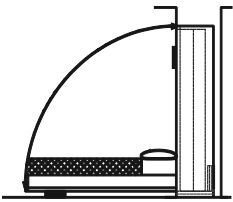

Twin, frames and mechanisms	B1@5.41	Ea	884.00	185.00	1,069.00
Double, frames and mechanisms	B1@5.41	Ea	926.00	185.00	1,111.00
Queen, frames and mechanisms	B1@5.41	Ea	967.00	185.00	1,152.00
King, frames and mechanisms	B1@5.41	Ea	1,060.00	185.00	1,245.00
Add for wood-tone melamine cabinet	—	LS	1,570.00	—	1,570.00
Add for white melamine cabinet	—	LS	1,400.00	—	1,400.00

Blueprinting (Reproduction only) Assumes original is on semi-transparent drafting paper or film. See also Architectural Illustration and Drafting. Cost per square foot reproduced except as noted. Stapled edge and binder included.

Blueline or blackline prints

1-100 SF	—	SF	—	—	.22
101-1,000 SF	—	SF	—	—	.20
1,001-2,000 SF	—	SF	—	—	.19
2,001-to 3,000 SF	—	SF	—	—	.17
3,001-4,000 SF	—	SF	—	—	.09
4,001 SF and higher	—	SF	—	—	.08
Presentation blackline (heavy paper)	—	SF	—	—	.57
Sepia	—	SF	—	—	.84
Mylar	—	SF	—	—	2.80
Xerographic prints					
Vellum	—	SF	—	—	1.12
Erasable vellum	—	SF	—	—	1.40
Mylar	—	SF	—	—	2.80
Enlargements (bond)	—	SF	—	—	.67
Reductions (bond, per sheet)	—	Ea	—	—	2.79

Building Inspection Service

	Craft@Hrs	Unit	Material	Labor	Total
Plotting prints					
Translucent bond	—	SF	—	—	1.68
Vellum	—	SF	—	—	1.95
Erasable vellum	—	SF	—	—	2.78
Mylar	—	SF	—	—	2.80
Photo prints					
Mylar	—	SF	—	—	6.27
Add for local pickup and delivery, round trip	—	LS	—	—	25.00

Building Inspection Service (Home inspection service) Inspection of all parts of building by qualified engineer or certified building inspection technician. Includes written report covering all doors and windows, electrical system, foundation, heating and cooling system, insulation, interior and exterior surface conditions, landscaping, plumbing system, roofing, and structural integrity.

Single-family residence

Base fee (up to 2,500 SF)	—	LS	—	—	352.00
Add for additional 1,000 SF or fraction	—	LS	—	—	108.00
Add for out buildings (each)	—	LS	—	—	54.10
Add for houses over 50 years old	—	LS	—	—	81.10
Add per room for houses with over 10 rooms	—	Ea	—	—	64.90
Add per room for houses with over 15 rooms	—	Ea	—	—	70.40
Add for swimming pool, spa or sauna	—	LS	—	—	214.00
Add for soil testing (expansive soil only)	—	LS	—	—	216.00
Add for water testing (coliform only)	—	LS	—	—	75.80
Add for warranty protection					
Houses to 10 rooms & 50 years old	—	LS	—	—	270.00
Houses over 50 years old	—	LS	—	—	290.00
Houses over 10 rooms	—	LS	—	—	292.00

Multi-family structures

Two family residence base fee	—	LS	—	—	488.00
Apartment or condominium base fee	—	LS	—	—	270.00
Warranty protection (base cost)	—	LS	—	—	270.00
Add for each additional unit	—	LS	—	—	54.20
Add for each family living unit					
Standard inspection	—	LS	—	—	54.10
Detailed inspection	—	LS	—	—	80.50
Add for swimming pool, spa, sauna	—	LS	—	—	81.10
Add for potable water quality testing	—	LS	—	—	244.00
Add for water quantity test, per well	—	LS	—	—	162.00
Add for soil testing (EPA toxic)	—	LS	—	—	1,620.00
Add for soil testing (lead)	—	LS	—	—	48.80
Add for lead paint testing, full analysis, per room	—	LS	—	—	43.30
Hazards testing for single and multi-family dwellings					
Urea-formaldehyde insulation testing	—	LS	—	—	189.00
Asbestos testing	—	LS	—	—	191.00
Radon gas testing	—	LS	—	—	136.00
Geotechnical site examination, typical price	—	LS	—	—	435.00

Building Paper

	Craft@Hrs	Unit	Material	Labor	Total
Building Paper See also Roofing for roof applications and Polyethylene Film. Costs include 7% coverage allowance for 2" lap and 5% waste allowance. See installation costs at the end of this section.					
Asphalt felt, 36" wide					
15 lb., ASTM F45 (432 SF roll)	—	SF	.06	—	.06
15 lb., F40 (432 SF roll)	—	SF	.05	—	.05
30 lb. (216 SF roll)	—	SF	.13	—	.13
Asphalt shake felt, 18" x 72"					
30 lb. (108 SF roll)	—	SF	.19	—	.19
Building paper, 40" wide					
Single ply, black (1,078 SF roll)	—	SF	.06	—	.06
Two ply (539 SF roll)	—	SF	.08	—	.08
Aquabar™, two layer, laminated with asphalt, Fortifiber™ products					
Class A, 36" wide, 30-50-30					
(1,000 SF roll)	—	SF	.05	—	.05
Class B, 36" wide, 30-30-30					
(500 SF roll)	—	SF	.07	—	.07
Ice and water shield, self-adhesive rubberized asphalt and poly					
225 SF roll	—	SF	1.01	—	1.01
High temperature, 225 SF roll	—	SF	1.11	—	1.11
"Jumbo Tex" gun grade sheathing paper, 40" wide, asphalt saturated					
(324 SF roll)	—	SF	.07	—	.07
"Jumbo Tex" black building paper, 36", 40" wide, asphalt saturated					
(500 SF roll)	—	SF	.10	—	.10
"Super Jumbo Tex" two-ply, 60 minute, asphalt saturated Kraft					
(162 SF roll)	—	SF	.11	—	.11
Red rosin sized sheathing (duplex sheathing) 36" wide					
(501 SF roll)	—	SF	.03	—	.03
Bruce rosin paper, floor underlay					
(500 SF roll)	—	SF	.04	—	.04
Moistop flashing paper, Fortifiber™, 12" wide x 300' long					
(300 SF roll)	—	SF	.14	—	.14
Vycor window and door flashing, self adhesive, Grace					
6" x 75' roll, 25 mil thickness	—	SF	2.14	—	2.14
Vycor deck protector, self adhesive joist flashing, Grace					
4" x 75' roll, Roll covers 66 LF of joist	—	LF	2.24	—	2.24
Plasterkraft grade D weather-resistive sheathing paper, 40" wide					
Super 60 minute (500 SF roll)	—	SF	.05	—	.05
Ten minute 2-ply (500 SF roll)	—	SF	.03	—	.03
Roof flashing paper, seals around skylights, dormers, vents, valleys and eaves, rubberized, fiberglass reinforced, self-adhesive					
GAF StormGuard™ Roll covers 200 SF	—	SF	.58	—	.58
Roof underlay, for use under shingles, granular surface					
Weatherlock® 200 SF roll	—	SF	.56	—	.56
Tri-Flex roof underlay, for use under shingles, tile, slate or metal roofing					
48" x 250', 1,000 SF roll	—	SF	.13	—	.13
Below grade vapor barrier, Fortifiber™ Moistop					
(fiberglass reinforced Kraft between 2 layers of polyethylene)					
8' x 250' roll (2,000 SF roll)	—	SF	.21	—	.21

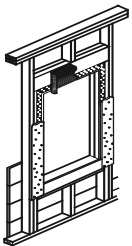

Building Permit Fees

	Craft@Hrs	Unit	Material	Labor	Total
Concrete curing papers, Fortifiber™					
Orange Label Sisalkraft (fiberglass and adhesive between 2 layers of Kraft), 4.8 lbs. per CSF 48" x 125' roll, (500 SF roll)	—	SF	.27	—	.27
Sisalkraft SK-10, economy papers, fiberglass and adhesive between 2 layers of Kraft, 4.2 lbs. per CSF 48" x 300' roll (1,200 SF roll)	—	SF	.08	—	.08
Protective paper, Fortifiber™ Seekure (fiberglass reinforcing strands and nonstaining adhesive between 2 layers of Kraft)					
8" x 300' roll, (2,400 SF)	—	SF	.10	—	.10
House wrap membrane, aka Tyvek™ HomeWrap by DuPont					
Air/moisture infiltration barrier (high-density polyethylene fibers in sheet form)					
3' x 100' rolls or					
9' x 150' rolls	—	SF	.20	—	.20
House wrap tape, 2" x 165'	—	LF	.12	—	.12
Labor to install building papers					
Felts, vapor barriers, infiltration barriers, building papers on walls					
Tack stapled, typical	BC@.002	SF	—	.08	.08
Heavy stapled, typical	BC@.003	SF	—	.11	.11
Felts, vapor barriers, infiltration barriers, building papers on ceilings and roofs					
Tack stapled, typical	BC@.004	SF	—	.15	.15
Heavy stapled, typical	BC@.006	SF	—	.23	.23
Self-adhesive, typical	BC@.006	SF	—	.23	.23
Curing papers, protective papers and vapor barriers, minimal fasteners					
	BC@.001	SF	—	.04	.04
Flashing papers, 6" to 8" wide	BC@.010	LF	—	.38	.38

Building Permit Fees Fees are set by each jurisdiction and are based on the type of construction and the square foot area. Most building departments either publish a fee schedule or offer a Web-based fee calculator. The permit fee will usually be doubled when work is started without a permit. When the valuation of the proposed construction exceeds \$1,000, plans are usually required. For most residential construction, building permit will be about 1% of the construction cost (with a \$200 minimum) based on a table of values published by the International Code Council at:

<https://www.iccsafe.org/products-and-services/i-codes/code-development-process/building-valuation-data/>

Most wood-frame residences are Group R3 and Type VB. This estimate of 1% includes the plan check fee, building, plumbing, HVAC and electrical permits, GIS mapping and issuance of a certificate of occupancy.

Permits required by planning authorities will be extra. Estimate the fee for reinspection at \$145 per hour.

Inspections outside normal business hours are about \$145 per hour with a two-hour minimum. Estimate the fee for additional plan review required by changes, additions or revisions to approved plans at \$155 per hour with a one-half hour minimum.

Minimum building permit fee	—	LS	200.00	—	200.00
Typical fee based on estimated total construction cost	—	%	1.0	—	—

Cabinets, Kitchen

Craft@Hrs Unit Material Labor Total

Cabinets, Kitchen See also Vanities. Good quality mill-made modular units with solid hardwood face frames, hardwood door frames and drawer fronts, hardwood veneer on raised door panels (front and back), glued mortise, dowel, and dado joint construction, full backs (1/8" vinyl laminated plywood), vinyl laminated cabinet interiors, vinyl laminated composition drawer bodies with nylon and metal guides. Includes self-closing hinges, door and drawer pulls, mounting hardware and adjustable shelves. See illustrations for unit types. See the price adjustments below for pricing of other units. No countertops included. See Countertops, page 96.

Kitchen cabinet costs vary widely. The prices listed in this section are for standard grade residential cabinets. Add 65% to material costs for premium grade cabinets with solid hardwood fronts and frames, mitered corners and solid wood drawer bodies with steel guides and ball bearings. Deduct 45% from material costs for economy grade cabinets, laminated plastic on particleboard.

Cabinets, Rule of Thumb Cabinet cost per running foot of cabinet installed. These figures are based on a set of mill-fabricated and assembled kitchen cabinets including a sink base cabinet, one 3-drawer base cabinet and six door base cabinets. Per linear foot of front or back edge, whichever is longer.

Base cabinets, 34-1/2" high, 24" deep	BC@.521	LF	178.00	19.60	197.60
Wall cabinets, 30" high, 12" deep	BC@.340	LF	93.00	12.80	105.80

Cabinets, Kitchen (See the note above on cabinet costs.)

One door base cabinets, 34-1/2" high, 24" deep

9" wide, tray divider	BC@.461	Ea	168.00	17.40	185.40
12" wide, 1 door, 1 drawer	BC@.461	Ea	224.00	17.40	241.40
15" wide, 1 door, 1 drawer	BC@.638	Ea	239.00	24.00	263.00
18" wide, 1 door, 1 drawer	BC@.766	Ea	252.00	28.80	280.80
21" wide, 1 door, 1 drawer	BC@.766	Ea	274.00	28.80	302.80
24" wide, 1 door, 1 drawer	BC@.911	Ea	281.00	34.30	315.30

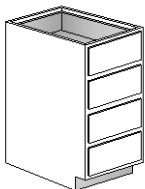

DRAWER BASE

Drawer base cabinets, 34-1/2" high, 24" deep

15" wide, 4 drawers	BC@.638	Ea	246.00	24.00	270.00
18" wide, 4 drawers	BC@.766	Ea	261.00	28.80	289.80
24" wide, 4 drawers	BC@.911	Ea	303.00	34.30	337.30

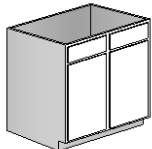

SINK BASE

Sink base cabinets, 34-1/2" high, 24" deep

24" wide, 1 door, 1 drawer front	BC@.740	Ea	239.00	27.90	266.90
30" wide, 2 doors, 2 drawer fronts	BC@.766	Ea	288.00	28.80	316.80
33" wide, 2 doors, 2 drawer fronts	BC@.766	Ea	303.00	28.80	331.80
36" wide, 2 doors, 2 drawer fronts	BC@.766	Ea	310.00	28.80	338.80
42" wide, 2 doors, 2 drawer fronts	BC@.911	Ea	342.00	34.30	376.30
48" wide, 2 doors, 2 drawer fronts	BC@.911	Ea	376.00	34.30	410.30

Two door base cabinets, 34-1/2" high, 24" deep

27" wide, 2 door, 2 drawer front	BC@1.25	Ea	370.00	47.10	417.10
30" wide, 2 doors, 2 drawer fronts	BC@1.25	Ea	391.00	47.10	438.10
33" wide, 2 doors, 2 drawer fronts	BC@1.25	Ea	409.00	47.10	456.10
36" wide, 2 doors, 2 drawer fronts	BC@1.35	Ea	431.00	50.80	481.80
42" wide, 2 doors, 2 drawer fronts	BC@1.50	Ea	448.00	56.50	504.50
48" wide, 2 doors, 2 drawer fronts	BC@1.71	Ea	498.00	64.40	562.40

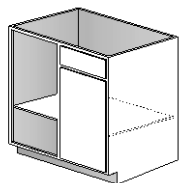

BLIND CORNER BASE

Blind corner base cabinets, 34-1/2" high

Minimum 36", maximum 39" at wall	BC@1.39	Ea	274.00	52.30	326.30
Minimum 39", maximum 42" at wall	BC@1.50	Ea	295.00	56.50	351.50
Corner base cabinet, revolving shelves 34-1/2" high x 36" wide at walls	BC@2.12	Ea	424.00	79.80	503.80

Cabinets, Kitchen

	Craft@Hrs	Unit	Material	Labor	Total
Corner sink front, 34-1/2" high 40" wide at walls	BC@2.63	Ea	239.00	99.00	338.00
Wall cabinets, adjustable shelves, 30" high, 12" deep					
9" wide, 1 door	BC@.461	Ea	151.00	17.40	168.40
12" wide or 15" wide, 1 door	BC@.461	Ea	164.00	17.40	181.40
18" wide, 1 door	BC@.638	Ea	194.00	24.00	218.00
21" wide, 1 door	BC@.638	Ea	200.00	24.00	224.00
24" wide, 1 door	BC@.766	Ea	215.00	28.80	243.80
27" wide, 2 doors	BC@.766	Ea	252.00	28.80	280.80
30" wide, 2 doors	BC@.911	Ea	252.00	34.30	286.30
33" wide, 2 doors	BC@.911	Ea	274.00	34.30	308.30
36" wide, 2 doors	BC@1.03	Ea	289.00	38.80	327.80
42" wide, 2 doors	BC@1.03	Ea	310.00	38.80	348.80
48" wide, 2 doors	BC@1.16	Ea	335.00	43.70	378.70
Above-appliance wall cabinets, 12" deep					
12" high, 30" wide, 2 doors	BC@.461	Ea	159.00	17.40	176.40
15" high, 30" wide, 2 doors	BC@.461	Ea	182.00	17.40	199.40
15" high, 33" wide, 2 doors	BC@.537	Ea	195.00	20.20	215.20
15" high, 36" wide, 2 doors	BC@.638	Ea	200.00	24.00	224.00
18" high, 18" wide, 2 doors	BC@.537	Ea	151.00	20.20	171.20
18" high, 30" wide, 2 doors	BC@.766	Ea	200.00	28.80	228.80
18" high, 36" wide, 2 doors	BC@.911	Ea	221.00	34.30	255.30
Corner wall cabinets, 30" high, 12" deep					
24" at each wall, fixed shelves	BC@1.03	Ea	274.00	38.80	312.80
24" at each wall, revolving shelves	BC@1.03	Ea	368.00	38.80	406.80
Blind corner wall cabinets, 30" high					
24" minimum, 1 door	BC@1.03	Ea	208.00	38.80	246.80
36" minimum, 1 door	BC@1.32	Ea	252.00	49.70	301.70
42" minimum, 2 doors	BC@1.20	Ea	317.00	45.20	362.20
Utility cabinets, 66" high, 12" deep, no shelves					
18" wide	BC@1.32	Ea	317.00	49.70	366.70
24" wide	BC@1.71	Ea	362.00	64.40	426.40
Utility cabinets, 66" high, 24" deep, add shelf cost below					
18" wide	BC@1.24	Ea	335.00	46.70	381.70
24" wide	BC@1.71	Ea	398.00	64.40	462.40
Add for utility cabinet revolving shelves, includes mounting hardware					
18" wide x 24" deep	BC@.360	Ea	288.00	13.60	301.60
24" wide x 24" deep	BC@.360	Ea	337.00	13.60	350.60
Add for utility cabinet plain shelves					
18" wide x 24" deep	BC@.541	Ea	97.30	20.40	117.70
24" wide x 24" deep	BC@.541	Ea	102.00	20.40	122.40
Oven cabinets, 66" high, 24" deep					
27" wide, single oven	BC@2.19	Ea	402.00	82.50	484.50
27" wide, double oven	BC@2.19	Ea	296.00	82.50	378.50

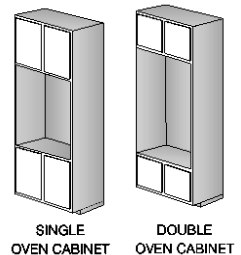
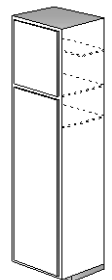
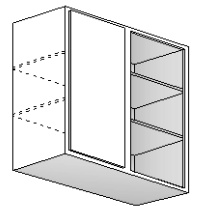
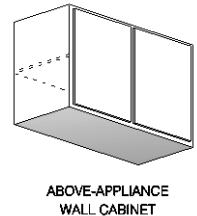
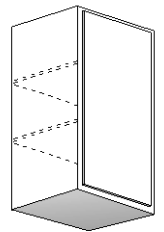
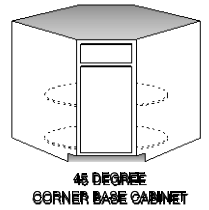

Cabinets, Kitchen

	Craft@Hrs	Unit	Material	Labor	Total
Microwave cabinet, with trim, 21" high, 20" deep, 30" wide	BC@.986	Ea	242.00	37.10	279.10
Additional labor costs for cabinets					
Tall utility, pantry, or oven cabinets	BC@2.00	Ea	—	75.30	75.30
Tall wall cabinet to counter level	BC@1.50	Ea	—	56.50	56.50
Hood cabinet over a range with vent cutout	BC@1.50	Ea	—	56.50	56.50
3/4" raised end panels applied to cabinet ends	BC@.250	Ea	—	9.42	9.42
Refrigerator end panels, cut, fit, install	BC@.500	Ea	—	18.80	18.80
Cabinet end panels, most sizes, per panel					
Refrigerator end panels	BC@.557	Ea	—	21.00	21.00
Refrigerator end panels with return	BC@1.00	Ea	—	37.70	37.70
Applied decorative end panels	BC@.334	Ea	—	12.60	12.60
Mitered island end or back panels	BC@.667	Ea	—	25.10	25.10
Dishwasher return panels	BC@.667	Ea	—	25.10	25.10
Precut filler panels installed between cabinets, per panel					
Most base or wall fillers	BC@.200	Ea	—	7.53	7.53
Most base or wall fillers with overlays	BC@.400	Ea	—	15.10	15.10
Tall filler panels over 36"	BC@.268	Ea	—	10.10	10.10
Tall filler panels over 36" with overlays	BC@.535	Ea	—	20.10	20.10
Corner filler panels	BC@.224	Ea	—	8.44	8.44
Corner fillers panels with overlays	BC@.448	Ea	—	16.90	16.90
Angled corner filler panels	BC@.268	Ea	—	10.10	10.10
Angled corner filler panels with overlays	BC@.536	Ea	—	20.20	20.20
Moldings and trim for cabinet work					
Scribe molding, per 8' length	BC@.224	Ea	—	8.44	8.44
Scribe molding, per linear foot	BC@.028	LF	—	1.05	1.05
Crown molding, per 8' length, miter cut	BC@.448	Ea	—	16.90	16.90
Crown molding, per 8' length, butt joint	BC@.180	Ea	—	6.78	6.78
Crown plate and riser, per miter cut	BC@.180	Ea	—	6.78	6.78
Crown plate and riser, per straight cut	BC@.112	Ea	—	4.22	4.22
Applied molding, per miter cut	BC@.112	Ea	—	4.22	4.22
Applied molding, per straight cut	BC@.067	Ea	—	2.52	2.52
Light rail molding, per miter cut	BC@.224	Ea	—	8.44	8.44
Light rail molding, per straight cut	BC@.067	Ea	—	2.52	2.52
Furniture toe kick, per 8' length	BC@.334	Ea	—	12.60	12.60
Furniture toe kick, per linear foot	BC@.042	LF	—	1.58	1.58
Valance, straight, per 8' length	BC@.334	Ea	—	12.60	12.60
Valance, with side returns or cap, 8' length	BC@.667	Ea	—	25.10	25.10
Mantle or hood molding, length to 8'	BC@.800	Ea	—	30.10	30.10
Corbels, plain	BC@.224	Ea	—	8.44	8.44
Corbels, on uprights	BC@.334	Ea	—	12.60	12.60
Enkeboll molding, miter cut, 8' length	BC@.667	Ea	—	25.10	25.10
Enkeboll molding, straight cut, 8' length	BC@.180	Ea	—	6.78	6.78
Posts, to 8' length	BC@.500	Ea	—	18.80	18.80
Pilasters	BC@.334	Ea	—	12.60	12.60
Cabinet feet, per cabinet	BC@.334	Ea	—	12.60	12.60
Cabinet extras					
Scribing in wood tops	BC@.133	LF	—	5.01	5.01
Job built 2 x 4 support wall to 42" high	BC@.334	LF	—	12.60	12.60
Framing for range support or sink cutout	BC@.667	Ea	—	25.10	25.10

Carpentry

Craft@Hrs Unit Material Labor Total

Carpentry See also carpentry items in other sections: Carpentry Steel Framing, Cabinets, Ceilings, Closet Door Systems, Countertops, Cupolas, Doors, Entrances, Flooring, Framing Connectors, Hardboard, Hardware, Lumber, Molding, Paneling, Shutters, Siding, Skylights, Soffits, Stairs, Thresholds, and Weatherstripping.

Carpentry Rule of Thumb Typical rough carpentry (framing) cost per square foot of floor in living area. These figures will apply on many residential jobs where joists, studs and rafters are 16" on center. Unconventional designs and complex framing plans will cost more. See detailed cost breakdowns in the next section.

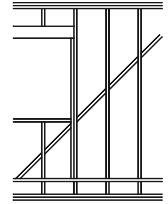

Using framing lumber at	—	MBF	1,250.00	—	1,250.00
Using 1/2" OSB sheathing at	—	MSF	1,410.00	—	1,410.00
Using 7/16" OSB sheathing at	—	MSF	1,060.00	—	1,060.00
Using 5/8" OSB sheathing at	—	MSF	1,640.00	—	1,640.00
Using 1/2" CDX sheathing at	—	MSF	1,550.00	—	1,550.00
Using 5/8" CDX sheathing at	—	MSF	2,320.00	—	2,320.00
Single story, conventional foundation	B1@.237	SF	10.97	8.08	19.05
Single story, concrete slab foundation	B1@.180	SF	7.04	6.13	13.17
First of two floors, conventional foundation	B1@.203	SF	8.51	6.92	15.43
First of two floors, concrete slab foundation	B1@.146	SF	4.58	4.97	9.55
Second floor of a two-story residence	B1@.191	SF	8.93	6.51	15.44
Add for plywood sheathing	—	%	12.0	—	—

Framing a single story residence, conventional crawl-space foundation

Sills, pier blocks, floor beams (145 BF per 1,000 SF)	B1@.018	SF	.18	.61	.79
Floor joists, doublers, blocking, bridging (1,480 BF per 1,000 SF)	B1@.028	SF	1.86	.96	2.82
Subflooring, 5/8" OSB (1,150 SF per 1,000 SF)	B1@.011	SF	1.89	.38	2.27
Layout, studs, sole plates, top plates, header and end joists, backing, blocking, bracing and framing for openings (2,250 BF per 1,000 SF)	B1@.093	SF	2.82	3.17	5.99
Ceiling joists, header and end joists, backing, blocking and bracing (1,060 BF per 1,000 SF)	B1@.045	SF	1.33	1.53	2.86
Rafters, braces, collar beams, ridge boards, 2" x 8" rafters 16" OC, (1,340 BF per 1000 SF)	B1@.032	SF	1.68	1.09	2.77
Roof sheathing, 7/16" OSB (1,150 SF per 1,000 SF)	B1@.010	SF	1.21	.34	1.55
Total framing, single story, conventional foundation	B1@.237	SF	10.97	8.08	19.05
Add for plywood sheathing	—	%	12.0	—	—

Framing a single story residence, concrete slab foundation

Layout, sole plates, anchors, studs, top plates, header and end joists, backing, blocking, bracing and framing for openings (2,250 BF per 1,000 SF)	B1@.093	SF	2.82	3.17	5.99
Ceiling joists, header and end joists, backing, blocking and bracing (1,060 BF per 1,000 SF)	B1@.045	SF	1.33	1.53	2.86
Rafters, braces, collar beams, ridge boards, 2" x 8" rafters 16" OC, (1,340 BF per 1,000 SF)	B1@.032	SF	1.68	1.09	2.77
Roof sheathing, 7/16" OSB (1,150 SF per 1,000 SF)	B1@.010	SF	1.21	.34	1.55
Total framing, single story, concrete slab foundation	B1@.180	SF	7.04	6.13	13.17
Add for plywood sheathing	—	%	8.0	—	—

Carpentry, Assemblies

	Craft@Hrs	Unit	Material	Labor	Total
Framing the first of two floors, conventional crawl-space foundation					
Sills, pier blocks, floor beams (145 BF per 1,000 SF)	B1@.018	SF	.18	.61	.79
Floor joists, doublers, blocking, bridging (1,480 BF per 1,000 SF)	B1@.028	SF	1.86	.96	2.82
Subflooring, 5/8" OSB (1,150 SF per 1,000 SF)	B1@.011	SF	1.89	.38	2.27
Layout, studs, sole plates, top plates, header and end joists, backing, blocking, bracing and framing for openings (2,250 BF per 1,000 SF)	B1@.093	SF	2.82	3.17	5.99
Rough stairway, 15 risers and landing (96 BF of dimension lumber and 128 SF of plywood per 1,000 SF)	B1@.008	SF	.43	.27	.70
Ceiling joists, header and end joists, backing, blocking and bracing (1,060 BF per 1,000 SF)	B1@.045	SF	1.33	1.53	2.86
Total framing, 1st of 2 floors, crawl-space foundation	B1@.203	SF	8.51	6.92	15.43
Add for plywood sheathing	—	%	9.0	—	—
Framing the first of two floors, concrete slab foundation					
Layout, sole plates, anchors, studs, top plates, header and end joists, backing, blocking, bracing and framing for openings (2,250 BF per 1,000 SF)	B1@.093	SF	2.82	3.17	5.99
Rough stairway, 15 risers and landing (96 BF of dimension lumber and 128 SF of plywood per 1,000 SF)	B1@.008	SF	1.33	.27	1.60
Ceiling joists, header and end joists, backing, blocking and bracing (1,060 BF per 1,000 SF)	B1@.045	SF	.43	1.53	1.96
Total framing, first of two floors, concrete foundation	B1@.146	SF	4.58	4.97	9.55
Framing the second story of a residence					
Subflooring, 5/8" OSB (1,150 SF per 1,000 SF)	B1@.011	SF	1.89	.38	2.27
Layout, studs, sole plates, top plates, header and end joists, backing, blocking, bracing and framing for openings (2,250 BF per 1,000 SF)	B1@.093	SF	2.82	3.17	5.99
Ceiling joists, header and end joists, backing, blocking and bracing (1,060 BF per 1,000 SF)	B1@.045	SF	1.33	1.53	2.86
Rafters, braces, collar beams, ridge boards, 2" x 8" rafters 16" OC (1,340 BF per 1,000 SF)	B1@.032	SF	1.68	1.09	2.77
Roof sheathing, 7/16" OSB (1,150 SF per 1,000 SF)	B1@.010	SF	1.21	.34	1.55
Total framing, second floor of a two-story residence	B1@.191	SF	8.93	6.51	15.44
Add for plywood sheathing	—	%	15.0	—	—
Floor Assemblies Costs for wood framed floor joists with subflooring and R-19 insulation. These costs include the floor joists, subflooring as described, blocking, nails and 6-1/4" thick R-1.9 fiberglass insulation between the floor joists. Figures include box or band joists and typical double joists. No beams included. Planked subflooring is based on 1.24 BF per square foot of floor. Costs shown are per square foot of area covered and include normal waste. Deduct for openings over 25 SF.					
Using framing lumber at	—	MBF	1,250.00	—	1,250.00
Using 5/8" CDX plywood subfloor at	—	MSF	2,320.00	—	2,320.00
Using 3/4" CDX plywood subfloor at	—	MSF	1,530.00	—	1,530.00
Using 7/16" OSB subfloor at	—	MSF	1,060.00	—	1,060.00
Using 5/8" OSB subfloor at	—	MSF	1,640.00	—	1,640.00
Using 3/4" OSB T&G subfloor at	—	MSF	1,900.00	—	1,900.00

Carpentry, Assemblies

	Craft@Hrs	Unit	Material	Labor	Total
Floor joists 16" OC, R-19 insulation and OSB subflooring					
7/16" OSB subfloor					
2" x 6" joists	B1@.040	SF	3.73	1.36	5.09
2" x 8" joists	B1@.041	SF	4.06	1.40	5.46
2" x 10" joists	B1@.043	SF	4.82	1.47	6.29
2" x 12" joists	B1@.044	SF	5.93	1.50	7.43
Floor joists 16" OC, R-19 insulation and OSB subflooring					
5/8" OSB subfloor					
2" x 6" joists	B1@.040	SF	4.32	1.36	5.68
2" x 8" joists	B1@.041	SF	4.65	1.40	6.05
2" x 10" joists	B1@.043	SF	5.41	1.47	6.88
2" x 12" joists	B1@.044	SF	6.52	1.50	8.02
3/4" OSB subfloor					
2" x 6" joists	B1@.042	SF	4.58	1.43	6.01
2" x 8" joists	B1@.043	SF	4.90	1.47	6.37
2" x 10" joists	B1@.045	SF	5.67	1.53	7.20
2" x 12" joists	B1@.046	SF	6.77	1.57	8.34
Floor joists 16" OC, R-19 insulation and plywood subflooring					
5/8" plywood subfloor					
2" x 6" joists	B1@.040	SF	4.19	1.36	5.55
2" x 8" joists	B1@.041	SF	4.51	1.40	5.91
2" x 10" joists	B1@.043	SF	5.28	1.47	6.75
2" x 12" joists	B1@.044	SF	6.38	1.50	7.88
3/4" plywood subfloor					
2" x 6" joists	B1@.042	SF	4.20	1.43	5.63
2" x 8" joists	B1@.043	SF	4.53	1.47	6.00
2" x 10" joists	B1@.045	SF	5.29	1.53	6.82
2" x 12" joists	B1@.046	SF	6.40	1.57	7.97
For different type insulation					
Fiberglass batts					
10" thick R-30, add	—	SF	.27	—	.27
12" thick R-38, add	—	SF	.72	—	.72

Wall Assemblies Costs for wood framed stud walls with wall finish treatment on both sides. These costs include wall studs at 16" center to center, double top plates, single bottom plates, fire blocking, nails and wall finish treatment as described. No headers or posts included. All lumber is Std & Btr. 2" x 4" walls have 1.12 BF per SF of wall and 2" x 6" walls have 1.68 BF per SF of wall. Costs shown are per SF or LF of wall measured on one face and include normal waste.

Using 2 x 4 lumber at	—	MBF	1,240.00	—	1,240.00
Using 2 x 6 lumber at	—	MBF	1,260.00	—	1,260.00
Using 1/2" gypsum wallboard at	—	SF	.45	—	.45
Using 5/8" gypsum wallboard at	—	SF	.49	—	.49

Interior wall assemblies

2" x 4" stud walls with 1/2" gypsum drywall both sides, ready for painting					
Cost per square foot of wall	B1@.064	SF	1.94	2.18	4.12
Cost per running foot, for 8' high walls	B1@.512	LF	15.50	17.50	33.00
2" x 4" stud walls with 1/2" gypsum drywall one side, ready for painting					
Cost per square foot of wall	B1@.046	SF	1.49	1.57	3.06
Cost per running foot, for 8' high walls	B1@.368	LF	11.90	12.60	24.50
2" x 4" stud walls with 5/8" gypsum fire rated drywall both sides, ready for painting					
Cost per square foot of wall	B1@.068	SF	2.03	2.32	4.35
Cost per running foot, for 8' high walls	B1@.544	LF	16.20	18.60	34.80

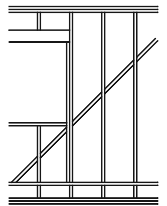

Carpentry, Assemblies

	Craft@Hrs	Unit	Material	Labor	Total
2" x 4" stud walls with 5/8" gypsum fire rated drywall one side, ready for painting					
Cost per square foot of wall	B1@.048	SF	1.53	1.64	3.17
Cost per running foot, for 8' high walls	B1@.384	LF	12.30	13.10	25.40
2" x 6" stud walls with 1/2" gypsum drywall both sides, ready for painting					
Cost per square foot of wall	B1@.072	SF	2.51	2.46	4.97
Cost per running foot, for 8' high walls	B1@.576	LF	20.10	19.60	39.70
2" x 6" stud walls with 1/2" gypsum drywall one side, ready for painting					
Cost per square foot of wall	B1@.054	SF	2.06	1.84	3.90
Cost per running foot, for 8' high walls	B1@.432	LF	16.50	14.70	31.20
2" x 6" stud walls with 5/8" gypsum fire rated drywall both sides, ready for painting					
Cost per square foot of wall	B1@.076	SF	2.60	2.59	5.19
Cost per running foot, for 8' high walls	B1@.608	LF	20.80	20.70	41.50
2" x 6" stud walls with 5/8" gypsum fire rated drywall one side, ready for painting					
Cost per square foot of wall	B1@.056	SF	2.11	1.91	4.02
Cost per running foot, for 8' high walls	B1@.448	LF	16.90	15.30	32.20

Exterior wall assemblies

2" x 4" stud walls with drywall interior, wood siding exterior, 1/2" gypsum drywall inside face ready for painting, over 3-1/2" R-13 insulation with 5/8" thick rough sawn T-1-11 exterior grade plywood siding on the outside face.					
Using 5/8" rough sawn T-1-11 siding at	—	MSF	2,320.00	—	2,320.00
Cost per square foot of wall	B1@.068	SF	4.36	2.32	6.68
Cost per running foot, for 8' high walls	B1@.544	LF	34.90	18.60	53.50
2" x 6" stud walls with drywall interior, wood siding exterior, same construction as above, except with 6-1/4" R-19 insulation					
Cost per square foot of wall	B1@.077	SF	5.16	2.63	7.79
Cost per running foot, for 8' high walls	B1@.616	LF	41.30	21.00	62.30
2" x 4" stud walls with drywall interior, 1/2" gypsum drywall on inside face ready for painting, over 3-1/2" R-11 insulation with 1" x 6" southern yellow pine drop siding, D grade, 1.19 BF per SF at 5-1/4" exposure on the outside face.					
Using D grade yellow pine drop siding at	—	MSF	3,370.00	—	3,370.00
Cost per square foot of wall	B1@.074	SF	5.41	2.52	7.93
Cost per running foot, for 8' high wall	B1@.592	LF	43.30	20.20	63.50
2" x 6" stud walls with drywall interior, 1" x 6" drop siding exterior, same construction as above, except with 6-1/4" R-19 insulation					
Cost per square foot of wall	B1@.083	SF	6.21	2.83	9.04
Cost per running foot, for 8' high wall	B1@.664	LF	49.70	22.60	72.30
2" x 4" stud walls with drywall interior, stucco exterior, 1/2" gypsum drywall on inside face ready for painting, over 3-1/2" R-11 insulation and a three-coat exterior plaster (stucco) finish with integral color on the outside face					
Cost per square foot of wall	B1@.050	SF	5.42	1.71	7.13
Cost per running foot, for 8' high wall	B1@.400	LF	43.40	13.60	57.00
2" x 6" stud walls with drywall interior, stucco exterior, same construction as above, except with 6-1/4" R-19 insulation					
Cost per square foot of wall	B1@.059	SF	6.23	2.01	8.24
Cost per running foot, for 8' high wall	B1@.472	LF	49.80	16.10	65.90
Add for different type gypsum board					
1/2" or 5/8" moisture resistant greenboard					
Cost per SF, greenboard per side, add	—	SF	.15	—	.15
1/2" or 5/8" moisture resistant greenboard					
Cost per running foot per side 8' high	—	LF	1.19	—	1.19
5/8" thick fire rated type X gypsum drywall					
Cost per SF, per side, add	—	SF	.09	—	.09
5/8" thick fire rated type X gypsum drywall					
Cost per running foot per side 8' high	—	LF	.73	—	.73

Carpentry, Assemblies

Craft@Hrs Unit Material Labor Total

Ceiling Assemblies Costs for wood framed ceiling joists with ceiling finish and fiberglass insulation, based on performing the work at the construction site. These costs include the ceiling joists, ceiling finish as described, blocking, nails and 3-1/2" thick R-13 fiberglass insulation batts between the ceiling joists. Figures in parentheses indicate board feet per square foot of ceiling framing including end joists and typical header joists. No beams included. Ceiling joists and blocking are based on standard and better grade lumber. Costs shown are per square foot of area covered and include normal waste. Deduct for openings over 25 SF.

Ceiling joists with 5/8" regular gypsum drywall taped and sanded smooth finish, ready for paint

Using 2" x 4" at	—	MBF	1,240.00	—	1,240.00
Using 2" x 6" at	—	MBF	1,260.00	—	1,260.00
Using 2" x 8" at	—	MBF	1,110.00	—	1,110.00

2" x 4" ceiling joists at 16" on center (.59 BF per SF), with insulation and 1/2" gypsum drywall	B1@.053	SF	2.18	1.81	3.99
--	---------	----	------	------	------

2" x 6" ceiling joists at 16" on center (.88 BF per SF), with insulation and 1/2" gypsum drywall	B1@.055	SF	2.77	1.88	4.65
--	---------	----	------	------	------

2" x 8" ceiling joists at 16" on center (1.17 BF per SF), with insulation and 1/2" gypsum drywall	B1@.057	SF	3.06	1.94	5.00
---	---------	----	------	------	------

For spray applied plaster finish (sometimes called "popcorn" or "cottage cheese" texture)

Add for ceiling texture	DT@.011	SF	.02	.41	.43
-------------------------	---------	----	-----	-----	-----

For different type gypsum drywall with taped and sanded smooth finish, ready for paint

5/8" moisture resistant greenboard, add	—	SF	.11	—	.11
---	---	----	-----	---	-----

5/8" ultralight, add	—	SF	.02	—	.02
----------------------	---	----	-----	---	-----

5/8" fire rated "C", add	—	SF	.09	—	.09
--------------------------	---	----	-----	---	-----

For different ceiling joist center to center dimensions

2" x 4" ceiling joists

12" on center, add	B1@.004	SF	.23	.14	.37
--------------------	---------	----	-----	-----	-----

20" on center, deduct	—	SF	-.14	-.07	-.21
-----------------------	---	----	------	------	------

24" on center, deduct	—	SF	-.21	-.10	-.31
-----------------------	---	----	------	------	------

2" x 6" ceiling joists

12" on center, add	B1@.006	SF	.34	.20	.54
--------------------	---------	----	-----	-----	-----

20" on center, deduct	—	SF	-.20	-.07	-.27
-----------------------	---	----	------	------	------

24" on center, deduct	—	SF	-.31	-.10	-.41
-----------------------	---	----	------	------	------

2" x 8" ceiling joists

12" on center, add	B1@.006	SF	.40	.20	.60
--------------------	---------	----	-----	-----	-----

20" on center, deduct	—	SF	-.23	-.07	-.30
-----------------------	---	----	------	------	------

24" on center, deduct	—	SF	-.37	-.10	-.47
-----------------------	---	----	------	------	------

For different type insulation

Fiberglass batts

6-1/4" thick R-19, add	—	SF	.19	—	.19
------------------------	---	----	-----	---	-----

10" thick R-30, add	—	SF	.53	—	.53
---------------------	---	----	-----	---	-----

Blown-in fiberglass, subcontract

8" thick R-19, add	—	SF	—	—	.59
--------------------	---	----	---	---	-----

Roofing Assemblies Costs for wood framed roof assemblies with roof finish material as shown based on performing the work at the construction site. Costs shown include all material and labor required above the top plate or ledger on the supporting walls. These costs assume the supporting wall structure is in-place and suitable for the assembly described.

Carpentry, Assemblies

Craft@Hrs Unit Material Labor Total

Flat roof assembly Based on using 2" x 12" joists Std & Btr grade at 16" on center including blocking, ripped strips and normal waste. The roof surface is built-up 3 ply asphalt consisting of 2 plies of 15 lb. felt hot mopped with a 90 lb. mineral-coated cap sheet.

Using 2" x 12" joists at	—	MBF	1,350.00	—	1,350.00
Using 2" x 8" joists at	—	MBF	1,110.00	—	1,110.00
Using 1/2" CDX plywood at	—	MSF	1,550.00	—	1,550.00
Using 7/16" OSB at	—	MSF	1,060.00	—	1,060.00

Flat roof assembly as described above

Framing, with plywood sheathing	B1@5.00	Sq	495.00	171.00	666.00
Framing, with OSB sheathing	B1@5.00	Sq	443.00	171.00	614.00
Built-up roofing, 3-ply and gravel	R1@2.15	Sq	107.00	77.90	184.90

Conventionally framed roof assemblies Based on straight gable type roof (no hips, valleys, or dormers) with 6" in 12" rise or less. Cost per 100 square feet of plan area under the roof, not actual roof surface area. Framing includes 2" x 8" common rafters Std & Btr grade at 24" on center. Cost includes blocking, ridge and normal bracing. Roof sheathing is either 7/16" OSB (oriented strand board) or 1/2" CDX plywood.

Conventionally framed roof assembly. Select roof finish from below

Framing, with plywood sheathing	B1@4.10	Sq	166.00	140.00	306.00
Framing, with OSB sheathing	B1@4.10	Sq	130.00	140.00	270.00
Add for built-up 3-ply finish roofing	R1@1.25	Sq	104.00	45.30	149.30
Add for composition shingle (Class C) roofing	R1@1.83	Sq	416.00	66.30	482.30
Add for asphalt shingle (Class A) roofing	R1@1.83	Sq	171.00	66.30	237.30
Framing, with no sheathing	B1@2.80	Sq	128.00	95.50	223.50
Add for 26 gauge steel roofing	R1@2.70	Sq	203.00	97.80	300.80

Add for gable studs

2" x 4" spaced 16" OC (.54 BF per SF)	B1@.023	SF	.67	.78	1.45
---------------------------------------	---------	----	-----	-----	------

Add for purlins (purling), Std & Btr, installed below roof rafters. Figures in parentheses indicate board feet per LF including 5% waste

Using 2" x 8" joists at	—	MBF	1,110.00	—	1,110.00
2" x 8" (1.40 BF per LF)	B1@.023	LF	1.55	.78	2.33

Piecework, Rough Carpentry Rough carpentry on residential tracts is usually done by framing subcontractors who bid at piecework rates (such as per square foot of floor). The figures below list typical piecework rates for repetitive framing work and assume all materials are supplied to the framing subcontractor. No figures appear in the Craft@Hrs column because the work is done for a fixed price per square foot and the labor productivity can be expected to vary widely.

Layout and plating Piecework rates

Lay out wall plates according to the plans (snap chalk lines for wall plates, mark location for studs, windows, doors and framing details), cut top and bottom plates and install bottom plates. Costs per square foot of floor (excluding garage).

Custom or more complex jobs	—	SF	—	.27	.27
Larger job, longer runs	—	SF	—	.18	.18

Wall framing Piecework rates

Measure, cut, fit, assemble, and tip up walls, including studs, plates, cripples, let-in braces, trimmers and blocking. Costs per square foot of floor.

Complex job, radius walls, rake walls	—	SF	—	.75	.75
Larger job, 8' high walls, fewer partitions	—	SF	—	.27	.27

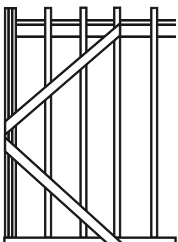

Carpentry, Piecework

Craft@Hrs Unit Material Labor Total

Plumb and align framed walls Piecework rates

Force walls into alignment. Adjust walls to vertical and install temporary wood braces as needed. Bracing plates includes shooting powder driven fasteners through wall plates. Based on accuracy to 3/16". Includes re-checking plumb and alignment when framing is done. Costs per square foot of floor.

Small or complex job, brace walls and plates	—	SF	—	.24	.24
Larger job, fewer braces, walls only	—	SF	—	.14	.14
Sheathed walls, squared before lifting	—	SF	—	.08	.08

Floor joists or ceiling joists Piecework rates

Lay out, cut and install floor or ceiling joists, including rim joists, doubled joists, straps, joist hangers, blocking at 8' OC and ceiling backing for drywall. Based on larger jobs with simple joist layouts set 16" OC and pre-cut blocking supplied by the general contractor. Add the cost of floor beams, if required. Costs per square foot of horizontal joist area. More complex jobs with shorter runs may cost 50% more.

2" x 8" ceiling or floor joists	—	SF	—	.21	.21
2" x 10" ceiling or floor joists	—	SF	—	.24	.24
2" x 12" ceiling or floor joists	—	SF	—	.26	.26
2" x 14" ceiling or floor joists	—	SF	—	.30	.30
Add for 12" OC spacing	—	SF	—	.09	.09
Deduct for 20" OC spacing	—	SF	—	-.03	-.03
Deduct for 24" OC spacing	—	SF	—	-.06	-.06

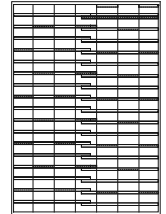

Floor sheathing Piecework rates

Lay out, cut, fit and install 5/8" or 3/4" tongue and groove plywood floor sheathing, including blocking as required. Based on nailing done with a pneumatic nailer and nails supplied by the general contractor. Costs per square foot of sheathing installed

Smaller, cut-up job	—	SF	—	.24	.24
Larger job, longer runs	—	SF	—	.18	.18
Add for 1-1/8" sheathing	—	SF	—	.08	.08

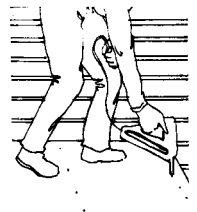

Stair framing Piecework rates

Lay out, cut, fit and install straight, "U"- or "L"-shaped 30" to 36" wide stairs made from plywood and 2" x 12" stringers set 16" OC. These costs include blocking in the adjacent stud wall and a 1" skirt board. Costs per 7-1/2" riser. Framing more complex stairs may cost up to \$500 per flight.

Small job, short runs	—	Ea	—	17.70	17.70
Larger job, longer runs	—	Ea	—	13.30	13.30
Add per 3' x 3' landing, including supports	—	Ea	—	45.50	45.50
Add for larger landings, including supports	—	Ea	—	113.00	113.00

Shear panels Piecework rates

Lay out, cut, fit and install structural 3/8" or 1/2" OSB or plywood wall panels. These figures assume shear studs were set correctly by others and that panel nails are driven at 4" OC with a pneumatic nailer. Not including hold-down straps, posts, shear blocking or extra studs. Costs per 4' x 9' panel installed.

Small job, many openings, 2nd floor	—	Ea	—	12.20	12.20
Larger job, few openings, 1st floor	—	Ea	—	7.52	7.52

Roof trusses Piecework rates

Setting and nailing engineered gable and hip roof trusses 24" OC on prepared wall plates. These figures assume that lifting equipment is provided by the general contractor and that the truss supplier provides a fill package, spreader blocks for each plate and the ridge and jack rafters (if required). Includes installation of ceiling backing where required and catwalks at the bottom chord. Costs per square foot of plan area under the truss.

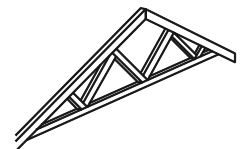

Small job assumes multiple California fill between roof surfaces and understacking

Small job, rake fill above a partition wall	—	SF	—	.66	.66
Larger job, little or no fill or understacking	—	SF	—	.37	.37

Carpentry, Detailed Breakdown

Craft@Hrs Unit Material Labor Total

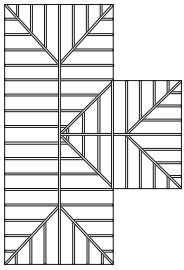

Conventional roof framing Piecework rates

Calculate lengths, lay out, cut and install 2" x 10" or 2" x 12" common, hip, valley and jack rafters on parallel and horizontal plates. Costs per square foot of plan area under the roof.

Small job, cut-up roof, few common rafters

Rafters 12" OC	—	SF	—	1.36	1.36
Rafters 16" OC	—	SF	—	1.15	1.15
Rafters 20" OC	—	SF	—	.90	.90
Rafters 24" OC	—	SF	—	.66	.66

Larger job, longer runs, nearly all common rafters

Rafters 12" OC	—	SF	—	.65	.65
Rafters 16" OC	—	SF	—	.59	.59
Rafters 20" OC	—	SF	—	.46	.46
Rafters 24" OC	—	SF	—	.38	.38
Add for slope over 6 in 12	—	SF	—	.22	.22
Deduct for 2" x 6" or 2" x 8" rafters	—	SF	—	-.08	-.08

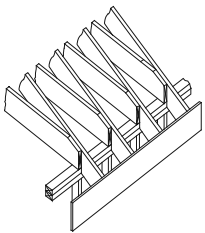

Fascia Piecework rates

Applied to rafter tails and as a barge rafter on gable ends. Includes trimming the rafter tails to the correct length and installing outlookers at gable ends. Costs per linear foot of 2" x 8" fascia installed.

Small job, short runs, with molding	—	LF	—	2.93	2.93
Larger job, longer runs	—	LF	—	1.68	1.68

Roof sheathing Piecework rates

Lay out, cut, fit and install 1/2" or 5/8" OSB or plywood roof sheathing, including blocking and 1" x 8" starter board on overhangs as required. Based on nailing done with a pneumatic nailer and nails supplied by the general contractor. Costs per square foot of sheathing installed.

Smaller, cut-up hip and valley job	—	SF	—	.25	.25
Larger job, longer runs	—	SF	—	.19	.19
Add for slope over 6 in 12	—	SF	—	.12	.12

Carpentry Cost, Detailed Breakdown This section is arranged in the order of construction. Material costs shown here can be adjusted to reflect your actual lumber cost: divide your actual lumber cost (per MBF) by the cost listed (per MBF). Then multiply the cost in the material column by this adjustment factor. No waste included

Lally columns (Residential adjustable basement column) 7' 9" to 8' 1", steel tube

Column installation, to 12' high	B1@.458	Ea	175.00	15.60	190.60
----------------------------------	---------	----	--------	-------	--------

Precast pier blocks Posts set on precast concrete pier block, including pier block with anchor placed on existing grade, temporary reusable 1" x 6" bracing (8 LF) and stakes (2). Cost is for each post set.

Add for excavation if required

Heights to 8', cost of post not included	BL@.166	Ea	7.93	5.07	13.00
--	---------	----	------	------	-------

Pier pads 2" x 6", treated, #2 & Btr

Using #2 & Btr treated lumber at	—	MBF	1,900.00	—	1,900.00
1.10 BF per LF	B1@.034	LF	2.09	1.16	1.16

Posts 4" x 4", material costs include 10% waste (1.47 BF per LF). See also Lally columns above and Posts in the Lumber section

Fir, rough Std & Btr, K.D.	—	MBF	1,570.00	—	1,570.00
Fir, rough Std & Btr, K.D. 4" x 4"	—	LF	2.31	—	2.31
Red cedar, rough green constr.	—	MBF	4,620.00	—	4,620.00
Red cedar, rough green constr.	—	LF	6.79	—	6.79
Redwood, S4S construction heart	—	MBF	3,330.00	—	3,330.00

Carpentry, Detailed Breakdown

	Craft@Hrs	Unit	Material	Labor	Total
Redwood, S4S construction heart	—	LF	4.89	—	4.89
Southern yellow pine #2, pressure treated	—	MBF	1,940.00	—	1,940.00
Southern yellow pine #2, pressure treated	—	LF	2.86	—	2.86

Girders Standard and better lumber, first floor work. Figures in parentheses show board feet per linear foot of girder, including 7% waste

4" x 6", per MBF	—	MBF	1,530.00	—	1,530.00
4" x 8", 10", 12", per MBF	—	MBF	1,660.00	—	1,660.00
6" x 6", per MBF	—	MBF	2,220.00	—	2,220.00
6" x 8", 10", 12", 8" x 8", per MBF	—	MBF	2,220.00	—	2,220.00
4" x 6" (2.15 BF per LF)	B1@.034	LF	3.29	1.16	4.45
4" x 8" (2.85 BF per LF)	B1@.045	LF	4.73	1.53	6.26
4" x 10" (3.58 BF per LF)	B1@.057	LF	5.95	1.94	7.89
4" x 12" (4.28 BF per LF)	B1@.067	LF	7.11	2.29	9.40
6" x 6" (3.21 BF per LF)	B1@.051	LF	7.14	1.74	8.88
6" x 8" (4.28 BF per LF)	B1@.067	LF	9.52	2.29	11.81
6" x 10" (5.35 BF per LF)	B1@.083	LF	11.90	2.83	14.73
6" x 12" (6.42 BF per LF)	B1@.098	LF	14.30	3.34	17.64
8" x 8" (5.71 BF per LF)	B1@.088	LF	12.70	3.00	15.70

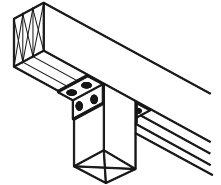

Sill plates (At foundation) SYP #2 pressure treated lumber, drilled and installed with foundation bolts at 48" OC, no bolts, nuts or washers included. See also plates in this section. Figures in parentheses indicate board feet per LF of foundation, including 5% waste and wolmanized treatment.

Sill plates, per MBF	—	MBF	1,440.00	—	1,440.00
2" x 3" (.53 BF per LF)	B1@.020	LF	.64	.68	1.32
2" x 4" (.70 BF per LF)	B1@.023	LF	1.13	.78	1.91
2" x 6" (1.05 BF per LF)	B1@.024	LF	1.38	.82	2.20
2" x 8" (1.40 BF per LF)	B1@.031	LF	1.95	1.06	3.01

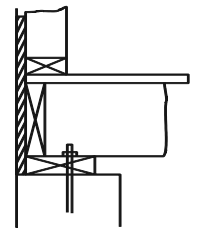

Floor joists Per SF of area covered. Figures in parentheses indicate board feet per square foot of floor including box or band joist, typical double joists, and 6% waste. No beams, blocking or bridging included. Deduct for openings over 25 SF. Costs shown are based on a job with 1,000 SF of area covered. For scheduling purposes, estimate that a two-man crew can complete 750 SF of area per 8-hour day for 12" center to center framing; 925 SF for 16" OC; 1,100 SF for 20" OC; or 1,250 SF for 24" OC.

2" x 6" Std & Btr

2" x 6" floor joists, per MBF	—	MBF	1,260.00	—	1,260.00
12" centers (1.28 BF per SF)	B1@.021	SF	1.61	.72	2.33
16" centers (1.02 BF per SF)	B1@.017	SF	1.28	.58	1.86
20" centers (.88 BF per SF)	B1@.014	SF	1.11	.48	1.59
24" centers (.73 BF per SF)	B1@.012	SF	.92	.41	1.33

2" x 8" Std & Btr

2" x 8" floor joists, per MBF	—	MBF	1,110.00	—	1,110.00
12" centers (1.71 BF per SF)	B1@.023	SF	1.89	.78	2.67
16" centers (1.36 BF per SF)	B1@.018	SF	1.50	.61	2.11
20" centers (1.17 BF per SF)	B1@.015	SF	1.29	.51	1.80
24" centers (1.03 BF per SF)	B1@.013	SF	1.14	.44	1.58

2" x 10" Std & Btr

2" x 10" floor joists, per MBF	—	MBF	1,180.00	—	1,180.00
12" centers (2.14 BF per SF)	B1@.025	SF	2.53	.85	3.38
16" centers (1.71 BF per SF)	B1@.020	SF	2.03	.68	2.71
20" centers (1.48 BF per SF)	B1@.016	SF	1.75	.55	2.30
24" centers (1.30 BF per SF)	B1@.014	SF	1.54	.48	2.02

Carpentry, Detailed Breakdown

	Craft@Hrs	Unit	Material	Labor	Total
2" x 12" Std & Btr					
2" x 12" floor joists, per MBF	—	MBF	1,350.00	—	1,350.00
12" centers (2.56 BF per SF)	B1@.026	SF	3.26	.89	4.15
16" centers (2.05 BF per SF)	B1@.021	SF	2.77	.72	3.49
20" centers (1.77 BF per SF)	B1@.017	SF	2.40	.58	2.98
24" centers (1.56 BF per SF)	B1@.015	SF	2.11	.51	2.62

Floor joist wood, TJI truss type Suitable for residential use, 50 PSF floor load design. Costs shown are per square foot (SF) of floor area, based on joists at 16" OC, for a job with 1,000 SF of floor area. Figure 1.22 SF of floor area for each LF of joist. Add the cost of beams, supports and blocking. For scheduling purposes, estimate that a two-man crew can install 900 to 950 SF of joists in an 8-hour day.

9-1/2" TJI/15	B1@.017	SF	3.27	.58	3.85
11-7/8" TJI/15	B1@.017	SF	3.92	.58	4.50
14" TJI/35	B1@.018	SF	5.72	.61	6.33
16" TJI/35	B1@.018	SF	6.23	.61	6.84

Bridging or blocking Installed between 2" x 6" thru 2" x 12" joists. Costs shown are per each set of cross bridges or per each block for solid bridging, and include normal waste. The spacing between the bridging or blocking, sometimes called a "bay," depends on job requirements. Labor costs assume bridging is cut to size on site.

1" x 4" cross					
Joist bridging, per MBF	—	MBF	2,210.00	—	2,210.00
Joists on 12" centers	B1@.034	Ea	1.10	1.16	2.26
Joists on 16" centers	B1@.034	Ea	1.51	1.16	2.67
Joists on 20" centers	B1@.034	Ea	1.92	1.16	3.08
Joists on 24" centers	B1@.034	Ea	2.32	1.16	3.48

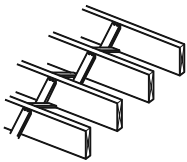

2" x 6" solid, Std & Btr					
2" x 6" blocking, per MBF	—	MBF	1,260.00	—	1,260.00
Joists on 12" centers	B1@.042	Ea	1.38	1.43	2.81
Joists on 16" centers	B1@.042	Ea	1.84	1.43	3.27
Joists on 20" centers	B1@.042	Ea	2.31	1.43	3.74
Joists on 24" centers	B1@.042	Ea	2.77	1.43	4.20

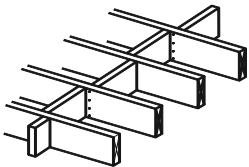

2" x 8" solid, Std & Btr					
2" x 8" blocking, per MBF	—	MBF	1,110.00	—	1,110.00
Joists on 12" centers	B1@.042	Ea	1.62	1.43	3.05
Joists on 16" centers	B1@.042	Ea	2.16	1.43	3.59
Joists on 20" centers	B1@.042	Ea	2.70	1.43	4.13
Joists on 24" centers	B1@.042	Ea	3.24	1.43	4.67

2" x 10" solid, Std & Btr					
2" x 10" blocking, per MBF	—	MBF	1,180.00	—	1,180.00
Joists on 12" centers	B1@.057	Ea	2.17	1.94	4.11
Joists on 16" centers	B1@.057	Ea	2.89	1.94	4.83
Joists on 20" centers	B1@.057	Ea	3.62	1.94	5.56
Joists on 24" centers	B1@.057	Ea	4.34	1.94	6.28

Carpentry, Detailed Breakdown

	Craft@Hrs	Unit	Material	Labor	Total
2" x 12" solid, Std & Btr					
2" x 12" blocking, per MBF	—	MBF	1,350.00	—	1,350.00
Joists on 12" centers	B1@.057	Ea	2.98	1.94	4.92
Joists on 16" centers	B1@.057	Ea	3.97	1.94	5.91
Joists on 20" centers	B1@.057	Ea	4.96	1.94	6.90
Joists on 24" centers	B1@.057	Ea	5.95	1.94	7.89
Steel, no nail type, cross Snap-on joist bridging	B1@.020	Ea	2.30	.68	2.98

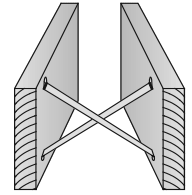

Subflooring

Board sheathing, 1" x 6" #3 & Btr (1.18 BF per SF)

Board sheathing, per MBF	—	MBF	3,750.00	—	3,750.00
With 12% shrinkage, 5% waste & nails	B1@.020	SF	4.43	.68	5.11
Add for diagonal patterns	B1@.001	SF	.44	.03	.47

Plywood sheathing, CD standard exterior grade. Material costs shown include 5% for waste & fasteners

3/8"	B1@.011	SF	.93	.38	1.31
1/2"	B1@.012	SF	1.63	.41	2.04
5/8"	B1@.012	SF	1.58	.41	1.99
3/4"	B1@.013	SF	1.60	.44	2.04

OSB sheathing, Material costs shown include 5% for waste & fasteners

3/8"	B1@.011	SF	1.50	.38	1.88
7/16"	B1@.011	SF	1.11	.38	1.49
1/2"	B1@.012	SF	1.48	.41	1.89
5/8"	B1@.012	SF	1.72	.41	2.13
3/4"	B1@.014	SF	1.99	.48	2.47
7/8"	B1@.014	SF	3.93	.48	4.41
1"	B1@.015	SF	5.71	.51	6.22

Engineered floating subfloor, 2' x 2' panels, trade name DRICore, resilient engineered wood core with a water-resistant polyethylene membrane on the underside. www.dricore.com

Per SF costs including 10% for waste	B1@.020	SF	2.10	.68	2.78
--------------------------------------	---------	----	------	-----	------

Plates (Wall plates) Std & Btr, untreated. For pressure treated plates, see also Sill Plates in this section.

Figures in parentheses indicate board feet per LF. Costs shown include 10% for waste and nails

2" x 3" wall plates, per MBF	—	MBF	1,390.00	—	1,390.00
2" x 4" wall plates, per MBF	—	MBF	1,240.00	—	1,240.00
2" x 6" wall plates, per MBF	—	MBF	1,260.00	—	1,260.00
2" x 8" wall plates, per MBF	—	MBF	1,110.00	—	1,110.00
2" x 3" (.55 BF per LF)	B1@.010	LF	.84	.34	1.18
2" x 4" (.73 BF per LF)	B1@.012	LF	.99	.41	1.40
2" x 6" (1.10 BF per LF)	B1@.018	LF	1.52	.61	2.13
2" x 8" (1.40 BF per LF)	B1@.020	LF	1.70	.68	2.38

Studding Per square foot of wall area. Do not subtract for openings less than 16' wide. Figures in parentheses indicate typical board feet per SF of wall area, measured on one side, and include normal waste. Add for each corner and partition from below. Costs include studding, nails. Add for plates from the section above and also, door and window opening framing, backing, let-in bracing, fire blocking, and sheathing for shear walls from the sections that follow. Labor includes layout, plumb and align.

2" x 3", Std & Btr					
2" x 3" studs, 16" centers, per MBF	—	MBF	1,390.00	—	1,390.00
12" centers (.55 BF per SF)	B1@.024	SF	.76	.82	1.58

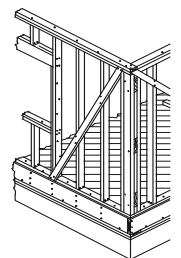

Carpentry, Detailed Breakdown

	Craft@Hrs	Unit	Material	Labor	Total
16" centers (.41 BF per SF)	B1@.018	SF	.57	.61	1.18
20" centers (.33 BF per SF)	B1@.015	SF	.46	.51	.97
24" centers (.28 BF per SF)	B1@.012	SF	.39	.41	.80
Add for each corner or partition	B1@.083	Ea	18.00	2.83	20.83
2" x 4", Std & Btr					
2" x 4" studs, 16" centers, per MBF	—	MBF	1,240.00	—	1,240.00
12" centers (.73 BF per SF)	B1@.031	SF	.90	1.06	1.96
16" centers (.54 BF per SF)	B1@.023	SF	.67	.78	1.45
20" centers (.45 BF per SF)	B1@.020	SF	.56	.68	1.24
24" centers (.37 BF per SF)	B1@.016	SF	.46	.55	1.01
Add for each corner or partition	B1@.083	Ea	21.00	2.83	23.83
2" x 6", Std & Btr					
2" x 6" studs, 24" centers, per MBF	—	MBF	1,260.00	—	1,260.00
12" centers (1.10 BF per SF)	B1@.044	SF	1.38	1.50	2.88
16" centers (.83 BF per SF)	B1@.033	SF	1.04	1.13	2.17
20" centers (.67 BF per SF)	B1@.027	SF	.84	.92	1.76
24" centers (.55 BF per SF)	B1@.022	SF	.69	.75	1.44
Add for each corner or partition	B1@.083	Ea	30.00	2.83	32.83
4" x 4", Std & Btr					
Installed in wall framing, with 10% waste	B1@.064	LF	2.30	2.18	4.48

Door opening framing In wall studs, based on walls 8' in height. Costs shown are per each door opening and include header of appropriate size, double vertical studs each side of the opening less than 8' wide (triple vertical studs each side of openings 8' wide or wider), cripples, blocking, nails and normal waste. Width shown is size of finished opening. Figures in parentheses indicate header size

2" x 4" wall studs, Std & Btr, opening size as shown					
2" x 4" wall studs, per MBF	—	MBF	1,240.00	—	1,240.00
4" x 4" and 4" x 6" headers, per MBF	—	MBF	1,570.00	—	1,570.00
4" x 8", 10", 12" and 14" headers, per MBF	—	MBF	1,660.00	—	1,660.00
To 3' wide (4" x 4" header)	B1@.830	Ea	37.20	28.30	65.50
Over 3' to 4' wide (4" x 6" header)	B1@1.11	Ea	45.30	37.90	83.20
Over 4' to 5' wide (4" x 6" header)	B1@1.39	Ea	49.70	47.40	97.10
Over 5' to 6' wide (4" x 8" header)	B1@1.66	Ea	61.20	56.60	117.80
Over 6' to 8' wide (4" x 10" header)	B1@1.94	Ea	95.50	66.20	161.70
Over 8' to 10' wide (4" x 12" header)	B1@1.94	Ea	120.00	66.20	186.20
Over 10' to 12' wide (4" x 14" header)	B1@2.22	Ea	147.00	75.70	222.70
Add per foot of height for 4" walls over 8' in height	—	LF	4.94	—	4.94
2" x 6" wall studs, Std & Btr, opening size as shown					
2" x 6" wall studs, per MBF	—	MBF	1,260.00	—	1,260.00
6" x 4" headers, per MBF	—	MBF	1,530.00	—	1,530.00
6" x 8", 10", 12" and 14" headers, per MBF	—	MBF	2,220.00	—	2,220.00
To 3' wide (6" x 4" header)	B1@1.11	Ea	59.20	37.90	97.10
Over 3' to 4' wide (6" x 6" header)	B1@1.39	Ea	70.10	47.40	117.50
Over 4' to 5' wide (6" x 6" header)	B1@1.66	Ea	78.00	56.60	134.60
Over 5' to 6' wide (6" x 8" header)	B1@1.94	Ea	99.20	66.20	165.40
Over 6' to 8' wide (6" x 10" header)	B1@2.22	Ea	156.00	75.70	231.70
Over 8' to 10' wide (6" x 12" header)	B1@2.22	Ea	204.00	75.70	279.70
Over 10' to 12' wide (6" x 14" header)	B1@2.50	Ea	259.00	85.30	344.30
Add per foot of height for 6" walls over 8' in height	—	LF	7.55	—	7.55

Carpentry, Detailed Breakdown

Craft@Hrs Unit Material Labor Total

Window opening framing In wall studs, based on walls 8' in height. Costs shown are per window opening and include header of appropriate size, sub-sill plate (double sub-sill if opening is 8' wide or wider), double vertical studs each side of openings less than 8' wide (triple vertical studs each side of openings 8' wide or wider), top and bottom cripples, blocking, nails and normal waste. Figures in parentheses indicate header size.

2" x 4" wall studs, Std & Btr, opening size shown is width of finished opening

2" x 4" wall studs, per MBF	—	MBF	1,240.00	—	1,240.00
4" x 4" and 4" x 6" headers, per MBF	—	MBF	1,530.00	—	1,530.00
4" x 8", 10", 12" and 14" headers, per MBF	—	MBF	1,660.00	—	1,660.00
To 2' wide (4" x 4" header)	B1@1.00	Ea	33.70	34.10	67.80
Over 2' to 3' wide (4" x 4" header)	B1@1.17	Ea	42.00	39.90	81.90
Over 3' to 4' wide (4" x 6" header)	B1@1.45	Ea	51.50	49.50	101.00
Over 4' to 5' wide (4" x 6" header)	B1@1.73	Ea	57.60	59.00	116.60
Over 5' to 6' wide (4" x 8" header)	B1@2.01	Ea	71.10	68.60	139.70
Over 6' to 7' wide (4" x 8" header)	B1@2.29	Ea	90.40	78.10	168.50
Over 7' to 8' wide (4" x 10" header)	B1@2.57	Ea	109.00	87.70	196.70
Over 8' to 10' wide (4" x 12" header)	B1@2.57	Ea	136.00	87.70	223.70
Over 10' to 12' wide (4" x 14" header)	B1@2.85	Ea	177.00	97.20	274.20
Add per foot of height for walls					
over 8' high	—	LF	4.94	—	4.94

2" x 6" wall studs, Std & Btr, opening size as shown

2" x 6" wall studs, per MBF	—	MBF	1,260.00	—	1,260.00
4" x 4" and 6" x 4" headers, per MBF	—	MBF	1,530.00	—	1,530.00
6" x 6", 8", 10", 12" and 14" headers, per MBF	—	MBF	2,220.00	—	2,220.00
To 2' wide (4 x 4)	B1@1.17	Ea	43.30	39.90	83.20
Over 2' to 3' wide (6" x 4" header)	B1@1.45	Ea	55.10	49.50	104.60
Over 3' to 4' wide (6" x 6" header)	B1@1.73	Ea	76.90	59.00	135.90
Over 4' to 5' wide (6" x 6" header)	B1@2.01	Ea	91.00	68.60	159.60
Over 5' to 6' wide (6" x 8" header)	B1@2.29	Ea	109.00	78.10	187.10
Over 6' to 8' wide (6" x 10" header)	B1@2.85	Ea	169.00	97.20	266.20
Over 8' to 10' wide (6" x 12" header)	B1@2.85	Ea	229.00	97.20	326.20
Over 8' to 12' wide (6" x 14" header)	B1@3.13	Ea	289.00	107.00	396.00
Add per foot of height for 6" walls					
over 8' high	—	LF	7.55	—	7.55

Bracing See also sheathing for plywood bracing and shear panels

Let-in wall bracing, using standard and better lumber

1" x 4"	B1@.021	LF	.73	.72	1.45
1" x 6"	B1@.027	LF	1.06	.92	1.98
2" x 4"	B1@.035	LF	.82	1.19	2.01

Steel strap bracing, 1-1/4" wide

9'6" or 11'6" lengths	B1@.010	LF	.96	.34	1.30
-----------------------	---------	----	-----	-----	------

Steel "V" bracing, 3/4" x 3/4"

9'6" or 11'6" lengths	B1@.010	LF	1.46	.34	1.80
-----------------------	---------	----	------	-----	------

Temporary wood frame wall bracing, assumes salvage at 50% and 3 uses

1" x 4" Std & Btr	B1@.006	LF	.18	.20	.38
1" x 6" Std & Btr	B1@.010	LF	.26	.34	.60
2" x 4" utility	B1@.012	LF	.21	.41	.62
2" x 6" utility	B1@.018	LF	.31	.61	.92

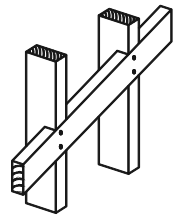

Carpentry, Detailed Breakdown

	Craft@Hrs	Unit	Material	Labor	Total
Fireblocks Installed in wood frame walls, per LF of wall to be blocked. Figures in parentheses indicate board feet of fire blocking per linear foot of wall including 10% waste. See also Bridging and Backing and Nailers in this section					
2" x 3" blocking, Std & Btr					
2" x 3" fireblocks, 16" centers, per MBF	—	MBF	1,390.00	—	1,390.00
12" OC members (.48 BF per LF)	B1@.016	LF	.67	.55	1.22
16" OC members (.50 BF per LF)	B1@.015	LF	.69	.51	1.20
20" OC members (.51 BF per LF)	B1@.012	LF	.71	.41	1.12
24" OC members (.52 BF per LF)	B1@.010	LF	.72	.34	1.06
2" x 4" blocking, Std & Btr					
2" x 4" fireblocks, 16" centers, per MBF	—	MBF	1,240.00	—	1,240.00
12" OC members (.64 BF per LF)	B1@.020	LF	.79	.68	1.47
16" OC members (.67 BF per LF)	B1@.015	LF	.83	.51	1.34
20" OC members (.68 BF per LF)	B1@.012	LF	.84	.41	1.25
24" OC members (.69 BF per LF)	B1@.010	LF	.85	.34	1.19
2" x 6" blocking, Std & Btr					
2" x 6" fireblocks, 24" centers, per MBF	—	MBF	1,260.00	—	1,260.00
12" OC members (.96 BF per LF)	B1@.021	LF	1.21	.72	1.93
16" OC members (1.00 BF per LF)	B1@.016	LF	1.26	.55	1.81
20" OC members (1.02 BF per LF)	B1@.012	LF	1.28	.41	1.69
24" OC members (1.03 BF per LF)	B1@.010	LF	1.30	.34	1.64
Beams Std & Btr. Installed over wall openings and around floor, ceiling and roof openings or where a flush beam is called out in the plans, including 10% waste. Do not use these beams for door or window headers in framed walls, use door or window opening framing assemblies.					
2" x 6" beams, per MBF	—	MBF	1,260.00	—	1,260.00
2" x 8" beams, per MBF	—	MBF	1,110.00	—	1,110.00
2" x 10" beams, per MBF	—	MBF	1,180.00	—	1,180.00
2" x 12" beams, per MBF	—	MBF	1,350.00	—	1,350.00
4" x 6" beams, per MBF	—	MBF	1,530.00	—	1,530.00
4" x 8", 10", 12", 14" beams, per MBF	—	MBF	1,660.00	—	1,660.00
6" x 6", 8", 10", 12", 14" beams, per MBF	—	MBF	2,220.00	—	2,220.00
2" x 6" (1.10 BF per LF)	B1@.028	LF	1.38	.96	2.34
2" x 8" (1.47 BF per LF)	B1@.037	LF	1.63	1.26	2.89
2" x 10" (1.83 BF per LF)	B1@.046	LF	2.17	1.57	3.74
2" x 12" (2.20 BF per LF)	B1@.057	LF	2.98	1.94	4.92
4" x 6" (2.20 BF per LF)	B1@.057	LF	3.36	1.94	5.30
4" x 8" (2.93 BF per LF)	B1@.073	LF	4.87	2.49	7.36
4" x 10" (3.67 BF per LF)	B1@.094	LF	6.10	3.21	9.31
4" x 12" (4.40 BF per LF)	B1@.112	LF	7.31	3.82	11.13
4" x 14" (5.13 BF per LF)	B1@.115	LF	8.52	3.92	12.44
6" x 6" (3.30 BF per LF)	B1@.060	LF	7.34	2.05	9.39
6" x 8" (4.40 BF per LF)	B1@.080	LF	9.79	2.73	12.52
6" x 10" (5.50 BF per LF)	B1@.105	LF	12.20	3.58	15.78
6" x 12" (6.60 BF per LF)	B1@.115	LF	14.70	3.92	18.62
6" x 14" (7.70 BF per LF)	B1@.120	LF	17.10	4.09	21.19
Posts S4S, green. Posts not in wall framing. Material costs include 10% waste. For scheduling purposes, estimate that a two-man crew can complete 100 to 125 LF per 8-hour day.					
4" x 4", 4" x 6" posts, per MBF	—	MBF	1,570.00	—	1,570.00
4" x 8" to 4" x 12" posts, per MBF	—	MBF	1,660.00	—	1,660.00
6" x 6" to 8" x 12" posts, per MBF	—	MBF	2,220.00	—	2,220.00

Carpentry, Detailed Breakdown

	Craft@Hrs	Unit	Material	Labor	Total
4" x 4" per LF	B1@.110	LF	2.30	3.75	6.05
4" x 6" per LF	B1@.120	LF	3.45	4.09	7.54
4" x 8" per LF	B1@.140	LF	4.87	4.78	9.65
4" x 10" per LF	B1@.143	LF	6.09	4.88	10.97
4" x 12" per LF	B1@.145	LF	7.31	4.95	12.26
6" x 6" per LF	B1@.145	LF	7.34	4.95	12.29
6" x 8" per LF	B1@.145	LF	8.09	4.95	13.04
6" x 10" per LF	B1@.147	LF	12.20	5.01	17.21
6" x 12" per LF	B1@.150	LF	14.70	5.12	19.82
8" x 8" per LF	B1@.150	LF	13.10	5.12	18.22
8" x 10" per LF	B1@.155	LF	16.30	5.29	21.59
8" x 12" per LF	B1@.166	LF	19.60	5.66	25.26

Ceiling joists and soffits Per SF of area covered. Figures in parentheses indicate board feet per square foot of ceiling including end joists, header joists, and 5% waste. No beams, bridging, blocking, or ledger strips included. Deduct for openings over 25 SF. Costs shown are based on a job with 1,000 SF of area covered. For scheduling purposes, estimate that a two-man crew can complete 650 SF of area per 8-hour day for 12" center to center framing; 800 SF for 16" OC; 950 SF for 20" OC; or 1,100 SF for 24" OC.

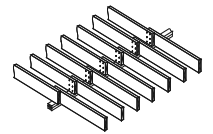

2" x 4", Std & Btr grade					
2" x 4" ceiling joists, per MBF	—	MBF	1,240.00	—	1,240.00
12" centers (.78 BF per SF)	B1@.026	SF	.96	.89	1.85
16" centers (.59 BF per SF)	B1@.020	SF	.73	.68	1.41
20" centers (.48 BF per SF)	B1@.016	SF	.59	.55	1.14
24" centers (.42 BF per SF)	B1@.014	SF	.52	.48	1.00
2" x 6", Std & Btr grade					
2" x 6" ceiling joists, per MBF	—	MBF	1,260.00	—	1,260.00
12" centers (1.15 BF per SF)	B1@.026	SF	.89	.89	1.78
16" centers (.88 BF per SF)	B1@.020	SF	1.11	.68	1.79
20" centers (.72 BF per SF)	B1@.016	SF	.91	.55	1.46
24" centers (.63 BF per SF)	B1@.014	SF	.79	.48	1.27
2" x 8", Std & Btr grade					
2" x 8" ceiling joists, per MBF	—	MBF	1,110.00	—	1,110.00
12" centers (1.53 BF per SF)	B1@.028	SF	1.69	.96	2.65
16" centers (1.17 BF per SF)	B1@.022	SF	1.29	.75	2.04
20" centers (.96 BF per SF)	B1@.018	SF	1.06	.61	1.67
24" centers (.84 BF per SF)	B1@.016	SF	.93	.55	1.48
2" x 10", Std & Btr grade					
2" x 10" ceiling joists, per MBF	—	MBF	1,180.00	—	1,180.00
12" centers (1.94 BF per SF)	B1@.030	SF	2.30	1.02	3.32
16" centers (1.47 BF per SF)	B1@.023	SF	1.74	.78	2.52
20" centers (1.21 BF per SF)	B1@.019	SF	1.43	.65	2.08
24" centers (1.04 BF per SF)	B1@.016	SF	1.23	.55	1.78
2" x 12", Std & Btr grade					
2" x 12" ceiling joists, per MBF	—	MBF	1,350.00	—	1,350.00
12" centers (2.30 BF per SF)	B1@.033	SF	3.11	1.13	4.24
16" centers (1.76 BF per SF)	B1@.025	SF	2.38	.85	3.23
20" centers (1.44 BF per SF)	B1@.020	SF	1.95	.68	2.63
24" centers (1.26 BF per SF)	B1@.018	SF	1.70	.61	2.31

Catwalks 1" x 6" solid planking walkway, #2 & Btr grade
(0.50 BF per SF)

	B1@.017	SF	1.88	.58	2.46
--	---------	----	------	-----	------

Carpentry, Detailed Breakdown

Craft@Hrs Unit Material Labor Total

Backing and nailers Std & Btr, for wall finishes, "floating" backing for drywall ceilings, trim, z-bar, appliances and fixtures, etc. See also Bridging and Fireblocking in this section. Figures in parentheses show board feet per LF including 10% waste.

1" x 4" (.37 BF per LF)	B1@.011	LF	.82	.38	1.20
1" x 6" (.55 BF per LF)	B1@.017	LF	1.30	.58	1.88
1" x 8" (.73 BF per LF)	B1@.022	LF	1.73	.75	2.48
1" x 10" (.92 BF per LF)	B1@.027	LF	1.64	.92	2.56
1" x 12" (1.10 BF per LF)	B1@.030	LF	2.59	1.02	3.61
2" x 4" (.73 BF per LF)	B1@.023	LF	.90	.78	1.68
2" x 6" (1.10 BF per LF)	B1@.034	LF	1.38	1.16	2.54
2" x 8" (1.47 BF per LF)	B1@.045	LF	1.63	1.53	3.16
2" x 10" (1.83 BF per LF)	B1@.057	LF	2.17	1.94	4.11
3" x 10" (2.76 BF per LF)	B1@.064	LF	3.70	2.18	5.88
1" x 8" Azec core	B1@.042	LF	5.23	1.43	6.66

Ledger strips Std & Btr, nailed to faces of studs, beams, girders, joists, etc. See also Ribbons in this section for let-in type. Figures in parentheses indicate board feet per LF including 10% waste.

1" x 2", 3" or 4" ledger, per MBF	—	MBF	2,210.00	—	2,210.00
2" x 2", 3" or 4" ledger, per MBF	—	MBF	1,240.00	—	1,240.00
1" x 2" (.18 BF per LF)	B1@.010	LF	.40	.34	.74
1" x 3" (.28 BF per LF)	B1@.010	LF	.62	.34	.96
1" x 4" (.37 BF per LF)	B1@.010	LF	.82	.34	1.16
2" x 2" (.37 BF per LF)	B1@.010	LF	.46	.34	.80
2" x 3" (.55 BF per LF)	B1@.010	LF	.68	.34	1.02
2" x 4" (.73 BF per LF)	B1@.010	LF	.90	.34	1.24

Ribbons (Ribbands) Let in to wall framing. See also Ledgers in this section. Figures in parentheses indicate board feet per LF including 10% waste.

1" x 3", 4" or 6" ribbon, per MBF	—	MBF	2,210.00	—	2,210.00
2" x 3", 4" ribbon, per MBF	—	MBF	1,240.00	—	1,240.00
2" x 6" ribbon, per MBF	—	MBF	1,260.00	—	1,260.00
2" x 8" ribbon, per MBF	—	MBF	1,110.00	—	1,110.00
1" x 3", Std & Btr (.28 BF per LF)	B1@.020	LF	.62	.68	1.30
1" x 4", Std & Btr (.37 BF per LF)	B1@.020	LF	.82	.68	1.50
1" x 6", Std & Btr (.55 BF per LF)	B1@.030	LF	1.22	1.02	2.24
2" x 3", Std & Btr (.55 BF per LF)	B1@.041	LF	.68	1.40	2.08
2" x 4", Std & Btr (.73 BF per LF)	B1@.041	LF	.90	1.40	2.30
2" x 6", Std & Btr (1.10 BF per LF)	B1@.045	LF	1.38	1.53	2.91
2" x 8", Std & Btr (1.47 BF per LF)	B1@.045	LF	1.63	1.53	3.16

Rafters Flat, shed, or gable roofs, up to 5 in 12 slope (5/24 pitch), maximum 25' span. Figures in parentheses indicate board feet per SF of actual roof surface area (not roof plan area), including rafters, ridge boards, collar beams and normal waste, but no blocking, bracing, purlins, curbs, or gable walls.

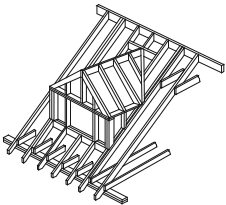

2" x 4", Std & Btr					
2" x 4" rafters, per MBF	—	MBF	1,240.00	—	1,240.00
12" centers (.89 BF per SF)	B1@.021	SF	1.10	.72	1.82
16" centers (.71 BF per SF)	B1@.017	SF	.88	.58	1.46
24" centers (.53 BF per SF)	B1@.013	SF	.66	.44	1.10

Carpentry, Detailed Breakdown

	Craft@Hrs	Unit	Material	Labor	Total
2" x 6", Std & Btr					
2" x 6" rafters, per MBF	—	MBF	1,260.00	—	1,260.00
12" centers (1.29 BF per SF)	B1@.029	SF	1.62	.99	2.61
16" centers (1.02 BF per SF)	B1@.023	SF	1.28	.78	2.06
24" centers (.75 BF per SF)	B1@.017	SF	.94	.58	1.52
2" x 8", Std & Btr					
2" x 8" rafters, per MBF	—	MBF	1,110.00	—	1,110.00
12" centers (1.71 BF per SF)	B1@.036	SF	1.89	1.23	3.12
16" centers (1.34 BF per SF)	B1@.028	SF	1.48	.96	2.44
24" centers (1.12 BF per SF)	B1@.024	SF	1.24	.82	2.06
2" x 10", Std & Btr					
2" x 10" rafters, per MBF	—	MBF	1,180.00	—	1,180.00
12" centers (2.12 BF per SF)	B1@.039	SF	2.51	1.33	3.84
16" centers (1.97 BF per SF)	B1@.036	SF	2.33	1.23	3.56
24" centers (1.21 BF per SF)	B1@.022	SF	1.43	.75	2.18
2" x 12", Std & Btr					
2" x 12" rafters, per MBF	—	MBF	1,350.00	—	1,350.00
12" centers (2.52 BF per SF)	B1@.045	SF	3.41	1.53	4.94
16" centers (1.97 BF per SF)	B1@.035	SF	2.67	1.19	3.86
24" centers (1.43 BF per SF)	B1@.026	SF	1.93	.89	2.82
Add for hip roof	B1@.007	SF	—	.24	.24
Add for slope over 5 in 12	B1@.015	SF	—	.51	.51
Trimmers and curbs At stairwells, skylights, dormers, etc. Figures in parentheses show board feet per LF, Std & Btr grade, including 10% waste.					
2" x 4" (.73 BF per LF)	B1@.018	LF	.90	.61	1.51
2" x 6" (1.10 BF per LF)	B1@.028	LF	1.38	.96	2.34
2" x 8" (1.47 BF per LF)	B1@.038	LF	1.63	1.30	2.93
2" x 10" (1.83 BF per LF)	B1@.047	LF	2.17	1.60	3.77
2" x 12" (2.20 BF per LF)	B1@.057	LF	2.98	1.94	4.92
Collar beams & collar ties Std & Btr grade, including 10% waste					
Collar beams, 2" x 6"	B1@.013	LF	1.38	.44	1.82
Collar ties, 1" x 6"	B1@.006	LF	1.30	.20	1.50
Purlins (Purling) Std & Btr, installed below roof rafters. Figures in parentheses indicate board feet per LF including 5% waste.					
2" x 4" (.70 BF per LF)	B1@.012	LF	.87	.41	1.28
2" x 6" (1.05 BF per LF)	B1@.017	LF	1.32	.58	1.90
2" x 8" (1.40 BF per LF)	B1@.023	LF	1.55	.78	2.33
2" x 10" (1.75 BF per LF)	B1@.027	LF	2.07	.92	2.99
2" x 12" (2.10 BF per LF)	B1@.030	LF	2.84	1.02	3.86
4" x 6" (2.10 BF per LF)	B1@.034	LF	3.21	1.16	4.37
4" x 8" (2.80 BF per LF)	B1@.045	LF	4.17	1.53	5.70
Dormer studs Std & Btr, per square foot of wall area, including 10% waste					
2" x 4" (.84 BF per SF)	B1@.033	SF	1.04	1.13	2.17
Roof trusses 24" OC, any slope from 3 in 12 to 12 in 12, total height not to exceed 12' high from bottom chord to highest point on truss. Prices for trusses over 12' high will be up to 100% higher. Square foot (SF) costs are per square foot of horizontal area to be covered.					
Scissor truss					
2" x 4" top and bottom chords					
Up to 38' span	B1@.022	SF	5.75	.75	6.50
40' to 50' span	B1@.028	SF	7.18	.96	8.14

Carpentry, Detailed Breakdown

	Craft@Hrs	Unit	Material	Labor	Total
Fink truss "W" (conventional roof truss)					
2" x 4" top and bottom chords					
Up to 38' span	B1@.017	SF	4.99	.58	5.57
40' to 50' span	B1@.022	SF	6.03	.75	6.78
2" x 6" top and bottom chords					
Up to 38' span	B1@.020	SF	6.19	.68	6.87
40' to 50' span	B1@.026	SF	7.43	.89	8.32
Truss with gable fill at 16" OC					
28' span, 5 in 12 slope	B1@.958	Ea	116.00	32.70	148.70
32' span, 5 in 12 slope	B1@1.26	Ea	510.00	43.00	553.00
40' span, 5 in 12 slope	B1@1.73	Ea	718.00	59.00	777.00
Fascia Material column includes 10% waste					
White Wood, #3 & Btr					
1" x 4", per MBF	—	MBF	3,590.00	—	3,590.00
1" x 6", per MBF	—	MBF	3,860.00	—	3,860.00
1" x 8", per MBF	—	MBF	3,930.00	—	3,930.00
1" x 4", per LF	B1@.044	LF	1.31	1.50	2.81
1" x 6", per LF	B1@.044	LF	2.12	1.50	3.62
1" x 8", per LF	B1@.051	LF	2.88	1.74	4.62
Hem-fir, S4S, dry, Std and Btr					
2" x 6", per MBF	—	MBF	1,390.00	—	1,390.00
2" x 8", per MBF	—	MBF	1,470.00	—	1,470.00
2" x 10", per MBF	—	MBF	1,120.00	—	1,120.00
2" x 6", per LF	B1@.044	LF	1.52	1.50	3.02
2" x 8", per LF	B1@.051	LF	2.15	1.74	3.89
2" x 10", per LF	B1@.051	LF	2.06	1.74	3.80
Redwood, S4S kiln dried, clear					
1" x 4", per MBF	—	MBF	3,740.00	—	3,740.00
1" x 6", per MBF	—	MBF	5,450.00	—	5,450.00
1" x 8", per MBF	—	MBF	3,640.00	—	3,640.00
2" x 4", per MBF	—	MBF	2,800.00	—	2,800.00
2" x 6", per MBF	—	MBF	2,660.00	—	2,660.00
2" x 8", per MBF	—	MBF	2,930.00	—	2,930.00
1" x 4", per LF	B1@.044	LF	1.37	1.50	2.87
1" x 6", per LF	B1@.044	LF	3.00	1.50	4.50
1" x 8", per LF	B1@.051	LF	2.67	1.74	4.41
2" x 4", per LF	B1@.044	LF	2.05	1.50	3.55
2" x 6", per LF	B1@.044	LF	2.93	1.50	4.43
2" x 8", per LF	B1@.051	LF	4.30	1.74	6.04
Sheathing, roof Per SF of roof surface including 10% waste					
CDX plywood sheathing, rough					
1/2"	B1@.013	SF	1.47	.44	1.91
1/2", 4-ply	B1@.013	SF	1.70	.44	2.14
1/2", 5-ply	B1@.013	SF	2.20	.44	2.64
5/8", 4-ply	B1@.013	SF	1.65	.44	2.09
5/8", 5-ply	B1@.013	SF	2.55	.44	2.99
3/4"	B1@.013	SF	1.68	.44	2.12
OSB sheathing					
7/16"	B1@.013	SF	1.16	.44	1.60
1/2"	B1@.013	SF	1.55	.44	1.99
5/8"	B1@.013	SF	1.81	.44	2.25
3/4"	B1@.014	SF	2.09	.48	2.57

Carpentry, Detailed Breakdown

	Craft@Hrs	Unit	Material	Labor	Total
7/8"	B1@.014	SF	4.12	.48	4.60
1-1/8"	B1@.015	SF	5.98	.51	6.49
Add for hip roof	B1@.007	SF	—	.24	.24
Add for steep pitch or cut-up roof	B1@.015	SF	—	.51	.51
Board sheathing, 1" x 6" or 1" x 8" utility T&G laid diagonal					
1" utility T&G lumber, per MBF	—	MBF	2,610.00	—	2,610.00
(1.13 BF per SF)	B1@.026	SF	3.24	.89	4.13
Add for hip roof	B1@.007	SF	—	.24	.24
Add for steep pitch or cut-up roof	B1@.015	SF	—	.51	.51

Roof decking Std & Btr grade. See also Sheathing in this section. Flat, shed, or gable roofs to 5 in 12 slope (5/24 pitch). Figures in parentheses indicate board feet per SF of actual roof area (not roof plan area), including 5% waste.

2" x 6", per MBF	—	MBF	1,260.00	—	1,260.00
2" x 8", per MBF	—	MBF	1,110.00	—	1,110.00
3" x 6", per MBF	—	MBF	1,220.00	—	1,220.00
2" x 6" (2.28 BF per SF)	B1@.043	SF	2.87	1.47	4.34
2" x 8" (2.25 BF per SF)	B1@.043	SF	2.52	1.47	3.99
3" x 6" (3.43 BF per SF)	B1@.047	SF	4.15	1.60	5.75
Add for steep pitch or cut-up roof	B1@.019	SF	—	.65	.65

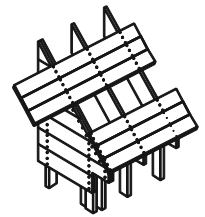

Cant strips Std & Btr grade lumber

2" x 4" beveled	B1@.020	LF	1.36	.68	2.04
For short or cut-up runs	B1@.030	LF	1.36	1.02	2.38

Furring Per SF of surface area to be covered. Figures in parentheses show coverage including 7% waste, typical job.

1" furring, per MBF	—	MBF	2,210.00	—	2,210.00
Over masonry, Utility grade					
12" OC, 1" x 2" (.24 BF per SF)	B1@.025	SF	.53	.85	1.38
16" OC, 1" x 2" (.20 BF per SF)	B1@.020	SF	.44	.68	1.12
20" OC, 1" x 2" (.17 BF per SF)	B1@.018	SF	.38	.61	.99
24" OC, 1" x 2" (.15 BF per SF)	B1@.016	SF	.33	.55	.88
12" OC, 1" x 3" (.36 BF per SF)	B1@.025	SF	.80	.85	1.65
16" OC, 1" x 3" (.29 BF per SF)	B1@.020	SF	.64	.68	1.32
20" OC, 1" x 3" (.25 BF per SF)	B1@.018	SF	.55	.61	1.16
24" OC, 1" x 3" (.22 BF per SF)	B1@.016	SF	.49	.55	1.04
Over wood frame, Utility grade					
12" OC, 1" x 2" (.24 BF per SF)	B1@.016	SF	.53	.55	1.08
16" OC, 1" x 2" (.20 BF per SF)	B1@.013	SF	.44	.44	.88
20" OC, 1" x 2" (.17 BF per SF)	B1@.011	SF	.38	.38	.76
24" OC, 1" x 2" (.15 BF per SF)	B1@.010	SF	.33	.34	.67
12" OC, 1" x 3" (.36 BF per SF)	B1@.016	SF	.80	.55	1.35
16" OC, 1" x 3" (.29 BF per SF)	B1@.013	SF	.64	.44	1.08
20" OC, 1" x 3" (.25 BF per SF)	B1@.011	SF	.55	.38	.93
24" OC, 1" x 3" (.22 BF per SF)	B1@.010	SF	.49	.34	.83
Over wood subfloor, Utility grade					
12" OC, 1" x 2" (.24 BF per SF)	B1@.033	SF	.53	1.13	1.66
16" OC, 1" x 2" (.20 BF per SF)	B1@.028	SF	.44	.96	1.40
20" OC, 1" x 2" (.17 BF per SF)	B1@.024	SF	.38	.82	1.20
24" OC, 1" x 2" (.15 BF per SF)	B1@.021	SF	.33	.72	1.05

Carpentry, Detailed Breakdown

	Craft@Hrs	Unit	Material	Labor	Total
2" furring, per MBF	—	MBF	1,240.00	—	1,240.00
12" OC, 2" x 2" Std & Btr (.48 BF per SF)	B1@.033	SF	.59	1.13	1.72
16" OC, 2" x 2" Std & Btr (.39 BF per SF)	B1@.028	SF	.48	.96	1.44
20" OC, 2" x 2" Std & Btr (.34 BF per SF)	B1@.024	SF	.42	.82	1.24
24" OC, 2" x 2" Std & Btr (.30 BF per SF)	B1@.021	SF	.37	.72	1.09
Grounds Screeds for plaster or stucco, #3, 1" x 2" lumber. Based on .18 BF per LF including 10% waste.					
1" grounds, per MBF	—	MBF	2,210.00	—	2,210.00
Over masonry	B1@.047	LF	.40	1.60	2.00
Over wood	B1@.038	LF	.40	1.30	1.70
Sheathing, wall Per SF of wall surface, including 5% waste					
BC plywood sheathing, plugged and touch sanded, interior grade					
1/4"	B1@.013	SF	1.04	.44	1.48
3/8"	B1@.015	SF	1.39	.51	1.90
1/2"	B1@.016	SF	1.75	.55	2.30
5/8"	B1@.018	SF	1.55	.61	2.16
3/4"	B1@.020	SF	1.77	.68	2.45
AB marine grade Douglas fir plywood					
1/2", 5-ply	B1@.016	SF	3.39	.55	3.94
3/4", 7-ply	B1@.020	SF	3.72	.68	4.40
OSB sheathing					
1/4"	B1@.013	SF	.83	.44	1.27
3/8"	B1@.015	SF	1.50	.51	2.01
7/16"	B1@.015	SF	1.11	.51	1.62
1/2"	B1@.016	SF	1.48	.55	2.03
5/8"	B1@.018	SF	1.72	.61	2.33
3/4"	B1@.018	SF	1.99	.61	2.60
7/8"	B1@.020	SF	3.93	.68	4.61
1-1/8"	B1@.020	SF	5.71	.68	6.39
Board sheathing 1" x 6" or 1" x 8" utility T&G					
1" x 6" or 8" utility T&G, per MBF	—	MBF	2,370.00	—	2,370.00
(1.13 BF per SF)	B1@.020	SF	2.68	.68	3.36
Add for diagonal patterns	B1@.006	SF	—	.20	.20
Sleepers Std & Btr pressure treated lumber, including 5% waste, laid flat 16" OC over a waterproof membrane spread on a concrete slab and set with shot fasteners					
2" x 4" sleepers, per MBF	—	MBF	1,620.00	—	1,620.00
2" x 4" sleepers, per LF	B1@.017	LF	1.70	.58	2.28
2" x 4" sleepers, per SF of floor slab	B1@.017	SF	1.00	.58	1.58
Add for waterproof membrane	B1@.002	SF	.10	.07	.17
Add for shot fasteners, 24" OC, per SF of slab	B1@.009	SF	.11	.31	.42
Add for taper cuts on sleepers, per cut	B1@.009	Ea	—	.31	.31
Finish Carpentry These figures assume all materials to be installed are supplied by others. Labor costs assume good quality stain-grade work up to 9 feet above floor level. Paint-grade work will cost from 20% to 33% less. Add the cost of scaffolding, staining or painting, if required.					
Blocking and backing Installation before drywall is hung. Cost per piece of blocking or backing set					
2" x 4" backing or blocking	BC@.040	Ea	—	1.51	1.51
2" x 4" strongback 10' to 16' long screwed to ceiling joists	BC@.350	Ea	—	13.20	13.20

Carpentry, Finish

	Craft@Hrs	Unit	Material	Labor	Total
Furring Nailed over studs and adjusted with shims to bring the wall surface flush. Costs will be higher if the wall plane is very uneven or if the furred wall has to be exceptionally even.					
Cost per linear foot of furring installed					
1" x 4" furring, few shims required	BC@.010	LF	—	.38	.38
Straightening wall studs Costs per stud straightened					
Cut saw kerf and drive shim or screw into the kerf					
reinforce with a plywood scab	BC@.300	Ea	—	11.30	11.30
Remove and replace a badly warped stud	BC@.300	Ea	—	11.30	11.30
Cased openings Install jambs only. See costs for casing below. Costs per opening cased					
Opening to 4' wide	BC@.800	Ea	—	30.10	30.10
Openings over 4' wide	BC@1.05	Ea	—	39.50	39.50
Exterior doors Based on hanging doors in prepared openings. No lockset, or casing included. See the sections that follow. Costs will be higher if the framing has to be adjusted before the door can be set.					
Hang a new door in an existing jamb					
Cut door, set butt hinges, install door	BC@1.46	Ea	—	55.00	55.00
Prehung flush or panel 1-3/4" thick solid core single doors, with felt insulation, based on an adjustable metal sill					
Up to 3' wide	BC@.750	Ea	—	28.20	28.20
Over 3' wide	BC@1.25	Ea	—	47.10	47.10
Add for door with sidelights	BC@.750	Ea	—	28.20	28.20
Sliding glass doors, opening to 8' wide	BC@1.75	Ea	—	65.90	65.90
French doors, 1-3/4" thick, to 6' wide	BC@1.75	Ea	—	65.90	65.90
Interior doors Based on hanging 1-3/8" hollow core doors in prepared openings. No locksets or casing included. See the sections that follow.					
Prehung interior doors					
	BC@.500	Ea	—	18.80	18.80
Add for assembling a factory-cut					
mortised and rabbeted jamb	BC@.200	Ea	—	7.53	7.53
Pocket doors					
Assemble and install the door frame	BC@.981	Ea	—	36.90	36.90
Install door and valances in existing frame	BC@.500	Ea	—	18.80	18.80
Bifold doors installed in cased openings. See costs for cased openings above					
Single bifold door to 4' wide	BC@.700	Ea	—	26.40	26.40
Double bifold door to 8' wide, pair of doors	BC@1.20	Pr	—	45.20	45.20
Bypass closet doors installed on a track in a cased opening. See cased opening manhours above					
Double doors, per opening	BC@.660	Ea	—	24.90	24.90
Triple doors, per opening	BC@1.00	Ea	—	37.70	37.70
Rehang most hollow core doors in an existing opening,					
re-shim jamb and plane door, per door	BC@1.50	Ea	—	56.50	56.50
Rehang large or heavy solid core doors in an existing opening,					
re-shim jamb and plane door, per door	BC@1.75	Ea	—	65.90	65.90
Correcting a sagging door hinge. Remove door from the jamb, remove hinge leaf,					
deepen the mortise and rehang the door	BC@.600	Ea	—	22.60	22.60
Hang a new door in an existing jamb. Mark the door to fit opening, cut the door, set butt hinges, install door in the jamb, install door hardware					
Per door hung	BC@1.75	Ea	—	65.90	65.90
Prehanging doors off site. Cost per door hung, excluding door cost					
Make and assemble frame, cost per frame	BC@.750	Ea	—	28.20	28.20

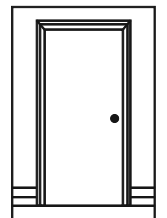
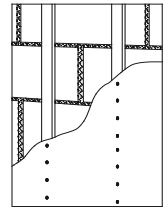

Carpentry, Finish

	Craft@Hrs	Unit	Material	Labor	Total
Set hinge on door and frame, panel or flush door, per hinge					
Using jigs and router	BC@.160	Ea	—	6.03	6.03
Using hand tools	BC@.500	Ea	—	18.80	18.80
Add for French doors, per door	BC@.250	Ea	—	9.42	9.42

Lockset installation Set in either a solid core or hollow core door, includes setting the strike plate

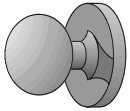

Costs per lockset					
Standard 2-1/8" bore, factory bored	BC@.160	Ea	—	6.03	6.03
Standard 2-1/8" bore, site bored	BC@1.00	Ea	—	37.70	37.70
Mortise type lockset, using a boring machine	BC@1.50	Ea	—	56.50	56.50
Mortise type lockset, using hand tools	BC@3.00	Ea	—	113.00	113.00
Pocket door hardware					
Privacy latch	BC@.500	Ea	—	18.80	18.80
Passage latch	BC@.300	Ea	—	11.30	11.30
Edge pull	BC@.300	Ea	—	11.30	11.30

Setting door stop molding Set at the head and on two sides. Costs per opening

Panel or flush door	BC@.250	Ea	—	9.42	9.42
French door	BC@.330	Ea	—	12.40	12.40
Pocket door	BC@.250	Ea	—	9.42	9.42

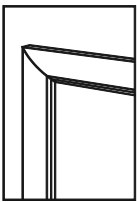

Set casing around a framed opening Mitered or butted molding corners. Costs per opening, per side, using a pneumatic nail gun

Opening to 4' wide using casing to 2-1/4" wide	BC@.250	Ea	—	9.42	9.42
Opening over 4' wide to 8' wide using casing up to 2-1/4" wide	BC@.300	Ea	—	11.30	11.30
Add for casing over 2-1/4" wide to 4" wide	BC@.160	Ea	—	6.03	6.03
Add for block and plinth door casing	BC@.300	Ea	—	11.30	11.30
Add for hand nailing	BC@.275	Ea	—	10.40	10.40

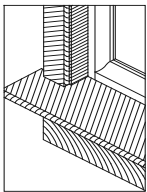

Window trim Based on trim set around prepared openings. Costs per window opening on square windows. Extra tall or extra wide windows will cost more.

Extension jambs cut, assembled, shimmed and installed					
Up to 3/4" thick, 3 or 4 sides, per window	BC@.330	Ea	—	12.40	12.40
Over 3/4" thick, per LF of extension jamb	BC@.100	LF	—	3.77	3.77
Window stool					
Set to sheetrock wraps nailed directly on framing	BC@.500	Ea	—	18.80	18.80
When stool has to be shimmed up from framing					
Add per LF of stool	BC@.050	LF	—	1.88	1.88
Stool set to wooden jambs, per opening	BC@.400	Ea	—	15.10	15.10
When stool has to be shimmed up from jambs					
Add per LF of stool	BC@.050	LF	—	1.88	1.88
Add for mitered returns on horns					
Per opening	BC@.500	Ea	—	18.80	18.80
Window apron molding without mitered returns					
Per opening	BC@.160	Ea	—	6.03	6.03
Window apron molding with mitered returns					
Per opening	BC@.320	Ea	—	12.10	12.10

Carpentry, Finish

	Craft@Hrs	Unit	Material	Labor	Total
Window casing, straight casing with square corners, per opening					
3 sides (stool and apron), up to 5' on any side	BC@.330	Ea	—	12.40	12.40
4 sides (picture frame), up to 5' on any side	BC@.500	Ea	—	18.80	18.80
Add for any side over 5' long, per side	BC@.090	Ea	—	3.39	3.39
Add for angle corners (trapezoid or triangle)					
Per corner	BC@.250	Ea	—	9.42	9.42
Installing a pre-manufactured arched top casing only, per opening					
To 4' wide set against rosettes	BC@.330	Ea	—	12.40	12.40
To 4' wide, mitered corners	BC@.500	Ea	—	18.80	18.80
Over 4' wide set against rosettes	BC@.660	Ea	—	24.90	24.90
Over 4' wide, mitered corners	BC@1.00	Ea	—	37.70	37.70
Ceiling treatments All figures assume a wall height not over 9' with work done from scaffolding. Add the cost of scaffolding					
Set up and dismantle scaffolding, based on a typical 10' x 16' room					
Per room	BC@1.75	Ea	—	65.90	65.90
Wood strip ceiling, T&G or square edged, applied wall to wall with no miters					
Per square foot of ceiling	BC@.050	SF	—	1.88	1.88
Plywood panel ceiling					
Screwed in place, molding strips nailed with a pneumatic nailer, including normal layout					
Per square foot of ceiling covered	BC@.160	SF	—	6.03	6.03
Applied beams, including building up the beam, layout and installation on a flat ceiling					
Per LF of beam applied	BC@.310	LF	—	11.70	11.70
Additional costs for ceiling treatments					
Add for each joint or beam scribed to the wall	BC@.660	Ea	—	24.90	24.90
Add for each corbel	BC@.400	Ea	—	15.10	15.10
Add for each knee brace	BC@.600	Ea	—	22.60	22.60
Cornice or crown molding Including layout and coped joints, per LF of molding					
Up to 2-1/4" wide	BC@.050	LF	—	1.88	1.88
Over 2-1/4" wide to 3-1/2" wide	BC@.060	LF	—	2.26	2.26
Over 3-1/2" wide	BC@.070	LF	—	2.64	2.64
Wall paneling No molding included. See molding below. Costs per square foot of wall covered					
Board wainscot or paneling, 3-1/2" to 5-1/2" wide tongue and groove					
Per square foot of wall covered	BC@.080	SF	—	3.01	3.01
Frame and panel wainscot. Installation only. Add for fabricating the frames and panels					
Per square foot of wall covered	BC@.090	SF	—	3.39	3.39
Add for frame attached with screws and covered with wood plugs	BC@.010	SF	—	.38	.38
Hardwood sheet paneling installed on wood frame or masonry walls					
Per square foot of wall covered	BC@.040	SF	—	1.51	1.51
Add for running molding if required	BC@.040	SF	—	1.51	1.51
Add if vapor barrier must be installed with mastic over a masonry wall	BC@.010	SF	—	.38	.38
Add when 1" x 4" furring is nailed on a masonry wall with a powder-actuated nail gun					
No shimming or straightening included	BC@.020	SF	—	.75	.75
Add if sheet paneling is scribed around stone veneer					
Per linear foot scribed	BC@.150	LF	—	5.65	5.65
Minimum time for scribing sheet paneling	BC@.500	Ea	—	18.80	18.80

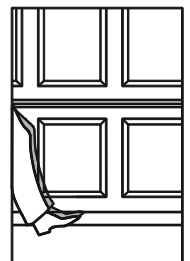
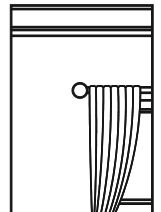
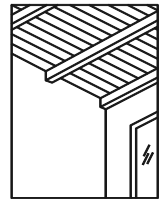

Carpentry, Finish

Craft@Hrs Unit Material Labor Total

Running moldings Single piece mitered installations nailed by hand. Add 100% for two-piece molding.

Costs per LF of molding

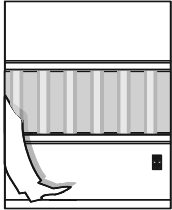

Picture rail	BC@.050	LF	—	1.88	1.88
Chair rail	BC@.040	LF	—	1.51	1.51
Wainscot cap or bed molding	BC@.040	LF	—	1.51	1.51
Baseboard	BC@.040	LF	—	1.51	1.51
Kneewall cap up to 8" wide and 1-1/2" thick. Complex job layout and bed molding will increase costs					
Kneewall cap	BC@.160	LF	—	6.03	6.03

Closet poles and shelving Including layout and installation

1-1/4" closet pole supported with a metal bracket every 32"

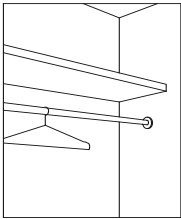

Per LF of pole	BC@.040	LF	—	1.51	1.51
Add for mitered corner joints, per corner	BC@.300	Ea	—	11.30	11.30
3/4" x 12" hat shelf supported with a metal shelf bracket every 32"					
Per LF of shelf	BC@.100	LF	—	3.77	3.77
Add for mitered corner joint, per corner	BC@.300	Ea	—	11.30	11.30
Site-built closet storage unit with drawers using plate biscuit joiners and 3/4" board or plywood stock, including fabrication, layout, assembly and installation					
Per square foot of storage unit face	BC@.680	SF	—	25.60	25.60
Add for each drawer	BC@.850	Ea	—	32.00	32.00

Cabinet installation Including layout, leveling and installation. No fabrication, assembly or countertops included. Costs per cabinet

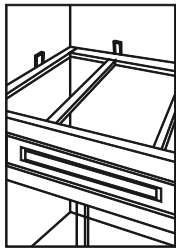

Base cabinets					
Cabinets to 36" wide	BC@.766	Ea	—	28.80	28.80
Cabinets over 36" wide	BC@.911	Ea	—	34.30	34.30
Wall cabinets					
Cabinets to 18" wide	BC@.638	Ea	—	24.00	24.00
Cabinets over 18" to 36" wide	BC@.766	Ea	—	28.80	28.80
Cabinets over 36" wide	BC@1.03	Ea	—	38.80	38.80
Oven or utility cabinets, 70" high, to 30" wide	BC@1.71	Ea	—	64.40	64.40
Filler strip between cabinets, measured, cut, fit and installed					
Per strip installed	BC@.200	Ea	—	7.53	7.53

Fireplace surrounds and mantels Costs will be higher when a mantel or molding must be scribed around irregular masonry surfaces

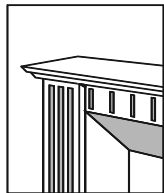

Layout, cutting, fitting, assembling and installing a vertical pilaster on two sides and a horizontal frieze board above the pilasters. Additional moldings will take more time

Costs per linear foot of pilaster and frieze	BC@.350	LF	—	13.20	13.20
Mantel shelf attached to masonry, including cutting, fitting and installation					
Per mantel	BC@.750	Ea	—	28.20	28.20
Installing a prefabricated mantel and fireplace surround					
Per mantel and surround installed	BC@1.50	Ea	—	56.50	56.50

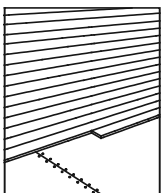

Wood flooring Including layout, vapor barrier and installation with a power nailer. Add for underlayment, sanding and finishing. Borders, feature strips and mitered corners will increase costs.

Costs per square foot of floor covered

Tongue & groove strip flooring					
3/4" x 2-1/4" strips	BF@.036	SF	—	1.25	1.25

Carpentry, Finish

	Craft@Hrs	Unit	Material	Labor	Total
Straight edge plank flooring, 3/4" x 6" to 12" wide					
Set with biscuit joiner plates	BF@.055	SF	—	1.90	1.90
Add for plank flooring					
set with screws and butterfly plugs	BF@.010	SF	—	.35	.35
Filling and sanding a wood floor with drum and disc sanders					
3 passes (60, 80, 100 grit), per square foot	BF@.023	SF	—	.80	.80
Finishing a wood floor, including filler, shellac, polyurethane or waterborne urethane	BF@.024	SF	—	.83	.83

Skirt boards for stairways Including layout, fitting, assembly and installation. Based on a 9' floor-to-floor rise where the stair carriage has already been installed by others. Costs will be higher if re-cutting, shimming, or adjusting of an existing stair carriage is required.

Cutting and installing a skirt board on the closed side of a stairway. Costs per skirt board

Treads and risers butted against skirt boards, no dadoes	BC@2.00	Ea	—	75.30	75.30
Treads and risers set in dadoes	BC@3.75	Ea	—	141.00	141.00
Cutting and installing a skirt board on the open side of a stairway					
Risers miter-jointed into the board	BC@5.50	Ea	—	207.00	207.00

Treads and risers for stairs Including layout, cutting, fitting, and installation of treads, risers and typical molding under the tread nosing. Includes a miter return on one side of each tread. Cost per 9' rise of 14 treads and 15 risers

9' rise stairway	BC@2.50	Ea	—	94.20	94.20
------------------	---------	----	---	-------	-------

Handrail for stairs Including layout, cutting, fitting and installation. Based on milled hardwood rail, posts and fittings

Setting newel posts, costs per post	BC@2.50	Ea	—	94.20	94.20
Setting post-to-post handrail					
Costs per 10 linear feet of rail	BC@1.50	Ea	—	56.50	56.50
Setting over-the-post handrail					
Costs per 10 linear feet of rail	BC@2.50	Ea	—	94.20	94.20
Add for each transition fitting					
Turn, easing or gooseneck	BC@1.75	Ea	—	65.90	65.90

Balusters for stair railing Including layout, cutting, fitting and installation. Based on mill-made hardwood balusters. Cost per baluster

Balusters with round top section	BC@.330	Ea	—	12.40	12.40
Balusters with square top section	BC@.750	Ea	—	28.20	28.20

Steel Framing, Rule of Thumb Light-gauge steel framing cost per square foot of living area. Based on steel at \$1.36 per pound. These figures will apply on most crawl space and basement homes. Labor and material cost will be about 30% less for framing over a slab on grade. Complex framing jobs will cost more. The seven lines of cost data under "Steel framing rule of thumb cost breakdown" below show the cost breakdown for framing a house including steel framing, sheathing and blocking. Add \$1.50 to \$3.00 per SF of floor if engineer approval is required (plans not based on code tables). Material costs in this section assume that (1) precut materials are fastened with screws. Labor cost includes layout, assembly, plumb and align.

Low cost house	B1@.223	SF	13.00	7.61	20.61
Medium cost house	B1@.268	SF	14.80	9.14	23.94
Better quality house	B1@.355	SF	20.30	12.10	32.40

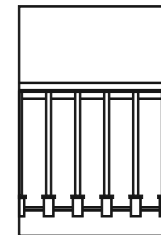
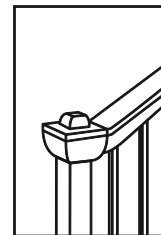
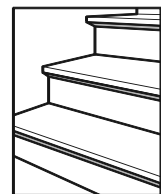
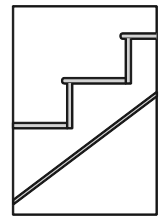

Carpentry, Steel Framing

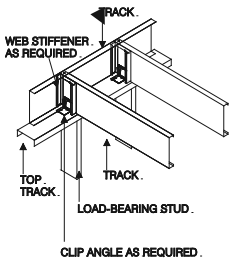

Steel framing rule of thumb cost breakdown Costs per square foot of living area. These figures were used to compile the framing cost for a medium cost home in the section immediately above.

	Craft@Hrs	Unit	Material	Labor	Total
Using light-gauge steel framing materials at	—	Lb	1.36	—	1.36
Using 1/2" OSB subfloor at	—	MSF	1,410.00	—	1,410.00
Using 7/16" OSB roof sheathing at	—	MSF	1,060.00	—	1,060.00
Using 5/8" CDX plywood subfloor at	—	MSF	1,510.00	—	1,510.00
Using 1/2" CDX plywood roof sheathing at	—	MSF	1,550.00	—	1,550.00
Sills, pier blocks, floor beams (270 Lb per 1,000 SF of floor)	B1@.020	SF	.37	.68	1.05
Floor joists, doublers, blocking, bridging (2,200 Lb per 1,000 SF of floor)	B1@.031	SF	2.99	1.06	4.05
Subflooring, 1/2" OSB sheathing (1,150 SF per 1,000 SF)	B1@.011	SF	1.62	.38	2.00
Subfloor, 5/8" CDX plywood (1,150 SF per 1,000 SF of floor)	B1@.012	SF	1.73	.41	2.14
Layout, studs, top and bottom track, headers, backing, blocking, bracing and framing for openings (2,230 Lb per 1,000 SF of floor)	B1@.102	SF	3.03	3.48	6.51
Ceiling joists, header and end joists, backing, blocking and bracing (1,810 Lb per 1,000 SF of floor)	B1@.050	SF	2.46	1.71	4.17
Rafters, braces, collar beams, ridge members, 8" rafters, 24" OC (2,300 Lb per 1000 SF of roof)	B1@.042	SF	3.13	1.43	4.56
Roof sheathing, 1/2" CDX plywood (1,150 SF per 1,000 SF of roof)	B1@.011	SF	1.78	.38	2.16
Roof sheathing, 7/16" OSB sheathing (1,150 SF per 1,000 SF)	B1@.010	SF	1.21	.34	1.55

Steel lally columns Residential basement columns, 3-1/2" diameter, steel tube

Material only	—	LF	17.00	—	17.00
Add for base or cap plate	—	Ea	6.94	—	6.94
Add for installation, per column to 12' high	B1@.458	Ea	—	15.60	15.60

Wood sill plates for steel framing (At foundation) SYP #2 pressure treated lumber, drilled and installed with foundation bolts at 48" OC, no bolts, nuts or washers included. See also wood plates in this section. Figures in parentheses indicate board feet per LF of foundation, including 5% waste and Wolmanized treatment.

2" x 3" sill plates, per MBF	—	MBF	1,200.00	—	1,200.00
2" x 4" sill plates, per MBF	—	MBF	1,620.00	—	1,620.00
2" x 6" sill plates, per MBF	—	MBF	1,320.00	—	1,320.00
2" x 8" sill plates, per MBF	—	MBF	1,390.00	—	1,390.00
2" x 3" (.53 BF per LF)	B1@.020	LF	.64	.68	1.32
2" x 4" (.70 BF per LF)	B1@.023	LF	1.13	.78	1.91
2" x 6" (1.05 BF per LF)	B1@.024	LF	1.38	.82	2.20
2" x 8" (1.40 BF per LF)	B1@.031	LF	1.95	1.06	3.01

Carpentry, Steel Framing

	Craft@Hrs	Unit	Material	Labor	Total
Foundation anchors Set and aligned in forms before concrete is placed. Equivalent Simpson Strong-Tie Co. model numbers are shown in parentheses					
Mud sill anchors, embedded in concrete, folded over the track and screw fastened					
(MASA)	B1@.051	Ea	1.93	1.74	3.67
Anchor bolts, including bolts, nuts and washers as required					
5/8" x 17" (SSTB16)	B1@.157	Ea	5.67	5.36	11.03
5/8" x 21" (SSTB20)	B1@.158	Ea	11.00	5.39	16.39
5/8" x 25" (SSTB24)	B1@.159	Ea	7.37	5.42	12.79
7/8" x 34" (SSTB34)	B1@.164	Ea	22.60	5.59	28.19
7/8" x 36" (SSTB36)	B1@.167	Ea	31.40	5.70	37.10
Hold down brackets (one per anchor bolt to distribute pull-out forces over a greater area)					
24-1/8" x 10" x 6-1/4" (STHD14)	B1@.165	Ea	31.50	5.63	37.13
24-1/8" x 14" x 6-1/4" (S/HPAHD22)	B1@.169	Ea	19.40	5.76	25.16
13-7/8" x 2-1/2" x 1-1/2" (S/HD8)	B1@.650	Ea	42.50	22.20	64.70
16-1/8" x 2-1/2" x 1-1/2" (S/HD10)	B1@.655	Ea	53.90	22.30	76.20
Steel first floor joists Per SF of area covered. Includes joists and rim joists, typical screws, stiffeners, splices, blocking and strapping. Add the cost of support beams, bridging, trimmer joists and sheathing. See the beam, bridging, trimmer joist and sheathing costs below. Deduct for openings over 25 SF. Figures in parentheses show weight of steel per square foot of floor. Assumes minimal waste.					
Using light-gauge steel framing materials at	—	Lb	1.36	—	1.36
Deduct for multiple spans (supported at midpoint)	—	%	-6.0	—	—
6" steel floor joists 16" OC, 2" flange					
600S200-33 (20 gauge, 1.22 Lbs./SF)	B1@.019	SF	1.66	.65	2.31
600S200-43 (18 gauge, 1.57 Lbs./SF)	B1@.019	SF	2.14	.65	2.79
600S200-54 (16 gauge, 1.96 Lbs./SF)	B1@.021	SF	2.67	.72	3.39
600S200-68 (14 gauge, 2.42 Lbs./SF)	B1@.023	SF	3.29	.78	4.07
600S200-97 (12 gauge, 3.37 Lbs./SF)	B1@.025	SF	4.58	.85	5.43
6" steel floor joists 24" OC, 1-5/8" flange					
600S162-33 (20 gauge, .78 Lbs./SF)	B1@.013	SF	1.06	.44	1.50
600S162-43 (18 gauge, 1.01 Lbs./SF)	B1@.013	SF	1.37	.44	1.81
600S162-54 (16 gauge, 1.25 Lbs./SF)	B1@.014	SF	1.70	.48	2.18
600S162-68 (14 gauge, 1.55 Lbs./SF)	B1@.016	SF	2.11	.55	2.66
600S162-97 (12 gauge, 2.15 Lbs./SF)	B1@.018	SF	2.92	.61	3.53
6" steel floor joists 24" OC, 2" flange					
600S200-33 (20 gauge, .86 Lbs./SF)	B1@.013	SF	1.17	.44	1.61
600S200-43 (18 gauge, 1.11 Lbs./SF)	B1@.013	SF	1.51	.44	1.95
600S200-54 (16 gauge, 1.38 Lbs./SF)	B1@.014	SF	1.88	.48	2.36
600S200-68 (14 gauge, 1.71 Lbs./SF)	B1@.016	SF	2.33	.55	2.88
600S200-97 (12 gauge, 2.37 Lbs./SF)	B1@.018	SF	3.22	.61	3.83
8" steel floor joists 12" OC, 1-5/8" flange					
800S162-33 (20 gauge, 1.47 Lbs./SF)	B1@.025	SF	2.00	.85	2.85
800S162-43 (18 gauge, 2.24 Lbs./SF)	B1@.025	SF	3.05	.85	3.90
800S162-54 (16 gauge, 2.78 Lbs./SF)	B1@.028	SF	3.78	.96	4.74
800S162-68 (14 gauge, 3.44 Lbs./SF)	B1@.031	SF	4.68	1.06	5.74
800S162-97 (12 gauge, 4.79 Lbs./SF)	B1@.034	SF	6.51	1.16	7.67

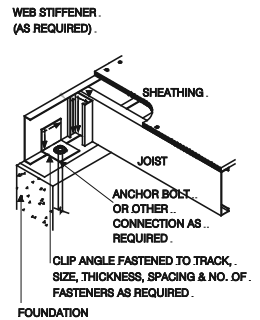

Carpentry, Steel Framing

	Craft@Hrs	Unit	Material	Labor	Total
8" steel floor joists 12" OC, 2" flange					
800S200-33 (20 gauge, 1.87 Lbs./SF)	B1@.025	SF	2.54	.85	3.39
800S200-43 (18 gauge, 2.42 Lbs./SF)	B1@.025	SF	3.29	.85	4.14
800S200-54 (16 gauge, 3.00 Lbs./SF)	B1@.028	SF	4.08	.96	5.04
800S200-68 (14 gauge, 3.74 Lbs./SF)	B1@.031	SF	5.09	1.06	6.15
800S200-97 (12 gauge, 5.20 Lbs./SF)	B1@.034	SF	7.07	1.16	8.23
8" steel floor joists 16" OC, 1-5/8" flange					
800S162-33 (20 gauge, 1.35 Lbs./SF)	B1@.020	SF	1.84	.68	2.52
800S162-43 (18 gauge, 1.73 Lbs./SF)	B1@.020	SF	2.35	.68	3.03
800S162-54 (16 gauge, 2.14 Lbs./SF)	B1@.022	SF	2.91	.75	3.66
800S162-68 (14 gauge, 2.66 Lbs./SF)	B1@.024	SF	3.62	.82	4.44
800S162-97 (12 gauge, 3.70 Lbs./SF)	B1@.026	SF	5.03	.89	5.92
8" steel floor joists 16" OC, 2" flange					
800S200-33 (20 gauge, 1.45 Lbs./SF)	B1@.020	SF	1.97	.68	2.65
800S200-43 (18 gauge, 1.87 Lbs./SF)	B1@.020	SF	2.54	.68	3.22
800S200-54 (16 gauge, 2.32 Lbs./SF)	B1@.022	SF	3.16	.75	3.91
800S200-68 (14 gauge, 2.89 Lbs./SF)	B1@.024	SF	3.93	.82	4.75
800S200-97 (12 gauge, 4.01 Lbs./SF)	B1@.026	SF	5.45	.89	6.34
8" steel floor joists 24" OC, 1-5/8" flange					
800S162-33 (20 gauge, .95 Lbs./SF)	B1@.014	SF	1.29	.48	1.77
800S162-43 (18 gauge, 1.22 Lbs./SF)	B1@.014	SF	1.66	.48	2.14
800S162-54 (16 gauge, 1.51 Lbs./SF)	B1@.016	SF	2.05	.55	2.60
800S162-68 (14 gauge, 1.87 Lbs./SF)	B1@.017	SF	2.54	.58	3.12
800S162-97 (12 gauge, 2.61 Lbs./SF)	B1@.019	SF	3.55	.65	4.20
8" steel floor joists 24" OC, 2" flange					
800S200-33 (20 gauge, 1.02 Lbs./SF)	B1@.014	SF	1.39	.48	1.87
800S200-43 (18 gauge, 1.32 Lbs./SF)	B1@.014	SF	1.80	.48	2.28
800S200-54 (16 gauge, 1.63 Lbs./SF)	B1@.016	SF	2.22	.55	2.77
800S200-68 (14 gauge, 2.03 Lbs./SF)	B1@.017	SF	2.76	.58	3.34
800S200-97 (12 gauge, 2.83 Lbs./SF)	B1@.019	SF	3.85	.65	4.50
10" steel floor joists 12" OC, 1-5/8" flange					
1000S162-43 (18 gauge, 2.62 Lbs./SF)	B1@.028	SF	3.56	.96	4.52
1000S162-54 (16 gauge, 3.24 Lbs./SF)	B1@.030	SF	4.41	1.02	5.43
1000S162-68 (14 gauge, 4.04 Lbs./SF)	B1@.033	SF	5.49	1.13	6.62
1000S162-97 (12 gauge, 5.63 Lbs./SF)	B1@.037	SF	7.66	1.26	8.92
10" steel floor joists 12" OC, 2" flange					
1000S200-43 (18 gauge, 2.81 Lbs./SF)	B1@.028	SF	3.82	.96	4.78
1000S200-54 (16 gauge, 3.48 Lbs./SF)	B1@.030	SF	4.73	1.02	5.75
1000S200-68 (14 gauge, 4.32 Lbs./SF)	B1@.033	SF	5.88	1.13	7.01
1000S200-97 (12 gauge, 6.05 Lbs./SF)	B1@.037	SF	8.23	1.26	9.49
10" steel floor joists 16" OC, 1-5/8" flange					
1000S162-43 (18 gauge, 2.02 Lbs./SF)	B1@.022	SF	2.75	.75	3.50
1000S162-54 (16 gauge, 2.50 Lbs./SF)	B1@.024	SF	3.40	.82	4.22
1000S162-68 (14 gauge, 3.12 Lbs./SF)	B1@.027	SF	4.24	.92	5.16
1000S162-97 (12 gauge, 4.35 Lbs./SF)	B1@.029	SF	5.92	.99	6.91
10" steel floor joists 16" OC, 2" flange					
1000S200-43 (18 gauge, 2.17 Lbs./SF)	B1@.022	SF	2.95	.75	3.70
1000S200-54 (16 gauge, 2.69 Lbs./SF)	B1@.024	SF	3.66	.82	4.48
1000S200-68 (14 gauge, 3.34 Lbs./SF)	B1@.027	SF	4.54	.92	5.46
1000S200-97 (12 gauge, 4.67 Lbs./SF)	B1@.029	SF	6.35	.99	7.34

Carpentry, Steel Framing

	Craft@Hrs	Unit	Material	Labor	Total
10" steel floor joists 24" OC, 1-5/8" flange					
1000S162-43 (18 gauge, 1.42 Lbs./SF)	B1@.015	SF	1.93	.51	2.44
1000S162-54 (16 gauge, 1.76 Lbs./SF)	B1@.017	SF	2.39	.58	2.97
1000S162-68 (14 gauge, 2.20 Lbs./SF)	B1@.019	SF	2.99	.65	3.64
1000S162-97 (12 gauge, 3.06 Lbs./SF)	B1@.020	SF	4.16	.68	4.84
10" steel floor joists 24" OC, 2" flange					
1000S200-43 (18 gauge, 1.52 Lbs./SF)	B1@.015	SF	2.07	.51	2.58
1000S200-54 (16 gauge, 1.89 Lbs./SF)	B1@.017	SF	2.57	.58	3.15
1000S200-68 (14 gauge, 2.35 Lbs./SF)	B1@.019	SF	3.20	.65	3.85
1000S200-97 (12 gauge, 3.29 Lbs./SF)	B1@.020	SF	4.47	.68	5.15
12" steel floor joists 12" OC, 1-5/8" flange					
1200S162-54 (16 gauge, 3.72 Lbs./SF)	B1@.029	SF	5.06	.99	6.05
1200S162-68 (14 gauge, 4.63 Lbs./SF)	B1@.032	SF	6.30	1.09	7.39
1200S162-97 (12 gauge, 6.47 Lbs./SF)	B1@.035	SF	8.80	1.19	9.99
12" steel floor joists 12" OC, 2" flange					
1200S200-54 (16 gauge, 3.95 Lbs./SF)	B1@.029	SF	5.37	.99	6.36
1200S200-68 (14 gauge, 4.92 Lbs./SF)	B1@.032	SF	6.69	1.09	7.78
1200S200-97 (12 gauge, 6.88 Lbs./SF)	B1@.035	SF	9.36	1.19	10.55
12" steel floor joists 16" OC, 1-5/8" flange					
1200S162-54 (16 gauge, 2.88 Lbs./SF)	B1@.023	SF	3.92	.78	4.70
1200S162-68 (14 gauge, 3.57 Lbs./SF)	B1@.025	SF	4.86	.85	5.71
1200S162-97 (12 gauge, 4.99 Lbs./SF)	B1@.028	SF	6.79	.96	7.75
12" steel floor joists 16" OC, 2" flange					
1200S200-54 (16 gauge, 3.05 Lbs./SF)	B1@.023	SF	4.15	.78	4.93
1200S200-68 (14 gauge, 3.80 Lbs./SF)	B1@.025	SF	5.17	.85	6.02
1200S200-97 (12 gauge, 5.31 Lbs./SF)	B1@.028	SF	7.22	.96	8.18
12" steel floor joists 24" OC, 1-5/8" flange					
1200S162-54 (16 gauge, 2.03 Lbs./SF)	B1@.017	SF	2.76	.58	3.34
1200S162-68 (14 gauge, 2.52 Lbs./SF)	B1@.018	SF	3.43	.61	4.04
1200S162-97 (12 gauge, 3.52 Lbs./SF)	B1@.020	SF	4.79	.68	5.47
12" steel floor joists 24" OC, 2" flange					
1200S200-54 (16 gauge, 2.15 Lbs./SF)	B1@.017	SF	2.92	.58	3.50
1200S200-68 (14 gauge, 2.68 Lbs./SF)	B1@.018	SF	3.64	.61	4.25
1200S200-97 (12 gauge, 3.75 Lbs./SF)	B1@.020	SF	5.10	.68	5.78

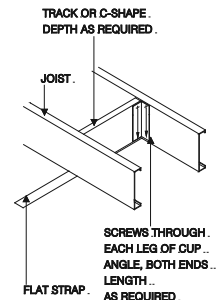

Built-up steel support beams and girders

Box or back-to-back beams made from 1-5/8" flange C-shaped sections. Includes typical fasteners and minimal waste.

Using built-up steel sections at	—	Lb	1.36	—	1.36
6" beams and girders built-up from two members					
2-600S162-43 (18 gauge, 3.04 Lbs./LF)	B1@.037	LF	4.16	1.26	5.42
2-600S162-54 (16 gauge, 3.78 Lbs./LF)	B1@.038	LF	5.14	1.30	6.44
2-600S162-68 (14 gauge, 4.72 Lbs./LF)	B1@.039	LF	6.42	1.33	7.75
2-600S162-97 (12 gauge, 6.58 Lbs./LF)	B1@.041	LF	8.95	1.40	10.35
8" beams and girders built-up from two members					
2-800S162-43 (18 gauge, 3.66 Lbs./LF)	B1@.049	LF	4.98	1.67	6.65
2-800S162-54 (16 gauge, 4.56 Lbs./LF)	B1@.050	LF	6.20	1.71	7.91
2-800S162-68 (14 gauge, 5.68 Lbs./LF)	B1@.051	LF	7.72	1.74	9.46
2-800S162-97 (12 gauge, 7.96 Lbs./LF)	B1@.053	LF	10.80	1.81	12.61

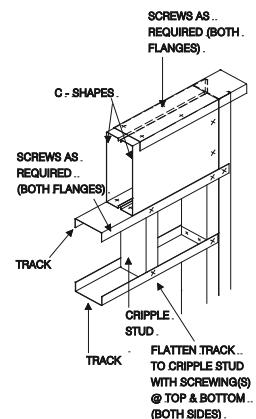

Carpentry, Steel Framing

	Craft@Hrs	Unit	Material	Labor	Total
10" beams and girders built-up from two members					
2-1000S162-43 (18 gauge, 4.26 Lbs./LF)	B1@.063	LF	5.79	2.15	7.94
2-1000S162-54 (16 gauge, 5.23 Lbs./LF)	B1@.064	LF	7.24	2.18	9.42
2-1000S162-68 (14 gauge, 6.66 Lbs./LF)	B1@.065	LF	9.06	2.22	11.28
2-1000S162-97 (12 gauge, 9.34 Lbs./LF)	B1@.069	LF	12.70	2.35	15.05
12" beams and girders built-up from two members					
2-1200S162-54 (16 gauge, 6.10 Lbs./LF)	B1@.073	LF	8.30	2.49	10.79
2-1200S162-68 (14 gauge, 7.62 Lbs./LF)	B1@.075	LF	10.40	2.56	12.96
2-1200S162-97 (12 gauge, 10.72 Lbs./LF)	B1@.079	LF	14.60	2.69	17.29

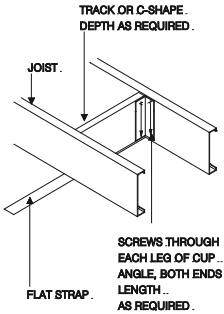

Steel joist solid blocking Installed between 6" thru 12" joists. 18 gauge, C-shape, with angle. Including typical screws, stiffeners and minimal waste.

Using light-gauge steel framing materials at

	—	Lb	1.36	—	1.36
Blocking for 6" steel joists					
Joists on 12" centers	B1@.042	Ea	2.23	1.43	3.66
Joists on 16" centers	B1@.042	Ea	2.96	1.43	4.39
Joists on 20" centers	B1@.042	Ea	3.75	1.43	5.18
Joists on 24" centers	B1@.042	Ea	4.49	1.43	5.92
Blocking for 8" steel joists					
Joists on 12" centers	B1@.050	Ea	3.37	1.71	5.08
Joists on 16" centers	B1@.050	Ea	4.49	1.71	6.20
Joists on 20" centers	B1@.050	Ea	5.60	1.71	7.31
Joists on 24" centers	B1@.050	Ea	6.72	1.71	8.43
Blocking for 10" steel joists					
Joists on 12" centers	B1@.057	Ea	3.92	1.94	5.86
Joists on 16" centers	B1@.057	Ea	5.24	1.94	7.18
Joists on 20" centers	B1@.057	Ea	6.56	1.94	8.50
Joists on 24" centers	B1@.057	Ea	7.79	1.94	9.73
Blocking for 12" steel joists					
Joists on 12" centers	B1@.064	Ea	4.53	2.18	6.71
Joists on 16" centers	B1@.064	Ea	6.01	2.18	8.19
Joists on 20" centers	B1@.064	Ea	7.51	2.18	9.69
Joists on 24" centers	B1@.064	Ea	8.99	2.18	11.17

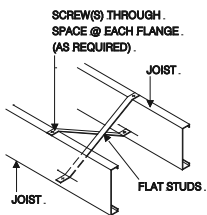

Steel cross bridging for steel floor joists Using strap material or manufactured straps installed between 6" thru 12" joists, cost per pair of straps including typical fasteners.

Joists on 12" centers	B1@.025	Pr	6.08	.85	6.93
Joists on 16" centers	B1@.025	Pr	6.27	.85	7.12
Joists on 20" centers	B1@.025	Pr	6.39	.85	7.24
Joists on 24" centers	B1@.025	Pr	6.57	.85	7.42

Board sheathing subfloor 1" x 6" #3 & Btr (1.28 BF per SF), screwed or pinned to steel floor joists, including fasteners.

Board sheathing, per MBF	—	MBF	3,750.00	—	3,750.00
With 12% shrinkage, 5% waste & screws	B1@.022	SF	4.43	.75	5.18
Add for diagonal patterns	B1@.001	SF	.44	.03	.47

Plywood subfloor CD standard exterior grade. Material costs shown include 5% for waste, screwed or pinned to steel floor joists, including fasteners

3/8"	B1@.012	SF	.93	.41	1.34
1/2"	B1@.013	SF	1.63	.44	2.07
5/8"	B1@.013	SF	1.58	.44	2.02
3/4"	B1@.014	SF	1.60	.48	2.08

Carpentry, Steel Framing

	Craft@Hrs	Unit	Material	Labor	Total
OSB sheathing, Material costs shown include 5% for waste & fasteners					
7/16"	B1@.011	SF	1.11	.38	1.49
1/2"	B1@.012	SF	1.48	.41	1.89
5/8"	B1@.012	SF	1.72	.41	2.13
3/4" tongue and groove	B1@.014	SF	1.99	.48	2.47
Steel interior wall studs Per square foot of partition wall area measured one side. Do not subtract for openings less than 16' wide. Costs include studs, top and bottom track, screws and splices. Add for each corner or wall junction as indicated below. Add the cost of wood plates (if used), support beams, door opening framing and corners from below. All studs with 1-1/4" flange are assumed to have a 3/16" stiffening lip. Labor includes layout, assembly, plumb and align. Figures in parentheses show weight of steel per square foot of wall measured one side. Assumes minimal waste. See the following section for exterior wall estimates.					
Using light-gauge steel framing materials at	—	Lb	1.36	—	1.36
2-1/2" steel interior wall framing, 16" OC, 1-1/4" flange					
250S125-18 (25 gauge, .33 Lbs./SF)	B1@.018	SF	.45	.61	1.06
250S125-27 (22 gauge, .49 Lbs./ SF)	B1@.018	SF	.67	.61	1.28
250S125-30 (20DW gauge, .54 Lbs./SF)	B1@.019	SF	.74	.65	1.39
250S125-33 (20 gauge, .60 Lbs./SF)	B1@.020	SF	.81	.68	1.49
2-1/2" steel interior wall framing, 24" OC, 1-1/4" flange					
250S125-18 (25 gauge, .25 Lbs./SF)	B1@.017	SF	.35	.58	.93
250S125-27 (22 gauge, .37 Lbs./SF)	B1@.017	SF	.50	.58	1.08
250S125-30 (20DW gauge, .41 Lbs./SF)	B1@.018	SF	.56	.61	1.17
250S125-33 (20 gauge, .45 Lbs./SF)	B1@.019	SF	.61	.65	1.26
Add for each 2-1/2" corner or wall junction	B1@.091	Ea	6.14	3.10	9.24
3-1/2" steel interior wall framing, 16" OC, 1-1/4" flange					
350S125-18 (25 gauge, .39 Lbs./SF)	B1@.023	SF	.54	.78	1.32
350S125-27 (22 gauge, .59 Lbs./SF)	B1@.023	SF	.80	.78	1.58
350S125-30 (20DW gauge, .65 Lbs./SF)	B1@.024	SF	.88	.82	1.70
350S125-33 (20 gauge, .72 Lbs./SF)	B1@.025	SF	.98	.85	1.83
3-1/2" steel interior wall framing, 24" OC, 1-1/4" flange					
350S125-18 (25 gauge, .29 Lbs./SF)	B1@.020	SF	.39	.68	1.07
350S125-27 (22 gauge, .44 Lbs./SF)	B1@.020	SF	.60	.68	1.28
350S125-30 (20DW gauge, .49 Lbs./SF)	B1@.022	SF	.67	.75	1.42
350S125-33 (20 gauge, .54 Lbs./SF)	B1@.023	SF	.74	.78	1.52
Add for each 3-1/2" corner or wall junction	B1@.091	Ea	6.55	3.10	9.65
3-5/8" steel interior wall framing, 16" OC, 1-1/4" flange					
362S125-18 (25 gauge, .40 Lbs./SF)	B1@.023	SF	.55	.78	1.33
362S125-27 (22 gauge, .60 Lbs./SF)	B1@.023	SF	.81	.78	1.59
362S125-30 (20DW gauge, .66 Lbs./SF)	B1@.024	SF	.89	.82	1.71
362S125-33 (20 gauge, .73 Lbs./SF)	B1@.025	SF	.99	.85	1.84
3-5/8" steel interior wall framing, 24" OC, 1-1/4" flange					
362S125-18 (25 gauge, .30 Lbs./SF)	B1@.021	SF	.41	.72	1.13
362S125-27 (22 gauge, .45 Lbs./SF)	B1@.021	SF	.61	.72	1.33
362S125-30 (20DW gauge, .50 Lbs./SF)	B1@.022	SF	.68	.75	1.43
362S125-33 (20 gauge, .55 Lbs./SF)	B1@.023	SF	.75	.78	1.53
Add for each 3-5/8" corner or wall junction	B1@.091	Ea	6.55	3.10	9.65

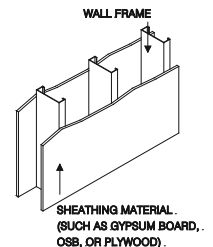

Carpentry, Steel Framing

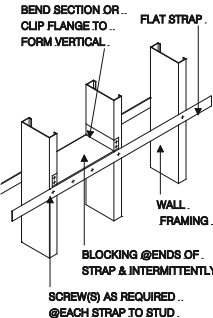
	Craft@Hrs	Unit	Material	Labor	Total
5-1/2" steel interior wall framing, 16" OC, 1-1/4" flange					
550S125-18 (25 gauge, .52 Lbs./SF)	B1@.029	SF	.70	.99	1.69
550S125-27 (22 gauge, .78 Lbs./SF)	B1@.029	SF	1.06	.99	2.05
550S125-30 (20DW gauge, .86 Lbs./SF)	B1@.030	SF	1.17	1.02	2.19
550S125-33 (20 gauge, .95 Lbs./SF)	B1@.032	SF	1.29	1.09	2.38
5-1/2" steel interior wall framing, 24" OC, 1-1/4" flange					
550S125-18 (25 gauge, .39 Lbs./SF)	B1@.028	SF	.54	.96	1.50
550S125-27 (22 gauge, .59 Lbs./SF)	B1@.028	SF	.80	.96	1.76
550S125-30 (20DW gauge, .65 Lbs./SF)	B1@.029	SF	.88	.99	1.87
550S125-33 (20 gauge, .71 Lbs./SF)	B1@.030	SF	.97	1.02	1.99
Add for each 5-1/2" corner or wall junction	B1@.091	Ea	8.57	3.10	11.67
6" steel interior wall framing, 16" OC, 1-1/4" flange					
600S125-18 (25 gauge, .55 Lbs./SF)	B1@.028	SF	.75	.96	1.71
600S125-27 (22 gauge, .83 Lbs./SF)	B1@.029	SF	1.13	.99	2.12
600S125-30 (20DW gauge), .91 Lbs./SF	B1@.030	SF	1.24	1.02	2.26
600S125-33 (20 gauge, 1.01 Lbs./SF)	B1@.032	SF	1.37	1.09	2.46
6" steel interior wall framing, 24" OC, 1-1/4" flange					
600S125-18 (25 gauge, .41 Lbs./SF)	B1@.027	SF	.56	.92	1.48
600S125-27 (22 gauge, .62 Lbs./SF)	B1@.027	SF	.85	.92	1.77
600S125-30 (20DW gauge, .68 Lbs./SF)	B1@.028	SF	.93	.96	1.89
600S125-33 (20 gauge, .76 Lbs./SF)	B1@.030	SF	1.04	1.02	2.06
Add for each 6" corner or wall junction	B1@.091	Ea	9.14	3.10	12.24
 <p>Steel exterior wall studs Per square foot of wall area measured one side. Do not subtract for openings less than 16' wide. Add for each corner and partition from below. Costs include studs, top and bottom track, screws and splices. Add for door and window opening framing, backing, cross-bracing and sheathing for shear walls from the sections that follow. Add the cost of wood plates (if used), support beams, door opening framing, corners and wall junctions from below. All studs with 1-5/8" flange are assumed to have a 1/2" stiffening lip. Labor includes layout, assembly, plumb and align. Figures in parentheses show weight of steel per square foot of wall measured one side. Assumes minimal waste. See the previous section for interior (partition) wall estimates.</p>					
Using light-gauge steel framing materials at	—	Lb	1.36	—	1.36
3-1/2" steel exterior wall framing, 12" OC, 1-5/8" flange					
350S162-33 (20 gauge, 1.10 Lbs./SF)	B1@.026	SF	1.50	.89	2.39
350S162-43 (18 gauge, 1.43 Lbs./SF)	B1@.026	SF	1.94	.89	2.83
350S162-54 (16 gauge, 1.76 Lbs./SF)	B1@.028	SF	2.40	.96	3.36
350S162-68 (14 gauge, 2.19 Lbs./SF)	B1@.029	SF	2.98	.99	3.97
3-1/2" steel exterior wall framing, 16" OC, 1-5/8" flange					
350S162-33 (20 gauge, .88 Lbs./SF)	B1@.025	SF	1.19	.85	2.04
350S162-43 (18 gauge, 1.14 Lbs./SF)	B1@.025	SF	1.55	.85	2.40
350S162-54 (16 gauge, 1.41 Lbs./SF)	B1@.028	SF	1.92	.96	2.88
350S162-68 (14 gauge, 1.75 Lbs./SF)	B1@.029	SF	2.39	.99	3.38
3-1/2" steel exterior wall framing, 24" OC, 1-5/8" flange					
350S162-33 (20 gauge, .66 Lbs./SF)	B1@.023	SF	.89	.78	1.67
350S162-43 (18 gauge, .86 Lbs./SF)	B1@.023	SF	1.17	.78	1.95
350S162-54 (16 gauge, 1.06 Lbs./SF)	B1@.025	SF	1.44	.85	2.29
350S162-68 (14 gauge, 1.31 Lbs./SF)	B1@.026	SF	1.79	.89	2.68
Add for each 3-1/2" corner or partition (33 mil)	B1@.091	Ea	8.04	3.10	11.14

Carpentry, Steel Framing

	Craft@Hrs	Unit	Material	Labor	Total
3-5/8" steel exterior wall framing, 12" OC, 1-5/8" flange					
362S162-33 (20 gauge, 1.11 Lbs./SF)	B1@.026	SF	1.52	.89	2.41
362S162-43 (18 gauge, 1.45 Lbs./SF)	B1@.026	SF	1.97	.89	2.86
362S162-54 (16 gauge, 1.80 Lbs./SF)	B1@.028	SF	2.45	.96	3.41
362S162-68 (14 gauge, 2.23 Lbs./SF)	B1@.029	SF	3.04	.99	4.03
3-5/8" steel exterior wall framing, 16" OC, 1-5/8" flange					
362S162-33 (20 gauge, .89 Lbs./SF)	B1@.025	SF	1.22	.85	2.07
362S162-43 (18 gauge, 1.16 Lbs./SF)	B1@.025	SF	1.57	.85	2.42
362S162-54 (16 gauge, 1.44 Lbs./SF)	B1@.028	SF	1.96	.96	2.92
362S162-68 (14 gauge, 1.78 Lbs./SF)	B1@.029	SF	2.42	.99	3.41
3-5/8" steel exterior wall framing, 24" OC, 1-5/8" flange					
362S162-33 (20 gauge, .67 Lbs./SF)	B1@.023	SF	.91	.78	1.69
362S162-43 (18 gauge, .87 Lbs./SF)	B1@.023	SF	1.18	.78	1.96
362S162-54 (16 gauge, 1.08 Lbs./SF)	B1@.025	SF	1.47	.85	2.32
362S162-68 (14 gauge, 1.34 Lbs./SF)	B1@.026	SF	1.83	.89	2.72
Add for each 3-5/8" corner or partition (33 mil)	B1@.091	Ea	8.26	3.10	11.36
5-1/2" steel exterior wall framing, 12" OC, 1-5/8" flange					
550S162-33 (20 gauge, 1.39 Lbs./SF)	B1@.035	SF	1.90	1.19	3.09
550S162-43 (18 gauge, 1.80 Lbs./SF)	B1@.036	SF	2.45	1.23	3.68
550S162-54 (16 gauge, 2.25 Lbs./SF)	B1@.039	SF	3.07	1.33	4.40
550S162-68 (14 gauge, 2.80 Lbs./SF)	B1@.041	SF	3.82	1.40	5.22
5-1/2" steel exterior wall framing, 16" OC, 1-5/8" flange					
550S162-33 (20 gauge, 1.11 Lbs./SF)	B1@.032	SF	1.52	1.09	2.61
550S162-43 (18 gauge, 1.44 Lbs./SF)	B1@.033	SF	1.96	1.13	3.09
550S162-54 (16 gauge, 1.80 Lbs./SF)	B1@.035	SF	2.45	1.19	3.64
550S162-68 (14 gauge, 2.24 Lbs./SF)	B1@.037	SF	3.05	1.26	4.31
5-1/2" steel exterior wall framing, 20" OC, 1-5/8" flange					
550S162-33 (20 gauge, .94 Lbs./SF)	B1@.031	SF	1.28	1.06	2.34
550S162-43 (18 gauge, 1.22 Lbs./SF)	B1@.032	SF	1.66	1.09	2.75
550S162-54 (16 gauge, 1.53 Lbs./SF)	B1@.034	SF	2.09	1.16	3.25
550S162-68 (14 gauge, 1.90 Lbs./SF)	B1@.036	SF	2.59	1.23	3.82
5-1/2" steel exterior wall framing, 24" OC, 1-5/8" flange					
550S162-33 (20 gauge, .83 Lbs./SF)	B1@.030	SF	1.13	1.02	2.15
550S162-43 (18 gauge, 1.08 Lbs./SF)	B1@.031	SF	1.47	1.06	2.53
550S162-54 (16 gauge, 1.35 Lbs./SF)	B1@.033	SF	1.84	1.13	2.97
550S162-68 (14 gauge, 1.68 Lbs./SF)	B1@.035	SF	2.29	1.19	3.48
Add for each 5-1/2" corner or partition (43 mil)	B1@.091	Ea	10.20	3.10	13.30
6" steel exterior wall framing, 12" OC, 1-5/8" flange					
600S162-33 (20 gauge, 1.46 Lbs./SF)	B1@.035	SF	1.99	1.19	3.18
600S162-43 (18 gauge, 1.90 Lbs./SF)	B1@.036	SF	2.59	1.23	3.82
600S162-54 (16 gauge, 2.36 Lbs./SF)	B1@.039	SF	3.21	1.33	4.54
600S162-68 (14 gauge, 2.95 Lbs./SF)	B1@.041	SF	4.02	1.40	5.42
600S162-97 (12 gauge, 4.11 Lbs./SF)	B1@.043	SF	5.60	1.47	7.07
6" steel exterior wall framing, 16" OC, 1-5/8" flange					
600S162-33 (20 gauge, 1.17 Lbs./SF)	B1@.032	SF	1.60	1.09	2.69
600S162-43 (18 gauge, 1.52 Lbs./SF)	B1@.033	SF	2.06	1.13	3.19
600S162-54 (16 gauge, 1.89 Lbs./SF)	B1@.035	SF	2.58	1.19	3.77
600S162-68 (14 gauge, 2.36 Lbs./SF)	B1@.037	SF	3.21	1.26	4.47
600S162-97 (12 gauge, 3.29 Lbs./SF)	B1@.039	SF	4.47	1.33	5.80

Carpentry, Steel Framing

	Craft@Hrs	Unit	Material	Labor	Total
6" steel exterior wall framing, 20" OC, 1-5/8" flange					
600S162-33 (20 gauge, .99 Lbs./SF)	B1@.031	SF	1.35	1.06	2.41
600S162-43 (18 gauge, 1.29 Lbs./SF)	B1@.032	SF	1.75	1.09	2.84
600S162-54 (16 gauge, 1.60 Lbs./SF)	B1@.034	SF	2.18	1.16	3.34
600S162-68 (14 gauge, 2.00 Lbs./SF)	B1@.036	SF	2.72	1.23	3.95
600S162-97 (12 gauge), 2.79 Lbs./SF	B1@.038	SF	3.79	1.30	5.09
6" steel exterior wall framing, 24" OC, 1-5/8" flange					
600S162-33 (20 gauge, .88 Lbs./SF)	B1@.030	SF	1.20	1.02	2.22
600S162-43 (18 gauge, 1.14 Lbs./SF)	B1@.031	SF	1.55	1.06	2.61
600S162-54 (16 gauge, 1.42 Lbs./SF)	B1@.033	SF	1.93	1.13	3.06
600S162-68 (14 gauge, 1.77 Lbs./SF)	B1@.035	SF	2.41	1.19	3.60
600S162-97 (12 gauge, 2.47 Lbs./SF)	B1@.037	SF	3.36	1.26	4.62
Add for each 6" corner or partition (43 mil)	B1@.091	Ea	10.70	3.10	13.80
8" steel exterior wall framing, 16" OC, 1-5/8" flange					
18 gauge	B1@.044	SF	3.17	1.50	4.67
16 gauge	B1@.046	SF	3.54	1.57	5.11

Door opening steel framing In wall studs, based on walls 8' high. Costs shown are per each door opening and include header of appropriate size, double king studs each side of the opening for doors greater than 3' wide, double trimmer studs each side of the opening for doors greater than 8' wide, cripples, blocking, screws and normal waste. Width shown is size of finished opening. Figures in parentheses indicate header size.

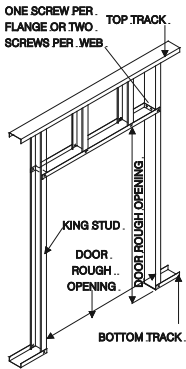

Using wall studs and headers, per Lb	—	Lb	1.36	—	1.36
Door opening steel framing in 3-1/2" wall, 20 gauge (33 mil) stud wall, opening size as shown					
To 3' wide, 6" header, 18 gauge, two 600S162-43, 40.05 Lbs	B1@1.00	Ea	54.50	34.10	88.60
Over 3' to 4' wide, 6" header, 16 gauge, two 600S162-54, 56.48 Lbs	B1@1.33	Ea	76.90	45.40	122.30
Over 4' to 5' wide, 8" header, 16 gauge, two 800S162-54, 63.85 Lbs	B1@1.67	Ea	87.00	57.00	144.00
Over 5' to 6' wide, 8" header, 16 gauge, two 800S162-54, 68.43 Lbs	B1@1.99	Ea	93.20	67.90	161.10
Over 6' to 8' wide, 10" header, 14 gauge, two 1000S162-68, 107.25 Lbs	B1@2.33	Ea	146.00	79.50	225.50
Over 8' to 10' wide, 12" header, 14 gauge, two 1200S162-68, 130.15 Lbs	B1@2.33	Ea	178.00	79.50	257.50
Over 10' to 12' wide, 12" header, 12 gauge, two 1200S162-97, 182.60 Lbs	B1@2.67	Ea	248.00	91.10	339.10
Add per foot of height for 3-1/2" walls over 8' in height	—	LF	7.84	—	7.84
Door opening steel framing in 5-1/2" wall, 18 gauge (43 mil) stud wall, opening size as shown					
To 3' wide, 6" header, 18 gauge, two 600S162-43, 53.75 Lbs	B1@1.00	Ea	73.10	34.10	107.20
Over 3' to 4' wide, 6" header, 16 gauge, two 600S162-54, 82.80 Lbs	B1@1.33	Ea	113.00	45.40	158.40
Over 4' to 5' wide, 8" header, 16 gauge, two 800S162-54, 90.00 Lbs	B1@1.67	Ea	123.00	57.00	180.00
Over 5' to 6' wide, 8" header, 16 gauge, two 800S162-54, 94.55 Lbs	B1@1.99	Ea	129.00	67.90	196.90
Over 6' to 8' wide, 10" header, 14 gauge, two 1000S162-68, 120.00 Lbs	B1@2.33	Ea	163.00	79.50	242.50
Over 8' to 10' wide, 12" header, 14 gauge, two 1200S162-68, 162.60 Lbs	B1@2.33	Ea	222.00	79.50	301.50

Carpentry, Steel Framing

	Craft@Hrs	Unit	Material	Labor	Total
Over 10' to 12' wide, 12" header, 12 gauge, two 1200S162-97, 215.05 Lbs	B1@2.67	Ea	292.00	91.10	383.10
Add per foot of height for 5-1/2" walls over 8' in height	—	LF	12.80	—	12.80

Window opening steel framing In wall studs, based on walls 8' high. Costs shown are per window opening and include header of appropriate size, sill track, double king studs each side of the opening for windows greater than 3' wide, double trimmer studs each side of the opening for windows greater than 8' wide, top and bottom cripples, blocking, screws and normal waste. Width shown is size of finished opening.

Using steel framing materials at — Lb 1.36 — 1.36

Window opening steel framing in 3-1/2" wall, 20 gauge (33 mil) stud wall, opening size shown

To 2' wide, 4" header, 18 gauge, two 400S162-43, 35.18 Lbs	B1@1.20	Ea	48.00	40.90	88.90
Over 2' to 3' wide, 6" header, 18 gauge, two 600S162-43, 40.48 Lbs	B1@1.40	Ea	55.10	47.80	102.90
Over 3' to 4' wide, 6" header, 16 gauge, two 600S162-54, 61.85 Lbs	B1@1.74	Ea	84.20	59.40	143.60
Over 4' to 5' wide, 8" header, 16 gauge, two 800S162-54, 71.45 Lbs	B1@2.08	Ea	97.30	70.90	168.20
Over 5' to 6' wide, 8" header, 16 gauge, two 800S162-54, 77.55 Lbs	B1@2.41	Ea	106.00	82.20	188.20
Over 6' to 7' wide, 8" header, 14 gauge, two 800S162-68, 91.45 Lbs	B1@2.75	Ea	124.00	93.80	217.80
Over 7' to 8' wide, 10" header, 14 gauge, two 1000S162-68, 106.23 Lbs	B1@3.08	Ea	144.00	105.00	249.00
Over 8' to 10' wide, 12" header, 14 gauge, two 1200S162-68, 144.20 Lbs	B1@3.08	Ea	197.00	105.00	302.00
Over 10' to 12' wide, 12" header, 12 gauge, two 1200S162-97, 199.68 Lbs	B1@3.42	Ea	272.00	117.00	389.00
Add per foot of height for 3-1/2" walls over 8' high	—	LF	7.84	—	7.84

Window opening steel framing in 5-1/2" wall, 18 gauge, 43 mil stud wall, opening size as shown

To 2' wide, 4" header, 18 gauge, two 400S162-43, 55.00 Lbs	B1@1.20	Ea	74.90	40.90	115.80
Over 2' to 3' wide, 6" header, 18 gauge, two 600S162-43, 61.18 Lbs	B1@1.40	Ea	83.30	47.80	131.10
Over 3' to 4' wide, 6" header, 16 gauge, two 600S162-54, 92.62 Lbs	B1@1.74	Ea	126.00	59.40	185.40
Over 4' to 5' wide, 8" header, 16 gauge, two 800S162-54, 103.15 Lbs	B1@2.08	Ea	141.00	70.90	211.90
Over 5' to 6' wide, 8" header, 16 gauge, two 800S162-54, 110.30 Lbs	B1@2.41	Ea	150.00	82.20	232.20
Over 6' to 8' wide, 10" header, 14 gauge, two 1000S162-68, 140.95 Lbs	B1@3.08	Ea	192.00	105.00	297.00
Over 8' to 10' wide, 12" header, 14 gauge, two 1200S162-68, 188.78 Lbs	B1@3.08	Ea	256.00	105.00	361.00
Over 8' to 12' wide, 12" header, 12 gauge, two 1200S162-97, 246.43 Lbs	B1@3.42	Ea	335.00	117.00	452.00
Add per foot of height for 5-1/2" walls over 8' high	—	LF	12.80	—	12.80

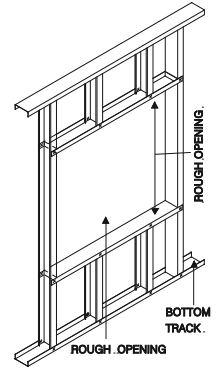

Carpentry, Steel Framing

Craft@Hrs Unit Material Labor Total

Steel wall bracing See also sheathing for plywood bracing and shear panels.

Steel strap bracing

4" wide 33 mil with gusset plates	B1@.015	LF	.50	.51	1.01
4" wide 43 mil with gusset plates	B1@.015	LF	.66	.51	1.17
8.8" wide 33 mil	B1@.015	LF	1.03	.51	1.54
8.8" wide 43 mil	B1@.015	LF	1.34	.51	1.85
8.8" wide 54 mil	B1@.015	LF	1.69	.51	2.20

Intermediate bracing 3-1/2", 33 mil studs or track

350S162-33 (0.80 Lbs./LF)	B1@.019	LF	1.26	.65	1.91
----------------------------	---------	----	------	-----	------

Temporary wood bracing for walls, assumes salvage at 50% and 3 uses

1" x 4" Std & Btr	B1@.006	LF	.24	.20	.44
1" x 6" Std & Btr	B1@.010	LF	.41	.34	.75
2" x 4" utility	B1@.012	LF	.21	.41	.62
2" x 6" utility	B1@.018	LF	.31	.61	.92

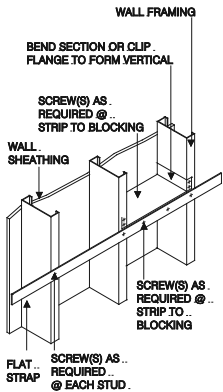

Wood wall plates Std & Btr, untreated. For pressure treated plates, see Wood sill plates for steel framing previously in this section. Figures in parentheses indicate board feet per LF. Costs shown include 10% waste.

2" x 3" wall plates, per MBF	—	MBF	1,390.00	—	1,390.00
2" x 4" wall plates, per MBF	—	MBF	1,240.00	—	1,240.00
2" x 6" wall plates, per MBF	—	MBF	1,260.00	—	1,260.00
2" x 8" wall plates, per MBF	—	MBF	1,110.00	—	1,110.00
2" x 3" (.55 BF per LF)	B1@.010	LF	.84	.34	1.18
2" x 4" (.73 BF per LF)	B1@.012	LF	.99	.41	1.40
2" x 6" (1.10 BF per LF)	B1@.018	LF	1.52	.61	2.13
2" x 8" (1.10 BF per LF)	B1@.018	LF	1.70	.61	2.31

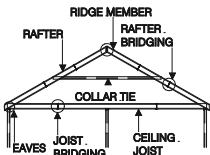

Steel ceiling joists and soffits Per SF of area covered. Including typical stiffeners, splices, bracing, rim joists and screws. Add the cost of beams, bridging, blocking, ledger strips and trimmers as required. See costs for beams, bridging, backing, blocking and trimmers elsewhere in this section. Deduct for openings over 25 SF. Labor includes layout, assembly and alignment. Figures in parentheses show weight of steel per square foot of ceiling. Assumes minimal waste.

Using light-gauge steel framing materials at	—	Lb	1.36	—	1.36
3-1/2" steel ceiling joists, 16" OC, 1-5/8" flange					
350S162-33 (20 gauge, .88 Lbs./SF)	B1@.022	SF	1.19	.75	1.94
350S162-43 (18 gauge), 1.11 Lbs./SF	B1@.024	SF	1.52	.82	2.34
350S162-54 (16 gauge, 1.35 Lbs./SF)	B1@.027	SF	1.84	.92	2.76
350S162-68 (14 gauge, 1.65 Lbs./SF)	B1@.029	SF	2.24	.99	3.23
3-1/2" steel ceiling joists, 24" OC, 1-5/8" flange					
350S162-33 (20 gauge, .63 Lbs./SF)	B1@.015	SF	.86	.51	1.37
350S162-43 (18 gauge, .79 Lbs./SF)	B1@.017	SF	1.07	.58	1.65
350S162-54 (16 gauge, .96 Lbs./SF)	B1@.019	SF	1.31	.65	1.96
350S162-68 (14 gauge, 1.17 Lbs./SF)	B1@.020	SF	1.60	.68	2.28
4" steel ceiling joists, 16" OC, 1-5/8" flange					
400S162-33 (20 gauge, .93 Lbs./SF)	B1@.022	SF	1.26	.75	2.01
400S162-43 (18 gauge), 1.17 Lbs./SF	B1@.024	SF	1.60	.82	2.42
400S162-54 (16 gauge, 1.44 Lbs./SF)	B1@.027	SF	1.96	.92	2.88
400S162-68 (14 gauge, 1.76 Lbs./SF)	B1@.029	SF	2.40	.99	3.39

Carpentry, Steel Framing

	Craft@Hrs	Unit	Material	Labor	Total
4" steel ceiling joists, 24" OC, 1-5/8" flange					
400S162-33 (20 gauge, .67 Lbs./SF)	B1@.015	SF	.91	.51	1.42
400S162-43 (18 gauge, .84 Lbs./SF)	B1@.017	SF	1.15	.58	1.73
400S162-54 (16 gauge, 1.02 Lbs./SF)	B1@.019	SF	1.38	.65	2.03
400S162-68 (14 gauge, 1.25 Lbs./SF)	B1@.020	SF	1.71	.68	2.39
5-1/2" steel ceiling joists, 12" OC, 1-5/8" flange					
550S162-33 (20 gauge, 1.41 Lbs./SF)	B1@.029	SF	1.92	.99	2.91
550S162-43 (18 gauge, 1.79 Lbs./SF)	B1@.032	SF	2.43	1.09	3.52
550S162-54 (16 gauge, 2.21 Lbs./SF)	B1@.035	SF	3.01	1.19	4.20
550S162-68 (14 gauge, 2.72 Lbs./SF)	B1@.038	SF	3.70	1.30	5.00
5-1/2" steel ceiling joists, 16" OC, 1-5/8" flange					
550S162-33 (20 gauge, 1.09 Lbs./SF)	B1@.022	SF	1.48	.75	2.23
550S162-43 (18 gauge, 1.39 Lbs./SF)	B1@.024	SF	1.90	.82	2.72
550S162-54 (16 gauge, 1.71 Lbs./SF)	B1@.027	SF	2.33	.92	3.25
550S162-68 (14 gauge, 2.10 Lbs./SF)	B1@.029	SF	2.86	.99	3.85
5-1/2" steel ceiling joists, 24" OC, 1-5/8" flange					
550S162-33 (20 gauge, .78 Lbs./SF)	B1@.016	SF	1.06	.55	1.61
550S162-43 (18 gauge, .99 Lbs./SF)	B1@.018	SF	1.35	.61	1.96
550S162-54 (16 gauge, 1.21 Lbs./SF)	B1@.020	SF	1.65	.68	2.33
550S162-68 (14 gauge, 1.48 Lbs./SF)	B1@.022	SF	2.02	.75	2.77
6" steel ceiling joists, 12" OC, 1-5/8" flange					
600S162-33 (20 gauge, 1.48 Lbs./SF)	B1@.029	SF	2.02	.99	3.01
600S162-43 (18 gauge, 1.89 Lbs./SF)	B1@.032	SF	2.58	1.09	3.67
600S162-54 (16 gauge, 2.32 Lbs./SF)	B1@.035	SF	3.16	1.19	4.35
600S162-68 (14 gauge, 2.86 Lbs./SF)	B1@.038	SF	3.89	1.30	5.19
6" steel ceiling joists, 16" OC, 1-5/8" flange					
600S162-33 (20 gauge, 1.15 Lbs./SF)	B1@.022	SF	1.56	.75	2.31
600S162-43 (18 gauge, 1.46 Lbs./SF)	B1@.024	SF	1.99	.82	2.81
600S162-54 (16 gauge, 1.79 Lbs./SF)	B1@.027	SF	2.43	.92	3.35
600S162-68 (14 gauge, 2.21 Lbs./SF)	B1@.029	SF	3.01	.99	4.00
6" steel ceiling joists, 24" OC, 1-5/8" flange					
600S162-33 (20 gauge, .82 Lbs./SF)	B1@.016	SF	1.12	.55	1.67
600S162-43 (18 gauge, 1.04 Lbs./SF)	B1@.018	SF	1.42	.61	2.03
600S162-54 (16 gauge, 1.27 Lbs./SF)	B1@.020	SF	1.73	.68	2.41
600S162-68 (14 gauge, 1.56 Lbs./SF)	B1@.022	SF	2.12	.75	2.87
8" steel ceiling joists, 12" OC, 1-5/8" flange					
800S162-33 (20 gauge, 1.78 Lbs./SF)	B1@.031	SF	2.42	1.06	3.48
800S162-43 (18 gauge, 2.26 Lbs./SF)	B1@.034	SF	3.08	1.16	4.24
800S162-54 (16 gauge, 2.79 Lbs./SF)	B1@.037	SF	3.79	1.26	5.05
800S162-68 (14 gauge, 3.44 Lbs./SF)	B1@.041	SF	4.69	1.40	6.09
800S162-97 (12 gauge, 4.76 Lbs./SF)	B1@.049	SF	6.48	1.67	8.15
8" steel ceiling joists, 16" OC, 1-5/8" flange					
800S162-33 (20 gauge, 1.38 Lbs./SF)	B1@.024	SF	1.87	.82	2.69
800S162-43 (18 gauge, 1.75 Lbs./SF)	B1@.027	SF	2.39	.92	3.31
800S162-54 (16 gauge, 2.15 Lbs./SF)	B1@.029	SF	2.92	.99	3.91
800S162-68 (14 gauge, 2.65 Lbs./SF)	B1@.032	SF	3.60	1.09	4.69
800S162-97 (12 gauge, 3.67 Lbs./SF)	B1@.039	SF	5.00	1.33	6.33
8" steel ceiling joists, 20" OC, 1-5/8" flange					
800S162-33 (20 gauge, 1.14 Lbs./SF)	B1@.020	SF	1.55	.68	2.23
800S162-43 (18 gauge, 1.44 Lbs./SF)	B1@.022	SF	1.96	.75	2.71
800S162-54 (16 gauge, 1.77 Lbs./SF)	B1@.024	SF	2.41	.82	3.23
800S162-68 (14 gauge, 2.18 Lbs./SF)	B1@.026	SF	2.97	.89	3.86
800S162-97 (12 gauge, 3.01 Lbs./SF)	B1@.032	SF	4.10	1.09	5.19

Carpentry, Steel Framing

	Craft@Hrs	Unit	Material	Labor	Total
8" steel ceiling joists, 24" OC, 1-5/8" flange					
800S162-33 (20 gauge, .98 Lbs./SF)	B1@.018	SF	1.34	.61	1.95
800S162-43 (18 gauge, 1.24 Lbs./SF)	B1@.019	SF	1.69	.65	2.34
800S162-54 (16 gauge, 1.52 Lbs./SF)	B1@.021	SF	2.06	.72	2.78
800S162-68 (14 gauge, 1.87 Lbs./SF)	B1@.023	SF	2.54	.78	3.32
800S162-97 (12 gauge, 2.57 Lbs./SF)	B1@.028	SF	3.50	.96	4.46
10" steel ceiling joists, 12" OC, 1-5/8" flange					
1000S162-43 (18 gauge, 2.63 Lbs./SF)	B1@.033	SF	3.58	1.13	4.71
1000S162-54 (16 gauge, 3.24 Lbs./SF)	B1@.036	SF	4.41	1.23	5.64
1000S162-68 (14 gauge, 4.02 Lbs./SF)	B1@.040	SF	5.48	1.36	6.84
1000S162-97 (12 gauge, 5.58 Lbs./SF)	B1@.048	SF	7.60	1.64	9.24
10" steel ceiling joists, 16" OC, 1-5/8" flange					
1000S162-43 (18 gauge, 2.03 Lbs./SF)	B1@.025	SF	2.77	.85	3.62
1000S162-54 (16 gauge, 2.50 Lbs./SF)	B1@.028	SF	3.40	.96	4.36
1000S162-68 (14 gauge, 3.10 Lbs./SF)	B1@.031	SF	4.22	1.06	5.28
1000S162-97 (12 gauge, 4.29 Lbs./SF)	B1@.037	SF	5.85	1.26	7.11
10" steel ceiling joists, 20" OC, 1-5/8" flange					
1000S162-43 (18 gauge, 1.67 Lbs./SF)	B1@.022	SF	2.28	.75	3.03
1000S162-54 (16 gauge, 2.06 Lbs./SF)	B1@.024	SF	2.80	.82	3.62
1000S162-68 (14 gauge, 2.54 Lbs./SF)	B1@.027	SF	3.46	.92	4.38
1000S162-97 (12 gauge, 3.52 Lbs./SF)	B1@.032	SF	4.80	1.09	5.89
10" steel ceiling joists, 24" OC, 1-5/8" flange					
1000S162-43 (18 gauge, 1.44 Lbs./SF)	B1@.019	SF	1.96	.65	2.61
1000S162-54 (16 gauge, 1.76 Lbs./SF)	B1@.021	SF	2.40	.72	3.12
1000S162-68 (14 gauge, 2.18 Lbs./SF)	B1@.023	SF	2.97	.78	3.75
1000S162-97 (12 gauge, 3.01 Lbs./SF)	B1@.027	SF	4.10	.92	5.02
12" steel ceiling joists, 12" OC, 1-5/8" flange					
1200S162-54 (16 gauge, 3.71 Lbs./SF)	B1@.034	SF	5.05	1.16	6.21
1200S162-68 (14 gauge, 4.60 Lbs./SF)	B1@.038	SF	6.26	1.30	7.56
1200S162-97 (12 gauge, 6.39 Lbs./SF)	B1@.045	SF	8.70	1.53	10.23
12" steel ceiling joists, 16" OC, 1-5/8" flange					
1200S162-54 (16 gauge, 2.86 Lbs./SF)	B1@.028	SF	3.89	.96	4.85
1200S162-68 (14 gauge, 3.54 Lbs./SF)	B1@.030	SF	4.82	1.02	5.84
1200S162-97 (12 gauge, 4.92 Lbs./SF)	B1@.036	SF	6.70	1.23	7.93
12" steel ceiling joists, 20" OC, 1-5/8" flange					
1200S162-54 (16 gauge, 2.35 Lbs./SF)	B1@.022	SF	3.20	.75	3.95
1200S162-68 (14 gauge, 2.90 Lbs./SF)	B1@.024	SF	3.95	.82	4.77
1200S162-97 (12 gauge, 4.03 Lbs./SF)	B1@.029	SF	5.49	.99	6.48
12" steel ceiling joists, 24" OC, 1-5/8" flange					
1200S162-54 (16 gauge, 2.01 Lbs./SF)	B1@.020	SF	2.73	.68	3.41
1200S162-68 (14 gauge, 2.49 Lbs./SF)	B1@.022	SF	3.39	.75	4.14
1200S162-97 (12 gauge, 3.45 Lbs./SF)	B1@.026	SF	4.70	.89	5.59
Backing for drywall ceiling Floating backing for drywall ceilings, trim, appliances, fixtures, etc.					
1-1/2" x 1-1/2" (.54 Lbs./LF)	B1@.012	LF	.74	.41	1.15

Carpentry, Steel Framing

Craft@Hrs Unit Material Labor Total

Steel rafters Shed or gable roof with spans from 7'0" to 38'0" and pitch of 3 in 12 to 12 in 12 as published in light-gauge steel framing span tables. Costs per square foot of roof surface. Includes rafters, bracing, screws and minimal waste but no blocking, purlins, ridge boards, collar beams, or gable walls. See costs for blocking, purlins, ridgeboards and collar beams elsewhere in this section. Labor includes layout, assembly, and alignment. Figures in parentheses show weight of steel per square foot of roof.

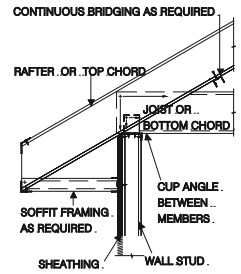

Using light gauge steel rafters at	—	Lb	1.36	—	1.36
Add for hip roof	B1@.009	SF	—	.31	.31
5-1/2" steel rafters, 12" OC, 1-5/8" flange					
550S162-33 (20 gauge, 1.18 Lbs./SF)	B1@.037	SF	1.61	1.26	2.87
550S162-43 (18 gauge, 1.51 Lbs./SF)	B1@.041	SF	2.05	1.40	3.45
550S162-54 (16 gauge, 1.87 Lbs./SF)	B1@.045	SF	2.54	1.53	4.07
550S162-68 (14 gauge, 2.31 Lbs./SF)	B1@.050	SF	3.15	1.71	4.86
5-1/2" steel rafters, 16" OC, 1-5/8" flange					
550S162-33 (20 gauge, .90 Lbs./SF)	B1@.031	SF	1.23	1.06	2.29
550S162-43 (18 gauge, 1.15 Lbs./SF)	B1@.034	SF	1.56	1.16	2.72
550S162-54 (16 gauge, 1.42 Lbs./SF)	B1@.037	SF	1.93	1.26	3.19
550S162-68 (14 gauge, 1.75 Lbs./SF)	B1@.041	SF	2.39	1.40	3.79
5-1/2" steel rafters, 24" OC, 1-5/8" flange					
500S162-33 (20 gauge, .63 Lbs./SF)	B1@.024	SF	.86	.82	1.68
500S162-43 (18 gauge, .79 Lbs./SF)	B1@.026	SF	1.07	.89	1.96
500S162-54 (16 gauge, .97 Lbs./SF)	B1@.029	SF	1.32	.99	2.31
500S162-68 (14 gauge, 1.19 Lbs./SF)	B1@.032	SF	1.62	1.09	2.71
8" steel rafters, 12" OC, 1-5/8" flange					
800S162-33 (20 gauge, 1.48 Lbs./SF)	B1@.048	SF	2.02	1.64	3.66
800S162-43 (18 gauge, 1.90 Lbs./SF)	B1@.053	SF	2.59	1.81	4.40
800S162-54 (16 gauge, 2.35 Lbs./SF)	B1@.058	SF	3.20	1.98	5.18
800S162-68 (14 gauge, 2.91 Lbs./SF)	B1@.064	SF	3.96	2.18	6.14
800S162-97 (12 gauge, 4.05 Lbs./SF)	B1@.070	SF	5.51	2.39	7.90
8" steel rafters, 16" OC, 1-5/8" flange					
800S162-33 (20 gauge, 1.13 Lbs./SF)	B1@.040	SF	1.54	1.36	2.90
800S162-43 (18 gauge, 1.44 Lbs./SF)	B1@.044	SF	1.96	1.50	3.46
800S162-54 (16 gauge, 1.78 Lbs./SF)	B1@.048	SF	2.42	1.64	4.06
800S162-68 (14 gauge, 2.20 Lbs./SF)	B1@.053	SF	2.99	1.81	4.80
800S162-97 (12 gauge, 3.06 Lbs./SF)	B1@.058	SF	4.16	1.98	6.14
8" steel rafters, 24" OC, 1-5/8" flange					
800S162-33 (20 gauge, .78 Lbs./SF)	B1@.032	SF	1.06	1.09	2.15
800S162-43 (18 gauge, .99 Lbs./SF)	B1@.035	SF	1.35	1.19	2.54
800S162-54 (16 gauge, 1.21 Lbs./SF)	B1@.039	SF	1.65	1.33	2.98
800S162-68 (14 gauge, 1.49 Lbs./SF)	B1@.043	SF	2.03	1.47	3.50
800S162-97 (12 gauge, 2.06 Lbs./SF)	B1@.047	SF	2.80	1.60	4.40
10" steel rafters, 12" OC, 1-5/8" flange					
1000S162-43 (18 gauge, 2.20 Lbs./SF)	B1@.060	SF	2.99	2.05	5.04
1000S162-54 (16 gauge, 2.73 Lbs./SF)	B1@.066	SF	3.72	2.25	5.97
1000S162-68 (14 gauge, 3.40 Lbs./SF)	B1@.072	SF	3.88	2.46	6.34
1000S162-97 (12 gauge, 4.74 Lbs./SF)	B1@.080	SF	6.45	2.73	9.18
10" steel rafters, 16" OC, 1-5/8" flange					
1000S162-43 (18 gauge, 1.67 Lbs./SF)	B1@.048	SF	2.28	1.64	3.92
1000S162-54 (16 gauge, 2.07 Lbs./SF)	B1@.053	SF	2.82	1.81	4.63
1000S162-68 (14 gauge, 2.57 Lbs./SF)	B1@.058	SF	3.50	1.98	5.48
1000S162-97 (12 gauge, 3.57 Lbs./SF)	B1@.064	SF	4.86	2.18	7.04

Carpentry, Steel Framing

	Craft@Hrs	Unit	Material	Labor	Total
10" steel rafters, 24" OC, 1-5/8" flange					
1000S162-43 (18 gauge, 1.14 Lbs./SF)	B1@.039	SF	1.55	1.33	2.88
1000S162-54 (16 gauge, 1.40 Lbs./SF)	B1@.042	SF	1.91	1.43	3.34
1000S162-68 (14 gauge, 1.74 Lbs./SF)	B1@.047	SF	2.37	1.60	3.97
1000S162-97 (12 gauge, 2.41 Lbs./SF)	B1@.051	SF	3.28	1.74	5.02
12" steel rafters, 12" OC, 1-5/8" flange					
1200S162-54 (16 gauge, 3.12 Lbs./SF)	B1@.066	SF	4.25	2.25	6.50
1200S162-68 (14 gauge, 3.88 Lbs./SF)	B1@.073	SF	5.28	2.49	7.77
1200S162-97 (12 gauge, 5.43 Lbs./SF)	B1@.080	SF	7.40	2.73	10.13
12" steel rafters, 16" OC, 1-5/8" flange					
1200S162-54 (16 gauge, 2.36 Lbs./SF)	B1@.053	SF	3.21	1.81	5.02
1200S162-68 (14 gauge, 2.93 Lbs./SF)	B1@.059	SF	3.98	2.01	5.99
1200S162-97 (12 gauge, 4.09 Lbs./SF)	B1@.064	SF	5.57	2.18	7.75
12" steel rafters, 24" OC, 1-5/8" flange					
1200S162-54 (16 gauge, 1.60 Lbs./SF)	B1@.043	SF	2.18	1.47	3.65
1200S162-68 (14 gauge, 1.98 Lbs./SF)	B1@.047	SF	2.70	1.60	4.30
1200S162-97 (12 gauge, 2.75 Lbs./SF)	B1@.052	SF	3.75	1.77	5.52
Steel trimmers At floor openings, stairwells, skylights, dormers, etc. Consists of one C-shaped member nested in same size track. Labor includes layout, assembly and alignment. Figures in parentheses show weight of steel per linear foot of trimmer. Includes screws and minimal waste.					
Using light-gauge steel framing materials	—	Lb	1.36	—	1.36
3-1/2" steel trimmers, 1-5/8" flange					
350S162-33 (20 gauge, 1.76 Lbs./LF)	B1@.020	LF	2.40	.68	3.08
350S162-43 (18 gauge, 2.29 Lbs./LF)	B1@.020	LF	3.11	.68	3.79
350S162-54 (16 gauge, 2.85 Lbs./LF)	B1@.022	LF	3.88	.75	4.63
350S162-68 (14 gauge, 3.60 Lbs./LF)	B1@.023	LF	4.90	.78	5.68
5-1/2" steel trimmers, 1-5/8" flange					
550S162-33 (20 gauge, 2.23 Lbs./LF)	B1@.031	LF	3.04	1.06	4.10
550S162-43 (18 gauge, 2.90 Lbs./LF)	B1@.031	LF	3.95	1.06	5.01
550S162-54 (16 gauge, 3.63 Lbs./LF)	B1@.034	LF	4.94	1.16	6.10
550S162-68 (14 gauge, 4.54 Lbs./LF)	B1@.035	LF	6.18	1.19	7.37
8" steel trimmers, 1-5/8" flange					
800S162-33 (20 gauge, 2.82 Lbs./LF)	B1@.042	LF	3.84	1.43	5.27
800S162-43 (18 gauge, 3.67 Lbs./LF)	B1@.042	LF	5.00	1.43	6.43
800S162-54 (16 gauge, 4.59 Lbs./LF)	B1@.046	LF	6.25	1.57	7.82
800S162-68 (14 gauge, 5.75 Lbs./LF)	B1@.047	LF	7.83	1.60	9.43
800S162-97 (12 gauge, 8.13 Lbs./LF)	B1@.048	LF	11.10	1.64	12.74
10" steel trimmers, 1-5/8" flange					
1000S162-43 (18 gauge, 4.28 Lbs./LF)	B1@.052	LF	5.82	1.77	7.59
1000S162-54 (16 gauge, 5.35 Lbs./LF)	B1@.052	LF	7.29	1.77	9.06
1000S162-68 (14 gauge, 6.72 Lbs./LF)	B1@.057	LF	9.15	1.94	11.09
1000S162-97 (12 gauge, 9.51 Lbs./LF)	B1@.058	LF	13.00	1.98	14.98
12" steel trimmers, 1-5/8" flange					
1200S162-54 (16 gauge, 6.13 Lbs./LF)	B1@.063	LF	8.35	2.15	10.50
1200S162-68 (14 gauge, 7.69 Lbs./LF)	B1@.066	LF	10.50	2.25	12.75
1200S162-97 (12 gauge, 10.89 Lbs./LF)	B1@.069	LF	14.80	2.35	17.15

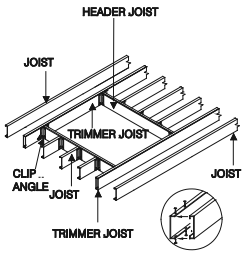

Carpentry, Steel Framing

	Craft@Hrs	Unit	Material	Labor	Total
Steel collar beams Cost per linear foot of collar beam or rafter brace, including screws.					
350S162-33 (3-1/2", 33 mil, 20 gauge)	B1@.007	LF	.91	.24	1.15
550S162-43 (5-1/2", 43 mil, 18 gauge)	B1@.014	LF	1.56	.48	2.04
Steel purlins Purlins or "perling" installed below roof rafters.					
350S162-33 (3-1/2", 33 mil, 20 gauge)	B1@.013	LF	1.19	.44	1.63
350S162-43 (3-1/2", 43 mil, 18 gauge)	B1@.019	LF	.91	.65	1.56
Steel dormer studs Per square foot of wall area					
350S162-33 (3-1/2", 33 mil, 20 gauge)	B1@.036	SF	1.16	1.23	2.39
Steel ridgeboard Horizontal support at top of rafter ends. Consists of one C-shaped member nested in same size track. Labor includes layout, assembly and alignment. Figures in parentheses show weight of steel per linear foot of ridgeboard. Includes screws and minimal waste.					
Using light-gauge steel framing materials	—	Lb	1.36	—	1.36
5-1/2" steel ridgeboard, 1-5/8" flange					
550S162-33 (20 gauge, 2.23 Lbs./LF)	B1@.031	LF	3.04	1.06	4.10
550S162-43 (18 gauge, 2.90 Lbs./LF)	B1@.031	LF	3.95	1.06	5.01
550S162-54 (16 gauge, 3.63 Lbs./LF)	B1@.034	LF	4.94	1.16	6.10
550S162-68 (14 gauge, 4.54 Lbs./LF)	B1@.035	LF	6.18	1.19	7.37
8" steel ridgeboard, 1-5/8" flange					
800S162-33 (20 gauge, 2.82 Lbs./LF)	B1@.042	LF	3.84	1.43	5.27
800S162-43 (18 gauge, 3.67 Lbs./LF)	B1@.042	LF	5.00	1.43	6.43
800S162-54 (16 gauge, 4.59 Lbs./LF)	B1@.046	LF	6.25	1.57	7.82
800S162-68 (14 gauge, 5.75 Lbs./LF)	B1@.047	LF	7.83	1.60	9.43
800S162-97 (12 gauge, 8.13 Lbs./LF)	B1@.048	LF	11.10	1.64	12.74
10" steel ridgeboard, 1-5/8" flange					
1000S162-43 (18 gauge, 4.28 Lbs./LF)	B1@.052	LF	5.82	1.77	7.59
1000S162-54 (16 gauge, 5.35 Lbs./LF)	B1@.052	LF	7.29	1.77	9.06
1000S162-68 (14 gauge, 6.72 Lbs./LF)	B1@.057	LF	9.15	1.94	11.09
1000S162-97 (12 gauge, 9.51 Lbs./LF)	B1@.058	LF	13.00	1.98	14.98
12" steel ridgeboard, 1-5/8" flange					
1200S162-54 (16 gauge, 6.13 Lbs./LF)	B1@.063	LF	8.35	2.15	10.50
1200S162-68 (14 gauge, 7.69 Lbs./LF)	B1@.066	LF	10.50	2.25	12.75
1200S162-97 (12 gauge, 10.89 Lbs./LF)	B1@.069	LF	14.80	2.35	17.15
Steel roof trusses Site-fabricated and set by hand 24" OC for any roof slope from 3 in 12 to 12 in 12 so long as the total truss height does not exceed 12' from bottom chord to highest point on truss. Trusses over 12' high may cost up to 100% more. Costs are per square foot (SF) of horizontal area covered.					
Using light-gauge steel framing materials at	—	Lb	1.36	—	1.36
4" C-shaped top and bottom chords, members unpunched					
Up to 38' span	B1@.029	SF	6.28	.99	7.27
40' to 50' span	B1@.037	SF	7.84	1.26	9.10
Fink truss "W" (conventional roof truss). 4" C-shaped top and bottom chords					
Up to 38' span	B1@.023	SF	5.49	.78	6.27
40' to 50' span	B1@.029	SF	6.48	.99	7.47
6" C-shaped top and bottom chords, members unpunched					
Up to 38' span	B1@.027	SF	6.60	.92	7.52
40' to 50' span	B1@.035	SF	7.96	1.19	9.15

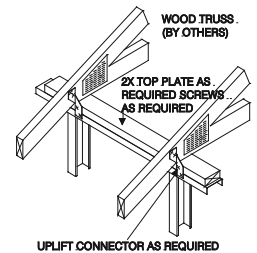

Carpentry, Piecework, Steel

	Craft@Hrs	Unit	Material	Labor	Total
Truss with gable fill at 16" OC					
28' span, 5 in 12 slope	B1@1.27	Ea	446.00	43.30	489.30
32' span, 5 in 12 slope	B1@1.68	Ea	552.00	57.30	609.30
40' span, 5 in 12 slope	B1@2.30	Ea	772.00	78.50	850.50

Piecework Steel Framing Steel framing on residential tracts is sometimes done by sub-contractors who bid at piecework rates (such as per square foot of floor). The figures below list typical piecework rates for repetitive framing and assume all materials are supplied to the framing subcontractor. No figures appear in the Craft@Hrs column because the work is done for a fixed price per square foot and the labor productivity can be expected to vary widely.

Steel frame layout and bottom track Piecework rates

Lay out wall track according to the plans (snap chalk lines for wall track, mark location for studs, windows, doors and framing details), cut top and bottom track and install bottom track. Costs per square foot of floor (excluding garage).

Custom or more complex jobs	—	SF	—	.29	.29
Larger job, longer runs	—	SF	—	.19	.19

Steel exterior wall framing Piecework rates

Measure, cut, fit, assemble, and tip up walls, including studs, track, cripples, x-bracing, trimmers and blocking. Costs per square foot of floor.

Complex job, radius walls, rake walls	—	SF	—	.84	.84
Larger job, 8' high walls, fewer partitions	—	SF	—	.29	.29

Plumb and align steel framed walls Piecework rates

Align walls, adjust walls to vertical and install temporary braces as needed, fasten nuts on anchor bolts or shoot power driven fasteners through wall track into the slab. Based on accuracy to 3/16". Costs per square foot of floor are shown below.

Small or complex job, many braces	—	SF	—	.28	.28
Larger job, fewer braces	—	SF	—	.17	.17

Install steel floor or ceiling joists Piecework rates

Lay out, cut and install floor or ceiling joists, including rim track, doubled joists, straps, joist hangers, blocking at 12' OC and ceiling backing for drywall. Based on larger jobs with simple joist layouts set 24" OC and pre-cut blocking supplied by the general contractor. Add the cost of floor beams, if required. Costs per square foot of horizontal joist area. More complex jobs with shorter runs may cost 50% more.

Install 6" ceiling or floor joists 24" OC					
600S200-33 (2" flange, 20 gauge)	—	SF	—	.20	.20
600S200-43 (2" flange, 18 gauge)	—	SF	—	.20	.20
600S200-54 (2" flange, 16 gauge)	—	SF	—	.21	.21
600S200-68 (2" flange, 14 gauge)	—	SF	—	.22	.22
Install 8" ceiling or floor joists 24" OC					
800S200-43 (2" flange, 18 gauge)	—	SF	—	.20	.20
800S200-54 (2" flange, 16 gauge)	—	SF	—	.21	.21
800S200-68 (2" flange, 14 gauge)	—	SF	—	.22	.22
800S200-97 (2" flange, 12 gauge)	—	SF	—	.24	.24

Carpentry, Piecework, Steel

	Craft@Hrs	Unit	Material	Labor	Total
Install 10" ceiling or floor joists 24" OC					
1000S200-43 (2" flange, 18 gauge)	—	SF	—	.21	.21
1000S200-54 (2" flange, 16 gauge)	—	SF	—	.22	.22
1000S200-68 (2" flange, 14 gauge)	—	SF	—	.23	.23
1000S200-97 (2" flange, 12 gauge)	—	SF	—	.25	.25
Install 12" ceiling or floor joists 24" OC					
1200S200-54 (2" flange, 16 gauge)	—	SF	—	.23	.23
1200S200-68 (2" flange, 14 gauge)	—	SF	—	.24	.24
1200S200-97 (2" flange, 12 gauge)	—	SF	—	.26	.26
Add for other than 24" joist spacing					
Add for 12" OC spacing	—	SF	—	.16	.16
Add for 16" OC spacing	—	SF	—	.06	.06
Add for 20" OC spacing	—	SF	—	.03	.03

Install plywood floor sheathing on steel joists Piecework rates

Lay out, cut, fit and install 5/8" or 3/4" tongue and groove plywood floor sheathing, including blocking as required. Based on nailing done with a pneumatic nailer and pins supplied by the general contractor, or screwing done with a collated screw gun and screws supplied by the general contractor. Costs per square foot of sheathing installed.

Smaller, cut-up job	—	SF	—	.26	.26
Larger job, longer runs	—	SF	—	.21	.21
Add for 1-1/8" sheathing	—	SF	—	.06	.06

Install structural shear panels on steel studs Piecework rates

Lay out, cut, fit and install structural 3/8" or 1/2" plywood wall panels. These figures assume steel shear studs were set correctly by others and that panel nails or screws are driven at 4" OC with a pneumatic nailer or collated screwgun. Not including hold-down straps, posts, shear blocking or extra studs. Costs per 4' x 9' panel installed.

Small job, many openings, 2nd floor	—	Ea	—	13.60	13.60
Larger job, few openings, 1st floor	—	Ea	—	8.39	8.39

Steel roof trusses Piecework rates

Setting and anchoring engineered gable and hip steel roof trusses 24" OC on prepared wall top track. These figures assume that lifting equipment is provided by the general contractor (if required) and that the truss supplier provides a fill package, spreader blocks for each plate and the ridge and jack rafters (if required). Includes installation of ceiling backing where required and rat runs at the bottom chord. Costs per square foot of plan area under the truss. Small job assumes multiple California fill between roof surfaces and understacking.

Small job, rake fill above a partition wall	—	SF	—	.90	.90
Larger job, little or no fill or understacking	—	SF	—	.52	.52

Conventional roof framing Piecework rates

Calculate lengths, lay out, cut and install steel 8", 10" or 12" common, hip, valley and jack rafters on parallel and horizontal top track. Costs per square foot of plan area under the roof. Slope to 6 in 12.

Add for slope over 6 in 12	—	SF	—	.29	.29
----------------------------	---	----	---	-----	-----

Steel rafters 12" OC, small job, cut-up roof, few common rafters

800S162-33 (8", 1-5/8" flange, 20 gauge)	—	SF	—	1.83	1.83
800S162-43 (8", 1-5/8" flange, 18 gauge)	—	SF	—	1.85	1.85
800S162-54 (8", 1-5/8" flange, 16 gauge)	—	SF	—	1.88	1.88
800S162-68 (8", 1-5/8" flange, 14 gauge)	—	SF	—	1.96	1.96
800S162-97 (8", 1-5/8" flange, 12 gauge)	—	SF	—	2.06	2.06
1000S162-43 (10", 1-5/8" flange, 18 gauge)	—	SF	—	1.90	1.90

Carpentry, Piecework, Steel

	Craft@Hrs	Unit	Material	Labor	Total
1000S162-54 (10", 1-5/8" flange, 16 gauge)	—	SF	—	1.92	1.92
1000S162-68 (10", 1-5/8" flange, 14 gauge)	—	SF	—	2.00	2.00
1000S162-97 (10", 1-5/8" flange, 12 gauge)	—	SF	—	2.12	2.12
1200S162-54 (12", 1-5/8" flange, 16 gauge)	—	SF	—	1.98	1.98
1200S162-68 (12", 1-5/8" flange, 14 gauge)	—	SF	—	2.05	2.05
1200S162-97 (12", 1-5/8" flange, 12 gauge)	—	SF	—	2.18	2.18
Steel rafters 16" OC, small job, cut-up roof, few common rafters					
800S162-33 (8", 1-5/8" flange, 20 gauge)	—	SF	—	1.54	1.54
800S162-43 (8", 1-5/8" flange, 18 gauge)	—	SF	—	1.55	1.55
800S162-54 (8", 1-5/8" flange, 16 gauge)	—	SF	—	1.57	1.57
800S162-68 (8", 1-5/8" flange, 14 gauge)	—	SF	—	1.65	1.65
800S162-97 (8", 1-5/8" flange, 12 gauge)	—	SF	—	1.76	1.76
1000S162-43 (10", 1-5/8" flange, 18 gauge)	—	SF	—	1.60	1.60
1000S162-54 (10", 1-5/8" flange, 16 gauge)	—	SF	—	1.61	1.61
1000S162-68 (10", 1-5/8" flange, 14 gauge)	—	SF	—	1.68	1.68
1000S162-97 (10", 1-5/8" flange, 12 gauge)	—	SF	—	1.81	1.81
1200S162-54 (12", 1-5/8" flange, 16 gauge)	—	SF	—	1.67	1.67
1200S162-68 (12", 1-5/8" flange, 14 gauge)	—	SF	—	1.76	1.76
1200S162-97 (12", 1-5/8" flange, 12 gauge)	—	SF	—	1.84	1.84
Steel rafters 24" OC, small job, cut-up roof, few common rafters					
800S162-33 (8", 1-5/8" flange, 20 gauge)	—	SF	—	.91	.91
800S162-43 (8", 1-5/8" flange, 18 gauge)	—	SF	—	.92	.92
800S162-54 (8", 1-5/8" flange, 16 gauge)	—	SF	—	.93	.93
800S162-68 (8", 1-5/8" flange, 14 gauge)	—	SF	—	.97	.97
800S162-97 (8", 1-5/8" flange, 12 gauge)	—	SF	—	1.03	1.03
1000S162-43 (10", 1-5/8" flange, 18 gauge)	—	SF	—	.94	.94
1000S162-54 (10", 1-5/8" flange, 16 gauge)	—	SF	—	.95	.95
1000S162-68 (10", 1-5/8" flange, 14 gauge)	—	SF	—	.99	.99
1000S162-97 (10", 1-5/8" flange, 12 gauge)	—	SF	—	1.07	1.07
1200S162-54 (12", 1-5/8" flange, 16 gauge)	—	SF	—	.98	.98
1200S162-68 (12", 1-5/8" flange, 14 gauge)	—	SF	—	1.03	1.03
1200S162-97 (12", 1-5/8" flange, 12 gauge)	—	SF	—	1.11	1.11
Steel rafters 12" OC, larger job, longer runs, nearly all common rafters					
800S162-33 (8", 1-5/8" flange, 20 gauge)	—	SF	—	.91	.91
800S162-43 (8", 1-5/8" flange, 18 gauge)	—	SF	—	.92	.92
800S162-54 (8", 1-5/8" flange, 16 gauge)	—	SF	—	.93	.93
800S162-68 (8", 1-5/8" flange, 16 gauge)	—	SF	—	.97	.97
800S162-97 (8", 1-5/8" flange, 12 gauge)	—	SF	—	1.03	1.03
1000S162-43 (10", 1-5/8" flange, 18 gauge)	—	SF	—	.94	.94
1000S162-54 (10", 1-5/8" flange, 16 gauge)	—	SF	—	.95	.95
1000S162-68 (10", 1-5/8" flange, 14 gauge)	—	SF	—	.99	.99
1000S162-97 (10", 1-5/8" flange, 12 gauge)	—	SF	—	1.07	1.07
1200S162-54 (12", 1-5/8" flange, 16 gauge)	—	SF	—	.98	.98
1200S162-68 (12", 1-5/8" flange, 14 gauge)	—	SF	—	1.03	1.03
1200S162-97 (12", 1-5/8" flange, 12 gauge)	—	SF	—	1.11	1.11
Steel rafters 16" OC, larger job, longer runs, nearly all common rafters					
800S162-33 (8", 1-5/8" flange, 20 gauge)	—	SF	—	.82	.82
800S162-43 (8", 1-5/8" flange, 18 gauge)	—	SF	—	.82	.82
800S162-54 (8", 1-5/8" flange, 16 gauge)	—	SF	—	.83	.83
800S162-68 (8", 1-5/8" flange, 16 gauge)	—	SF	—	.87	.87
800S162-97 (8", 1-5/8" flange, 12 gauge)	—	SF	—	.90	.90

Carpentry, Piecework, Steel

	Craft@Hrs	Unit	Material	Labor	Total
1000S162-43 (10", 1-5/8" flange, 18 gauge)	—	SF	—	.84	.84
1000S162-54 (10", 1-5/8" flange, 16 gauge)	—	SF	—	.86	.86
1000S162-68 (10", 1-5/8" flange, 14 gauge)	—	SF	—	.88	.88
1000S162-97 (10", 1-5/8" flange, 12 gauge)	—	SF	—	.92	.92
1200S162-54 (12", 1-5/8" flange, 16 gauge)	—	SF	—	.88	.88
1200S162-68 (12", 1-5/8" flange, 14 gauge)	—	SF	—	.90	.90
1200S162-97 (12", 1-5/8" flange, 12 gauge)	—	SF	—	.94	.94
Steel rafters 24" OC, larger job, longer runs, nearly all common rafters					
800S162-33 (8", 1-5/8" flange, 20 gauge)	—	SF	—	.53	.53
800S162-43 (8", 1-5/8" flange, 18 gauge)	—	SF	—	.54	.54
800S162-54 (8", 1-5/8" flange, 16 gauge)	—	SF	—	.54	.54
800S162-68 (8", 1-5/8" flange, 16 gauge)	—	SF	—	.56	.56
800S162-97 (8", 1-5/8" flange, 12 gauge)	—	SF	—	.59	.59
1000S162-43 (10", 1-5/8" flange, 18 gauge)	—	SF	—	.55	.55
1000S162-54 (10", 1-5/8" flange, 16 gauge)	—	SF	—	.55	.55
1000S162-68 (10", 1-5/8" flange, 14 gauge)	—	SF	—	.58	.58
1000S162-97 (10", 1-5/8" flange, 12 gauge)	—	SF	—	.60	.60
1200S162-54 (12", 1-5/8" flange, 16 gauge)	—	SF	—	.56	.56
1200S162-68 (12", 1-5/8" flange, 14 gauge)	—	SF	—	.59	.59
1200S162-97 (12", 1-5/8" flange, 12 gauge)	—	SF	—	.61	.61

Fascia, wood Piecework rates

Applied to rafter tails and as a barge rafter on gable ends. Includes trimming the rafter tails to the correct length and installing outlookers at gable ends. Costs per linear foot of 2" x 8" fascia installed.

Small job, short runs, with molding	—	LF	—	3.02	3.02
Larger job, longer runs	—	LF	—	1.64	1.64

Install roof sheathing on steel rafters Piecework rates

Lay out, cut, fit and install 1/2" or 5/8" plywood roof sheathing, including blocking and 1" x 8" starter board on overhangs as required. Based on nailing done with a pneumatic nailer and nails or collated screwgun and screws supplied by the general contractor. Slope to 6 in 12. Costs per square foot of sheathing installed.

Smaller, cut-up hip and valley job	—	SF	—	.27	.27
Larger job, longer runs	—	SF	—	.21	.21
Add for slope over 6 in 12	—	SF	—	.11	.11

Carpeting, Subcontract Costs listed are typical for a complete residential job and include consultation, measurement, pad, carpet, and professional installation of pad and carpet using tack strips and hot melt tape on seams. Prices for brand name (specification grade) carpet will be up to 50% higher.

Minimum quality, 25 to 28 oz. olefin (polypropylene) carpet

Including a 1/2" (4 lb density) rebond pad	—	SY	—	—	24.50
--	---	----	---	---	-------

Minimum quality, 25 to 35 oz. face weight nylon carpet

Including a 1/2" (4 lb density) rebond pad	—	SY	—	—	31.70
--	---	----	---	---	-------

Good quality, 35 to 50 oz. face weight nylon carpet

Including a 1/2" (6 lb density) rebond pad	—	SY	—	—	44.90
--	---	----	---	---	-------

Better quality, 50 (plus) oz. face weight nylon carpet

Including a 1/2" (6 lb density) rebond pad	—	SY	—	—	62.20
--	---	----	---	---	-------

Wool tufted carpet	—	SY	—	—	82.50
--------------------	---	----	---	---	-------

Installation cost alone (residential)	—	SY	—	—	7.47
---------------------------------------	---	----	---	---	------

Installation cost alone (commercial)	—	SY	—	—	6.32
--------------------------------------	---	----	---	---	------

Add for typical furniture moving	—	SY	—	—	2.28
----------------------------------	---	----	---	---	------

Add for waterfall (box steps) stairways	—	Riser	—	—	8.82
---	---	-------	---	---	------

Carports

	Craft@Hrs	Unit	Material	Labor	Total
Add for wrapped steps (open riser), sewn	—	Step	—	—	11.70
Add for sewn edge treatment on one side	—	Riser	—	—	14.20
Add for circular stair steps, costs vary depending on frame					
Add for circular stairs, typical cost	—	Step	—	—	18.90

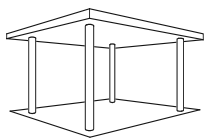

Carports Material costs include all hardware. Labor is based on bolting posts to an existing concrete slab. Steel frame, 4" x 4" galvanized 14 gauge posts, 14 gauge purlins, 26 gauge rib metal roofing, 90 MPH wind load.

18' wide x 18' long x 8' high, four posts, 20 PSF snow load					
Natural zinc finish	B1@8.00	Ea	2,420.00	273.00	2,693.00
White enamel finish	B1@8.00	Ea	2,660.00	273.00	2,933.00
18' wide x 18' long x 8' high, six posts, 40 PSF snow load					
Natural zinc finish	B1@9.00	Ea	2,970.00	307.00	3,277.00
White enamel finish	B1@9.00	Ea	3,220.00	307.00	3,527.00
36' wide x 18' long x 8' high, six posts, 20 PSF snow load					
Natural zinc finish	B1@10.0	Ea	3,710.00	341.00	4,051.00
White enamel finish	B1@10.0	Ea	4,210.00	341.00	4,551.00
36' wide x 18' long x 8' high, nine posts, 40 PSF snow load					
Natural zinc finish	B1@11.5	Ea	4,630.00	392.00	5,022.00
White enamel finish	B1@11.5	Ea	5,130.00	392.00	5,522.00
15' wide x 35' long x 15' high, ten posts, 40 PSF snow load					
Natural zinc finish	B1@13.0	Ea	4,580.00	443.00	5,023.00
White enamel finish	B1@13.0	Ea	5,250.00	443.00	5,693.00

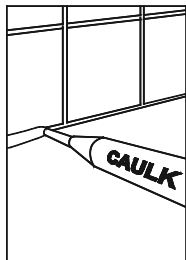

Caulking Material costs are typical costs for bead diameter listed. Figures in parentheses indicate approximate coverage including 5% waste. Labor costs are for good quality application on smooth to slightly irregular surfaces. Per LF of bead length.

Concrete sealant with polyurethane

Concrete sealant, per ounce	—	Oz	.75	—	.75
1/4" (2.91 LF per fluid oz.)	BC@.025	LF	.26	.94	1.20
3/8" (1.29 LF per fluid oz.)	BC@.030	LF	.58	1.13	1.71
1/2" (.728 LF per fluid oz.)	BC@.033	LF	1.02	1.24	2.26

Acoustical caulk, flexible, sound deadening

Acoustical caulk, per ounce	—	Oz	.33	—	.33
1/8" (11.6 LF per fluid oz.)	BC@.018	LF	.03	.68	.71
1/4" (2.91 LF per fluid oz.)	BC@.025	LF	.11	.94	1.05
3/8" (1.29 LF per fluid oz.)	BC@.030	LF	.26	1.13	1.39
1/2" (.728 LF per fluid oz.)	BC@.033	LF	.46	1.24	1.70

Acrylic latex caulk, premium quality, 35 year life expectancy

Acrylic latex caulk, per ounce	—	Oz	.25	—	.25
1/8" (11.6 LF per fluid oz.)	BC@.018	LF	.02	.68	.70
1/4" (2.91 LF per fluid oz.)	BC@.025	LF	.09	.94	1.03
3/8" (1.29 LF per fluid oz.)	BC@.030	LF	.19	1.13	1.32
1/2" (.728 LF per fluid oz.)	BC@.033	LF	.34	1.24	1.58

Painter's acrylic latex caulk, paintable in 30 minutes

Painter's acrylic latex caulk, per ounce	—	Oz	.18	—	.18
1/8" (11.6 LF per fluid oz.)	BC@.018	LF	.02	.68	.70
1/4" (2.91 LF per fluid oz.)	BC@.025	LF	.06	.94	1.00
3/8" (1.29 LF per fluid oz.)	BC@.030	LF	.14	1.13	1.27
1/2" (.728 LF per fluid oz.)	BC@.033	LF	.24	1.24	1.48

Caulking

	Craft@Hrs	Unit	Material	Labor	Total
Elastomeric latex sealant. Clearer than silicone					
Elastomeric latex sealant, per ounce	—	Oz	.81	—	.81
1/8" (11.6 LF per fluid oz.)	BC@.018	LF	.07	.68	.75
1/4" (2.91 LF per fluid oz.)	BC@.025	LF	.28	.94	1.22
3/8" (1.29 LF per fluid oz.)	BC@.030	LF	.63	1.13	1.76
1/2" (.728 LF per fluid oz.)	BC@.033	LF	1.11	1.24	2.35
Tub & tile caulk, for tubs, showers and sinks					
Tub & tile caulk, per ounce	—	Oz	.65	—	.65
1/8" (11.6 LF per fluid oz.)	BC@.018	LF	.06	.68	.74
1/4" (2.91 LF per fluid oz.)	BC@.025	LF	.22	.94	1.16
3/8" (1.29 LF per fluid oz.)	BC@.030	LF	.51	1.13	1.64
1/2" (.728 LF per fluid oz.)	BC@.033	LF	.90	1.24	2.14
Fire barrier latex caulk, four hour fire rating for pipes up to 30 inches					
Fire barrier latex caulk, per ounce	—	Oz	1.28	—	1.28
1/8" (11.6 LF per fluid oz.)	BC@.018	LF	.11	.68	.79
1/4" (2.91 LF per fluid oz.)	BC@.022	LF	.44	.83	1.27
3/8" (1.29 LF per fluid oz.)	BC@.027	LF	.99	1.02	2.01
1/2" (.728 LF per fluid oz.)	BC@.030	LF	1.76	1.13	2.89
Silicone caulk					
Siliconized acrylic caulk, per ounce	—	Oz	.76	—	.76
1/8" (11.6 LF per fluid oz.)	BC@.018	LF	.07	.68	.75
1/4" (2.91 LF per fluid oz.)	BC@.025	LF	.26	.94	1.20
3/8" (1.29 LF per fluid oz.)	BC@.030	LF	.59	1.13	1.72
1/2" (.728 LF per fluid oz.)	BC@.033	LF	1.04	1.24	2.28
Marine adhesive/sealant, premium quality					
Silicon rubber sealant, per ounce	—	Oz	2.64	—	2.64
1/8" (11.6 LF per fluid oz.)	BC@.043	LF	.23	1.62	1.85
1/4" (2.91 LF per fluid oz.)	BC@.048	LF	.91	1.81	2.72
3/8" (1.29 LF per fluid oz.)	BC@.056	LF	2.05	2.11	4.16
1/2" (.728 LF per fluid oz.)	BC@.060	LF	3.63	2.26	5.89
Anti-algae and mildew-resistant tub caulk, premium quality white or clear silicone					
Anti-algae tub caulk, per ounce	—	Oz	.70	—	.70
1/8" (11.6 LF per fluid oz.)	BC@.018	LF	.06	.68	.74
1/4" (2.91 LF per fluid oz.)	BC@.022	LF	.24	.83	1.07
3/8" (1.29 LF per fluid oz.)	BC@.027	LF	.54	1.02	1.56
1/2" (.728 LF per fluid oz.)	BC@.030	LF	.95	1.13	2.08
Vinyl window and siding sealant, permanently flexible, paintable					
Vinyl window and siding sealant, per ounce	—	Oz	.79	—	.79
1/8" (11.6 LF per fluid oz.)	BC@.018	LF	.07	.68	.75
1/4" (2.91 LF per fluid oz.)	BC@.022	LF	.27	.83	1.10
3/8" (1.29 LF per fluid oz.)	BC@.027	LF	.61	1.02	1.63
1/2" (.728 LF per fluid oz.)	BC@.030	LF	1.08	1.13	2.21
Gutter and flashing sealant for gutters, downspouts, lap joints, flashing, vents, aluminum siding, and other metal joints. Meets ASTM C-1085					
Gutter and flashing sealant, per ounce	—	Oz	.98	—	.98
1/8" (11.6 LF per fluid oz.)	BC@.018	LF	.08	.68	.76
1/4" (2.91 LF per fluid oz.)	BC@.022	LF	.34	.83	1.17
3/8" (1.29 LF per fluid oz.)	BC@.027	LF	.76	1.02	1.78
1/2" (.728 LF per fluid oz.)	BC@.030	LF	1.35	1.13	2.48
Polyurethane door, window & siding sealant, for installing or repairing door and window frames					
Gutter and flashing sealant, per ounce	—	Oz	.66	—	.66
1/8" (11.6 LF per fluid oz.)	BC@.018	LF	.06	.68	.74
1/4" (2.91 LF per fluid oz.)	BC@.022	LF	.23	.83	1.06

Ceiling, Suspended Panel

	Craft@Hrs	Unit	Material	Labor	Total
3/8" (1.29 LF per fluid oz.)	BC@.027	LF	.51	1.02	1.53
1/2" (.728 LF per fluid oz.)	BC@.030	LF	.90	1.13	2.03
Sanded caulk, comes in a variety of colors to match colored grout					
Sanded caulk, per ounce	—	Oz	.75	—	.75
1/8" (11.6 LF per fluid oz.)	BC@.018	LF	.06	.68	.74
1/4" (2.91 LF per fluid oz.)	BC@.022	LF	.26	.83	1.09
3/8" (1.29 LF per fluid oz.)	BC@.027	LF	.58	1.02	1.60
1/2" (.728 LF per fluid oz.)	BC@.030	LF	1.03	1.13	2.16
Tub and wall caulk strip, white, 1-5/8" x 11'					
Tub and wall sealant, per LF	BC@.025	LF	.40	.94	1.34
Caulking gun, professional type, heavy duty					
Cordless caulk gun	—	Ea	199.00	—	199.00
"Caulk Master" caulking gun	—	Ea	60.00	—	60.00
Caulking gun, economy grade					
1/10 gallon tube, ratchet rod	—	Ea	10.00	—	10.00
Quart capacity, smooth rod	—	Ea	22.00	—	22.00

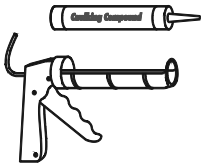

Cedar Closet Lining Material costs are per SF covered including 7% waste. Labor is for good quality installation in typical residential closet over studs or gypsum wallboard.

Solid cedar planks					
15 SF package	BC@.060	SF	2.26	2.26	4.52
35 SF package	BC@.060	SF	1.65	2.26	3.91

Ceiling Domes Complete ceiling dome kits, includes grid, hardware, panels and crating, from flat to 30 degree pitch in 5 degree increments. Prices shown are for best quality. Prices may be as much as 40% lower depending on the requirements. Envel Design Corp.

9' diameter	B1@10.7	Ea	6,040.00	365.00	6,405.00
10' diameter	B1@10.7	Ea	8,280.00	365.00	8,645.00
11' diameter	B1@17.2	Ea	10,900.00	587.00	11,487.00
UV stabilized commercial grade acrylic with decorative patterns (Costs vary from \$3.90 to \$6.50 per SF)					
Typical cost per SF	B1@.100	SF	6.42	3.41	9.83
Custom, dimensional Envellex™ Designs					
Standard sizes and patterns (2' x 2', 2' x 4')	B1@.006	SF	40.10	.20	40.30
Irregular shapes					
Oversize and custom designs	B1@.006	SF	47.00	.20	47.20
Add for cutting panels	B1@.033	Ea	—	1.13	1.13

Ceiling Panel Suspension Grids Typical costs, 15/16" flange, plain white. Add panel costs below.

Main runner, 12' long	—	Ea	11.10	—	11.10
Main runner, 12' long	—	LF	.92	—	.92
Cross tee, 2' long	—	Ea	2.00	—	2.00
Cross tee, 2' long	—	LF	1.00	—	1.00
Cross tee, 4' long	—	Ea	4.02	—	4.02
Cross tee, 4' long	—	LF	1.00	—	1.00
Wall mold, 12' long	—	Ea	6.64	—	6.64
Wall mold, 12' long	—	LF	.55	—	.55
Add for colored	—	%	10.0	—	—
Add for fire-rated white	—	%	100.0	—	—
Add for chrome or gold color grid	—	%	40.0	—	—
Suspension grid system including runners, tees, wall mold, hooks and hanging wire (but no tile or lighting fixtures)					
2' x 2' grid with wire suspension, per square foot					
15/16" flange	BC@.017	SF	1.16	.64	1.80
9/16" flange	BC@.015	SF	1.38	.56	1.94

Ceiling Panel Suspension Grids

	Craft@Hrs	Unit	Material	Labor	Total
15/16" flange, shadow molding	BC@.019	SF	1.30	.72	2.02
9/16" flange, shadow molding	BC@.017	SF	1.51	.64	2.15
2' x 2' grid suspended from black iron and pencil rod, per square foot					
15/16" flange	BC@.030	SF	1.96	1.13	3.09
9/16" flange	BC@.028	SF	2.19	1.05	3.24
15/16" flange, shadow molding	BC@.030	SF	1.98	1.13	3.11
9/16" flange, shadow molding	BC@.028	SF	2.23	1.05	3.28
2' x 4' grid with wire suspension, per square foot					
15/16" flange	BC@.015	SF	1.17	.56	1.73
9/16" flange	BC@.014	SF	1.38	.53	1.91
15/16" flange, shadow molding	BC@.017	SF	1.30	.64	1.94
2' x 4' grid suspended from black iron and pencil rod, per square foot					
15/16" flange	BC@.028	SF	1.82	1.05	2.87
9/16" flange	BC@.026	SF	2.06	.98	3.04
4' x 4' grid with wire suspension, per square foot					
15/16" flange	BC@.012	SF	.90	.45	1.35
Sheetrock grid system, wire suspended	BC@.015	SF	1.46	.56	2.02
Las Vegas code sub-lid grid	BC@.080	SF	1.54	3.01	4.55
Sub-ceiling grid suspended from black iron, Pencil rod and hat channel	BC@.020	SF	1.46	.75	2.21
Additional costs for suspension grid systems					
2-1/4" Compasso free form edge trim	BC@.050	LF	18.30	1.88	20.18
8" Axiom edge trim	BC@.060	LF	34.90	2.26	37.16
2" Axiom edge trim	BC@.060	LF	16.40	2.26	18.66
"L" trim	BC@.025	LF	1.64	.94	2.58
Add for small or irregular rooms	BC@.007	SF	—	.26	.26
Add for hold down clips	BC@.005	SF	.16	.19	.35
Serpentina wave curved grid	BC@3.00	SF	43.90	113.00	156.90
Troffer lighting fixtures for ceiling suspension grid, includes installation, connection, lens and tubes					
2 tube 2' x 2' fixture	BE@1.00	Ea	41.90	41.00	82.90
2 tube 2' x 4' fixture	BE@1.00	Ea	54.40	41.00	95.40
3 tube 2' x 4' fixture	BE@1.00	Ea	52.30	41.00	93.30
4 tube 2' x 4' fixture	BE@1.00	Ea	59.70	41.00	100.70
Light-diffusing panels for installation in suspension system under fluorescent lighting. Reduce per unit price by 10% for volume purchases.					
Styrene, assuming minimum quantity of 10					
.065" thick, cracked ice, 2' x 2', white	BC@.020	Ea	7.00	.75	7.75
.065" thick, cracked ice, 2' x 4', white	BC@.029	Ea	14.00	1.09	15.09
.095" thick, prismatic, 2' x 2', clear	BC@.020	Ea	8.09	.75	8.84
.095" thick, prismatic, 2' x 2', white	BC@.020	Ea	6.53	.75	7.28
.095" thick, prismatic, 2' x 4', clear	BC@.029	Ea	16.20	1.09	17.29
.095" thick, prismatic, 2' x 4', white	BC@.029	Ea	13.10	1.09	14.19
.095" thick, Victorian pattern 2' x 4'	BC@.029	Ea	39.30	1.09	40.39
Egg crate louvers, 1/2" x 1/2" x 3/8" cell size					
Frost	BC@.188	Ea	15.00	7.08	22.08
White styrene	BC@.188	Ea	21.00	7.08	28.08
Silver finish	BC@.188	Ea	71.20	7.08	78.28
Metallic styrene	BC@.188	Ea	80.60	7.08	87.68
Anodized aluminum	BC@.188	Ea	90.10	7.08	97.18

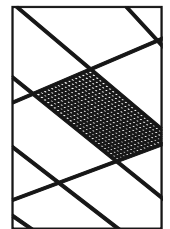

Ceiling Panels, Lay-in Type

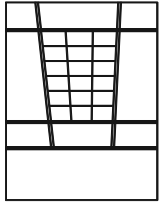

	Craft@Hrs	Unit	Material	Labor	Total
Parabolic louvers, 5/8" x 5/8" x 7/16" cell size					
Silver styrene	BC@.188	Ea	29.50	7.08	36.58
Gold styrene	BC@.188	Ea	31.10	7.08	38.18
Silver acrylic	BC@.188	Ea	50.30	7.08	57.38
Gold acrylic	BC@.188	Ea	50.30	7.08	57.38
Stained glass look, one dimension, 2' x 2'					
Standard colors	BC@.033	Ea	34.90	1.24	36.14
Antiqued colors	BC@.035	Ea	46.60	1.32	47.92

Ceiling Panels, Lay-in Type Costs per SF of ceiling area covered. No waste included. Add suspension grid system cost from preceding pages. Sound absorbing suspended ceiling panels. NRC is Noise Reduction Coefficient.



2' x 2' or 2' x 4' suspended white 5/8" ceiling panels (except as noted)					
Contractor Pack, White Fissured	BC@.012	SF	.60	.45	1.05
Cortega or Fissured, square edge	BC@.012	SF	.99	.45	1.44
Cortega or Fissured, beveled or angular tegular	BC@.012	SF	1.23	.45	1.68
Fine Fissured, square edge	BC@.012	SF	1.02	.45	1.47
Fine Fissured, beveled or angular tegular	BC@.012	SF	1.91	.45	2.36
Designer (rough textured), square edge	BC@.012	SF	1.22	.45	1.67
Kitchen Zone, moisture resistant, square edge	BC@.012	SF	1.35	.45	1.80
Designer (rough textured), angled tegular	BC@.012	SF	1.59	.45	2.04
Georgian, impact resistant, square edge	BC@.012	SF	1.62	.45	2.07
Shasta or Random Fissured, square edge	BC@.012	SF	1.69	.45	2.14
Dune, sound blocking, square edge	BC@.012	SF	1.70	.45	2.15
Georgian, impact resistant, beveled edge	BC@.012	SF	1.82	.45	2.27
Dune, sound blocking, angled or bevel edge	BC@.012	SF	1.85	.45	2.30
Pebble, cleanable, impact resistant, 1"	BC@.012	SF	2.00	.45	2.45
Mesa, sustainable, square edge	BC@.012	SF	2.14	.45	2.59
Mesa, sustainable, beveled edge	BC@.012	SF	2.43	.45	2.88
Ledges, single embossed square	BC@.012	SF	2.57	.45	3.02
Cirrus, colors, beveled or square edge, 3/4"	BC@.012	SF	3.16	.45	3.61
Ultima, high NRC, sustainable, cleanable, 7/8"	BC@.012	SF	3.62	.45	4.07
Ultima Health Zone, high NRC, cleanable, 7/8"	BC@.012	SF	4.54	.45	4.99
Calla, sustainable, white, 1"	BC@.012	SF	4.56	.45	5.01
Calla, sustainable, black, 1"	BC@.012	SF	6.95	.45	7.40
Optima, square edge, 3/4"	BC@.012	SF	4.89	.45	5.34
Optima Plant Based, 1"	BC@.012	SF	5.61	.45	6.06
Optima, angled or beveled edge, 3/4"	BC@.012	SF	5.63	.45	6.08
Optima, square edge, 1-1/2"	BC@.012	SF	5.75	.45	6.20
Optima, angled or beveled edge, 1-1/2"	BC@.012	SF	6.04	.45	6.49
Optima Health Zone, square edge, 1"	BC@.012	SF	5.81	.45	6.26
Optima Health Zone, tegular edge, 1"	BC@.012	SF	6.10	.45	6.55
Cerama Guard, fine textured, 1"	BC@.012	SF	5.92	.45	6.37

Ceiling Pans, Metal

	Craft@Hrs	Unit	Material	Labor	Total
Fiberglass reinforced 24" x 24" gypsum panels for T-bar systems. Weight is 3 to 4 pounds each, depending on pattern					
White painted finish	BC@.015	Ea	13.60	.56	14.16
Wood grain finish	BC@.020	Ea	27.10	.75	27.85
Ceiling Pans, Metal Flat, 2' x 2' pans					
Aluminum with concealed grid					
2' x 2' painted	BC@.083	SF	8.71	3.13	11.84
2' x 2' polished	BC@.083	SF	12.70	3.13	15.83
Stainless steel with concealed grid					
2' x 2', polished clear mirror	BC@.097	SF	19.30	3.65	22.95
Stainless steel with exposed grid					
2' x 2', polished clear mirror	BC@.074	SF	11.00	2.79	13.79
Ceiling Tile Class "C" panels for non-acoustical and non-fire rated applications. Tongue and groove 12" x 12" tile nailed, stapled or glued to ceilings or walls. Costs per SF covered including fasteners, trim and typical waste.					
12" x 12", Armstrong Sand Pebble	BC@.054	SF	1.20	2.03	3.23
12" x 12", Washable White, Impressions, Pinehurst	BC@.035	SF	1.72	1.32	3.04
12" x 12", Armstrong "Pinehurst" swirl pattern	BC@.036	SF	1.72	1.36	3.08
12" x 12", Wellington tin-look embossed	BC@.035	SF	2.10	1.32	3.42
12" x 12", Armstrong Fine Fissured	BC@.035	SF	2.20	1.32	3.52
12" x 12", USG white wood fiber	BC@.035	SF	1.85	1.32	3.17
12" x 12", USG "Tivoli"	BC@.035	SF	1.84	1.32	3.16
12" x 12", Armstrong "Grenoble"	BC@.035	SF	2.10	1.32	3.42
Ceilings, Tin look Various patterns					
Embossed panels					
2' x 2' square panels, cost each, unfinished	B1@.147	Ea	8.13	5.01	13.14
2' x 2' square panels, cost each, white	B1@.147	Ea	14.20	5.01	19.21
2' x 2' square panels, cost each, copper/gold	B1@.147	Ea	24.40	5.01	29.41
2' x 2' square panels, cost each, silver	B1@.147	Ea	20.30	5.01	25.31
2' x 2' square panels, cost each, faux	B1@.147	Ea	42.70	5.01	47.71
Embossed plates					
12" x 12" plates, cost per SF	B1@.042	SF	2.28	1.43	3.71
12" x 24" plates, cost per SF	B1@.040	SF	2.60	1.36	3.96
24" x 24" plates, cost per SF	B1@.037	SF	3.64	1.26	4.90
24" x 48" plates, cost per SF	B1@.035	SF	3.42	1.19	4.61
Cement See also Adhesives, Aggregates, and Concrete					
Portland cement, type I and II, 94 lb sack	—	Sa	12.90	—	12.90
Plastic cement, 94 lb sack	—	Sa	13.10	—	13.10
High early strength cement, 80 lb sack	—	Sa	5.67	—	5.67
White cement, 94 lb sack	—	Sa	29.20	—	29.20
Concrete mix, fast setting, 50 lb sack	—	Sa	5.57	—	5.57
Light-weight concrete, 2/3 CF sack	—	Sa	4.87	—	4.87
Masonry cement, type N, 70 lb sack	—	Sa	12.80	—	12.80
Mortar mix, 60 lb sack	—	Sa	6.06	—	6.06

Cleaning, Final

	Craft@Hrs	Unit	Material	Labor	Total
Non-shrink construction grout, 50 lb sack	—	Sa	17.00	—	17.00
Fiber-reinforced stucco mix, 90 lb sack	—	Sa	21.60	—	21.60
Plaster patch, 25 lb sack	—	Sa	19.70	—	19.70
Blacktop cold patch mix, 50 lb sack	—	Sa	13.40	—	13.40
Sand, 60 lb sack	—	Sa	5.57	—	5.57
Deduct for pallet quantities	—	%	-15.0	—	—
Cleaning, Final Interior surfaces, plumbing fixtures and windows. Includes removing construction debris and grime. Add for removing paint splatter or mastic. Work performed using hand tools and commercial non-toxic cleaning products or solvent. Use \$80.00 as a minimum job charge.					
Cabinets, per linear foot of cabinet face. Wall or base cabinet, (bathroom, kitchen or linen)					
Cleaned inside and outside	BL@.048	LF	.09	1.47	1.56
Add for polish, exposed surface only	BL@.033	LF	.07	1.01	1.08
Countertops, per linear foot of front, bathroom, family room or kitchen					
Marble, granite, laminated or composition	BL@.012	LF	.07	.37	.44
Tile, including grouted joints	BL@.020	LF	.09	.61	.70
Painted surfaces, wipe down by hand					
Base board, trim or molding	BL@.003	LF	.05	.09	.14
Cased openings, per side cleaned	BL@.060	Ea	.04	1.83	1.87
Ceilings, painted	BL@2.00	MSF	6.06	61.10	67.16
Walls, painted or papered	BL@1.50	MSF	6.06	45.80	51.86
Window sills	BL@.004	LF	.03	.12	.15
Doors, painted or stained					
Cleaned two sides, including casing	BL@.150	Ea	.11	4.58	4.69
Floors					
Hardwood floor, clean, wax and polish	BL@5.50	MSF	7.57	168.00	175.57
Mop floor	BL@1.25	MSF	.52	38.20	38.72
Vacuum carpet or sweep floor	BL@.650	MSF	—	19.90	19.90
Shampoo carpet	BL@3.30	MSF	4.54	101.00	105.54
Plumbing fixtures					
Bar sink, including faucet	BL@.285	Ea	.17	8.71	8.88
Bathtubs, including faucets & shower heads	BL@.560	Ea	.33	17.10	17.43
Kitchen sink, including faucets	BL@.375	Ea	.17	11.50	11.67
Lavatories, including faucets	BL@.375	Ea	.17	11.50	11.67
Toilets, including seat and tank	BL@.450	Ea	.17	13.70	13.87
Shower stalls, including walls, floor, ceiling, controls and shower head					
Three-sided	BL@1.80	Ea	.27	55.00	55.27
Add for glass doors	BL@.500	Ea	.09	15.30	15.39
Sliding glass doors, clean and polish both sides including cleaning of track and screen					
Up to 8' wide	BL@.650	Ea	.09	19.90	19.99
Over 8' wide	BL@.750	Ea	.14	22.90	23.04
Windows, clean and polish, inside and outside, first or second floors, per SF cleaned					
Sliding, casement or picture windows	BL@.003	SF	.02	.09	.11
Jalousie type	BL@.004	Ea	.02	.12	.14
Remove window screen, hose wash, replace	BL@.100	Ea	—	3.06	3.06
Typical final cleanup for new residential construction					
Per SF of floor (no glass cleaning)	BL@.004	SF	.13	.12	.25

Concrete

	Craft@Hrs	Unit	Material	Labor	Total
Clothesline Units					
Retractable type, 5-line, indoor-outdoor, one end is wall-mounted, lines retract into aluminum case					
Cost per unit as described	B1@.860	Ea	100.00	29.30	129.30
Two "T"-shaped galvanized steel pole, set in concrete					
4 prong (not including cost of concrete)	BL@1.91	Ea	120.00	58.40	178.40
Concrete mix, 60 lb sack	—	Sa	5.25	—	5.25
Umbrella-type, 8' galvanized steel center post, requires 10' x 10' area, folds for storage					
One post, set in concrete	BL@.885	Ea	70.00	27.00	97.00
Concrete mix, 60 lb sack	—	Sa	5.25	—	5.25
Columns and Porch Posts					
Colonial style round wood, standard cap and base, hemlock/pine.					
8" x 8'	B1@2.00	Ea	180.00	68.20	248.20
10" x 10'	B1@2.00	Ea	192.00	68.20	260.20
Add for fluted wood, either of above	—	Ea	32.50	—	32.50
Round aluminum, standard cap and base					
8" x 9'	B1@2.00	Ea	205.00	68.20	273.20
10" x 10'	B1@2.00	Ea	319.00	68.20	387.20
12" x 12'	B1@3.00	Ea	588.00	102.00	690.00
Add for ornamental wood cap, typical price	—	Ea	107.00	—	107.00
Add for ornamental aluminum cap, typical	—	Ea	77.40	—	77.40
Turncraft poly round columns					
8" x 8' fluted	B1@2.00	Ea	228.00	68.20	296.20
8" x 8' plain	B1@2.00	Ea	178.00	68.20	246.20
10" x 10' plain	B1@2.00	Ea	262.00	68.20	330.20
10" x 12' plain	B1@3.00	Ea	306.00	102.00	408.00
Add for cap	—	Ea	19.30	—	19.30
Add for base	—	Ea	24.80	—	24.80
Porch posts, clear laminated west coast hemlock, solid turned.					
3-1/4" x 8'	B1@1.04	Ea	127.00	35.50	162.50
4-1/4" x 8'	B1@1.18	Ea	200.00	40.20	240.20
5-1/4" x 8'	B1@1.28	Ea	260.00	43.70	303.70
Concrete Ready-mix delivered by truck. Typical prices for most cities. Includes delivery up to 20 miles for 10 CY or more, 3" to 4" slump. Material cost only, no placing or pumping included. See forming and finishing costs on the following pages.					
Footing and foundation concrete, 1-1/2" aggregate					
2,000 PSI, 4.8 sack mix	—	CY	126.00	—	126.00
2,500 PSI, 5.2 sack mix	—	CY	129.00	—	129.00
3,000 PSI, 5.7 sack mix	—	CY	131.00	—	131.00
3,500 PSI, 6.3 sack mix	—	CY	136.00	—	136.00
4,000 PSI, 6.9 sack mix	—	CY	140.00	—	140.00
Slab, sidewalk, and driveway concrete, 1" aggregate					
2,000 PSI, 5.0 sack mix	—	CY	128.00	—	128.00
2,500 PSI, 5.5 sack mix	—	CY	131.00	—	131.00
3,000 PSI, 6.0 sack mix	—	CY	133.00	—	133.00
3,500 PSI, 6.6 sack mix	—	CY	136.00	—	136.00
4,000 PSI, 7.1 sack mix	—	CY	138.00	—	138.00



Concrete

	Craft@Hrs	Unit	Material	Labor	Total
Pea gravel pump mix / grout mix, 3/8" aggregate					
2,000 PSI, 6.0 sack mix	—	CY	138.00	—	138.00
2,500 PSI, 6.5 sack mix	—	CY	140.00	—	140.00
3,000 PSI, 7.2 sack mix	—	CY	145.00	—	145.00
3,500 PSI, 7.9 sack mix	—	CY	149.00	—	149.00
5,000 PSI, 8.5 sack mix	—	CY	158.00	—	158.00
Fiber mesh integral concrete reinforcing, polypropylene fiber, add per cubic yard of concrete					
Short fiber polypropylene (slabs), add	—	CY	6.66	—	6.66
Long fiber polypropylene (structural), add	—	CY	9.35	—	9.35
Extra delivery costs for ready-mix concrete					
Add for delivery over 20 miles	—	Mile	10.20	—	10.20
Add for standby charge in excess of 5 minutes per CY delivered					
per minute of extra time	—	Ea	3.18	—	3.18
Add for less than 10 CY per load delivered	—	CY	55.80	—	55.80
Add for Saturday delivery, per CY	—	CY	8.93	—	8.93
Extra costs for non-standard aggregates					
Add for lightweight aggregate, typical	—	CY	58.60	—	58.60
Add for lightweight aggregate, pump mix	—	CY	61.20	—	61.20
Add for granite aggregate, typical	—	CY	9.19	—	9.19
Extra costs for non-standard mix additives					
High early strength 5 sack mix	—	CY	16.60	—	16.60
High early strength 6 sack mix	—	CY	22.00	—	22.00
Add for white cement (architectural)	—	CY	75.80	—	75.80
Add for 1% calcium chloride	—	CY	2.13	—	2.13
Add for chemical compensated shrinkage	—	CY	27.90	—	27.90
Add for super plasticized mix, 7" - 8" slump	—	%	8.0	—	—
Add for colored concrete, typical prices. The ready-mix supplier charges for cleanup of the ready-mix truck used for delivery of colored concrete. The usual practice is to provide one truck per day for delivery of all colored concrete for a particular job. Cost will be based on the quantity of pigment required. Pastels require one to two pounds of pigment per sack of cement. Greater color density may require up to five pounds of pigment per cubic yard. Cost per cubic yard based on a 5-sack mix and one pound of color per sack.					
Most colors (tan, brown, gray, beige)	—	CY	32.80	—	32.80
Green (requires white cement)	—	CY	59.50	—	59.50
Blue (requires white cement)	—	CY	180.00	—	180.00
White concrete pigment	—	CY	45.90	—	45.90
Colored concrete, truck cleanup, per day	—	LS	101.00	—	101.00

Concrete Expansion Joints Fiber or asphaltic-felt sided. Per linear foot

Wall (thickness)					
Depth	1/4"	3/8"	1/2"		
3" deep	.10	.18	.32		
3-1/2" deep	.11	.23	.40		
4" deep	.14	.24	.46		
6" deep	.15	.31	.44		
	Craft@Hrs	Unit	Material	Labor	Total
Labor to install concrete expansion joints					
3" to 6" width, 1/4" to 1/2" thick	B1@.030	LF	—	1.02	1.02

Concrete

	Craft@Hrs	Unit	Material	Labor	Total
Concrete Snap Ties Short end ties, price each based on cartons of 200.					
6" form	—	Ea	.62	—	.62
8" form	—	Ea	.70	—	.70
10" form	—	Ea	.81	—	.81
12" form	—	Ea	.84	—	.84
14" form	—	Ea	.83	—	.83
16" form	—	Ea	.87	—	.87
18" form	—	Ea	.90	—	.90
24" form	—	Ea	1.03	—	1.03
6" wedge form tie	—	Ea	.57	—	.57
8" wedge form tie	—	Ea	.60	—	.60
10" wedge form tie	—	Ea	.71	—	.71
12" wedge form tie	—	Ea	.86	—	.86
14" wedge form tie	—	Ea	.99	—	.99
16" wedge form tie	—	Ea	.61	—	.61
24" wedge form tie	—	Ea	3.19	—	3.19
Add for long end ties	—	%	12.0	—	—

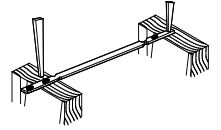

Concrete Form Stakes Steel, 3/8" thick x 1-1/2" wide. Costs per stake.					
18" x 1", flat	—	Ea	5.35	—	5.35
24" x 1", flat	—	Ea	5.70	—	5.70
30" x 1", flat	—	Ea	7.10	—	7.10
48" x 1", flat	—	Ea	10.90	—	10.90
12" x 1-1/2", flat	—	Ea	3.24	—	3.24
18" x 1-1/2", flat	—	Ea	5.60	—	5.60
24" x 1-1/2", flat	—	Ea	7.30	—	7.30
30" x 1-1/2", flat	—	Ea	7.04	—	7.04
36" x 1-1/2", flat	—	Ea	8.90	—	8.90
42" x 1-1/2", flat	—	Ea	7.92	—	7.92
48" x 1-1/2", flat	—	Ea	10.40	—	10.40
12" x 3/4", round	—	Ea	3.95	—	3.95
36" x 3/4", round	—	Ea	8.59	—	8.59
42" x 3/4", round	—	Ea	8.29	—	8.29
18" x 5/8", square	—	Ea	4.33	—	4.33
24" x 3/4", square	—	Ea	5.50	—	5.50
30" x 5/8", square	—	Ea	8.57	—	8.57
36" x 5/8", square	—	Ea	11.00	—	11.00
48" x 3/4", square	—	Ea	12.40	—	12.40

Insulated Concrete Forms (ICFs) Expanded polystyrene (EPS) forms for residential and commercial reinforced concrete walls 4", 6" or 8" thick. Based on standard sized block connected with plastic clips and reinforced with steel bars before cores are filled with concrete. Costs assume forms are left in place as wall insulation and that no concrete finishing is required. See www.concreteconstruction.net. The crew is a carpenter and a laborer. Material costs include EPS forms and connectors as described but no concrete or rebar.

Standard block, 5.3 SF per block

16" H, 48" L, with 12 panel connectors	—	Ea	22.00	—	22.00
--	---	----	-------	---	-------

Concrete Formwork

	Craft@Hrs	Unit	Material	Labor	Total
Corner blocks, each includes 8 panel connectors					
4" cavity, 16" H, 32" L	—	Ea	21.90	—	21.90
6" cavity, 16" H, 32" L	—	Ea	21.90	—	21.90
8" cavity, 16" H, 32" L	—	Ea	19.30	—	19.30
Connectors					
4" connectors, per box of 1000	—	Ea	227.00	—	227.00
6" connectors, per box of 500	—	Ea	113.00	—	113.00
8" connectors, per box of 500	—	Ea	113.00	—	113.00
10" connectors, per box of 500	—	Ea	113.00	—	113.00
Splice connectors, per box of 1000	—	Ea	102.00	—	102.00
Brick ledge rails, per box of 50 rails	—	Ea	51.40	—	51.40
1" extension "Texas T", per box of 500	—	Ea	47.00	—	47.00
16" 90 degree panel connectors, per box of 40	—	Ea	151.00	—	151.00
24" 90 degree panel connectors, per box of 40	—	Ea	189.00	—	189.00
16" 45 degree panel connectors, per box of 40	—	Ea	151.00	—	151.00
24" 45 degree panel connectors, per box of 40	—	Ea	189.00	—	189.00

Material and labor for EPS forms. These figures assume footings or concrete slab are in place and ready to accept the first course of forms. Material includes forms, connectors, rebar and concrete for a 6" wall. Labor includes erecting forms, setting rebar and pouring concrete in walls to 8' high. Assume that each square foot of wall requires 1 linear foot of #4 rebar.

Per square foot of wall, below grade	B1@.060	SF	5.95	2.05	8.00
Per standard block (5.3 SF), below grade	B1@.318	Ea	31.50	10.80	42.30
Per square foot of wall, above grade	B1@.080	SF	5.95	2.73	8.68
Per standard block (5.3 SF), above grade	B1@.424	Ea	31.50	14.50	46.00
Add for 8" walls	—	%	12.0	5.0	—
Deduct for 4" walls	—	%	-8.0	-5.0	—

Cement and expanded polystyrene forms Similar to EPS forms above but with cement added to the mix: Recycled polystyrene (85%) and concrete (15%) building blocks with a grid of internal chambers designed to be placed either horizontally or vertically. Available brands are Rastra Block and Grid-WALL. Once the panels are in place they are filled with concrete providing a high strength, fireproof structural grid. Includes cement filling and grouting. When cut for odd sizes use per sq ft pricing.

Material unit costs for Grid-WALL systems

Standard wall block, 5.3 SF per block					
48" L, 16" H,	—	Ea	32.70	—	32.70

Labor and material for wall construction

Material includes cost of Grid-WALL but not concrete or rebar. Labor includes stacking, leveling, adding rebar, bracing and prepping the wall but not the concrete pour.

Per square foot of wall	B1@.058	SF	6.19	1.98	8.17
Per standard block (5.3 SF)	B1@.313	Ea	32.70	10.70	43.40
Add to labor if concrete pour included	—	%	—	20.0	—

Use to calculate concrete and rebar costs:

1.1 cubic yards of concrete are required to fill 100 square feet of Grid-WALL.

1 Grid-WALL block will take 8 ft. of rebar, unless engineered otherwise.

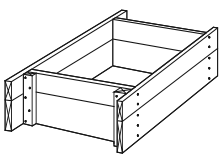

Concrete Formwork Multiple use of forms assumes that forms can be removed, partially disassembled and cleaned and that 75% of the form material can be reused. Costs include assembly, oiling, setting, stripping and cleaning. Material costs in this section can be adjusted to reflect your actual cost of lumber. Here's how: Divide your actual lumber cost per MBF by the assumed cost (listed in parentheses). Then multiply the cost in the material column by this adjustment factor. For expanded coverage of concrete and formwork, see the *National Concrete & Masonry Estimator* at <https://craftsman-book.com/national-estimator-cloud>.

Concrete Formwork

Craft@Hrs Unit Material Labor Total

Board forming and stripping For wall footings, grade beams, column footings, site curbs and steps. Includes 5% waste. Per SF of contact area. When forms are required on both sides of the concrete, include the contact surface for each side.

2" thick forms and bracing, using 2.85 BF of form lumber per SF. Includes nails, ties, and form oil

Using 2" lumber, per MBF	—	MBF	1,250.00	—	1,250.00
Using nails, ties and form oil, per SF	—	SF	.22	—	.22
1 use	B2@.115	SF	3.93	4.06	7.99
3 use	B2@.115	SF	1.80	4.06	5.86
5 use	B2@.115	SF	1.37	4.06	5.43
Add for keyway beveled on two edges, one use. No stripping included					
2" x 4"	B2@.027	LF	.86	.95	1.81
2" x 6"	B2@.027	LF	1.32	.95	2.27

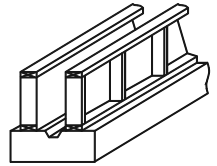
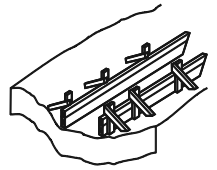

Driveway and walkway edge forms Material costs include stakes, nails, and form oil and 5% waste. Per LF of edge form. When forms are required on both sides of the concrete, include the length of each side plus the end widths.

2" x 4" edge form

Using 2" x 4" lumber, .7 BF per LF	—	MBF	1,240.00	—	1,240.00
Using nails, ties and form oil, per LF	—	LF	.22	—	.22
1 use	B2@.050	LF	1.03	1.76	2.79
3 use	B2@.050	LF	.55	1.76	2.31
5 use	B2@.050	LF	.45	1.76	2.21

2" x 6" edge form

Using 2" x 6" lumber, 1.05 BF per LF	—	MBF	1,260.00	—	1,260.00
1 use	B2@.050	LF	1.48	1.76	3.24
3 use	B2@.050	LF	.75	1.76	2.51
5 use	B2@.050	LF	.60	1.76	2.36

2" x 8" edge form

Using 2" x 8" lumber, 1.4 BF per LF	—	MBF	1,110.00	—	1,110.00
1 use	B2@.055	LF	1.80	1.94	3.74
3 use	B2@.055	LF	.90	1.94	2.84
5 use	B2@.055	LF	.70	1.94	2.64

2" x 10" edge form

Using 2" x 10" lumber, 1.75 BF per LF	—	MBF	1,180.00	—	1,180.00
1 use	B2@.055	LF	2.23	1.94	4.17
3 use	B2@.055	LF	1.09	1.94	3.03
5 use	B2@.055	LF	.84	1.94	2.78

2" x 12" edge form

Using 2" x 12" lumber, 2.1 BF per LF	—	MBF	1,350.00	—	1,350.00
1 use	B2@.055	LF	3.00	1.94	4.94
3 use	B2@.055	LF	1.44	1.94	3.38
5 use	B2@.055	LF	1.10	1.94	3.04

Plywood forming For foundation walls, building walls and retaining walls, using 3/4" plyform with 10% waste and 2" bracing with 20% waste. All material costs include nails, ties, clamps, form oil and stripping. Costs shown are per SF of contact area. When forms are required on both sides of the concrete, include the contact surface area for each side.

Using 3/4" plyform, per MSF	—	MSF	2,390.00	—	2,390.00
Using 2" bracing, per MBF	—	MBF	1,250.00	—	1,250.00
Using nails, ties, clamps & form oil, per SF	—	SFCA	.22	—	.22

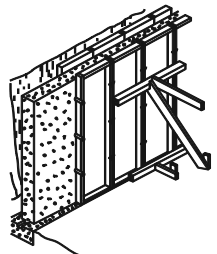

Concrete Formwork

	Craft@Hrs	Unit	Material	Labor	Total
Walls up to 4' high (1.10 SF of plywood and .42 BF of bracing per SF of form area)					
1 use	B2@.051	SFCA	3.37	1.83	5.20
3 use	B2@.051	SFCA	1.64	1.83	3.47
5 use	B2@.051	SFCA	1.26	1.83	3.09
Walls 4' to 8' high (1.10 SF of plywood and .60 BF of bracing per SF of form area)					
1 use	B2@.060	SFCA	3.59	2.16	5.75
3 use	B2@.060	SFCA	1.74	2.16	3.90
5 use	B2@.060	SFCA	1.33	2.16	3.49
Walls 8' to 12' high (1.10 SF of plywood and .90 BF of bracing per SF of form area)					
1 use	B2@.095	SFCA	3.97	3.41	7.38
3 use	B2@.095	SFCA	1.91	3.41	5.32
5 use	B2@.095	SFCA	1.46	3.41	4.87
Walls 12' to 16' high (1.10 SF of plywood and 1.05 BF of bracing per SF of form area)					
1 use	B2@.128	SFCA	4.15	4.60	8.75
3 use	B2@.128	SFCA	1.99	4.60	6.59
5 use	B2@.128	SFCA	1.52	4.60	6.12
Walls over 16' high (1.10 SF of plywood and 1.20 BF of bracing per SF of form area)					
1 use	B2@.153	SFCA	4.34	5.50	9.84
3 use	B2@.153	SFCA	2.07	5.50	7.57
5 use	B2@.153	SFCA	1.58	5.50	7.08

Form stripping Labor to remove forms and bracing, clean, and stack on the job site.

Board forms at wall footings, grade beams and column footings. Per SF of contact area

1" thick lumber	BL@.010	SFCA	—	.31	.31
2" thick lumber	BL@.012	SFCA	—	.37	.37
Keyways, 2" x 4" and 2" x 6"	BL@.006	LF	—	.18	.18
Slab edge forms. Per LF of edge form					
2" x 4" to 2" x 6"	BL@.012	LF	—	.37	.37
2" x 8" to 2" x 12"	BL@.013	LF	—	.40	.40
Walls, plywood forms. Per SF of contact area stripped					
To 4' high	BL@.017	SFCA	—	.52	.52
Over 4' to 8' high	BL@.018	SFCA	—	.55	.55
Over 8' to 12' high	BL@.020	SFCA	—	.61	.61
Over 12' to 16' high	BL@.027	SFCA	—	.82	.82
Over 16' high	BL@.040	SFCA	—	1.22	1.22

Concrete Reinforcing Steel reinforcing bars (rebar), ASTM A615 Grade 60. Material costs are for deformed steel reinforcing rebars, including 10% lap allowance, cutting and bending. These costs also include detailed shop drawings and delivery to jobsite with identity tags per shop drawings. Add for epoxy or galvanized coating of rebars, chairs, splicing, spiral caissons and round column reinforcing, if required, from the sections following the data below. Costs per pound (Lb) and per linear foot (LF) including tie wire and tying.

Reinforcing steel placed and tied in footings and grade beams

1/4" diameter, #2 rebar	RI@.015	Lb	1.51	.59	2.10
1/4" diameter, #2 rebar (.17 Lb per LF)	RI@.003	LF	.26	.12	.38
3/8" diameter, #3 rebar	RI@.011	Lb	1.03	.44	1.47
3/8" diameter, #3 rebar (.38 Lb per LF)	RI@.004	LF	.39	.16	.55
1/2" diameter, #4 rebar	RI@.010	Lb	.88	.40	1.28
1/2" diameter, #4 rebar (.67 Lb per LF)	RI@.007	LF	.59	.28	.87
5/8" diameter, #5 rebar	RI@.009	Lb	.94	.36	1.30

Concrete Reinforcing Steel

	Craft@Hrs	Unit	Material	Labor	Total
5/8" diameter, #5 rebar (1.04 Lb per LF)	RI@.009	LF	.98	.36	1.34
3/4" diameter, #6 rebar	RI@.008	Lb	.79	.32	1.11
3/4" diameter, #6 rebar (1.50 Lb per LF)	RI@.012	LF	1.19	.48	1.67
7/8" diameter, #7 rebar	RI@.008	Lb	.97	.32	1.29
7/8" diameter, #7 rebar (2.04 Lb per LF)	RI@.016	LF	1.97	.63	2.60
1" diameter, #8 rebar	RI@.008	Lb	.82	.32	1.14
1" diameter, #8 rebar (2.67 Lb per LF)	RI@.021	LF	2.19	.83	3.02
Reinforcing steel placed and tied in structural slabs					
1/4" diameter, #2 rebar	RI@.014	Lb	1.51	.56	2.07
1/4" diameter, #2 rebar (.17 Lb per LF)	RI@.002	LF	.26	.08	.34
3/8" diameter, #3 rebar	RI@.010	Lb	1.03	.40	1.43
3/8" diameter, #3 rebar (.38 Lb per LF)	RI@.004	LF	.39	.16	.55
1/2" diameter, #4 rebar	RI@.009	Lb	.88	.36	1.24
1/2" diameter, #4 rebar (.67 Lb per LF)	RI@.006	LF	.59	.24	.83
5/8" diameter, #5 rebar	RI@.008	Lb	.94	.32	1.26
5/8" diameter, #5 rebar (1.04 Lb per LF)	RI@.008	LF	.98	.32	1.30
3/4" diameter, #6 rebar	RI@.007	Lb	.79	.28	1.07
3/4" diameter, #6 rebar (1.50 Lb per LF)	RI@.011	LF	1.19	.44	1.63
7/8" diameter, #7 rebar	RI@.007	Lb	.97	.28	1.25
7/8" diameter, #7 rebar (2.04 Lb per LF)	RI@.014	LF	1.97	.56	2.53
1" diameter, #8 rebar	RI@.007	Lb	.82	.28	1.10
1" diameter, #8 rebar (2.67 Lb per LF)	RI@.019	LF	2.19	.75	2.94
Reinforcing steel placed and tied in walls					
1/4" diameter, #2 rebar	RI@.017	Lb	1.51	.67	2.18
1/4" diameter, #2 rebar (.17 Lb per LF)	RI@.003	LF	.26	.12	.38
3/8" diameter, #3 rebar	RI@.012	Lb	1.03	.48	1.51
3/8" diameter, #3 rebar (.38 Lb per LF)	RI@.005	LF	.39	.20	.59
1/2" diameter, #4 rebar	RI@.011	Lb	.88	.44	1.32
1/2" diameter, #4 rebar (.67 Lb per LF)	RI@.007	LF	.59	.28	.87
5/8" diameter, #5 rebar	RI@.010	Lb	.94	.40	1.34
5/8" diameter, #5 rebar (1.04 Lb per LF)	RI@.010	LF	.98	.40	1.38
3/4" diameter, #6 rebar	RI@.009	Lb	.79	.36	1.15
3/4" diameter, #6 rebar (1.50 Lb per LF)	RI@.014	LF	1.19	.56	1.75
7/8" diameter, #7 rebar	RI@.009	Lb	.97	.36	1.33
7/8" diameter, #7 rebar (2.04 Lb per LF)	RI@.018	LF	1.97	.71	2.68
1" diameter, #8 rebar	RI@.009	Lb	.82	.36	1.18
1" diameter, #8 rebar (2.67 Lb per LF)	RI@.024	LF	2.19	.95	3.14
Add for reinforcing steel coating. Coating applied prior to shipment to the job site. Labor for placing coated rebar is the same as that shown for plain rebar above. Cost per pound of reinforcing steel.					
Epoxy coating					
Any size rebar, add	—	Lb	.41	—	.41
Galvanized coating					
Any #2 rebar, #3 rebar or #4 rebar, add	—	Lb	.53	—	.53
Any #5 rebar or #6 rebar, add	—	Lb	.50	—	.50
Any #7 rebar or #8 rebar, add	—	Lb	.47	—	.47
Add for reinforcing steel chairs. Labor for placing rebar shown above includes time for setting chairs.					
Chairs, individual type, cost each					
3" high					
Steel	—	Ea	.87	—	.87
Plastic	—	Ea	.32	—	.32
Galvanized steel	—	Ea	1.59	—	1.59

Concrete Reinforcing Steel

	Craft@Hrs	Unit	Material	Labor	Total
5" high					
Steel	—	Ea	1.33	—	1.33
Plastic	—	Ea	.83	—	.83
Galvanized steel	—	Ea	2.09	—	2.09
8" high					
Steel	—	Ea	2.83	—	2.83
Plastic	—	Ea	1.69	—	1.69
Galvanized steel	—	Ea	4.48	—	4.48
Chairs, continuous type, with legs 8" OC, cost per linear foot					
3" high					
Steel	—	LF	1.21	—	1.21
Plastic	—	LF	.68	—	.68
Galvanized steel	—	LF	1.85	—	1.85
6" high					
Steel	—	LF	1.67	—	1.67
Plastic	—	LF	.95	—	.95
Galvanized steel	—	LF	2.62	—	2.62
8" high					
Steel	—	LF	2.56	—	2.56
Plastic	—	LF	1.75	—	1.75
Galvanized steel	—	LF	3.68	—	3.68
Waterstop, 3/8", adhesive not included.					
Rubber, 6"	B2@.059	LF	1.45	2.12	3.57
Rubber, 9"	B2@.059	LF	3.14	2.12	5.26

Spiral caisson and round column reinforcing 3/8" diameter hot rolled steel spirals with main vertical bars as shown. Costs include typical engineering and shop drawings. Based on shop fabricated spirals delivered, tagged, ready to install. Cost per vertical linear foot (VLF)

16" diameter with 6 #6 bars, 16.8 Lbs per VLF	RI@.041	VLF	52.30	1.63	53.93
24" diameter with 6 #6 bars, 28.5 Lbs per VLF	RI@.085	VLF	89.30	3.37	92.67
36" diameter with 8 #10 bars, 51.2 Lbs per VLF	RI@.176	VLF	163.00	6.98	169.98

Welded wire mesh Steel, electric weld, including 15% waste and overlap

2" x 2" W.9 x W.9 (#12 x #12), slabs	RI@.004	SF	1.40	.16	1.56
2" x 2" W.9 x W.9 (#12 x #12), beams and columns	RI@.020	SF	1.40	.79	2.19
4" x 4" W1.4 x W1.4 (#10 x #10), slabs	RI@.003	SF	.67	.12	.79
4" x 4" W2.0 x W2.0 (#8 x #8), slabs	RI@.004	SF	.78	.16	.94
4" x 4" W2.9 x W2.9 (#6 x #6), slabs	RI@.005	SF	.87	.20	1.07
4" x 4" W4.0 x W4.0 (#4 x #4), slabs	RI@.006	SF	1.16	.24	1.40
6" x 6" W1.4 x W1.4 (#10 x #10), slabs	RI@.003	SF	.29	.12	.41
6" x 6" W2.0 x W2.0 (#8 x #8), slabs	RI@.004	SF	.52	.16	.68
6" x 6" W2.9 x W2.9 (#6 x #6), slabs	RI@.004	SF	.60	.16	.76
6" x 6" W4.0 x W4.0 (#4 x #4), slabs	RI@.005	SF	.82	.20	1.02
Add for lengthwise cut, LF of cut	RI@.002	LF	—	.08	.08

Welded wire mesh, galvanized steel, electric weld, including 15% waste and overlap

2" x 2" W.9 x W.9 (#12 x #12), slabs	RI@.004	SF	2.83	.16	2.99
4" x 4" W1.4 x W1.4 (#10 x #10), slabs	RI@.003	SF	1.32	.12	1.44
4" x 4" W2.0 x W2.0 (#8 x #8), slabs	RI@.004	SF	1.59	.16	1.75
4" x 4" W2.9 x W2.9 (#6 x #6), slabs	RI@.005	SF	1.75	.20	1.95
4" x 4" W4.0 x W4.0 (#4 x #4), slabs	RI@.006	SF	2.29	.24	2.53
6" x 6" W1.4 x W1.4 (#10 x #10), slabs	RI@.003	SF	.74	.12	.86

Concrete Walls

	Craft@Hrs	Unit	Material	Labor	Total
6" x 6" W2.0 x W2.0 (#8 x #8), slabs	Rl@.004	SF	.91	.16	1.07
6" x 6" W2.9 x W2.9 (#6 x #6), slabs	Rl@.004	SF	1.16	.16	1.32
6" x 6" W4.0 x W4.0 (#4 x #4), slabs	Rl@.005	SF	1.67	.20	1.87
Add for lengthwise cut, LF of cut	Rl@.002	LF	—	.08	.08
Welded wire mesh, epoxy coated steel, electric weld, including 15% waste and overlap					
2" x 2" W.9 x W.9 (#12 x #12), slabs	Rl@.004	SF	5.82	.16	5.98
4" x 4" W1.4 x W1.4 (#10 x #10), slabs	Rl@.003	SF	4.20	.12	4.32
4" x 4" W2.0 x W2.0 (#8 x #8), slabs	Rl@.004	SF	5.16	.16	5.32
4" x 4" W2.9 x W2.9 (#6 x #6), slabs	Rl@.005	SF	5.25	.20	5.45
4" x 4" W4.0 x W4.0 (#4 x #4), slabs	Rl@.006	SF	5.52	.24	5.76
6" x 6" W1.4 x W1.4 (#10 x #10), slabs	Rl@.003	SF	4.74	.12	4.86
6" x 6" W2.0 x W2.0 (#8 x #8), slabs	Rl@.004	SF	4.84	.16	5.00
6" x 6" W2.9 x W2.9 (#6 x #6), slabs	Rl@.004	SF	4.92	.16	5.08
6" x 6" W4.0 x W4.0 (#4 x #4), slabs	Rl@.005	SF	5.20	.20	5.40
Add for lengthwise cut, LF of cut	Rl@.002	LF	—	.08	.08

Concrete Walls Cast-in-place concrete walls for buildings or retaining walls. Material costs for concrete placed direct from chute are based on 2,000 PSI, 5.0 sack mix, with 1" aggregate, including 5% waste. Pump mix costs include an additional \$15.00 per CY for the pump. Labor costs are for placing only. Add the cost of excavation, formwork, steel reinforcing, finishes and curing. Square foot costs are based on SF of wall measured on one face only. Costs do not include engineering, design or foundations. For expanded coverage of concrete and formwork, see the *National Concrete & Masonry Estimator* at <https://craftsman-book.com/national-estimator-cloud>.

Using concrete (before 5% waste allowance)	—	CY	128.00	—	128.00
4" thick walls (1.23 CY per CSF)					
To 4' high, direct from chute	B1@.013	SF	1.65	.44	2.09
4' to 8' high, pumped	B3@.015	SF	1.84	.49	2.33
8' to 12' high, pumped	B3@.017	SF	1.84	.56	2.40
12' to 16' high, pumped	B3@.018	SF	1.84	.59	2.43
16' high, pumped	B3@.020	SF	1.84	.66	2.50
6" thick walls (1.85 CY per CSF)					
To 4' high, direct from chute	B1@.020	SF	2.48	.68	3.16
4' to 8' high, pumped	B3@.022	SF	2.76	.72	3.48
8' to 12' high, pumped	B3@.025	SF	2.76	.82	3.58
12' to 16' high, pumped	B3@.027	SF	2.76	.89	3.65
16' high, pumped	B3@.030	SF	2.76	.99	3.75
8" thick walls (2.47 CY per CSF)					
To 4' high, direct from chute	B1@.026	SF	3.31	.89	4.20
4' to 8' high, pumped	B3@.030	SF	3.69	.99	4.68
8' to 12' high, pumped	B3@.033	SF	3.69	1.09	4.78
12' to 16' high, pumped	B3@.036	SF	3.69	1.19	4.88
16' high, pumped	B3@.040	SF	3.69	1.32	5.01
10" thick walls (3.09 CY per CSF)					
To 4' high, direct from chute	B1@.032	SF	4.15	1.09	5.24
4' to 8' high, pumped	B3@.037	SF	4.61	1.22	5.83
8' to 12' high, pumped	B3@.041	SF	4.61	1.35	5.96
12' to 16' high, pumped	B3@.046	SF	4.61	1.51	6.12
16' high, pumped	B3@.050	SF	4.61	1.65	6.26
12" thick walls (3.70 CY per CSF)					
To 4' high, placed direct from chute	B1@.040	SF	4.97	1.36	6.33
4' to 8' high, pumped	B3@.045	SF	5.52	1.48	7.00
8' to 12' high, pumped	B3@.050	SF	5.52	1.65	7.17
12' to 16' high, pumped	B3@.055	SF	5.52	1.81	7.33
16' high, pumped	B3@.060	SF	5.52	1.98	7.50

Concrete Footings

Concrete Footings, Grade Beams and Stem Walls Use the figures below for preliminary estimates. Concrete costs are based on 2,000 PSI, 5.0 sack mix with 1" aggregate placed directly from the chute of a ready-mix truck. Figures in parentheses show the cubic yards of concrete per linear foot of foundation (including 5% waste). Costs shown include concrete, 60 pounds of reinforcing per CY of concrete, and typical excavation using a 3/4 CY backhoe with excess backfill spread on site.

Footings and grade beams Cast directly against the earth, no forming or finishing required. These costs assume the top of the foundation will be at finished grade. For scheduling purposes estimate that a crew of 3 can lay out, excavate, place and tie the reinforcing steel and place 13 CY of concrete in an 8-hour day. Use \$900.00 as a minimum job charge.

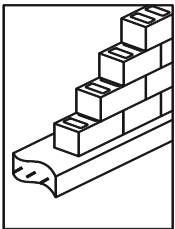

	Craft@Hrs	Unit	Material	Labor	Equipment	Total
Using 2,000 PSI concrete, per CY	—	CY	128.00	—	—	128.00
Using #4 reinforcing bars, per pound	—	Lb	.88	—	—	.88
Typical cost per CY	B4@1.80	CY	181.00	68.00	27.10	276.10
12" W x 6" D (0.019 CY per LF)	B4@.034	LF	3.44	1.28	.51	5.23
12" W x 8" D (0.025 CY per LF)	B4@.045	LF	4.52	1.70	.68	6.90
12" W x 10" D (0.032 CY per LF)	B4@.058	LF	5.79	2.19	.87	8.85
12" W x 12" D (0.039 CY per LF)	B4@.070	LF	7.05	2.64	1.06	10.75
12" W x 18" D (0.058 CY per LF)	B4@.104	LF	10.50	3.93	1.57	16.00
16" W x 8" D (0.035 CY per LF)	B4@.063	LF	6.33	2.38	.95	9.66
16" W x 10" D (0.043 CY per LF)	B4@.077	LF	7.77	2.91	1.16	11.84
16" W x 12" D (0.052 CY per LF)	B4@.094	LF	9.40	3.55	1.42	14.37
18" W x 8" D (0.037 CY per LF)	B4@.067	LF	6.69	2.53	1.01	10.23
18" W x 10" D (0.049 CY per LF)	B4@.088	LF	8.86	3.32	1.33	13.51
18" W x 24" D (0.117 CY per LF)	B4@.216	LF	21.20	8.16	3.26	32.62
20" W x 12" D (0.065 CY per LF)	B4@.117	LF	11.80	4.42	1.76	17.98
24" W x 12" D (0.078 CY per LF)	B4@.140	LF	14.10	5.29	2.11	21.50
24" W x 24" D (0.156 CY per LF)	B4@.281	LF	28.20	10.60	4.24	43.04
24" W x 30" D (0.195 CY per LF)	B4@.351	LF	35.30	13.30	5.29	53.89
24" W x 36" D (0.234 CY per LF)	B4@.421	LF	42.30	15.90	6.35	64.55
30" W x 36" D (0.292 CY per LF)	B4@.526	LF	52.80	19.90	7.93	80.63
30" W x 42" D (0.341 CY per LF)	B4@.614	LF	61.70	23.20	9.26	94.16
36" W x 48" D (0.467 CY per LF)	B4@.841	LF	84.40	31.80	12.70	128.90

Tricks of the trade: To estimate the cost of footing or grade beam sizes not shown, multiply the width in inches by the depth in inches and divide the result by 3700. This is the CY of concrete per LF of footing including 5% waste. Multiply by the "Typical cost per CY" in the prior table to find the cost per LF.

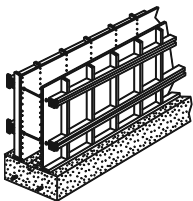

Continuous concrete footing with foundation stem wall These figures assume the foundation stem wall projects 24" above the finished grade and extends into the soil 18" to the top of the footing. Costs shown include typical excavation using a 3/4 CY backhoe with excess backfill spread on site, forming both sides of the foundation wall and the footing, based on three uses of the forms and 2 #4 rebar. Use \$1,200.00 as a minimum cost for this type work.

Typical cost per CY	B5@7.16	CY	217.00	268.00	64.80	549.80
Typical single story structure, footing 12" W x 8" D, wall 6" T x 42" D (.10 CY per LF)	B5@.716	LF	21.70	26.80	6.48	54.98
Typical two story structure, footing 18" W x 10" D, wall 8" T x 42" D (.14 CY per LF)	B5@1.00	LF	30.40	37.40	9.04	76.84
Typical three story structure, footing 24" W x 12" D, wall 10" T x 42" D (.19 CY per LF)	B5@1.36	LF	41.20	50.80	12.30	104.30

Concrete Slabs

Craft@Hrs Unit Material Labor Total

Column Footings Concrete material and placing only. Material costs are for 3,000 PSI, 5.7 sack mix, with 1-1/2" aggregate with 5% waste included. Labor cost is for placing concrete in an existing form. Add for excavation, board forming and steel reinforcing.

Using concrete (before waste allowance)	—	CY	132.00	—	132.00
Typical cost per CY	B1@.875	CY	139.00	29.80	168.80

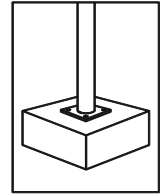

Slabs, Walks and Driveways Typical costs for reinforced concrete slabs-on-grade including fine grading, slab base, forms, vapor barrier, wire mesh, 3,000 PSI concrete, finishing and curing. For expanded coverage of concrete and formwork, see the *National Concrete & Masonry Estimator* at <https://craftsman-book.com/national-estimator-cloud>. For thickened edge slabs, add the area of the thickened edge. Use 500 square feet as a minimum.

2" thick	B5@.067	SF	2.37	2.50	4.87
3" thick	B5@.068	SF	2.78	2.54	5.32
4" thick	B5@.069	SF	3.19	2.58	5.77
5" thick	B5@.070	SF	3.60	2.62	6.22
6" thick	B5@.071	SF	4.01	2.65	6.66

Slab base Aggregate base for slabs. No waste included. Labor costs are for spreading aggregate from piles only. Add for fine grading, using hand tools.

Crushed stone base 1.4 tons equal 1 cubic yard

Using crushed stone, per CY	—	CY	33.80	—	33.80
1" base (.309 CY per CSF)	BL@.001	SF	.10	.03	.13
2" base (.617 CY per CSF)	BL@.003	SF	.21	.09	.30
3" base (.926 CY per CSF)	BL@.004	SF	.31	.12	.43
4" base (1.23 CY per CSF)	BL@.006	SF	.42	.18	.60
5" base (1.54 CY per CSF)	BL@.007	SF	.52	.21	.73
6" base (1.85 CY per CSF)	BL@.008	SF	.63	.24	.87

Sand fill base 1.40 tons equal 1 cubic yard

Using sand, per CY	—	CY	39.00	—	39.00
1" fill (.309 CY per CSF)	BL@.001	SF	.12	.03	.15
2" fill (.617 CY per CSF)	BL@.002	SF	.24	.06	.30
3" fill (.926 CY per CSF)	BL@.003	SF	.36	.09	.45
4" fill (1.23 CY per CSF)	BL@.004	SF	.48	.12	.60
5" fill (1.54 CY per CSF)	BL@.006	SF	.60	.18	.78
6" fill (1.85 CY per CSF)	BL@.007	SF	.72	.21	.93
Add for fine grading for slab on grade	BL@.008	SF	—	.24	.24

Slab membrane Material costs are for 10' wide membrane with 6" laps. Labor costs are to lay membrane over a level slab base.

4 mil polyethylene	BL@.002	SF	.08	.06	.14
6 mil polyethylene	BL@.002	SF	.10	.06	.16
Detaching membrane, Ditra, polyethylene laminate, SF costs include 5% waste					
Laid on a level slab	BL@.002	SF	1.66	.06	1.72
Add for adhesive cemented seams	BL@.001	SF	.07	.03	.10

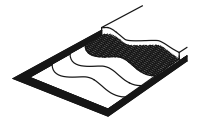

Concrete Finishing

Craft@Hrs Unit Material Labor Total

Curbs and gutters Small quantities. Material costs are for 2,000 PSI, 5.0 sack mix with 1" aggregate. No waste included. Labor cost is for placing and finishing concrete only. Add for excavation, wood forming, steel reinforcing.

Per CY of concrete B6@1.61 CY 128.00 53.50 181.50

Steps-on-grade Costs include layout, fabrication, and placing forms, setting and tying steel reinforcing, installation of steel nosing, placing 2,000 PSI concrete directly from the chute of a ready-mix truck, finishing, stripping forms, and curing. Costs assume excavation, back filling, and compacting have been completed. For scheduling purposes, estimate that a crew of 3 can set forms, place steel, and pour 4 to 5 CY of concrete cast-in-place steps in an 8 hour day. See also Cast-in-place Concrete Steps-on-Grade in the Industrial Section 3. Costs shown are for concrete steps with a 6" rise height and 12" tread depth supported by a 6" thick monolithic slab.

Total cost of steps per CY of concrete B1@5.43 CY 424.00 185.00 609.00



Concrete Finishing

Slab finishes

Broom finish	B6@.012	SF	—	.40	.40
Float finish	B6@.010	SF	—	.33	.33
Trowel finishing					
Steel, machine work	B6@.015	SF	—	.50	.50
Steel, hand work	B6@.018	SF	—	.60	.60

Finish treads and risers

No abrasives, no plastering, per LF of tread	B6@.042	LF	—	1.40	1.40
With abrasives, plastered, per LF of tread	B6@.063	LF	.79	2.09	2.88
Scoring concrete surface, hand work	B6@.005	LF	—	.17	.17
Sweep, scrub and wash down	B6@.006	SF	.04	.20	.24

Liquid curing and sealing compound, water-based Acrylic Concrete Cure and Seal, spray-on, 500 SF at \$110.00 per 5 gallon

B6@.003 SF .11 .10 .21

Exposed aggregate (washed, including finishing), no disposal of slurry

B6@.017 SF .16 .56 .72

Non-metallic color and hardener, troweled on, 2 applications, red, gray or black

60 pounds per 100 SF	B6@.021	SF	.74	.70	1.44
100 pounds per 100 SF	B6@.025	SF	1.24	.83	2.07
Add for non standard colors	—	%	27.3	—	—

Wall finishes

Snap ties and patch	B6@.011	SF	.16	.37	.53
Remove fins	B6@.008	LF	.05	.27	.32
Grind smooth, typical	B6@.021	SF	.10	.70	.80
Burlap rub with cement grout	B6@.022	SF	.06	.73	.79
Bush hammer green concrete	B6@.061	SF	.05	2.03	2.08
Bush hammer cured concrete	B6@.091	SF	.07	3.02	3.09
Wash with acid and rinse	B6@.004	SF	.24	.13	.37
Break fins, patch voids, Carborundum dry rub	B6@.035	SF	.07	1.16	1.23
Carborundum wet rub	B6@.057	SF	.15	1.89	2.04

Specialty finishes

Monolithic natural aggregate topping					
3/16"	B6@.020	SF	.63	.66	1.29
1/2"	B6@.022	SF	1.60	.73	2.33

Countertops

	Craft@Hrs	Unit	Material	Labor	Total
Integral colors					
Various colors, 10 oz. bottle	—	Ea	7.32	—	7.32
Colored release agent	—	Lb	2.72	—	2.72
Dry shake colored hardener	—	Lb	.60	—	.60
Stamped finish (embossed concrete) including touch-up of joints, if required					
Diamond, square, octagonal patterns	B6@.047	SF	—	1.56	1.56
Spanish paver pattern	B6@.053	SF	—	1.76	1.76
Add for grouting joints	B6@.023	SF	.39	.76	1.15

Countertops Custom-fabricated straight, "U"- or "L"-shaped tops. See also Tile for ceramic tile countertops.



Laminated plastic countertops (such as Formica, Textolite or Wilsonart) on a particleboard base. 22" to 25" wide. Cost per LF of longest edge (either back or front) in solid colors with 3-1/2" to 4" backsplash.

Square edge, separate backsplash	B1@.181	LF	17.80	6.17	23.97
Rolled drip edge (post formed)	B1@.181	LF	25.60	6.17	31.77
Full wrap (180 degree) front edge	B1@.181	LF	27.30	6.17	33.47
Accent color front edge	B1@.181	LF	34.70	6.17	40.87
Inlaid front and back edge	B1@.181	LF	40.90	6.17	47.07
Additional costs for laminated countertops					
Add for textures, patterns	—	%	20.0	—	—
Add for square end splash	—	Ea	21.60	—	21.60
Add for contour end splash	—	Ea	31.10	—	31.10
Add for mitered corners	—	Ea	25.80	—	25.80
Add for seamless tops	—	Ea	37.20	—	37.20
Add for sink, range or vanity cutout	—	Ea	10.00	—	10.00
Add for drilling 3 plumbing fixture holes	—	LS	12.80	—	12.80
Add for quarter round corner	—	Ea	25.90	—	25.90
Add for half round corner	—	Ea	37.00	—	37.00

Granite countertops, custom made to order from a template. 22" to 25" wide. Per square foot of top and backsplash, not including cutting, polishing, sink cut out, range cut out and a flat polish edge. Add the cost of edge polishing for undermount sink, faucet holes, angle cuts, radius ends, edge detail and jobsite delivery as itemized below. 7/8" granite weighs about 30 pounds per square foot. 1-1/4" granite weighs about 45 pounds per square foot. 7/8" tops should be set on 3/4" plywood and set in silicon adhesive every 2'. 1-1/4" granite tops can be set directly on base cabinets with silicon adhesive.

Most 3/4" (2cm) granite tops	B1@.128	SF	53.70	4.37	58.07
Most 1-1/4" (3cm) granite tops	B1@.128	SF	70.00	4.37	74.37
Add for radius or beveled edge	—	LF	9.62	—	9.62
Add for half bullnose edge	—	LF	13.80	—	13.80
Add for full bullnose edge	—	LF	27.50	—	27.50
Add for 1/2" beveled edge	—	LF	9.62	—	9.62
Add for backsplash seaming and edging	—	LF	17.70	—	17.70
Add for cooktop overmount cutout	—	Ea	178.00	—	178.00
Add for delivery (typical)	—	Ea	207.00	—	207.00
Add for eased edge	—	LF	6.88	—	6.88
Add for electrical outlet cutout	—	Ea	48.40	—	48.40
Add for faucet holes	—	Ea	36.20	—	36.20
Add for rounded corners	—	Ea	41.50	—	41.50
Add for undermount sink, polished	—	Ea	412.00	—	412.00

Engineered stone countertops, quartz particles with acrylic or epoxy binder. Trade names include Crystalite, Silestone and Cambria. Custom made from a template. Per square foot of top and backsplash surface measured one side.

Small light chips, 3/4" square edge	B1@.128	SF	64.80	4.37	69.17
Large dark chips, 3/4" square edge	B1@.128	SF	72.80	4.37	77.17

Cupolas

	Craft@Hrs	Unit	Material	Labor	Total
Add for 3/4" bullnose edge	—	LF	33.20	—	33.20
Add for 3/4" ogee edge	—	LF	43.50	—	43.50
Add for 1-1/2" bullnose edge	—	LF	63.40	—	63.40
Add for 1-1/2" ogee edge	—	LF	111.00	—	111.00
Add for sink cutout	—	Ea	332.00	—	332.00
Add for electrical outlet cutout	—	Ea	39.60	—	39.60
Add for radius corner or end	—	Ea	246.00	—	246.00
Add for delivery	—	Ea	199.00	—	199.00
Cultured stone vanity tops with integral back splash and sink, 22" deep					
Cultured marble					
24" long	B1@2.60	Ea	415.00	88.70	503.70
36" long	B1@2.60	Ea	536.00	88.70	624.70
48" long	B1@2.60	Ea	656.00	88.70	744.70
Cultured onyx					
24" long	B1@3.42	Ea	560.00	117.00	677.00
36" long	B1@3.42	Ea	718.00	117.00	835.00
48" long	B1@3.42	Ea	872.00	117.00	989.00
Corian vanity tops and integral sink, 1/2" thick, 22" deep. Series 100 includes matching integrated bowls. Series 300 has a solid bowl with different deck colors					
Series 100					
25" long	B1@.654	Ea	484.00	22.30	506.30
31" long	B1@.742	Ea	558.00	25.30	583.30
37" long	B1@.830	Ea	635.00	28.30	663.30
43" long	B1@.924	Ea	711.00	31.50	742.50
49" long	B1@1.02	Ea	802.00	34.80	836.80
Series 300					
25" long	B1@.654	Ea	651.00	22.30	673.30
31" long	B1@.742	Ea	679.00	25.30	704.30
37" long	B1@.830	Ea	802.00	28.30	830.30
43" long	B1@.924	Ea	878.00	31.50	909.50
49" long	B1@1.02	Ea	967.00	34.80	1,001.80
All side splashes, 22" L	B1@.314	Ea	38.90	10.70	49.60

Cupolas Add the cost of weather vanes below. Estimate the delivery cost at \$75 to \$100 per unit.

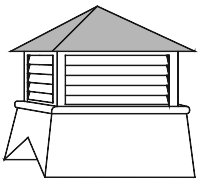

White vinyl with copper roof covering					
18" square base x 22-1/2" high	B1@.948	Ea	691.00	32.30	723.30
22" square base x 27-1/2" high	B1@.948	Ea	707.00	32.30	739.30
26" square base x 32-1/2" high	B1@1.43	Ea	924.00	48.80	972.80
32" square base x 40" high	B1@2.02	Ea	1,460.00	68.90	1,528.90
White pine with copper roof covering					
18" square base x 22-1/2" high	B1@.948	Ea	609.00	32.30	641.30
22" square base x 27-1/2" high	B1@.948	Ea	674.00	32.30	706.30
26" square base x 32-1/2" high	B1@1.43	Ea	821.00	48.80	869.80
30" square base x 37-1/2" high	B1@2.02	Ea	992.00	68.90	1,060.90
Weather vanes for cupolas					
Standard aluminum, baked black finish					
30" long	B1@.275	Ea	72.00	9.38	81.38
Deluxe model, gold-bronze finish aluminum					
46" long, ornamental	B1@.368	Ea	289.00	12.60	301.60

Decks

Craft@Hrs Unit Material Labor Total

Decks These costs assume 5/4" x 6" southern yellow pine decking, 2" x 8" redwood decking, 5/4" x 6" recycled plastic lumber decking or 2" x 8" recycled composite lumber decking supported by #2 & better 2" x 8" pressure treated joists spaced 24" on center over 4" x 8" pressure treated beams. Beams are supported by 4" x 4" pressure treated posts set 6' on center in concrete. Post length is assumed to be 2' above grade. Fasteners are 16d galvanized nails, galvanized steel joist hangers and post anchors. Decking is spaced at 1/8" to permit drainage. Costs are based on a rectangular deck, with one side fastened to an existing structure. Larger decks will reduce labor costs per square foot. Where better support is required, add the cost of round concrete forms (Sonotubes) and additional framing fasteners. Deck 3' above ground level with joists, beams, posts and hardware as described above and with decking material as shown.

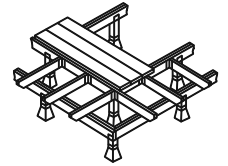

10' x 45'

Pine, pressure treated decking	B1@.170	SF	7.55	5.80	13.35
Redwood, select heart decking	B1@.170	SF	10.70	5.80	16.50
5/4" x 6" recycled composite lumber decking	B1@.225	SF	11.50	7.67	19.17
2" x 8" recycled composite lumber decking	B1@.225	SF	18.40	7.67	26.07

15' x 45'

Pine, pressure treated decking	B1@.170	SF	6.74	5.80	12.54
Redwood, select heart decking	B1@.170	SF	9.92	5.80	15.72
5/4" x 6" recycled composite lumber decking	B1@.225	SF	10.70	7.67	18.37
2" x 8" recycled composite lumber decking	B1@.225	SF	17.60	7.67	25.27

15' x 65'

Pine, pressure treated decking	B1@.170	SF	6.81	5.80	12.61
Redwood, select heart decking	B1@.170	SF	9.99	5.80	15.79
5/4" x 6" recycled composite lumber decking	B1@.225	SF	10.80	7.67	18.47
2" x 8" recycled composite lumber decking	B1@.225	SF	17.60	7.67	25.27

20' x 35'

Pine, pressure treated decking	B1@.170	SF	6.12	5.80	11.92
Redwood, select heart decking	B1@.170	SF	9.31	5.80	15.11
5/4" x 6" recycled composite lumber decking	B1@.225	SF	10.10	7.67	17.77
2" x 8" recycled composite lumber decking	B1@.225	SF	17.00	7.67	24.67

20' x 55'

Pine, pressure treated decking	B1@.170	SF	5.88	5.80	11.68
Redwood, select heart decking	B1@.170	SF	9.06	5.80	14.86
5/4" x 6" recycled composite lumber decking	B1@.225	SF	9.83	7.67	17.50
2" x 8" recycled composite lumber decking	B1@.225	SF	16.70	7.67	24.37

Deck flooring only These costs assume 5/4" x 6" southern yellow pine decking, 2" x 8" redwood decking, 5/4" x 6" recycled plastic lumber decking or 2" x 8" recycled composite lumber decking, and 5% waste. No deck support system included. Costs shown are based on a 200 SF job.

Pine, pressure treated deck flooring	B1@.030	SF	2.14	1.02	3.16
Redwood, select heart deck flooring	B1@.030	SF	5.33	1.02	6.35
5/4" x 6" recycled composite lumber decking	B1@.077	SF	6.10	2.63	8.73
2" x 8" recycled composite lumber decking	B1@.077	SF	13.00	2.63	15.63
Add for stain and sealer finish	B1@.006	SF	.20	.20	.40

Add for diagonal pattern decking

Pine decking, pressure treated	B1@.007	SF	.30	.24	.54
Redwood decking	B1@.007	SF	.75	.24	.99
5/4" x 6" recycled composite lumber decking	B1@.007	SF	.85	.24	1.09
2" x 8" recycled composite lumber decking	B1@.007	SF	1.82	.24	2.06

Deck Railing and Stairs

Craft@Hrs Unit Material Labor Total

Deck cover framing Can also be referred to as a pergola. Conventionally framed wood cover joists. Per SF of area covered. Figures in parentheses indicate board feet per square foot of ceiling including end joists, header joists, and 5% waste. Costs shown are based on a job with 200 SF of area covered and include normal waste. Add the cost of posts and finish roof.

2" x 4", Std & Btr grade					
16" centers (.59 BF per SF)	B1@.020	SF	.73	.68	1.41
24" centers (.42 BF per SF)	B1@.014	SF	.52	.48	1.00
2" x 6", Std & Btr grade					
16" centers (.88 BF per SF)	B1@.020	SF	1.11	.68	1.79
24" centers (.63 BF per SF)	B1@.015	SF	.79	.51	1.30

Add for posts to support conventionally framed wood cover joists. Posts are usually required at each corner. Includes one sack of concrete but no excavation.

4" x 4" pressure treated, 10' long	B1@.750	Ea	14.30	25.60	39.90
6" x 6" pressure treated, 10' long	B1@.750	Ea	37.30	25.60	62.90

Deck roof cover Cover over conventionally framed wood ceiling joists.

Flat deck built-up roofing. Using 1/2" CDX roof sheathing with 3 ply asphalt surface consisting of 2 plies of 15 lb felt with and 3 hot mop coats of asphalt and 90 lb cap sheet. Add the deck cover framing cost from the previous section.

Flat roof cover cost per SF	B1@.029	SF	3.83	.99	4.82
-----------------------------	---------	----	------	-----	------

Deck railing 42" high handrail. 2" x 2" paling 5" OC run vertically, lag bolted to the edge of the deck, one 2" x 4" horizontal top rail and one 2" x 6" placed on edge directly below the top rail.

Pine, pressure treated, per running foot	B1@.333	LF	6.97	11.40	18.37
Redwood, select heart, per running foot	B1@.333	LF	15.10	11.40	26.50
Recycled composite lumber, per running foot	B1@.333	LF	31.30	11.40	42.70

Deck stairs All stairs assume 12" tread (step) composed of two pieces of 2" x 6" framing lumber, a riser and supporting stringers. Add the cost of concrete supports below.

One or two steps high, box construction. Cost per linear foot of step. A 4' wide stairway with 2 steps has 8 linear feet of step.

Pine treads, open risers	B1@.270	LF	6.20	9.21	15.41
Pine treads, with pine risers	B1@.350	LF	10.50	11.90	22.40
Redwood treads, open risers	B1@.270	LF	6.85	9.21	16.06
Redwood treads, with redwood risers	B1@.350	LF	12.40	11.90	24.30
5/4" recycled composite lumber treads, open risers	B1@.270	LF	11.10	9.21	20.31
5/4" recycled composite lumber treads, with recycled composite lumber risers	B1@.350	LF	24.30	11.90	36.20
2" x 6" recycled composite lumber treads, open risers	B1@.270	LF	12.30	9.21	21.51
2" x 6" recycled composite lumber treads, with recycled composite lumber risers	B1@.350	LF	27.80	11.90	39.70

Three or more steps high, 36" wide. 3 stringers cut from 2" x 12" pressure treated lumber. Cost per riser.

Pine treads, open risers	B1@.530	Ea	22.70	18.10	40.80
Pine treads, with pine risers	B1@.620	Ea	35.60	21.10	56.70
Redwood treads, open risers	B1@.530	Ea	24.60	18.10	42.70
Redwood treads, with redwood risers	B1@.620	Ea	41.40	21.10	62.50
5/4" recycled composite lumber treads, open risers	B1@.270	LF	38.00	9.21	47.21
5/4" recycled composite lumber treads, with recycled composite lumber risers	B1@.350	LF	77.40	11.90	89.30

Demolition

	Craft@Hrs	Unit	Material	Labor	Total
2" x 6" recycled composite lumber treads, open risers	B1@.270	LF	41.50	9.21	50.71
2" x 6" recycled composite lumber treads, with recycled composite lumber risers	B1@.350	LF	88.00	11.90	99.90
Concrete footing to support deck stairway. Cost includes brackets and fasteners to attach stairway to the footing. Add the cost of excavation.					
18" x 18" x 12" footing	B1@.530	Ea	38.90	18.10	57.00

	Craft@Hrs	Unit	Material	Labor	Equipment	Total
--	-----------	------	----------	-------	-----------	-------

Demolition Itemized costs for demolition of building components when building is being remodeled, repaired or rehabilitated, not completely demolished. Costs include protecting adjacent areas and normal clean-up. Costs are to break out the items listed and pile debris on site only. No hauling, dump fees or salvage value included. Equipment cost includes one air compressor and a pneumatic breaker with jackhammer bits. . (Figures in parentheses show the volume before and after demolition and weight of the materials after demolition.) Use \$250.00 as a minimum charge.

Brick walls and walks, cost per SF removed, measured on one face, using pneumatic breaker

4" thick walls (60 SF per CY and 36 lbs. per SF)	BL@.061	SF	—	1.86	1.13	2.99
8" thick walls (30 SF per CY and 72 lbs. per SF)	BL@.110	SF	—	3.36	2.04	5.40
12" thick walls (20 SF per CY and 108 lbs. per SF)	BL@.133	SF	—	4.06	2.46	6.52
Brick sidewalks, cost per SF removed, 5 brick (3-3/4" x 2-1/2" x 8") per SF, salvage condition 2-1/2" thick bricks on sand base, no mortar bed, removed using hand tools (100 SF per CY and 28 lbs. per SF)	BL@.020	SF	—	.61	—	.61
Brick pavers up to 4-1/2" thick with mortar bed, removed using a pneumatic breaker (55 SF per CY and 50 lbs. per SF)	BL@.050	SF	—	1.53	.93	2.46
Ceiling tile, cost per in-place SF removed using hand tools						
Stapled or glued 12" x 12" (250 SF per CY and .25 lbs. per SF)	BL@.015	SF	—	.46	—	.46
Suspended panels 2' x 4' (250 SF per CY and .25 lbs. per SF)	BL@.010	SF	—	.31	—	.31
Concrete masonry walls, cost per in-place SF removed, using a pneumatic breaker						
4" thick walls (60 SF per CY and 19 lbs. per SF)	BL@.066	SF	—	2.02	1.22	3.24
6" thick walls (40 SF per CY and 28 lbs. per SF)	BL@.075	SF	—	2.29	1.39	3.68
8" thick walls (30 SF per CY and 34 lbs. per SF)	BL@.098	SF	—	2.99	1.82	4.81
12" thick walls (20 SF per CY and 46 lbs. per SF)	BL@.140	SF	—	4.28	2.59	6.87
Reinforced or grouted walls add	—	%	—	50.0	50.0	—
Concrete foundations (footings), steel reinforced, removed using a pneumatic breaker. Concrete at 3,900 pounds per in place cubic yard.						
Cost per CY (.75 CY per CY)	BL@3.96	CY	—	121.00	73.40	194.40
Cost per LF with width and depth as shown						
6" W x 12" D (35 LF per CY)	BL@.075	LF	—	2.29	1.39	3.68
8" W x 12" D (30 LF per CY)	BL@.098	LF	—	2.99	1.82	4.81
8" W x 16" D (20 LF per CY)	BL@.133	LF	—	4.06	2.46	6.52
8" W x 18" D (18 LF per CY)	BL@.147	LF	—	4.49	2.72	7.21
10" W x 12" D (21 LF per CY)	BL@.121	LF	—	3.70	2.24	5.94
10" W x 16" D (16 LF per CY)	BL@.165	LF	—	5.04	3.06	8.10
10" W x 18" D (14 LF per CY)	BL@.185	LF	—	5.65	3.43	9.08

Demolition

	Craft@Hrs	Unit	Material	Labor	Equipment	Total
12" W x 12" D (20 LF per CY)	BL@.147	LF	—	4.49	2.72	7.21
12" W x 16" D (13 LF per CY)	BL@.196	LF	—	5.99	3.63	9.62
12" W x 20" D (11 LF per CY)	BL@.245	LF	—	7.48	4.54	12.02
12" W x 24" D (9 LF per CY)	BL@.294	LF	—	8.98	5.45	14.43
Concrete sidewalks, to 4" thick, cost per SF removed. Concrete at 3,900 pounds per in place cubic yard.						
Non-reinforced, removed by hand						
(60 SF per CY)	BL@.050	SF	—	1.53	—	1.53
Reinforced, removed using pneumatic breaker						
(55 SF per CY)	BL@.033	SF	—	1.01	.61	1.62
Concrete slabs, non-reinforced, removed using pneumatic breaker. Concrete at 3,900 pounds per in-place cubic yard.						
Cost per CY (.80 CY per CY)	BL@3.17	CY	—	96.80	58.80	155.60
Cost per SF with thickness as shown						
3" slab thickness (90 SF per CY)	BL@.030	SF	—	.92	.56	1.48
4" slab thickness (60 SF per CY)	BL@.040	SF	—	1.22	.74	1.96
6" slab thickness (45 SF per CY)	BL@.056	SF	—	1.71	1.04	2.75
8" slab thickness (30 SF per CY)	BL@.092	SF	—	2.81	1.71	4.52
Concrete slabs, steel reinforced, removed using pneumatic breaker. Concrete at 3,900 pounds per in-place cubic yard.						
Cost per CY (1.33 CY per CY)	BL@3.96	CY	—	121.00	73.40	194.40
Cost per SF with thickness as shown						
3" slab thickness (80 SF per CY)	BL@.036	SF	—	1.10	.67	1.77
4" slab thickness (55 SF per CY)	BL@.050	SF	—	1.53	.93	2.46
6" slab thickness (40 SF per CY)	BL@.075	SF	—	2.29	1.39	3.68
8" slab thickness (30 SF per CY)	BL@.098	SF	—	2.99	1.82	4.81
Concrete walls, steel reinforced, removed using pneumatic breaker. Concrete at 3,900 pounds per in-place cubic yard.						
Cost per CY (1.33 CY per CY)	BL@4.76	CY	—	145.00	88.20	233.20
Cost per SF with thickness as shown (deduct openings over 25 SF)						
3" wall thickness (80 SF per CY)	BL@.045	SF	—	1.37	.83	2.20
4" wall thickness (55 SF per CY)	BL@.058	SF	—	1.77	1.07	2.84
5" wall thickness (45 SF per CY)	BL@.075	SF	—	2.29	1.39	3.68
6" wall thickness (40 SF per CY)	BL@.090	SF	—	2.75	1.67	4.42
8" wall thickness (30 SF per CY)	BL@.120	SF	—	3.67	2.22	5.89
10" wall thickness (25 SF per CY)	BL@.147	SF	—	4.49	2.72	7.21
12" wall thickness (20 SF per CY)	BL@.176	SF	—	5.38	3.26	8.64
Curbs and 18" gutter, concrete, removed using pneumatic breaker. Concrete at 3,900 pounds per in-place cubic yard.						
Cost per LF (8 LF per CY)	BL@.422	LF	—	12.90	7.82	20.72
Doors, typical cost to remove door, frame and hardware						
3' x 7' metal (2 doors per CY)	BL@1.00	Ea	—	30.60	—	30.60
3' x 7' wood (2 doors per CY)	BL@.497	Ea	—	15.20	—	15.20
Flooring, cost per in-place SY of floor area removed (1 square yard = 9 square feet)						
Ceramic tile						
(25 SY per CY and 34 lbs. per SY)	BL@.263	SY	—	8.03	—	8.03
Hardwood, nailed						
(25 SY per CY and 18 lbs. per SY)	BL@.290	SY	—	8.86	—	8.86
Hardwood, glued						
(25 SY per CY and 18 lbs. per SY)	BL@.503	SY	—	15.40	—	15.40
Laminated wood, floating, engineered, "Pergo"						
(30 SY per CY and 5 lbs. per SY)	BL@.013	SY	—	.40	—	.40

Demolition

	Craft@Hrs	Unit	Material	Labor	Equipment	Total
Linoleum, sheet (30 SY per CY and 3 lbs. per SY)	BL@.056	SY	—	1.71	—	1.71
Carpet (40 SY per CY and 5 lbs. per SY)	BL@.028	SY	—	.86	—	.86
Carpet pad (35 SY per CY and 1.7 lbs. per SY)	BL@.014	SY	—	.43	—	.43
Resilient tile (30 SY per CY and 3 lbs. per SY)	BL@.070	SY	—	2.14	—	2.14
Terrazzo (25 SY per CY and 34 lbs. per SY)	BL@.286	SY	—	8.74	—	8.74
Remove mastic, using power sander	BL@.125	SY	—	3.82	—	3.82
Insulation, fiberglass batts, cost per in-place SF removed R-11 to R-19 (500 SF per CY and .3 lb per SF)	BL@.003	SF	—	.09	—	.09
Pavement, asphaltic concrete (bituminous) to 6" thick, removed using pneumatic breaker Cost per SY (4 SY per CY and 660 lbs. per SY)	BL@.250	SY	—	7.64	4.63	12.27
Plaster walls or ceilings, interior, cost per in-place SF removed by hand (300 SF per CY and 8 lbs. per SF)	BL@.015	SF	—	.46	—	.46
Roofing, cost per in-place square (100 SF), removed using hand tools, 1- or 2-story, easy access, pitch to 6 in 12. Add \$20 per square when fall protection (rope & harness) is required. Add \$15 per square for pitch over 6 in 12 (support planks required).						
Built-up, 5 ply or cap sheet (2.5 Sq per CY and 250 lbs per Sq)	BL@1.79	Sq	—	54.70	—	54.70
Built-up roofing with rock dress, solid mopped (2.5 Sq per CY and 240 lbs per Sq)	BL@2.02	Sq	—	61.70	—	61.70
Shingles, composition, single layer (2.5 Sq per CY and 240 lbs per Sq)	BL@1.85	Sq	—	56.50	—	56.50
Shingles, composition, double layer (1.2 Sq per CY and 480 lbs per Sq)	BL@3.05	Sq	—	93.20	—	93.20
Shingles, wood, single layer (1.7 Sq per CY and 400 lbs per Sq)	BL@2.02	Sq	—	61.70	—	61.70
Shingles, wood, double layer (0.8 Sq per CY and 800 lbs per Sq)	BL@3.05	Sq	—	93.20	—	93.20
Concrete "S" tile roofing (0.8 Sq per CY and 900 lbs per Sq)	BL@3.81	Sq	—	116.00	—	116.00
Clay tile roofing, 2-piece, pans and caps (0.8 Sq per CY and 900 lbs per Sq)	BL@4.80	Sq	—	147.00	—	147.00
Slate roofing (0.9 Sq per CY and 1000 lbs per Sq)	BL@3.81	Sq	—	116.00	—	116.00
Sheathing, up to 1" thick, cost per in-place SF, removed using hand tools						
Gypsum (250 SF per CY and 2.3 lbs. per SF)	BL@.017	SF	—	.52	—	.52
Plywood (200 SF per CY and 2 lbs. per SF)	BL@.017	SF	—	.52	—	.52
Siding, up to 1" thick, cost per in-place SF, removed using hand tools						
Metal (200 SF per CY and 2 lbs. per SF)	BL@.027	SF	—	.82	—	.82
Plywood (200 SF per CY and 2 lbs. per SF)	BL@.017	SF	—	.52	—	.52
Wood, boards (250 SF per CY and 2 lbs. per SF)	BL@.030	SF	—	.92	—	.92
Stucco walls or soffits, cost per in-place SF, removed using hand tools						
Stripping stucco wall cover back to the sheathing (300 SF per CY and 8 lbs. per SF)	BL@.036	SF	—	1.10	—	1.10
Trees. See Excavation						
Wallboard up to 1" thick, cost per in-place SF, removed using hand tools						
Gypsum, walls or ceilings (250 SF per CY and 2.3 lbs. per SF)	BL@.018	SF	—	.55	—	.55
Plywood or insulation board (200 SF per CY and 2 lbs. per SF)	BL@.018	SF	—	.55	—	.55

Demolition

	Craft@Hrs	Unit	Material	Labor	Equipment	Total
Windows, typical cost to remove window, frame and hardware, cost per SF of window						
Metal (36 SF per CY)	BL@.058	SF	—	1.77	—	1.77
Wood (36 SF per CY)	BL@.063	SF	—	1.92	—	1.92
Wood stairs, cost per in-place SF or LF						
Risers (with tread) (25 SF per CY)	BL@.116	SF	—	3.54	—	3.54
Landings (50 SF per CY)	BL@.021	SF	—	.64	—	.64
Handrails (100 LF per CY)	BL@.044	LF	—	1.34	—	1.34
Posts (200 LF per CY)	BL@.075	LF	—	2.29	—	2.29

Craft@Hrs	Unit	Material	Labor	Total
-----------	------	----------	-------	-------

Wood Framing Demolition Typical costs for demolition of wood frame structural components using hand tools. Normal center to center spacing (12" thru 24" OC) is assumed. Costs include removal of type NM non-metallic (Romex) cable as necessary, protecting adjacent areas, and normal clean-up. Costs do not include temporary shoring to support structural elements above or adjacent to the work area. (Add for demolition of flooring, roofing, sheathing, etc.) Figures in parentheses give the approximate "loose" volume and weight of the materials after being demolished.

Ceiling joists, per in-place SF of ceiling area removed

2" x 4" (720 SF per CY and 1.18 lbs. per SF)	BL@.009	SF	—	.27	.27
2" x 6" (410 SF per CY and 1.76 lbs. per SF)	BL@.013	SF	—	.40	.40
2" x 8" (290 SF per CY and 2.34 lbs. per SF)	BL@.018	SF	—	.55	.55
2" x 10" (220 SF per CY and 2.94 lbs. per SF)	BL@.023	SF	—	.70	.70
2" x 12" (190 SF per CY and 3.52 lbs. per SF)	BL@.027	SF	—	.82	.82

Floor joists, per in-place SF of floor area removed

2" x 6" (290 SF per CY and 2.04 lbs. per SF)	BL@.016	SF	—	.49	.49
2" x 8" (190 SF per CY and 2.72 lbs. per SF)	BL@.021	SF	—	.64	.64
2" x 10" (160 SF per CY and 3.42 lbs. per SF)	BL@.026	SF	—	.79	.79
2" x 12" (120 SF per CY and 4.10 lbs. per SF)	BL@.031	SF	—	.95	.95

Rafters, per in-place SF of actual roof area removed

2" x 4" (610 SF per CY and 1.42 lbs. per SF)	BL@.011	SF	—	.34	.34
2" x 6" (360 SF per CY and 2.04 lbs. per SF)	BL@.016	SF	—	.49	.49
2" x 8" (270 SF per CY and 2.68 lbs. per SF)	BL@.020	SF	—	.61	.61
2" x 10" (210 SF per CY and 3.36 lbs. per SF)	BL@.026	SF	—	.79	.79
2" x 12" (180 SF per CY and 3.94 lbs. per SF)	BL@.030	SF	—	.92	.92

Stud walls, interior or exterior, includes allowance for plates and blocking, per in-place SF of wall area removed, measured on one face

2" x 3" (430 SF per CY and 1.92 lbs. per SF)	BL@.013	SF	—	.40	.40
2" x 4" (310 SF per CY and 2.58 lbs. per SF)	BL@.017	SF	—	.52	.52
2" x 6" (190 SF per CY and 3.74 lbs. per SF)	BL@.025	SF	—	.76	.76

Demolition

Craft@Hrs Unit Material Labor Total

Wood Framed Assemblies Demolition Typical costs for demolition of wood framed structural assemblies using hand tools when a building is being remodeled, repaired or rehabilitated but not completely demolished. Costs include removal of type NM non-metallic (Romex) cable as necessary, protecting adjacent areas and normal clean-up. Costs do not include temporary shoring to support structural elements above or adjacent to the work area, loading, hauling, dump fees or salvage value. Costs shown are per in-place square foot (SF) of area being demolished. Normal center to center spacing (12" thru 24" OC) is assumed. Figures in parentheses give the approximate "loose" volume and weight of the materials (volume after being demolished and weight.)

Ceiling assemblies. Remove ceiling joists, fiberglass insulation and gypsum board up to 5/8" thick					
2" x 4" (135 SF per CY and 3.78 lbs. per SF)	BL@.030	SF	—	.92	.92
2" x 6" (118 SF per CY and 4.36 lbs. per SF)	BL@.034	SF	—	1.04	1.04
2" x 8" (106 SF per CY and 4.94 lbs. per SF)	BL@.039	SF	—	1.19	1.19
2" x 10" (95 SF per CY and 5.54 lbs. per SF)	BL@.043	SF	—	1.31	1.31
2" x 12" (89 SF per CY and 6.12 lbs. per SF)	BL@.048	SF	—	1.47	1.47
Floor assemblies. Remove floor joists and plywood subfloor up to 3/4" thick					
2" x 8" (97 SF per CY and 4.72 lbs. per SF)	BL@.035	SF	—	1.07	1.07
2" x 10" (88 SF per CY and 5.42 lbs. per SF)	BL@.040	SF	—	1.22	1.22
2" x 12" (75 SF per CY and 6.10 lbs. per SF)	BL@.043	SF	—	1.31	1.31
For gypsum board ceiling removed below floor joists, add to any of above					
(250 SF per CY and 2.3 lbs. per SF)	BL@.018	SF	—	.55	.55
Wall assemblies, interior. Remove studs, 2 top plates, 1 bottom plate and gypsum drywall up to 5/8" thick on both sides					
2" x 3" (97 SF per CY and 6.52 lbs. per SF)	BL@.048	SF	—	1.47	1.47
2" x 4" (89 SF per CY and 7.18 lbs. per SF)	BL@.052	SF	—	1.59	1.59
2" x 6" (75 SF per CY and 8.34 lbs. per SF)	BL@.059	SF	—	1.80	1.80
Wall assemblies, exterior. Remove studs, 2 top plates, 1 bottom plate, insulation, gypsum drywall up to 5/8" thick on one side, plywood siding up to 3/4" thick on other side					
2" x 4" (70 SF per CY and 7.18 lbs. per SF)	BL@.067	SF	—	2.05	2.05
2" x 6" (75 SF per CY and 8.34 lbs. per SF)	BL@.074	SF	—	2.26	2.26
For stucco in lieu of plywood, add to any of above					
(SF per CY is the same and add 6 lbs. per SF)	BL@.006	SF	—	.18	.18

Demolition, Subcontract Costs for demolishing and removing an entire building using a dozer and front-end loader. Costs shown include loading and hauling up to 5 miles, but no dump fees. Dump charges vary widely; see Disposal Fees in the Site Work Section of the Industrial and Commercial division of this book. Costs shown are for above ground structures only, per in-place SF of total floor area with ceilings up to 10' high. No salvage value assumed. Add the cost of foundation demolition. Figures in parentheses give the approximate "loose" volume of the materials (volume after being demolished)

Light wood-frame structures, up to three stories in height. Based on 2,500 SF job. No basements included. Estimate each story separately. Cost per in-place SF floor area					
First story (8 SF per CY)	—	SF	—	—	2.49
Second story (8 SF per CY)	—	SF	—	—	3.27
Third story (8 SF per CY)	—	SF	—	—	4.21
Masonry building, cost per in-place SF floor area					
based on 5,000 SF job (50 SF per CY)	—	SF	—	—	4.10
Concrete building, cost per in-place SF floor area					
based on 5,000 SF job (30 SF per CY)	—	SF	—	—	5.63
Reinforced concrete building, cost per in-place SF floor area					
based on 5,000 SF job (20 SF per CY)	—	SF	—	—	6.05

Doors, Chimes

	Craft@Hrs	Unit	Material	Labor	Total
Door Chimes Electric, typical installation, add transformer and wire below.					
Surface mounted, 2 notes, wired					
Simple white plastic chime, 4" x 7"	BE@3.50	Ea	26.60	144.00	170.60
Modern oak grained finish, plastic, 8" x 5"	BE@3.50	Ea	48.90	144.00	192.90
White, with repeating tones	BE@3.50	Ea	72.50	144.00	216.50
Maple finish, plastic, 8" x 5"	BE@3.50	Ea	49.00	144.00	193.00
Designer, wood-look plastic strips across a cloth grille, wired					
9" x 7"	BE@3.50	Ea	48.50	144.00	192.50
Modern real oak wood, with brass plated chimes, wired					
9" x 7"	BE@3.50	Ea	88.40	144.00	232.40
Surface mounted, 4 to 8 notes, solid wood door chime, wired					
Three 12" long tubes	BE@3.64	Ea	215.00	149.00	364.00
Four 55" long tubes	BE@3.64	Ea	276.00	149.00	425.00
Non-electric, push button type, door mounted					
Modern design, 2-1/2" x 2-1/2"	BE@.497	Ea	27.10	20.40	47.50
With peep sight, 7" x 3-1/2"	BE@.497	Ea	16.30	20.40	36.70
Wireless door chimes, with push button transmitter, 3-year battery, 150' range, 2" speaker, 128 codes					
Oak housing with satin chime tubes	BE@.358	Ea	47.70	14.70	62.40
Wi-Fi 1080p video door bell. Assumes an existing Wi-Fi connection.					
Wired, add transformer and wire cost	BE@.358	Ea	57.00	14.70	71.70
Wired or wireless	BE@.358	Ea	105.00	14.70	219.70
Wired or wireless, two-way talk	BE@.358	Ea	210.00	14.70	224.70
Add for interior ring chime	BE@.358	Ea	35.00	14.70	49.70
Any of above					
Add for bell transformer	—	Ea	12.30	—	12.30
Add for bell wire and 65' run, connected	BE@1.75	Ea	5.02	71.80	76.72
Door Closers					
Residential and light commercial door closers, doors to 140 lbs and 38" wide. 150 degree maximum swing, non-hold open, adjustable closing speed, ANSI A156.4					
Pneumatic, back door closer	BC@.750	Ea	11.40	28.20	39.60
Medium duty door closers, interior doors to 36" wide.					
Bronze, residential	BC@1.04	Ea	58.60	39.20	97.80
Aluminum, commercial	BC@1.04	Ea	95.00	39.20	134.20
Heavy duty door closers, doors to 170 lbs. and 36" wide. Schlage					
Aluminum	BC@1.04	Ea	67.60	39.20	106.80
Aluminum with cover	BC@1.04	Ea	74.90	39.20	114.10
Screen door closers, brass finish					
Pneumatic closer, light duty	BC@.546	Ea	18.20	20.60	38.80
Spring loaded, automatic, for doors up to 30 lbs, brass finish					
Brass finish	BC@.250	Ea	9.88	9.42	19.30
Sliding door closers, pneumatic, aluminum finish					
Screen	BC@.250	Ea	175.00	9.42	184.42
Glass	BC@.250	Ea	136.00	9.42	145.42

Doors, Exterior

Craft@Hrs Unit Material Labor Total

Exterior Slab Doors Exterior doors are usually 1-3/4" thick and solid core – a thin veneer laid over a frame but with foam or composition board filling the door cavity. Flush doors are smooth and flat with no decorative treatment. Slab doors are the door alone, as distinguished from prehung doors which are sold with jamb, hinges, trim and threshold. Installation times for slab doors will be up to 50% faster when an experienced carpenter has the use of a router, door jig and pneumatic nailer.

Flush lauan exterior doors. Solid core. 1-3/4" thick. Unfinished wood grain. Lauan is a tropical hardwood like mahogany. Labor includes setting three hinges on the door and jamb and hanging the door in an existing cased opening.

30" x 80"	BC@1.45	Ea	72.20	54.60	126.80
32" x 80"	BC@1.45	Ea	82.50	54.60	137.10
36" x 80"	BC@1.45	Ea	80.50	54.60	135.10

Flush hardboard exterior doors. Particle board core, 1-3/4" thick, primed. Labor includes setting three hinges on the door and jamb and hanging the door in an existing cased opening.

30" x 80"	BC@1.45	Ea	92.80	54.60	147.40
32" x 80"	BC@1.45	Ea	101.00	54.60	155.60
34" x 80"	BC@1.45	Ea	101.00	54.60	155.60
36" x 80"	BC@1.45	Ea	107.30	54.60	161.90

Steel exterior panel doors. Insulating core. Primed. Six panels. 1-3/4" thick. Labor includes setting three hinges on the door and jamb and hanging the door in an existing cased opening.

30" x 80"	BC@1.45	Ea	123.00	54.60	177.60
32" x 80"	BC@1.45	Ea	123.00	54.60	177.60
36" x 80"	BC@1.45	Ea	123.00	54.60	177.60

1-lite exterior doors. Insulating core. Primed white wood. 1-3/4" thick. Insulated obscure tempered glass. Labor includes setting three hinges on the door and jamb and hanging the door in an existing cased opening.

28" x 80"	BC@1.45	Ea	360.00	54.60	414.60
30" x 80"	BC@1.45	Ea	360.00	54.60	414.60
32" x 80"	BC@1.45	Ea	360.00	54.60	414.60
36" x 80"	BC@1.45	Ea	360.00	54.60	414.60
42" x 80"	BC@1.45	Ea	515.00	54.60	569.60
Add for 84" or 96" height	—	Ea	46.40	—	46.40
Add for prehung door with matching jambs	—	Ea	257.00	—	257.00

Doors, Entry Slab

Craft@Hrs Unit Material Labor Total

Entry Slab Doors Any exterior door can be used at the front entry of a home. But entry doors usually include decorative elements, such as glass panels set in a border of brass caming. Slab doors are the door alone, as distinguished from prehung doors which are sold with jamb, hinges, trim and threshold attached. Installation times for entry doors will be up to 50% faster when an experienced carpenter has the use of a router, door jig and pneumatic nailer.

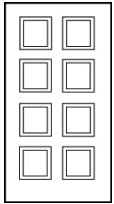

Hardwood panel entry doors. 1-3/4" thick. Unfinished solid wood. Ready to paint or stain. Labor includes setting three hinges on the door and jamb and hanging the door in an existing cased opening.

30" x 80"	BC@1.45	Ea	670.00	54.60	724.60
32" x 80"	BC@1.45	Ea	670.00	54.60	724.60
36" x 80"	BC@1.45	Ea	670.00	54.60	724.60
42" x 80"	BC@1.45	Ea	876.00	54.60	930.60
Add for 96" height	—	Ea	51.60	—	51.60
Add for prehung door with matching jambs	—	Ea	257.00	—	257.00



Hardwood 1-lite entry doors. 1-3/4" thick. Dual glazed. Unfinished. Suitable for stain or paint. Labor includes setting three hinges on the door and jamb and hanging the door in an existing cased opening.

28" x 80"	BC@1.70	Ea	308.00	64.00	372.00
30" x 80"	BC@1.70	Ea	329.00	64.00	393.00
32" x 80"	BC@1.70	Ea	339.00	64.00	403.00
36" x 80"	BC@1.70	Ea	360.00	64.00	424.00
42" x 80"	BC@1.70	Ea	515.00	64.00	579.00

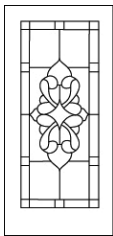

Beveled glass entry doors. 1-3/4" thick. Triple-glazed. Unfinished hardwood. Labor includes setting three hinges on the door and jamb and hanging the door in an existing cased opening.

28" x 80"	BC@1.70	Ea	721.00	64.00	785.00
30" x 80"	BC@1.70	Ea	721.00	64.00	785.00
32" x 80"	BC@1.70	Ea	721.00	64.00	785.00
36" x 80"	BC@1.70	Ea	721.00	64.00	785.00
Add for 12" W beveled glass sidelight	BC@1.00	Ea	515.00	37.70	552.70
Add for 14" H beveled glass transom	BC@1.00	Ea	979.00	37.70	1,016.70
Add for 96" height	—	Ea	103.00	—	103.00
Add for prehung door with matching jambs	—	Ea	257.00	—	257.00

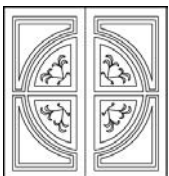

Carved hardwood double doors. Hand carved hardwood. Unfinished. 1-3/4" thick. Labor includes setting six hinges on the door and jamb and hanging the doors in an existing cased opening.

72" x 80"	BC@3.40	Set	1,130.00	128.00	1,258.00
72" x 96"	BC@3.40	Set	1,260.00	128.00	1,388.00
Add for prehung set with matching jambs	—	Set	385.00	—	385.00

Doors, Trim, Exterior

Craft@Hrs Unit Material Labor Total

Trim for Exterior Slab Doors Trim for an exterior slab door includes two side jambs, head jamb, threshold, stop molding, interior casing and exterior molding. Installation time for exterior door trim will be up to 33% faster when an experienced carpenter has the use of a pneumatic nailer

Exterior door jamb. A door jamb set consists of two legs and one 3' head.

4-5/8" x 1-1/4" x 7', composite	BC@.204	Ea	39.60	7.68	47.28
4-5/8" x 1-1/4" x 7' pine jamb set	BC@.500	Ea	56.00	18.80	74.80
5-1/4" wide, per set	BC@.500	Ea	70.70	18.80	89.50
6-9/16" x 1-1/4" x 7' PVC jamb set	BC@.500	Set	133.00	18.80	151.80
6-9/16" x 1-1/4" x 8', PVC jamb set	BC@.500	Set	195.00	18.80	213.80

Oak high boy threshold. Fits standard door sizes.

5/8" x 3-1/2" x 36"	BC@.518	Ea	17.90	19.50	37.40
---------------------	---------	----	-------	-------	-------

Stop molding. Nails to face of the door jamb to prevent door from swinging through the opening. Solid pine.

3/8" x 1-1/4" x 96", pine	BC@.120	Ea	5.79	4.52	10.31
3/8" x 1-1/4" x 84", knotty adler	BC@.120	Ea	11.90	4.52	16.42
9/16" x 1-5/8" x 96", poly	BC@.120	LF	7.30	4.52	11.82

Door casing. Casing is the trim around each side and head of the interior side of an exterior door. Casing covers the joint between jamb and the wall.

19/32" x 2-1/4" x 7', MDF	BC@.105	Ea	4.54	3.95	8.49
11/16" x 2-1/4" x 7', pine	BC@.105	Ea	7.73	3.95	11.68
11/16" x 2-1/2" x 7', pine, 5 pieces	BC@.525	Set	29.60	19.80	49.40

Brick mold. Brick mold and stucco mold are the casing around each side and head on the exterior side of an exterior door.

1-1/4" x 2" x 7', pine, 3-piece set	BC@.255	Set	22.40	9.60	32.00
1-1/4" x 2" x 10', vinyl	BC@.150	Ea	20.70	5.65	26.35
1-1/4" x 2", PVC	BC@.015	LF	1.89	.56	2.45
1-5/8" x 11/16" x 8', vinyl	BC@.120	Ea	10.30	4.52	14.82
1-1/4" x 2", treated pine	BC@.015	LF	3.34	.56	3.90

Stucco molding. Finger joint

1" x 1-3/8" pine	BC@.015	LF	1.53	.56	2.09
------------------	---------	----	------	-----	------

T-astragal molding. Covers the vertical joint where a pair of doors meet.

1-1/4" x 2" x 7', pine	BC@.529	Ea	18.10	19.90	38.00
------------------------	---------	----	-------	-------	-------

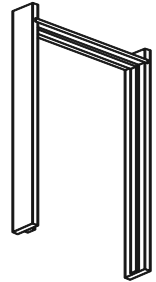

Doors, Fire-Rated

Craft@Hrs Unit Material Labor Total

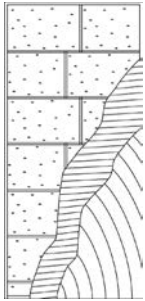

Fire-Rated Doors Fire-rated doors are designed to meet building code requirements for specialized occupancies, such as hotel rooms and dormitories. Most building codes require a 20-minute fire door between a house and an attached garage.

6-panel prehung steel fire-rated exterior doors. 24-gauge galvanized steel. Foam core. Caming matches hinge and sill finishes. Jamb guard security plate. No brick mold. Fixed sill. 4-9/16" primed jamb. Triple sweep compression weatherstripping. Factory primed. Thermal-break threshold. 20-minute fire rating. 10-year limited warranty.

30" x 80"	BC@1.00	Ea	547.00	37.70	584.70
32" x 80"	BC@1.00	Ea	554.00	37.70	591.70
36" x 80"	BC@1.00	Ea	561.00	37.70	598.70

Prehung hardboard fire-rated interior doors. 20-minute fire rating. Labor includes hanging the door in an existing framed opening.

30" x 80"	BC@1.00	Ea	250.00	37.70	287.70
32" x 80"	BC@1.00	Ea	250.00	37.70	287.70
36" x 80"	BC@1.00	Ea	250.00	37.70	287.70

Flush fire-rated steel slab doors. 1-3/4" thick. 20-minute fire rating. Primed. Labor includes setting three hinges on the door and jamb and hanging the door in an existing cased opening.

30" x 80"	BC@1.45	Ea	201.00	54.60	255.60
32" x 80"	BC@1.45	Ea	201.00	54.60	255.60
36" x 80"	BC@1.45	Ea	201.00	54.60	255.60

Flush 90-minute fire-rated steel slab doors. 1-3/4" thick. Primed. With hardware. Labor includes assembling the door, frame and lockset and hanging the door in an existing cased opening.

36" x 80" door and knocked down frame	BC@1.85	Ea	534.00	69.70	603.70
36" x 84" door and knocked down frame	BC@1.85	Ea	549.00	69.70	618.70
36" x 80" door and assembled frame	BC@1.45	Ea	581.00	54.60	635.60
36" x 84" door and assembled frame	BC@1.45	Ea	592.00	54.60	646.60
Add for panic bar hardware	—	Ea	275.00	—	275.00
Add for deadbolt	—	Ea	52.90	—	52.90

Steel cellar doors. See Basement Doors.

Doors, Prehung Exterior

Craft@Hrs Unit Material Labor Total

Prehung Wood Exterior Doors Prehung doors are sold as a package with the door, jamb, hinges, weatherstripping, threshold and trim already assembled.

Flush hardboard prehung exterior doors. 1-3/4" door. Solid core. Weatherstripped. Includes sill and threshold with vinyl insert. Finger joint 4-9/16" jamb and finger joint brick mold. 2-1/8" bore for lockset with 2-3/8" backset. Flush doors are smooth and flat with no decorative treatment. Labor includes hanging the door in an existing framed opening.

32" x 80"	BC@1.00	Ea	203.00	37.70	240.70
36" x 80"	BC@1.00	Ea	203.00	37.70	240.70

Rustic knotty adler prehung exterior doors. Two panel. Solid core. Weatherstripped. Unfinished. Includes sill and threshold. Labor includes hanging the door in an existing framed opening.

30" x 80"	BC@1.00	Ea	692.00	37.70	729.70
32" x 80"	BC@1.00	Ea	700.00	37.70	737.70
36" x 80"	BC@1.00	Ea	701.00	37.70	738.70
42" x 80"	BC@1.00	Ea	850.00	37.70	887.70
30" x 96"	BC@1.20	Ea	726.00	45.20	771.20
32" x 96"	BC@1.20	Ea	761.00	45.20	806.20
36" x 96"	BC@1.20	Ea	989.00	45.20	1,034.20
42" x 96"	BC@1.20	Ea	1,100.00	45.20	1,145.20
30" x 80" with two 14" wide sidelights	BC@2.80	Ea	1,850.00	105.00	1,955.00

9-lite engineered wood prehung exterior doors. Solid core. Weatherstripped. Includes sill and threshold. Unfinished. Finger joint 4-9/16" jamb and finger joint brick mold. 2-1/8" bore for lockset with 2-3/8" backset. Labor includes hanging the door in an existing framed opening.

32" x 80"	BC@1.00	Ea	884.00	37.70	921.70
36" x 80"	BC@1.00	Ea	954.00	37.70	991.70

Sidelites for wood prehung exterior doors, 1-3/4" thick, tempered clear insulated glass, assembled, unfinished hardwood. Per sidelight.

12" x 80", single lite	BC@1.36	Ea	283.00	51.20	334.20
12" x 80", triple lite	BC@1.36	Ea	360.00	51.20	411.20
14" x 96", rustic, low-E glass	BC@1.36	Ea	752.00	51.20	803.20

Prehung Steel Exterior Doors Prehung doors are sold as a package with the door, jamb, hinges, weatherstripping, threshold and trim already assembled. Add for the lockset. Flush doors have a smooth, flat face with no decorative treatment.

Utility flush prehung steel exterior doors. No brick mold. Primed 26-gauge galvanized steel. Foam core.

30" x 80"	BC@1.00	Ea	181.00	37.70	218.70
32" x 80"	BC@1.00	Ea	181.00	37.70	218.70
36" x 80"	BC@1.00	Ea	181.00	37.70	218.70

Premium flush prehung steel exterior doors. No brick mold. 24-gauge galvanized steel. Foam core.

Compression weatherstrip. Triple fin sweep. Thermal threshold.

24" x 80"	BC@1.00	Ea	420.00	37.70	457.70
30" x 80"	BC@1.00	Ea	452.00	37.70	489.70
32" x 80"	BC@1.00	Ea	462.00	37.70	499.70
36" x 80"	BC@1.00	Ea	475.00	37.70	512.70

6-panel prehung steel exterior doors. With brick mold. Non-thermal threshold. Bored for lockset with 2-3/4" backset. Includes compression weatherstrip and thermal-break threshold. Panel doors have decorative raised panels in the colonial style. Six or nine panels are most common.

32" x 80"	BC@1.00	Ea	202.00	37.70	239.70
36" x 80"	BC@1.00	Ea	202.00	37.70	239.70

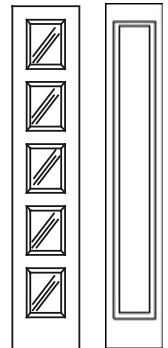

Doors, Prehung Exterior

Craft@Hrs Unit Material Labor Total

6-panel premium prehung exterior steel doors. 4-9/16" jamb. Adjustable thermal-break sill. 24-gauge galvanized steel. Bored for 2-3/8" lockset. 12" lock block. Polyurethane core. Triple sweep and compression weatherstripping. Factory primed.

30" x 80"	BC@1.00	Ea	428.00	37.70	465.70
32" x 80"	BC@1.00	Ea	428.00	37.70	465.70
36" x 80"	BC@1.00	Ea	520.00	37.70	557.70
42" x 80"	BC@1.00	Ea	550.00	37.70	587.70

6-panel prehung steel entry door with two 16" wide sidelites. Primed. Each sidelites has 3 divided lites.

72" x 80"	BC@2.00	Ea	1,250.00	75.30	1,325.30
-----------	---------	----	----------	-------	----------

Fan lite premium prehung steel exterior doors. No brick mold. 24-gauge galvanized steel. Foam core. Fixed sill. Compression weatherstripping. Factory primed. Thermal-break threshold.

32" x 80"	BC@1.00	Ea	202.00	37.70	239.70
36" x 80"	BC@1.00	Ea	245.00	37.70	282.70

Half lite prehung steel exterior doors. Tempered low-E glass. Adjustable sill. 24-gauge galvanized steel. Poly core. 4-9/16" jamb.

30" x 80"	BC@1.00	Ea	701.00	37.70	738.70
32" x 80"	BC@1.00	Ea	583.00	37.70	620.70
36" x 80"	BC@1.00	Ea	696.00	37.70	733.70

Full lite prehung steel exterior doors. 22" x 64" light. 4-9/16" jamb. Adjustable sill. With brick mold. 24-gauge galvanized steel. Tempered insulated glass.

32" x 80"	BC@1.00	Ea	518.00	37.70	555.70
36" x 80"	BC@1.00	Ea	539.00	37.70	576.70

6-lite, 2-panel prehung steel doors. 4-9/16" jamb. Adjustable sill. 24-gauge galvanized steel. Poly core. Primed. With brick mold.

30" x 80"	BC@1.00	Ea	424.00	37.70	461.70
32" x 80"	BC@1.00	Ea	424.00	37.70	461.70

9-lite prehung steel exterior doors. Insulating glass with external 9-lite grille. Adjustable sill. 24-gauge galvanized steel. No brick mold.

32" x 80"	BC@1.00	Ea	224.00	37.70	261.70
36" x 80"	BC@1.00	Ea	245.00	37.70	282.70

15-lite prehung steel exterior doors. Triple Low-E glazed with internal blinds and muttins, 4-9/16" jamb. 22" x 62" light. Adjustable sill. With brick mold.

32" x 80"	BC@1.00	Ea	1,070.00	37.70	1,107.70
36" x 80"	BC@1.00	Ea	1,070.00	37.70	1,107.70

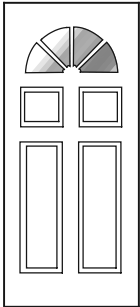

Doors, Prehung Entry

Craft@Hrs Unit Material Labor Total

Decorative Prehung Steel Entry Doors Entry doors are decorative exterior doors, often with glass panels set in a border of brass caming. Prehung doors are sold as a package with the door, jamb, hinges, threshold and trim already assembled.

Center arch lite prehung steel entry doors. 24-gauge galvanized steel. High-performance light frames. Decorative impact-resistant glass. Insulated core. 4-9/16" jamb with adjustable sill. Includes brick mold.					
36" x 80"	BC@1.00	Ea	481.00	37.70	518.70
Camber top glazed 4-panel prehung steel entry doors. 4-9/16" jamb. Primed. With brick mold.					
32" x 80"	BC@1.00	Ea	495.00	37.70	532.70
36" x 80"	BC@1.00	Ea	518.00	37.70	555.70

Internal mini-blinds prehung steel entry doors. Internal white blinds are enclosed by clear tempered glass. 4-9/16" jamb. 24-gauge steel. Poly core. With brick mold.					
36" x 80"	BC@1.00	Ea	750.00	37.70	787.70

Oval lite prehung steel entry door. 40" x 18" decorative oval laminated glass with brass caming. 24-gauge galvanized steel. Poly core. 4-9/16" jamb. Compression weatherstripping. Primed.					
36" x 80"	BC@1.00	Ea	643.00	37.70	680.70

Fan lite prehung steel entry doors. Polyurethane core. 6-9/16" frame. Laminated insulating glass insert has 5-lite grille on the exterior. 24-gauge galvanized steel. Weatherstripped.					
30" x 80"	BC@1.00	Ea	686.00	37.70	723.70
32" x 80"	BC@1.00	Ea	747.00	37.70	784.70
36" x 80"	BC@1.00	Ea	686.00	37.70	723.70

Vented half lite prehung steel entry doors. Poly core. 4-9/16" jamb. With screen. Tempered insulated glass.					
32" x 80"	BC@1.00	Ea	747.00	37.70	784.70
36" x 80"	BC@1.00	Ea	747.00	37.70	784.70

Fiberglass Prehung Entry Doors Fiberglass doors require very little maintenance and are available in simulated wood finish. Prehung doors include the door, jamb, hinges, threshold and trim already assembled.

6-panel fiberglass prehung exterior doors. Polyurethane core. PVC stiles and rails. Double bore. 4-9/16" prefinished jambs. Adjustable thermal-break brass threshold. Weatherstripped. With brick mold.					
32" x 80"	BC@1.00	Ea	241.00	37.70	278.70
36" x 80"	BC@1.00	Ea	241.00	37.70	278.70

Fan lite prehung light oak fiberglass entry doors. With brick mold. Factory prefinished. Triple pane insulated glass with brass caming. Adjustable brass thermal-break threshold and fully weatherstripped. 4-9/16" jamb.					
36" x 80"	BC@1.00	Ea	636.00	37.70	673.70

3/4 oval lite prehung fiberglass entry doors. With brick mold. Ready to finish.					
36" x 80", 4-9/16" jamb	BC@1.00	Ea	729.00	37.70	766.70
36" x 80", 6-9/16" jamb	BC@1.00	Ea	865.00	37.70	902.70

3/4 oval lite prehung light oak fiberglass doors. With brick mold. Prefinished. Polyurethane core. Triple pane insulated glass. Glue chip and clear 30" x 18" beveled glass surrounded by brass caming. Double bore. Extended wood lock block. 4-9/16" primed jamb. Thermal-break brass threshold with adjustable oak cap.					
36" x 80", 4-9/16" jamb	BC@1.00	Ea	1,180.00	37.70	1,217.70
36" x 80", 6-9/16" jamb	BC@1.00	Ea	1,270.00	37.70	1,307.70

Full height oval lite prehung medium oak fiberglass entry doors.					
36" x 80", 4-9/16" jamb	BC@1.00	Ea	1,060.00	37.70	1,097.70
36" x 80", 6-9/16" jamb	BC@1.00	Ea	1,700.00	37.70	1,737.70

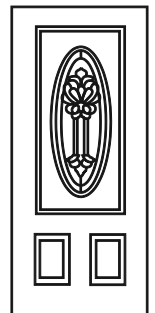
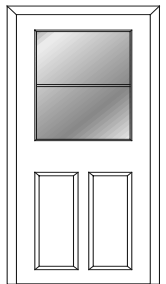
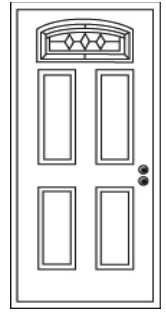

Doors, Screen

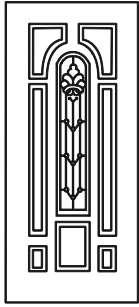

Center arch lite medium oak prehung fiberglass doors. Factory prefinished. Triple pane insulated glass with brass caming. Adjustable brass thermal-break threshold and fully weatherstripped. 4-9/16" jamb except as noted. PVC stiles and rails.

36" x 80", with brick mold	BC@1.00	Ea	1,140.00	37.70	1,177.70
----------------------------	---------	----	----------	-------	----------

36" x 80", with brick mold, 6-9/16" jamb	BC@1.00	Ea	1,690.00	37.70	1,727.70
---	---------	----	----------	-------	----------

Fan lite prehung fiberglass entry doors. With brick mold. Ready to finish. Insulated glass. Adjustable thermal-break brass threshold. 4-9/16" jamb except as noted.

32" x 80"	BC@1.00	Ea	571.00	37.70	608.70
-----------	---------	----	--------	-------	--------

36" x 80"	BC@1.00	Ea	582.00	37.70	619.70
-----------	---------	----	--------	-------	--------

36" x 80", 6-9/16" jamb	BC@1.00	Ea	694.00	37.70	731.70
-------------------------	---------	----	--------	-------	--------

9-lite fiberglass prehung exterior doors. Inward swing. With brick mold. Smooth face.

32" x 80"	BC@1.00	Ea	298.00	37.70	335.70
-----------	---------	----	--------	-------	--------

36" x 80"	BC@1.00	Ea	298.00	37.70	335.70
-----------	---------	----	--------	-------	--------

15-lite smooth prehung fiberglass entry doors. No brick mold. Factory prefinished. Left or right hinge. Triple pane, insulated glass with brass caming. Adjustable brass thermal-break threshold and fully weatherstripped. 4-9/16" jamb.

32" x 80"	BC@1.00	Ea	731.00	37.70	768.70
-----------	---------	----	--------	-------	--------

36" x 80"	BC@1.00	Ea	708.00	37.70	745.70
-----------	---------	----	--------	-------	--------

Full lite prehung smooth fiberglass doors. With brick mold. Inward swing.

36" x 80", 4-9/16" jamb	BC@1.00	Ea	1,100.00	37.70	1,137.70
-------------------------	---------	----	----------	-------	----------

36" x 80", 6-9/16" jamb	BC@1.00	Ea	1,100.00	37.70	1,137.70
-------------------------	---------	----	----------	-------	----------

Smooth prehung fiberglass ventlite exterior doors. Ready to finish. No brick mold.

32" x 80"	BC@1.00	Ea	322.00	37.70	359.70
-----------	---------	----	--------	-------	--------

36" x 80"	BC@1.00	Ea	356.00	37.70	393.70
-----------	---------	----	--------	-------	--------

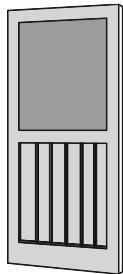

Screen Doors, Wood 3-3/4"-wide stile and rail with 7-1/4" bottom rail. Removable screen. Mortise and tenon construction. Wide center push bar. Ready to finish.

32" x 80"	BC@2.17	Ea	53.10	81.70	134.80
-----------	---------	----	-------	-------	--------

36" x 80"	BC@2.17	Ea	53.10	81.70	134.80
-----------	---------	----	-------	-------	--------

T-style wood screen doors. 3-3/4"-wide stile and rail with 7-1/4" bottom rail. 1-1/8" thick pine. Removable screen. Mortise and dowel construction. All joints sealed with water-resistant adhesive. Wide center push bar.

30" x 80"	BC@2.17	Ea	196.00	81.70	277.70
-----------	---------	----	--------	-------	--------

32" x 80"	BC@2.17	Ea	77.00	81.70	158.70
-----------	---------	----	-------	-------	--------

36" x 80"	BC@2.17	Ea	81.10	81.70	162.80
-----------	---------	----	-------	-------	--------

Screen doors, metal. Includes hardware and fiberglass screening. 1-piece steel frame. Heavy-duty pneumatic closer. 5" kickplate.

32" x 80"	BC@1.35	Ea	108.00	50.80	158.80
-----------	---------	----	--------	-------	--------

36" x 80"	BC@1.35	Ea	108.00	50.80	158.80
-----------	---------	----	--------	-------	--------

Screen doors, vinyl. Right or left side installation. 32" to 36" wide. Hardware included.

80" high, T-bar grid	BC@1.35	Ea	165.00	50.80	215.80
----------------------	---------	----	--------	-------	--------

80" high, full panel grid	BC@1.35	Ea	165.00	50.80	215.80
---------------------------	---------	----	--------	-------	--------

80" high, decorative	BC@1.35	Ea	165.00	50.80	215.80
----------------------	---------	----	--------	-------	--------

Five-bar solid vinyl screen doors. Accepts standard screen door hardware.

32" x 80"	BC@1.35	Ea	200.00	50.80	250.80
-----------	---------	----	--------	-------	--------

36" x 80"	BC@1.35	Ea	150.00	50.80	200.80
-----------	---------	----	--------	-------	--------

Steel security screen door. Class I rated to withstand 300 pounds. All welded steel construction for strength and durability. Double lockbox with extension plate. Baked-on powder coating. Doors with specialty finishes and decorative or custom details will cost more.

36" x 80"	BC@1.35	Ea	123.00	50.80	173.80
-----------	---------	----	--------	-------	--------

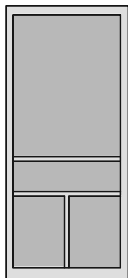

Doors, Storm

Craft@Hrs Unit Material Labor Total

Storm Doors Self-storing aluminum storm and screen doors. Pneumatic closer and sweep. Tempered safety glass. Maintenance-free finish. Push-button hardware. 1" x 2-1/8" frame size. Bronze or white. Includes screen.

30" x 80" x 1-1/4"	BC@1.45	Ea	112.00	54.60	166.60
32" x 80" x 1-1/4"	BC@1.45	Ea	131.00	54.60	185.60
36" x 80" x 1-1/4"	BC@1.45	Ea	131.00	54.60	185.60

Self-storing vinyl-covered wood storm doors. White vinyl-covered wood core. Push-button handle set. Self-storing window and screen. Single black closer.

30" x 80"	BC@1.45	Ea	115.00	54.60	169.60
32" x 80"	BC@1.45	Ea	115.00	54.60	169.60
34" x 80"	BC@1.45	Ea	115.00	54.60	169.60
36" x 80"	BC@1.45	Ea	115.00	54.60	169.60

Store-in-Door™ storm doors. 1-1/2"-thick polypropylene frame. Reversible hinge. Slide window or screen, completely concealed when not in use. Brass-finished keylock hardware system with separate color-matched deadbolt. Triple-fin door sweep. 2 color-matched closers. Full-length piano hinge. Flexible weather seal. White.

30" x 80", crossbuck style	BC@1.45	Ea	336.00	54.60	390.60
32" x 80", crossbuck style	BC@1.45	Ea	374.00	54.60	428.60
36" x 80", crossbuck style	BC@1.45	Ea	412.00	54.60	466.60
30" x 80", traditional style	BC@1.45	Ea	346.00	54.60	400.60
36" x 80", traditional style	BC@1.45	Ea	383.00	54.60	437.60

Aluminum and wood storm doors. Aluminum over wood core. Self-storing window and screen. Black lever handle set. Separate deadbolt. Single black closer. White finish. Traditional panel style.

30" x 80"	BC@1.45	Ea	207.00	54.60	261.60
32" x 80"	BC@1.45	Ea	195.00	54.60	249.60
36" x 80"	BC@1.45	Ea	195.00	54.60	249.60

Triple-track storm doors. Low-maintenance aluminum over solid wood core. Ventilates from top, bottom or both. Solid brass exterior handle. Color-matched interior handle. Separate deadbolt. 80" high. White, almond or bronze.

30" x 80"	BC@1.45	Ea	261.00	54.60	315.60
32" x 80"	BC@1.45	Ea	231.00	54.60	285.60
34" x 80"	BC@1.45	Ea	281.00	54.60	335.60
36" x 80"	BC@1.45	Ea	265.00	54.60	319.60

Colonial triple-track storm doors. 1-piece composite frame. 12-lite grille. Vents from top, bottom, or both. Solid-brass handle set with deadbolt security. Brass-finished sweep ensures tight seal across the entire threshold. Wood-grain finish. White, almond or sandstone.

32" x 80"	BC@1.45	Ea	368.00	54.60	422.60
-----------	---------	----	--------	-------	--------

Full-view brass all-season storm doors. Water-diverting rain cap. Brass-finished, color-matched sweep. One closer. Window and insect screen snap in and out. Reversible. Opens 180 degrees when needed. Separate deadbolt for added security. Tempered glass. Heavy-gauge one-piece 1" aluminum construction with reinforced corners and foam insulation.

36" x 80"	BC@1.45	Ea	378.00	54.60	432.60
-----------	---------	----	--------	-------	--------

Full-view aluminum storm doors. 1-1/2"-thick heavy-gauge aluminum frame with foam insulation. Extra perimeter weatherstripping and water-diverting rain cap. Solid brass handle set and double-throw deadbolt. Brass-finished sweep. Full-length, piano-style hinge. Reversible hinge for left- or right-side entry door handle. Two heavy-duty, color-matched closers. Solid brass perimeter locks. Insect screen. White, brown, green or almond.

30" x 80"	BC@1.45	Ea	277.00	54.60	331.60
32" x 80"	BC@1.45	Ea	236.00	54.60	290.60
36" x 80"	BC@1.45	Ea	308.00	54.60	362.60

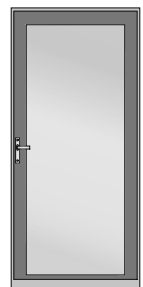
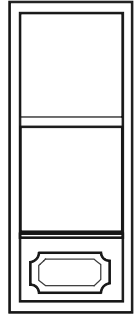

Doors, Security

Craft@Hrs Unit Material Labor Total

Full-view woodcore storm doors. Aluminum over solid wood core. Extra perimeter weatherstripping and water-diverting rain cap. Black push-button handle with night latch. Color-matched sweep. One heavy-duty closer. Snap-in, snap-out window and insect screen retainer system. White or bronze.

32" x 84"	BC@1.45	Ea	156.00	54.60	210.60
36" x 84"	BC@1.45	Ea	158.00	54.60	212.60

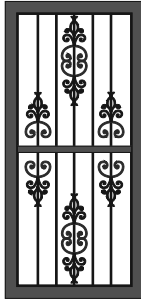

Security Storm Doors 16-gauge steel. Brass deadbolt lock. Tempered safety glass. Interchangeable screen panel. Heavy-gauge all-welded steel frame with mitered top. Double weatherstripped jamb and sweep. Tamper-resistant hinges with concealed interior screws. Heavy-duty pneumatic closer and safety wind chain. Prehung with reversible hinge.

30" x 80"	BC@1.45	Ea	404.00	54.60	458.60
32" x 80"	BC@1.45	Ea	355.00	54.60	409.60
36" x 80"	BC@1.45	Ea	392.00	54.60	446.60

Class II security doors. Rated to withstand 400 pounds. Double lockbox with extension plate. Decorative geometric ornaments. All welded steel construction. Expanded, galvanized metal screen. 3/4" square frame design.

32" x 80"	BC@1.45	Ea	124.00	54.60	178.60
36" x 80"	BC@1.45	Ea	127.00	54.60	181.60

Heavy-duty security door with screen. Right- or left-hand exterior mounting. All welded steel construction. Baked-on powder coating. Double lockbox with tamper-resistant extension plate. Uses standard 2-3/8" backset lock (not included). Galvanized perforated metal security screen. 1" x 1" door frame. 1" x 1-1/2" jambs, prehung on hinge side.

32" x 80"	BC@1.45	Ea	171.00	54.60	225.60
36" x 80"	BC@1.45	Ea	174.00	54.60	228.60

Paradise style security door. Five semi-concealed hinges. Heavy-duty deadbolt. All steel frame.

30" x 80"	BC@1.45	Ea	504.00	54.60	558.60
32" x 80"	BC@1.45	Ea	504.00	54.60	558.60
36" x 80"	BC@1.45	Ea	504.00	54.60	558.60

Folding security gates. Riveted 3/4" top and bottom channel. Gate pivots and folds flat to one side. Provides air circulation and positive visibility.

48" max width, 79" high	BC@1.25	Ea	114.00	47.10	161.10
-------------------------	---------	----	--------	-------	--------

Interior Slab Doors Slab doors are the door alone, as distinguished from prehung doors which are sold with jamb, hinges and trim attached and bored for the door latch. Interior doors are usually 1-3/8" thick and have a "hollow" core. A wood frame made from stiles and rails is filled with a matrix of corrugated paper and covered with a thin wood veneer. Stiles are vertical and every door has two, a lock stile and the hinge stile. Rails run horizontally at the top and bottom of the door. Flush doors are smooth and flat, with no decorative treatment.

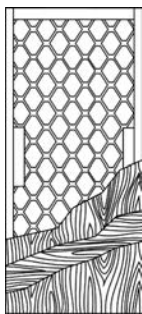

Flush hardboard interior doors. Hollow core. Not bored for lockset. Ready to paint or stain. 1-3/8" thick. Hardboard doors are made of composition wood veneer, usually the least expensive material available.

24" x 80"	BC@1.15	Ea	45.20	43.30	88.50
28" x 80"	BC@1.15	Ea	50.20	43.30	93.50
30" x 80"	BC@1.15	Ea	49.30	43.30	92.60
32" x 80"	BC@1.15	Ea	52.40	43.30	95.70
36" x 80"	BC@1.15	Ea	55.50	43.30	98.80

Flush birch interior doors. Hollow core. 1-3/8" thick. Wood veneer. Stainable and paintable. All wood stile and rail. Bored for lockset.

18" x 80"	BC@1.15	Ea	141.00	43.30	184.30
24" x 80"	BC@1.15	Ea	134.00	43.30	177.30
28" x 80"	BC@1.15	Ea	180.00	43.30	223.30
30" x 80"	BC@1.15	Ea	174.00	43.30	217.30
32" x 80"	BC@1.15	Ea	149.00	43.30	192.30
36" x 80"	BC@1.15	Ea	180.00	43.30	223.30

Doors, Interior Slab

	Craft@Hrs	Unit	Material	Labor	Total
Flush lauan interior doors. Hollow core. 1-3/8" thick. Wood veneer. Stainable and paintable. Lauan is a tropical hardwood like mahogany. All wood stile and rail.					
18" x 80"	BC@1.15	Ea	40.20	43.30	83.50
24" x 80"	BC@1.15	Ea	48.30	43.30	91.60
28" x 80"	BC@1.15	Ea	56.50	43.30	99.80
30" x 80"	BC@1.15	Ea	55.50	43.30	98.80
32" x 80"	BC@1.15	Ea	62.70	43.30	106.00
36" x 80"	BC@1.15	Ea	65.80	43.30	109.10
Flush oak interior doors. Hollow core. 1-3/8" thick. Wood veneer. Stainable and paintable. All wood stile and rail					
18" x 80"	BC@1.15	Ea	72.10	43.30	115.40
24" x 80"	BC@1.15	Ea	75.50	43.30	118.80
28" x 80"	BC@1.15	Ea	84.10	43.30	127.40
30" x 80"	BC@1.15	Ea	87.80	43.30	131.10
32" x 80"	BC@1.15	Ea	99.60	43.30	142.90
36" x 80"	BC@1.15	Ea	99.60	43.30	142.90
Flush hardboard solid core interior doors. Primed. 1-3/8" thick. Hardboard doors are made of composition wood veneer and are usually the least expensive.					
30" x 80"	BC@1.15	Ea	86.40	43.30	129.70
32" x 80"	BC@1.15	Ea	80.60	43.30	123.90
36" x 80"	BC@1.15	Ea	75.00	43.30	118.30
Flush lauan solid core interior doors. 1-3/8" thick. Stainable. Lauan doors are finished with a veneer of Philippine hardwood from the mahogany family.					
28" x 80"	BC@1.15	Ea	87.90	43.30	131.20
32" x 80"	BC@1.15	Ea	97.70	43.30	141.00
36" x 80"	BC@1.15	Ea	104.00	43.30	147.30
30" x 84"	BC@1.15	Ea	97.70	43.30	141.00
32" x 84"	BC@1.15	Ea	102.00	43.30	145.30
34" x 84"	BC@1.15	Ea	110.00	43.30	153.30
36" x 84"	BC@1.15	Ea	110.00	43.30	153.30
Flush birch solid core interior doors. 1-3/8" thick.					
24" x 80" (water heater closet door)	BC@1.15	Ea	188.00	43.30	231.30
32" x 80"	BC@1.15	Ea	141.00	43.30	184.30
36" x 80"	BC@1.15	Ea	154.00	43.30	197.30
Flush hardboard interior doors with lite. 1-3/8" thick.					
30" x 80" x 1-3/8"	BC@1.15	Ea	271.00	43.30	314.30
32" x 80" x 1-3/8"	BC@1.15	Ea	285.00	43.30	328.30
Flush hardboard walnut finish stile and rail hollow core doors. 1-3/8" thick.					
24" x 80"	BC@1.15	Ea	61.00	43.30	104.30
28" x 80"	BC@1.15	Ea	69.10	43.30	112.40
30" x 80"	BC@1.15	Ea	69.10	43.30	112.40
32" x 80"	BC@1.15	Ea	74.30	43.30	117.60
36" x 80"	BC@1.15	Ea	77.00	43.30	120.30
Interior Panel Doors Panel doors have decorative molding applied to the face.					
Hardboard 6-panel molded face interior doors. 1-3/8" thick. Molded and primed hardboard. Embossed simulated woodgrain. Hollow core. Ready to paint. Bored for lockset.					
24" x 80"	BC@1.15	Ea	45.20	43.30	88.50
28" x 80"	BC@1.15	Ea	47.30	43.30	90.60
30" x 80"	BC@1.15	Ea	110.00	43.30	153.30
32" x 80"	BC@1.15	Ea	52.40	43.30	95.70
36" x 80"	BC@1.15	Ea	56.70	43.30	100.00

Doors, Interior Panel

	Craft@Hrs	Unit	Material	Labor	Total
Lauan 6-panel molded face interior doors. Bored for latchset. 1-3/8" thick.					
24" x 80"	BC@1.15	Ea	52.80	43.30	96.10
28" x 80"	BC@1.15	Ea	57.70	43.30	101.00
30" x 80"	BC@1.15	Ea	59.80	43.30	103.10
32" x 80"	BC@1.15	Ea	60.60	43.30	103.90
36" x 80"	BC@1.15	Ea	62.90	43.30	106.20
Hardwood colonial 6-panel molded face interior doors. Primed. Solid core. 1-3/8" thick.					
24" x 80"	BC@1.15	Ea	189.00	43.30	232.30
28" x 80"	BC@1.15	Ea	184.00	43.30	227.30
30" x 80"	BC@1.15	Ea	172.00	43.30	215.30
32" x 80"	BC@1.15	Ea	188.00	43.30	231.30
36" x 80"	BC@1.15	Ea	217.00	43.30	260.30
Pine 6-panel stile and rail interior doors. Ready to paint or stain. 1-3/8" thick.					
24" x 80"	BC@1.15	Ea	129.00	43.30	172.30
28" x 80"	BC@1.15	Ea	135.00	43.30	178.30
30" x 80"	BC@1.15	Ea	141.00	43.30	184.30
32" x 80"	BC@1.15	Ea	147.00	43.30	190.30
36" x 80"	BC@1.15	Ea	154.00	43.30	197.30
Fir 1-panel stile and rail interior doors. 1-3/8" thick.					
28" x 80"	BC@1.15	Ea	303.00	43.30	346.30
30" x 80"	BC@1.15	Ea	307.00	43.30	350.30
32" x 80"	BC@1.15	Ea	309.00	43.30	352.30
Fir 3-panel stile and rail interior doors. 1-3/8" thick.					
28" x 80"	BC@1.15	Ea	371.00	43.30	414.30
30" x 80"	BC@1.15	Ea	371.00	43.30	414.30
32" x 80"	BC@1.15	Ea	373.00	43.30	416.30
Oak 6-panel stile and rail interior doors. Red oak. Double bevel hip raised panels. 1-3/8" thick.					
24" x 80"	BC@1.15	Ea	191.00	43.30	234.30
28" x 80"	BC@1.15	Ea	205.00	43.30	248.30
30" x 80"	BC@1.15	Ea	215.00	43.30	258.30
32" x 80"	BC@1.15	Ea	215.00	43.30	258.30
36" x 80"	BC@1.15	Ea	239.00	43.30	282.30
French stile and rail interior doors. Clear pine. Ready to paint or stain. 1-3/8" thick. Pre-masked tempered glass. French doors are mostly glass, with one, to as many as fifteen panes set in wood sash.					
24" x 80", 10 lite	BC@1.40	Ea	191.00	52.70	243.70
28" x 80", 10 lite	BC@1.40	Ea	181.00	52.70	233.70
30" x 80", 15 lite	BC@1.40	Ea	206.00	52.70	258.70
32" x 80", 15 lite	BC@1.40	Ea	213.00	52.70	265.70
36" x 80", 15 lite	BC@1.40	Ea	220.00	52.70	272.70
Half louver stile and rail interior doors. 1-3/8" thick. Louver doors include wood louvers that allow air to circulate but obscure vision, an advantage for enclosing a closet, pantry or water heater.					
24" x 80"	BC@1.15	Ea	369.00	43.30	412.30
28" x 80"	BC@1.15	Ea	376.00	43.30	419.30
30" x 80"	BC@1.15	Ea	383.00	43.30	426.30
32" x 80"	BC@1.15	Ea	395.00	43.30	438.30
36" x 80"	BC@1.15	Ea	398.00	43.30	441.30
Full louver doors. 1-3/8" thick, stile and rail interior doors.					
24" wide, 80" high	BC@1.15	Ea	195.00	43.30	238.30
30" wide, 80" high	BC@1.15	Ea	218.00	43.30	261.30
32" wide, 80" high	BC@1.15	Ea	333.00	43.30	376.30
36" wide, 80" high	BC@1.15	Ea	347.00	43.30	390.30

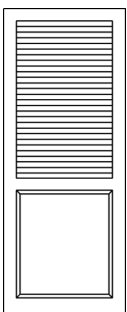

Doors, Interior Prehung

	Craft@Hrs	Unit	Material	Labor	Total
Stile and rail, louvered café doors, unfinished, per pair of doors. Add hardware from below.					
24" x 42"	BC@1.15	Pr	184.00	43.30	227.30
30" x 42"	BC@1.15	Pr	239.00	43.30	282.30
32" x 42"	BC@1.15	Pr	250.00	43.30	293.30
36" x 42"	BC@1.15	Pr	259.00	43.30	302.30
Satin brass café door pivot, 2-pak	—	Ea	8.22	—	8.22

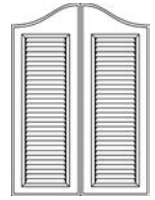

Interior Door Jambs Finger joint pine interior jamb set. Unfinished. Two 6'-8" legs and one 3' head.					
4-9/16" x 11/16"	BC@.500	Ea	33.20	18.80	52.00
5-1/4" x 11/16"	BC@.500	Ea	69.70	18.80	88.50
Solid clear pine interior jamb. Varnish or stain. Jamb set includes two 6'-8" legs and one 3' head.					
11/16" x 4-9/16" x 7' leg	BC@.210	Ea	10.30	7.91	18.21
11/16" x 4-9/16" x 3' head	BC@.090	Ea	11.90	3.39	15.29
11/16" x 4-9/16" jamb set	BC@.500	Ea	45.90	18.80	64.70
Door jamb set with hinges.					
80" x 4-9/16", per set	BC@.500	Ea	52.50	18.80	71.30
80" x 6-9/16", per set	BC@.500	Ea	56.10	18.80	74.90

Prehung Interior Doors Prehung doors are sold as a package with the door, jamb, hinges, and trim already assembled and the door bored for a latchset. Flush doors are smooth and flat, with no decorative treatment.

Flush prehung hardboard interior doors. Primed. 1-3/8" thick. Hollow core. Bored for lockset. Multi-finger jointed door jamb 11/16" x 4-9/16". 3 brass finish hinges 3-1/2" x 3-1/2".					
24" x 80"	BC@.750	Ea	94.60	28.20	122.80
28" x 80"	BC@.750	Ea	98.80	28.20	127.00
30" x 80"	BC@.750	Ea	103.00	28.20	131.20
32" x 80"	BC@.750	Ea	107.00	28.20	135.20
36" x 80"	BC@.750	Ea	111.00	28.20	139.20

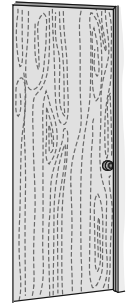

Flush prehung lauan interior doors. 1-3/8" thick. Hollow core. Bored for 2-1/8" lockset with 2-3/8" backset. Casing and lockset sold separately. Wood stile construction. Can be stained or finished naturally. Two brass hinges. Paint grade pine split jambs and 2-1/4" casings. 4" to 4-5/8" adjustable jamb.					
24" x 80"	BC@.750	Ea	138.00	28.20	166.20
28" x 80"	BC@.750	Ea	142.00	28.20	170.20
30" x 80"	BC@.750	Ea	145.00	28.20	173.20
32" x 80"	BC@.750	Ea	149.00	28.20	177.20
36" x 80"	BC@.750	Ea	154.00	28.20	182.20

Doors, Interior Prehung

Craft@Hrs Unit Material Labor Total

Interior prehung lauan heater closet doors.

24" x 60" BC@.750 Ea 136.00 28.20 164.20

Composite prehung panel interior doors. Hollow core. Primed. 1-3/8" thick. Bored for lockset. Multi-finger jointed door jamb 11/16" x 4-9/16". 3 brass finish hinges 3-1/2" x 3-1/2". Panel doors have raised decorative wood panels that resemble doors popular in colonial America. Two, 5, 6 or 9 panels are most common.

24" x 80" BC@.750 Ea 190.00 28.20 218.20

28" x 80" BC@.750 Ea 199.00 28.20 227.20

30" x 80" BC@.750 Ea 199.00 28.20 227.20

32" x 80" BC@.750 Ea 206.00 28.20 234.20

36" x 80" BC@.750 Ea 214.00 28.20 242.20

Mahogany colonial panel prehung interior doors. 11/16" x 4-9/16" jamb. Stain grade. Bored for lockset.

Hollow core. 1-3/8" thick.

18" x 80" BC@.750 Ea 343.00 28.20 371.20

24" x 80" BC@.750 Ea 384.00 28.20 412.20

28" x 80" BC@.750 Ea 416.00 28.20 444.20

30" x 80" BC@.750 Ea 398.00 28.20 426.20

32" x 80" BC@.750 Ea 405.00 28.20 433.20

36" x 80" BC@.750 Ea 442.00 28.20 470.20

6-panel colonist prehung interior doors. 6-9/16" jamb. Hollow core. Prefinished.

24" x 80" BC@.750 Ea 167.00 28.20 195.20

30" x 80" BC@.750 Ea 167.00 28.20 195.20

32" x 80" BC@.750 Ea 167.00 28.20 195.20

36" x 80" BC@.750 Ea 167.00 28.20 195.20

6-panel hardboard prehung interior doors. 4-9/16" adjustable split jambs. Hollow core. Paint grade casing applied. Pre-drilled for lockset. Ready to paint or gel stain.

24" x 80" BC@.750 Ea 119.00 28.20 147.20

28" x 80" BC@.750 Ea 122.00 28.20 150.20

30" x 80" BC@.750 Ea 125.00 28.20 153.20

32" x 80" BC@.750 Ea 130.00 28.20 158.20

36" x 80" BC@.750 Ea 134.00 28.20 162.20

6-panel hardboard prehung double interior doors. 1-3/8" thick. Flat jamb.

48" x 80" BC@1.25 Ea 294.00 47.10 341.10

60" x 80" BC@1.25 Ea 315.00 47.10 362.10

6-panel oak prehung interior doors. Hollow core. 1-3/8" thick. 11/16" x 4-9/16" clear pine jamb.

24" x 80" BC@.750 Ea 207.00 28.20 235.20

28" x 80" BC@.750 Ea 205.00 28.20 233.20

30" x 80" BC@.750 Ea 220.00 28.20 248.20

32" x 80" BC@.750 Ea 220.00 28.20 248.20

36" x 80" BC@.750 Ea 233.00 28.20 261.20

6-panel prehung interior double doors. Bored for lockset. Ready to paint or stain. 1-3/8" thick. 4-9/16" jambs.

4'0" x 6'8" BC@1.50 Ea 175.00 56.50 231.50

6'0" x 6'8" BC@1.50 Ea 180.00 56.50 236.50

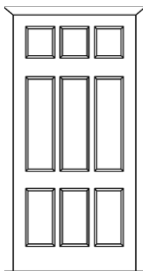

9 PANEL

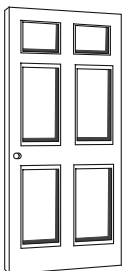

6 PANEL

Doors, Patio

	Craft@Hrs	Unit	Material	Labor	Total
6-panel hemlock prehung interior doors. Bored for lockset. Ready to paint or stain. 1-3/8" thick. 4-9/16" jambs.					
24" x 80"	BC@.750	Ea	303.00	28.20	331.20
28" x 80"	BC@.750	Ea	359.00	28.20	387.20
30" x 80"	BC@.750	Ea	317.00	28.20	345.20
32" x 80"	BC@.750	Ea	325.00	28.20	353.20
36" x 80"	BC@.750	Ea	331.00	28.20	359.20
2-panel knotty alder prehung interior doors. Bored for lockset. 1-3/8" thick.					
18" x 80"	BC@.750	Ea	465.00	28.20	493.20
24" x 80"	BC@.750	Ea	475.00	28.20	503.20
28" x 80"	BC@.750	Ea	475.00	28.20	503.20
30" x 80"	BC@.750	Ea	498.00	28.20	526.20
32" x 80"	BC@.750	Ea	498.00	28.20	526.20
36" x 80"	BC@.750	Ea	498.00	28.20	526.20
Add for 96" height	—	%	8.9	—	—
Pine full louver prehung interior doors. Ready to install. Provides ventilation while maintaining privacy. 11/16" x 4-9/16" clear face pine door jamb. 1-3/8" thick. Includes (3) 3-1/2" x 3-1/2" hinges with brass finish. Bored for lockset.					
24" x 80"	BC@.750	Ea	431.00	28.20	459.20
28" x 80"	BC@.750	Ea	488.00	28.20	516.20
30" x 80"	BC@.750	Ea	505.00	28.20	533.20
32" x 80"	BC@.750	Ea	451.00	28.20	479.20
36" x 80"	BC@.750	Ea	552.00	28.20	580.20
10-lite wood French prehung double interior doors. Pre-masked tempered glass for easy finishing. True divided light design. Ponderosa pine. 1-3/8" thick. French doors are mostly glass, with one, to as many as fifteen panes set in wood sash.					
60" x 80", unfinished	BC@1.25	Ea	2,440.00	47.10	2,487.10
64" x 80", unfinished	BC@1.25	Ea	2,270.00	47.10	2,317.10
72" x 80", unfinished	BC@1.25	Ea	2,140.00	47.10	2,187.10
60" x 80", stained	BC@1.25	Ea	3,060.00	47.10	3,107.10
64" x 80", stained	BC@1.25	Ea	2,890.00	47.10	2,937.10
78" x 80", stained	BC@1.25	Ea	2,760.00	47.10	2,807.10
Oak French prehung double interior doors. Bored for lockset. 1-3/8" thick.					
48" x 80"	BC@1.25	Ea	726.00	47.10	773.10
60" x 80"	BC@1.25	Ea	843.00	47.10	890.10
72" x 80"	BC@1.25	Ea	798.00	47.10	845.10
Patio Doors					
10-lite swinging patio double doors. White finish. Dual-glazed with clear tempered glass. Fully weatherstripped. Pre-drilled lock-bore.					
6'-0" wide x 6'-8" high	B1@3.58	Ea	566.00	122.00	688.00
Vinyl-clad hinged patio double doors, Frenchwood®, Andersen. White exterior. Perma-Shield® low-maintenance finish. Clear pine interior. 1-lite. 3-point locking system. Adjustable hinges with ball-bearing pivots. Low-E2 tempered insulating glass. Mortise and tenon joints.					
6'-0" x 6'-8"	B1@3.58	Ea	3,480.00	122.00	3,602.00
Center hinge 15-lite aluminum patio double doors. Sized for replacement. Unfinished clear pine interior. White extruded aluminum-clad exterior. Weatherstripped frame. Self-draining sill. Bored for lockset. 3/4" Low-E insulated safety glass.					
6'-0" x 6'-8"	B1@3.58	Ea	1,180.00	122.00	1,302.00
Aluminum inward swing 1-lite patio double doors. Low-E insulated safety glass. Clear wood interior ready to paint or stain.					
6'-0" x 6'-8"	B1@3.58	Ea	962.00	122.00	1,084.00
Aluminum inward swing 10-lite patio double doors. Unfinished interior. Low-E2 argon-filled insulated glass. Thermal-break sill. Bored for lockset. With head and foot bolts.					
6'-0" x 6'-8"	B1@3.58	Ea	1,020.00	122.00	1,142.00

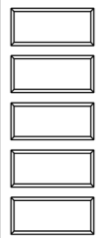

Doors, Patio

	Craft@Hrs	Unit	Material	Labor	Total
200 series Narroline™ sliding wood patio doors, Andersen. Dual-pane Low-E glass. Anodized aluminum track with stainless steel cap. With hardware and screen. White. 6'-0" x 6'-8"	B1@3.58	Ea	2,370.00	122.00	2,492.00
Vinyl-clad gliding patio doors, Andersen. White. Tempered 1" Low-E insulating glass. Anodized aluminum track. 6'-0" x 6'-8"	B1@3.58	Ea	906.00	122.00	1,028.00
10-lite sliding patio doors. Solid pine core. Weatherstripped on 4 sides of operating panels. Butcher block 4-1/2"-wide stiles and 9-1/2" bottom rail. 4-9/16" jamb width. White. Actual dimensions: 71-1/4" wide x 79-1/2" high. Pre-drilled lock-bore. 6'-0" wide x 6'-8" high	B1@3.58	Ea	401.00	122.00	523.00
Aluminum sliding patio doors. Unfinished interior. White aluminum-clad exterior. With lockset. Insulating Low-E2 glass. 6'-0" x 6'-8", 1 lite	B1@3.58	Ea	923.00	122.00	1,045.00
6'-0" x 6'-8", 15 lites	B1@3.58	Ea	859.00	122.00	981.00
Aluminum sliding patio doors. Insulating glass. Reversible, self-aligning ball bearing rollers. Zinc finish lock. With screen. By nominal width x height. Actual height and width are 1/2" less. 5' x 6'-8", bronze finish	B1@3.58	Ea	617.00	122.00	739.00
6' x 6'-8", bronze finish	B1@3.58	Ea	651.00	122.00	773.00
6' x 6'-8", mill finish	B1@3.58	Ea	481.00	122.00	603.00
Aluminum sliding patio doors. With screen. Insulated glass except as noted. Reversible, self-aligning ball bearing rollers. Zinc finish lock. By nominal width x height. Actual height and width are 1/2" less. 5'-0" x 6'-8", mill finish, single glazed	B1@3.58	Ea	263.00	122.00	385.00
5'-0" x 6'-8", white finish	B1@3.58	Ea	372.00	122.00	494.00
5'-0" x 8'-0", white finish, with grids	B1@3.58	Ea	423.00	122.00	545.00
6'-0" x 6'-8", bronze finish, single glazed	B1@3.58	Ea	438.00	122.00	560.00
6'-0" x 6'-8", bronze finish, with grids	B1@3.58	Ea	423.00	122.00	545.00
6'-0" x 6'-8", white finish, single glazed	B1@3.58	Ea	376.00	122.00	498.00
8'-0" x 8'-0", white finish	B1@4.60	Ea	468.00	157.00	625.00
Screen for sliding or swinging patio doors. 72-1/2" wide x 6'8" high. Inswing/Outswing, French door, white	B1@.250	Ea	138.00	8.53	146.53
Traditional, aluminum frame, fiberglass screen	B1@.250	Ea	136.00	8.53	144.53
Retractable, for in-swing door, white 36" x 80"	B1@.250	Ea	120.00	8.53	128.53
Vinyl sliding patio doors. Includes screen. Low-E insulating glass. 5'-0" x 6'-8"	B1@3.58	Ea	932.00	122.00	1,054.00
5'-0" x 6'-8", with internal mini-blinds	B1@3.58	Ea	1,290.00	122.00	1,412.00
6'-0" x 6'-8"	B1@3.58	Ea	881.00	122.00	1,003.00
6'-0" x 6'-8" with grid	B1@3.58	Ea	1,130.00	122.00	1,252.00
6'-0" x 6'-8" with internal mini-blinds	B1@3.58	Ea	1,310.00	122.00	1,432.00
1-lite swinging prehung steel patio double doors. Polyurethane core. High-performance weatherstrip. Adjustable thermal-break sill. Non-yellowing frame and grille. Inward swing. 6'-0" x 6'-8"	B1@3.58	Ea	392.00	122.00	514.00

Doors, Folding

	Craft@Hrs	Unit	Material	Labor	Total
1-lite swinging steel patio double door with internal mini-blinds. Prehung. Double-pane insulated safety glass.					
6'-0" x 6'-8", outward swing	B1@3.58	Ea	640.00	122.00	762.00
6'-0" x 6'-8", inward swing, with brick mold	B1@3.58	Ea	720.00	122.00	842.00
6'-0" x 6'-8", outward swing, Dade County-approved (high wind)	B1@3.58	Ea	1,230.00	122.00	1,352.00
10-lite swinging steel patio double doors. Inward swing. Insulated Low-E glass.					
5'-0" x 6'-8"	B1@3.58	Ea	1,290.00	122.00	1,412.00
6'-0" x 6'-8"	B1@3.58	Ea	1,290.00	122.00	1,412.00
10-lite venting steel patio double doors. Inward swing. Insulated glass.					
6'-0" x 6'-8"	B1@3.58	Ea	792.00	122.00	914.00
8'-0" x 6'-8"	B1@3.58	Ea	892.00	122.00	1,014.00
15-lite swinging steel patio double doors. Inward swing					
5'-0" x 6'-8", insulated glass	B1@3.58	Ea	1,130.00	122.00	1,252.00
6'-0" x 6'-8", Low-E insulated glass	B1@3.58	Ea	1,130.00	122.00	1,252.00
6'-0" x 6'-8", single glazed	B1@3.58	Ea	1,030.00	122.00	1,152.00
15-lite prehung swinging fiberglass patio double doors. Outward swing. Insulated glass. Adjustable mill finish thermal-break threshold					
6'-0" x 6'-8"	B1@3.58	Ea	1,530.00	122.00	1,652.00

Accordion Folding Doors Vertical embossed surface. Includes hardware. Fully assembled. Hung in a cased opening.

32" x 80" vinyl, natural color, Horizon	BC@.750	Ea	40.60	28.20	68.80
32" x 80" vinyl, white, Horizon	BC@.750	Ea	30.40	28.20	58.60
32" x 80" vinyl, fruitwood color, Encore	BC@.750	Ea	87.60	28.20	115.80
32" x 80" vinyl, white, Horizon	BC@.750	Ea	88.20	28.20	116.40
32" x 80" vinyl, oak color, Horizon	BC@.750	Ea	93.70	28.20	121.90
32" x 80" vinyl, white, Capri	BC@.750	Ea	262.00	28.20	290.20
32" x 80" frosted Plexiglas, asstd colors	BC@.750	Ea	279.00	28.20	307.20
36" x 80" vinyl, oak color, Via	BC@.750	Ea	38.90	28.20	67.10
36" x 80" vinyl, white, Via	BC@.750	Ea	45.20	28.20	73.40
36" x 80" vinyl, white, Contempra	BC@.750	Ea	59.90	28.20	88.10
36" x 80" vinyl, white, Oakmont	BC@.750	Ea	75.50	28.20	103.70
36" x 96" vinyl, oak color, Express One	BC@.750	Ea	170.00	28.20	198.20
36" x 96" vinyl, white, Express One	BC@.750	Ea	168.00	28.20	196.20
48" x 96" vinyl, oak color, Express One	BC@.750	Ea	194.00	28.20	222.20
48" x 96" vinyl, white, Express One	BC@.750	Ea	192.00	28.20	220.20
Folding door lock.					
Door lock	BC@.250	Ea	9.83	9.42	19.25

Pet Doors Entrance doors, lockable, swinging, aluminum frame with security panel

Small, 5" x 7" opening	BC@.800	Ea	36.50	30.10	66.60
Medium, 7" x 11-1/4" opening	BC@.800	Ea	39.90	30.10	70.00
Large, 10-1/2" x 15" opening	BC@.850	Ea	51.00	32.00	83.00
Super large, 15" x 20" opening	BC@.850	Ea	73.00	32.00	105.00
Entrance doors, lockable, swinging, aluminum frame with security panel, dual flap, insulated					
Small, 5" x 9-1/4" opening	BC@.800	Ea	90.60	30.10	120.70
Medium, 7-1/4" x 13" opening	BC@.800	Ea	97.40	30.10	127.50
Large, 9-3/4" x 17" opening	BC@.850	Ea	101.00	32.00	133.00
Super large, 15" x 23-1/2" opening	BC@.850	Ea	169.00	32.00	201.00

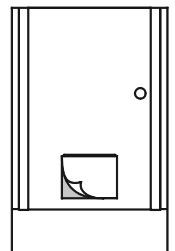

Doors, Closet

	Craft@Hrs	Unit	Material	Labor	Total
Entrance pet doors, lockable, with wall installation kit, swinging, aluminum frame with security panel, dual flap, insulated. Labor for creating wall opening not included					
Small, 5" x 9-1/4" opening	BC@.800	Ea	115.00	30.10	145.10
Medium, 7-1/4" x 13" opening	BC@.800	Ea	120.00	30.10	150.10
Large, 9-3/4" x 17" opening	BC@.850	Ea	132.00	32.00	164.00
Super large, 15" x 23-1/2" opening	BC@.850	Ea	202.00	32.00	234.00
Sliding screen or patio doors, adjustable full length 1/2" panel, 80" high, "Lexan" plastic above lockable, swinging PVC door, aluminum frame					
For cats and miniature dogs, panel is 11-1/2" wide with					
5" x 7-1/2" door	BC@.500	Ea	82.10	18.80	100.90
For small dogs, panel is 15" wide with					
8-1/2" x 12-1/2" door	BC@.500	Ea	115.00	18.80	133.80
For medium and large dogs, panel is 18" wide with					
11-1/2" x 16-1/2" door	BC@.500	Ea	150.00	18.80	168.80
Pet screen, vinyl coated 48" x 84"					
Resists tears and punctures	BC@.500	Ea	20.50	18.80	39.30
Pet grill, steel, 36" x 31-3/8"	BC@.250	Ea	53.50	9.42	62.92

Bypass Closet Doors Bypass closet doors slide left or right on an overhead track, never revealing more than one-half of the interior.

White bypass closet doors. Prefinished white vinyl-covered hardboard panels instead of mirrors. White steel frame. Jump-proof bottom track. 1-1/2" dual race ball bearing wheels. Injection-molded top guides. Dimensions are width x height. Per pair of doors.

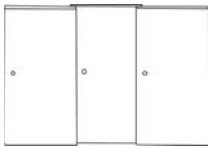

48" x 80"	BC@.750	Ea	76.00	28.20	104.20
60" x 80"	BC@1.00	Ea	92.90	37.70	130.60
72" x 80"	BC@1.00	Ea	103.00	37.70	140.70
48" x 96"	BC@.750	Ea	107.00	28.20	135.20
60" x 96"	BC@1.00	Ea	125.00	37.70	162.70
72" x 96"	BC@1.00	Ea	146.00	37.70	183.70

Economy mirrored bypass closet doors. Gold finished steel. Plate mirror with double strength glass.

Bottom rail with jump-proof track. Dimensions are width x height. Per pair of doors.

47" x 80"	BC@.750	Ea	97.80	28.20	126.00
59" x 80"	BC@1.00	Ea	126.00	37.70	163.70
71" x 80"	BC@1.00	Ea	138.00	37.70	175.70
95" x 80"	BC@1.25	Ea	220.00	47.10	267.10

Good quality mirrored bypass closet doors. White frame. Safety-backed mirror. Dimensions are width x height. Per pair of doors.

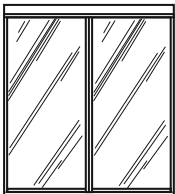

48" x 80", silver nickel mirror	BC@.750	Ea	134.00	28.20	162.20
60" x 80", silver nickel mirror	BC@1.00	Ea	164.00	37.70	201.70
72" x 80", silver nickel mirror	BC@1.00	Ea	192.00	37.70	229.70
48" x 80", trimline bronze mirror door	BC@.750	Ea	251.00	28.20	279.20
60" x 80", trimline bronze mirror door	BC@1.00	Ea	278.00	37.70	315.70
72" x 80", trimline bronze mirror door	BC@1.00	Ea	307.00	37.70	344.70
48" x 80", satin mirror door	BC@.750	Ea	213.00	28.20	241.20
60" x 80", satin mirror door	BC@1.00	Ea	242.00	37.70	279.70
72" x 80", satin mirror door	BC@1.00	Ea	270.00	37.70	307.70

Beveled mirror bypass closet doors. 1/2" bevel on both sides of glass. Safety-backed mirror. Includes hardware. Dimensions are width x height. Per pair of doors.

48" x 80"	BC@.750	Ea	151.00	28.20	179.20
60" x 80"	BC@1.00	Ea	173.00	37.70	210.70
72" x 80"	BC@1.00	Ea	227.00	37.70	264.70
96" x 80"	BC@1.25	Ea	283.00	47.10	330.10

Doors, Closet

Craft@Hrs Unit Material Labor Total

Premium mirrored bypass closet doors. Brushed nickel. Anodized aluminum finish with color-coordinated glazing vinyl. Color-matched mirror handles. "Select" quality 3mm plate mirror. Jump-proof bottom track and 1-1/2" dual race ball bearing wheels. Mitered frame corners. Dimensions are width x height. Per pair of doors.

48" x 81"	BC@.750	Ea	252.00	28.20	280.20
60" x 81"	BC@1.00	Ea	280.00	37.70	317.70
72" x 81"	BC@1.00	Ea	310.00	37.70	347.70
96" x 81"	BC@1.25	Ea	358.00	47.10	405.10

Bypass door accessories

Bumper	BC@.175	Ea	4.29	6.59	10.88
Carpet riser	BC@.175	Ea	3.73	6.59	10.32
Guide	BC@.175	Ea	3.93	6.59	10.52

Bi-Fold Closet Doors Bi-fold closet doors fold in half when open, revealing nearly the full interior.

Lauan bi-fold flush closet doors. 1-3/8" thick. 2 prehinged panels. Ready to paint, stain, or varnish.

24" x 80"	BC@.700	Ea	44.80	26.40	71.20
30" x 80"	BC@.700	Ea	50.80	26.40	77.20
32" x 80"	BC@.700	Ea	53.30	26.40	79.70
36" x 80"	BC@.700	Ea	56.90	26.40	83.30

Primed hardboard bi-fold flush closet doors. 1-3/8" thick. 2 prehinged panels.

24" x 80"	BC@.700	Ea	112.00	26.40	138.40
30" x 80"	BC@.700	Ea	114.00	26.40	140.40
32" x 80"	BC@.700	Ea	122.00	26.40	148.40
36" x 80"	BC@.700	Ea	116.00	26.40	142.40

4-panel birch bi-fold flush closet doors. Wood stile and rail construction. 1-3/8" thick. Open left or right.

Includes track and hardware.

24" x 80"	BC@.700	Ea	44.50	26.40	70.90
30" x 80"	BC@.700	Ea	51.70	26.40	78.10
36" x 80"	BC@.700	Ea	58.90	26.40	85.30
48" x 80"	BC@.800	Ea	87.80	30.10	117.90

4-panel lauan flush bi-fold closet doors. Wood stile and rail construction. 1-3/8" thick. Open left or right.

Includes track and hardware.

48" x 80"	BC@.800	Ea	70.40	30.10	100.50
-----------	---------	----	-------	-------	--------

4-panel red oak flush bi-fold closet doors. Wood stile and rail construction. 1-3/8" thick. Open left or right.

Includes track and hardware.

24" x 80"	BC@.700	Ea	64.20	26.40	90.60
30" x 80"	BC@.700	Ea	71.50	26.40	97.90
36" x 80"	BC@.700	Ea	81.80	26.40	108.20
48" x 80"	BC@.800	Ea	119.00	30.10	149.10

Pine colonial panel bi-fold doors. Includes hardware and track. Can be painted or stained. Two hinged panels.

24" x 80"	BC@.700	Ea	90.40	26.40	116.80
30" x 80"	BC@.700	Ea	98.20	26.40	124.60
32" x 80"	BC@.700	Ea	105.00	26.40	131.40

Clear pine 2-panel colonial bi-fold doors. Clear pine. Recessed rails. Unfinished. Open left or right.

Includes all hardware and track. Two hinged panels.

24" x 80"	BC@.700	Ea	159.00	26.40	185.40
30" x 80"	BC@.700	Ea	165.00	26.40	191.40
32" x 80"	BC@.700	Ea	171.00	26.40	197.40
36" x 80"	BC@.700	Ea	179.00	26.40	205.40

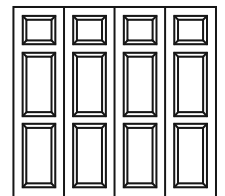
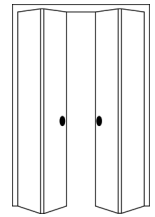

Doors, Closet

Craft@Hrs Unit Material Labor Total

Oak panel bi-fold doors. Includes track and hardware. 1-3/8" thick. Ready to finish. Classic. Two hinged panels.

24" x 80"	BC@.700	Ea	168.00	26.40	194.40
30" x 80"	BC@.700	Ea	180.00	26.40	206.40
36" x 80"	BC@.700	Ea	200.00	26.40	226.40

Pine louver over louver bi-fold doors. 1-1/8" thick ponderosa pine. 3-11/16" wide rails. 1-1/4" wide stiles. Two prehung panels. Unfinished.

24" x 80"	BC@.700	Ea	69.80	26.40	96.20
30" x 80"	BC@.700	Ea	76.30	26.40	102.70
32" x 80"	BC@.700	Ea	86.50	26.40	112.90
36" x 80"	BC@.700	Ea	91.50	26.40	117.90

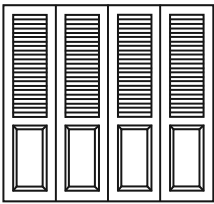

Pine louver over panel bi-fold doors. Recessed rails. Open left or right. 1/2" swing space. Two prehung panels. Includes track and hardware. Unfinished stain grade.

24" x 80"	BC@.700	Ea	69.40	26.40	95.80
30" x 80"	BC@.700	Ea	108.00	26.40	134.40
36" x 80"	BC@.700	Ea	123.00	26.40	149.40

Bi-fold door hardware

Bi-fold hinge	BC@.175	Ea	4.55	6.59	11.14
Carpet riser	BC@.175	Ea	2.71	6.59	9.30
Hardware set	BC@.175	Ea	9.98	6.59	16.57
48" track	—	Ea	30.90	—	30.90
60" track	—	Ea	31.70	—	31.70
72" track	—	Ea	33.70	—	33.70

Mirrored Bi-Fold Closet Doors Framed bi-fold mirror doors. White frame. Top-hung with single wheel top hanger. Snap-in bottom guide and fascia. Low rise bottom track. Non-binding door operation.

Reversible top and bottom track. 3 mm safety-backed mirror. Two hinged panels.

24" x 80"	BC@.700	Ea	117.00	26.40	143.40
30" x 80"	BC@.700	Ea	132.00	26.40	158.40
36" x 80"	BC@.700	Ea	146.00	26.40	172.40

Bevel edge bi-fold mirror doors. 1/2" vertical bevel with bearing hinges. White finished steel frame with safety-backed mirror. Includes hardware. Full access to closet opening. Reversible high- and low-profile top and bottom tracks. Two hinged panels.

24" x 80"	BC@.700	Ea	134.00	26.40	160.40
30" x 80"	BC@.700	Ea	147.00	26.40	173.40

Frameless bi-fold mirror doors. Frameless style maximizes the mirror surface. Beveled edge glass. All preassembled hinges. Safety-reinforced mirror backing. Two hinged panels. Includes hardware.

36" x 80"	BC@.700	Ea	121.00	26.40	147.40
30" x 80"	BC@.700	Ea	146.00	26.40	172.40
36" x 80"	BC@.700	Ea	162.00	26.40	188.40

Chrome bi-fold mirror doors. Two hinged panels. Includes hardware.

24" x 80"	BC@.700	Ea	210.00	26.40	236.40
30" x 80"	BC@.700	Ea	223.00	26.40	249.40
36" x 80"	BC@.700	Ea	239.00	26.40	265.40

Drafting

Craft@Hrs Unit Material Labor Total

Drafting Per SF of floor area, architectural only, not including engineering fees. See also Architectural Illustrations and Blueprinting. Typical prices.

Apartments	—	SF	—	—	2.28
Warehouses and storage buildings	—	SF	—	—	2.02
Office buildings	—	SF	—	—	3.97
Residences					
Minimum quality tract work	—	SF	—	—	3.08
Typical work	—	SF	—	—	3.81
Detailed jobs, exposed woods, hillsides	—	SF	—	—	4.76

Drainage Piping Corrugated plastic drainage pipe, plain or perforated and snap-on fittings. Installed in trenches or at foundation footings. No excavation, gravel or backfill included.

Polyethylene pipe

3" pipe perforated	BL@.010	LF	.85	.31	1.16
4" pipe solid	BL@.010	LF	.71	.31	1.02
6" pipe slotted	BL@.012	LF	2.20	.37	2.57

Corrugated drain snap pipe fittings

3" internal coupling	P1@.100	Ea	2.69	3.72	6.41
3" perforated end cap	P1@.055	Ea	2.91	2.05	4.96
3" snap adapter	P1@.100	Ea	5.89	3.72	9.61
3" corrugated x smooth adapter	P1@.100	Ea	3.00	3.72	6.72
4" internal coupling	P1@.100	Ea	3.99	3.72	7.71
4" universal adapter	P1@.100	Ea	5.82	3.72	9.54
4" x 3" reducer	P1@.100	Ea	4.99	3.72	8.71
4" snap adapter	P1@.100	Ea	5.01	3.72	8.73
6" snap adapter	P1@.110	Ea	13.00	4.09	17.09
6" x 4" reducer	P1@.110	Ea	7.94	4.09	12.03
6" snap coupling	P1@.110	Ea	6.21	4.09	10.30
6" wye	P1@.150	Ea	9.25	5.58	14.83
6" tee	P1@.150	Ea	22.20	5.58	27.78
6" blind tee	P1@.150	Ea	18.00	5.58	23.58
6" split end cap	P1@.060	Ea	5.85	2.23	8.08

Filter sock sieve. Keeps soil out of perforated pipe. Reduces need for aggregate filters. By pipe size. Per linear foot of sock.

3", 10' length	P1@.006	LF	.56	.22	.78
4", 10' length	P1@.007	LF	.60	.26	.86
4", 100' length	P1@.007	LF	.22	.26	.48

Rock or sand fill for drainage systems. Labor cost is for spreading base and covering pipe. 3 mile haul, dumped on site and placed by wheelbarrow.

Crushed stone (1.4 tons per CY)					
3/4" (Number 3)	BL@.700	CY	31.70	21.40	53.10
1-1/2" (Number 2)	BL@.700	CY	30.40	21.40	51.80
Crushed slag (1.86 tons per CY)					
3/4"	BL@.700	CY	33.00	21.40	54.40
Sand (1.35 tons per CY)	BL@.360	CY	39.00	11.00	50.00

Draperies

Craft@Hrs Unit Material Labor Total

Precast Residential Rain Drain System System includes 5 interlocking tongue and groove connection channels with galvanized steel slotted grate, one meter long each, 4" outlet and closing end caps, catch basin, and 4" PVC pipe outlet. Channel has 4" internal width. System withstands imposed loadings up to 3,500 lbs. Set in concrete, not including concrete or forming costs.



System components

1 meter channel with grate	—	Ea	102.00	—	102.00
4" outlet cap	—	Ea	9.04	—	9.04
4" closed end cap	—	Ea	9.03	—	9.03
Catch basin with PVC trash bucket and steel grating	—	Ea	121.00	—	121.00
4" PVC pipe outlet	—	Ea	28.10	—	28.10
Typical 5 meter rain drain system	BL@4.0	Ea	679.00	122.00	801.00

Draperies, Custom, Subcontract Custom draperies include 4" double hems and headers, 1-1/2" side hems, and weighted corners. Finished sizes allow 4" above, 4" below (except for sliding glass openings), and 5" on each side of wall openings. Prices are figured at one width, 48" of fabric, pleated to 16". Costs listed include fabric, full liner, manufacturing, all hardware, and installation. Add 50% per LF of width for jobs outside working range of metropolitan centers. Use \$300 as a minimum job charge.

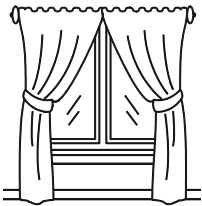

Minimum quality, 200% fullness, average is 6 panels of fabric, limited choice of fabric styles, colors, and textures

To 95" high	—	LF	—	—	50.80
To 68" high	—	LF	—	—	47.70
To 54" high	—	LF	—	—	46.10

Good quality, fully lined, 250% fullness, average is 5 panels of fabric, better selection of fabric styles, colors, and textures, weighted seams

To 95" high	—	LF	—	—	121.00
To 84" high	—	LF	—	—	116.00
To 68" high	—	LF	—	—	108.00
To 54" high	—	LF	—	—	102.00
To 44" high	—	LF	—	—	98.10
Deduct for multi-unit jobs	—	%	—	—	-25.0
Add for insulated fabrics or liners					
Pleated shade liner	—	SY	—	—	33.50
Thermal liner	—	SY	—	—	36.00

Better quality, fully lined, choice of finest fabric styles, colors, and textures, does not include special treatments such as elaborate swags, or custom fabrics

To 95" high	—	LF	—	—	149.00
To 84" high	—	LF	—	—	144.00
To 68" high	—	LF	—	—	128.00
To 54" high	—	LF	—	—	119.00
To 44" high	—	LF	—	—	112.00

Electrical Work, Subcontract Costs listed below are for wiring new residential and light commercial buildings with Romex cable and assume circuit lengths averaging 40 feet. If flex cable is required, add \$15.00 for 15 amp circuits and \$35 for 20 amp circuits. No fixtures or appliances included except as noted. Work on second and higher floors may cost 25% more. Work performed by a qualified subcontractor.



Rule of thumb: Total cost for electrical work, performed by a qualified subcontractor, per SF of floor area. Includes service entrance, outlets, switches, basic lighting fixtures and connecting appliances only.

All wiring and fixtures	—	SF	—	—	6.22
Lighting fixtures only (no wiring)	—	SF	—	—	1.80

Electrical Work, Subcontract

	Craft@Hrs	Unit	Material	Labor	Total
Air conditioners (with thermostat)					
Central, 2 ton (220 volt)	—	LS	—	—	854.00
First floor room (115 volt)	—	LS	—	—	255.00
Second floor room (115 volt)	—	LS	—	—	514.00
Add for thermostat on second floor	—	LS	—	—	174.00
Alarms. See also Security Alarms					
Fire or smoke detector, wiring and outlet box only	—	LS	—	—	193.00
Add for detector unit	—	LS	—	—	98.00
Bathroom fixtures, wiring only, no fixtures or equipment included					
Mirror lighting (valance or side lighted mirrors)	—	LS	—	—	173.00
Sauna heater (40 amp branch circuit)	—	LS	—	—	515.00
Steam bath generator	—	LS	—	—	514.00
Heat lamp with timer wall switch	—	LS	—	—	255.00
Whirlpool bath system and wall switch	—	LS	—	—	428.00
Clock outlets (recessed)	—	LS	—	—	129.00
Closet lighting					
Ceramic "pull chain" ceiling fixture	—	LS	—	—	130.00
Switch-operated fixture with wall switch	—	LS	—	—	173.00
Clothes dryers					
Gas dryer, receptacle only	—	LS	—	—	174.00
Direct connection for up to 5,760 watt (30 amp) electric dryer, 220 volt	—	LS	—	—	255.00
Direct connection for over 5,760 watt (40 amp) electric dryer, 220 volt	—	LS	—	—	301.00
Clothes washers (115 volt)	—	LS	—	—	127.00
Dishwashers	—	LS	—	—	174.00
Door bells, rough wiring, front and rear with transformer					
Add the cost of two push-buttons and the chime	—	LS	—	—	254.00
Fans (exhaust)					
Attic fans (wiring only)	—	LS	—	—	172.00
Bathroom fans (includes 70 CFM fan)	—	LS	—	—	252.00
Garage fans (wiring only)	—	LS	—	—	176.00
Kitchen fans (includes 225 CFM fan)	—	LS	—	—	343.00
Furnace wiring and blower hookup only	—	LS	—	—	208.00
Garage door opener, wiring and hookup only	—	LS	—	—	177.00
Garbage disposers, wiring, switch and connection only					
No disposer included	—	LS	—	—	216.00
Grounding devices (see also Lightning protection systems below)					
Grounding entire electrical system	—	LS	—	—	247.00
Grounding single appliance	—	LS	—	—	106.00
Ground fault circuit interrupter (GFCI), rough and finish wiring					
Includes outlet box and GFCI	—	LS	—	—	216.00
Heaters					
Baseboard (115 volt) per branch circuit	—	LS	—	—	174.00
Bathroom (ceiling type) wiring, switch connection (with GFCI) only	—	LS	—	—	202.00
Ceiling heat system (radiant-resistance type) 1,000 watt, 120 volt, per branch circuit, including thermostat	—	LS	—	—	392.00
Space heating (flush in-wall type) up to 2,000 watt, 220 volt	—	LS	—	—	358.00
Humidifiers, central	—	LS	—	—	174.00

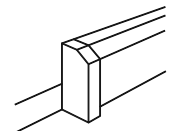
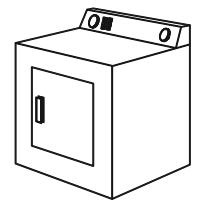
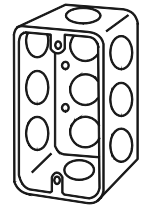

Electrical Work, Subcontract

	Craft@Hrs	Unit	Material	Labor	Total
Exterior lamp posts, wiring and hookup only, to 25' Using buried wire and conduit	—	LS	—	—	1,020.00
Lighting fixture outlets (rough wiring and box only)					
Ceiling	—	Ea	—	—	84.70
Floor	—	Ea	—	—	129.00
Set in concrete	—	Ea	—	—	171.00
Set in masonry	—	Ea	—	—	171.00
Underground	—	Ea	—	—	224.00
Valance	—	Ea	—	—	102.00
Wall outlet	—	Ea	—	—	84.70
Lightning protection systems (static electric grounding system) Residential, ridge protection including one chimney and connected garage (houses with cut-up roofs will cost more)					
Typical home system	—	LS	—	—	3,640.00
Barns and light commercial buildings	—	LS	—	—	7,120.00
Ovens, wall type (up to 10' of wiring and hookup only), 220 volt					
To 4,800 watts (20 amp)	—	LS	—	—	208.00
4,800 to 7,200 watts (30 amp)	—	LS	—	—	243.00
7,200 to 9,600 watts (40 amp)	—	LS	—	—	316.00
Ranges, (up to 10' of wiring and hookup only), 220 volt					
Countertop type					
To 4,800 watts (20 amp)	—	LS	—	—	170.00
4,800 to 7,200 watts (30 amp)	—	LS	—	—	244.00
7,200 to 9,600 watts (40 amp)	—	LS	—	—	316.00
Freestanding type (50 amp)	—	LS	—	—	349.00
Receptacle outlets (rough wiring, box, receptacle and plate)					
Ceiling	—	Ea	—	—	70.00
Countertop wall	—	Ea	—	—	76.00
Floor outlet	—	Ea	—	—	104.00
Split-wired	—	Ea	—	—	131.00
Standard indoor, duplex wall outlet	—	Ea	—	—	70.00
Waterproof, with ground fault circuit	—	Ea	—	—	112.00
Refrigerator or freezer wall outlet	—	Ea	—	—	83.60
Service entrance connections, complete (panel box hookup but no wiring)					
100 amp service including meter socket, main switch, GFCI and 5 single pole breakers in 20 breaker space exterior panel box	—	LS	—	—	1,320.00
200 amp service including meter socket, main switch, 2 GFCI and 15 single pole breakers in 40 breaker space exterior panel box	—	LS	—	—	2,180.00
Sub-panel connections (panel box hookup but no wiring)					
40 amp circuit panel including 12 single pole breakers in 12 breaker indoor panel box	—	LS	—	—	491.00
50 amp circuit panel including 16 single pole breakers in 16 breaker indoor panel box	—	LS	—	—	523.00
Sump pump connection including 15' of underground conduit	—	Ea	—	—	250.00
Switches (includes rough wiring, box, switch and plate)					
Dimmer	—	Ea	—	—	73.60
Lighted	—	Ea	—	—	73.70
Quiet	—	Ea	—	—	58.90
Mercury	—	Ea	—	—	73.50
Standard indoor wall switch	—	Ea	—	—	57.70
Stair-wired (3 way)	—	Ea	—	—	155.00
Waterproof	—	Ea	—	—	125.00
Television outlet wiring (300 ohm wire)	—	Ea	—	—	58.90

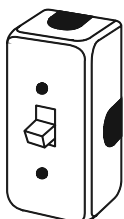
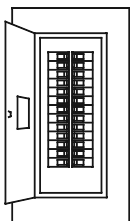
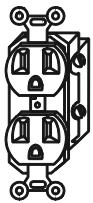

Computer Wiring & Network Setup

	Craft@Hrs	Unit	Material	Labor	Total
Trash compactor, 15" (includes compactor installed under counter and wiring)					
Standard	—	LS	—	—	657.00
Deluxe	—	LS	—	—	768.00
Vacuuming system, central					
Central unit hookup	—	LS	—	—	146.00
Remote vacuum outlets					
Receptacle wiring only	—	Ea	—	—	70.00
Water heaters					
(up to 10' of wiring and hookup only), 220 volt	—	LS	—	—	218.00
Water pumps, domestic potable water					
Connection only	—	LS	—	—	155.00

Residential computer wiring and network setup These costs are based on work done with wall cavities exposed. Labor costs in existing dwellings will be up to four times higher if cable has to be fished through enclosed walls. Single story homes use stranded wire. Multi story homes use solid wire on vertical runs. Includes normal (5%) waste. Costs assume cable runs terminate at the point of phone or cable service entry and that connections are made at a wall-mounted punch down block with RJ45 connectors. The local building code may require wire runs in conduit or use of plenum type cable.

Network cable, twisted pair category 5e, rated for 350 Mbps, material price based on 1,000' rolls. Add the cost of conduit, if required. Costs per linear foot of cable run.

4 pair UTP PVC stranded wire	BE@.008	LF	.18	.33	.51
4 pair UTP PVC solid wire	BE@.008	LF	.18	.33	.51
Add for plenum grade wire	—	%	60.0	—	—

Termination to structured cable panel. Includes structured cable panel with telephone, data and video connectors for 6, 12 or 18 stations. Also includes RJ45 keystone jack and wall plate at the room/station end.

12 station termination	BE@1.40	Ea	200.00	57.40	257.40
18 station termination	BE@2.10	Ea	225.00	86.20	311.20
24 station termination	BE@2.80	Ea	259.00	115.00	374.00

Cable testing using a dedicated cable tester

Shielded/Unshielded twisted pair, per cable	E4@.125	Ea	—	6.42	6.42
---	---------	----	---	------	------

Distribution of Internet connection to network switch or router. Includes 10/100 network switch/wireless router and patch cables

6 station connection	BE@.166	Ea	101.00	6.81	107.81
12 station connection	BE@.333	Ea	105.00	13.70	118.70
18 station connection	BE@.500	Ea	154.00	20.50	174.50

Wireless access points. Preferred location is one foot below the ceiling on a small shelf. Each access point counts as one station termination and connection. Add the cost of network cable wiring to the access point and an electrical outlet at the access point.

Wireless access point	BE@.100	Ea	56.00	4.10	60.10
-----------------------	---------	----	-------	------	-------

Remote high gain antenna for a wireless network access point. (Extends the range of wireless connections beyond the usual 50 to 100 feet.) Add the cost of cable connection to the wireless router/access point.

8 Dbi high gain panel antenna	—	Ea	59.50	—	59.50
-------------------------------	---	----	-------	---	-------

Cable for high gain antennae, thin ethernet, 50 ohm, (RG58). Used to connect a high gain antenna to the wireless access points.

PVC cable	BE@.008	LF	.20	.33	.53
Plenum cable	BE@.008	LF	.60	.33	.93

Electrical Work, Digital Networking

	Craft@Hrs	Unit	Material	Labor	Total
Connection of live internet feed to each computer. Includes physical connection of DSL or cable internet feed, internet setup per carriers' instruction, setup and testing of live feed at each outlet and wireless access point. Testing assumes the computers are installed and running.					
Connection and setup of Internet feed	BE@2.00	Ea	—	82.10	82.10
Testing of live feed at each computer	BE@1.00	Ea	—	41.00	41.00
Post installation of room/station computer setup. Assumes a peer to peer network with resources shared per the customers' preference, including browser and email setup.					
Cost per computer configuration	—	LS	—	—	60.10
Digital Networking Systems, Subcontract Modular and expandable electronic gateway for the in-home distribution of external services such as CATV, satellite TV, broadcast TV, telephone and high speed internet access. System also processes and redistributes in-home generated signals such as those from VCRs, DVD players, audio, security cameras and computers. Provides (6) computer local area network (LAN) outlets, (6) telephone jacks and (6) cable hookups where required. Costs include standalone console, 1,000' of each type of cable (phone, network, video), installation and connection.					
Basic networking system					
Six TV and eight voice locations	—	LS	—	—	638.00
Apartment type networking system					
Six video, six data and six voice locations	—	LS	—	—	698.00
Amplified networking system. Video and voice surge protection					
Six video, six data and 15 voice locations	—	LS	—	—	812.00
Large amplified networking system. Video and voice surge protection					
Six video, 8 data and 18 voice locations	—	LS	—	—	905.00
Electrical generators, residential Suitable for standby or extended primary power generation. Dual fuel (liquid propane or natural gas) two-stroke, V-twin cylinder, 60 Hz, single phase, UL and CSA listed. Emissions certified to EPA Tier 3 rating. 65 decibels sound output rating at 10 feet. Control package includes digital engine and generator control panel, ground fault interruption, lightning shield and combination voltage regulator and automatic transfer switch with automatic dual utility connection lockout. Includes fused main circuit breaker, electronic load-sharing module for generator ganging, electric starter motor, battery and trickle charger. Add the cost of connecting electrical loads and electrical controls. Add 4,000 lb. capacity rough-terrain fork lift, if required. Includes set in place only.					
7 KW, 120 volt	B8@1.00	Ea	4,700.00	36.80	4,736.80
10 KW, 120 volt	B8@1.00	Ea	5,740.00	36.80	5,776.80
12 KW, 120 volt	B8@1.00	Ea	9,320.00	36.80	9,356.80
15 KW, 120 volt	B8@1.00	Ea	12,000.00	36.80	12,036.80
20 KW, 120 volt	B8@1.00	Ea	18,500.00	36.80	18,536.80
65 KW, 400/480 volt	B8@1.00	Ea	77,800.00	36.80	77,836.80
100 KW, 400/480 volt	B8@1.00	Ea	120,000.00	36.80	120,036.80
150 KW, 400/480 volt	B8@1.00	Ea	179,000.00	36.80	179,036.80
200 KW, 400/480 volt	B8@1.00	Ea	241,000.00	36.80	241,036.80
250 KW, 400/480 volt	B8@1.00	Ea	299,000.00	36.80	299,036.80
Residential motor generator installation					
Form and pour slab foundation	B5@.069	SF	4.03	2.58	6.61
Tie-down and leveling	B1@1.00	Ea	28.10	34.10	62.20
Piping for twin fuel trains, lube oil cooling, and dedicated fire protection	B9@0.04	LF	3.12	1.33	4.45
Mount and wire automatic transfer switch to household main breaker box	BE@.184	LF	.44	7.55	7.99
Check and test wiring	BE@.250	LF	.37	10.30	10.67
RFI, lightning and ground fault wiring	BE@.184	LF	.40	7.55	7.95
350 gallon propane tank	B9@1.00	Ea	845.00	33.40	878.40
Fire protection CO2 extinguisher and piping	B9@2.00	Ea	226.00	66.70	292.70

Electrical Generators, Residential

	Craft@Hrs	Unit	Material	Labor	Total
Soundproof "doghouse" enclosure for reduction of noise level to 10 decibels at 10 feet distance. Includes vertical support studs, spacers, fasteners and trim. Complies with American Institute of Sound Engineering specifications. Per square foot of wall or ceiling covered.					
Sidewall coverage	D1@.040	SF	2.78	1.48	4.26
Ceiling coverage	D1@.060	SF	2.78	2.22	5.00
Utility shed generator enclosure, 5/8" plywood with 2 x 4 frame, prefabricated kit, weatherized, with mansard roof, double door, lock assembly, and dual galvanized metal screened lintel air inlet and exhaust vents					
Generator enclosure, per SF of floor	D1@.020	SF	13.30	.74	14.04
Combination digital load/voltage controller, usage meter with main breaker box and controls tie-in					
Controller	BE@.184	Ea	1,630.00	7.55	1,637.55
Zone control fused panel box to shield sensitive electronics and home medical electronics for handicapped					
Fused panel box	BE@.184	Ea	676.00	7.55	683.55
Uninterruptible power supply and trickle charger for sensitive electronic and medical appliances					
UPS	BE@.184	Ea	602.00	7.55	609.55
Automatic supervisory control and data acquisition (SCADA) notification circuit to local emergency services to prevent electrical shock of electrical utility repair technicians or fire department personnel					
Notification circuit	BE@.184	Ea	267.00	7.55	274.55
Generator-activated power failure lighting system. Self-diagnostic emergency lighting fixtures, microprocessor based, continuously monitored, with battery and lamps.					
Two-lamp emergency fixture	BE@.825	Ea	184.00	33.80	217.80

Wind turbine generators Vertical dual-use ventilator or conventional horizontal type, rated and certified to California Construction Code and American Wind Energy Association standards. Technospin, Rooftop Wind Power LLC, or equal. Rated wind speed 11 m/s (24.6 mph) start-up wind: 2.5 m/s (5.6 mph) survival wind: 60 m/s (134 mph) max. Permanent magnet generator. Generator voltage for battery charging: 12 to 48 V DC. Voltage for grid connection is adjusted to requirements of inverter. Overspeed protection, mechanical and electrical system. Maximum axis load: 150 Kg force (330 lb). Installation specifications are for rooftop mounting. For tax incentives, see <https://smarterhouse.org/resources/federal-tax-incentives>. Costs include weather-proof metal enclosure, wind rotor, generator, main wiring and breaker, overspeed protection, control modules and basic power meter. Add the cost of design work, regulatory fees and insurance inspection, electrical interconnection to the power grid and battery backup, if required.



Wind turbine electrical generator					
100 watts	R1@2.50	Ea	471.00	90.60	561.60
500 watts	R1@3.00	Ea	2,040.00	109.00	2,149.00
750 watts	R1@3.00	Ea	3,540.00	109.00	3,649.00
1.0 Kw	R1@3.50	Ea	4,710.00	127.00	4,837.00
1.5 Kw	R1@3.50	Ea	7,070.00	127.00	7,197.00
2.0 Kw	R1@4.00	Ea	9,440.00	145.00	9,585.00
Base plate for rooftop mount	BE@1.00	Ea	184.00	41.00	225.00
Tie-down for generator	R1@.250	Ea	334.00	9.06	343.06
Electric and control modules	BE@.350	Ea	29.90	14.40	44.30
Install electrical wiring (typical)	BE@.150	LF	2.23	6.15	8.38
Install controls	BE@.500	Ea	—	20.50	20.50
Commission and test	BE@4.00	Ea	—	164.00	164.00

Elevators and Lifts, Subcontract

Craft@Hrs Unit Material Labor Total

Elevators and Lifts, Subcontract Elevators for apartments or commercial buildings, hydraulic vertical cab, meets code requirements for public buildings, 2,500 pound capacity, to 13 passengers. Includes side opening sliding door, illuminated controls, emergency light, alarm, code-approved fire service operation, motor control unit, wiring in hoistway, cab and door design options.



Basic 2 stop, typical costs

100 feet per minute	—	LS	—	—	47,800.00
125 feet per minute	—	LS	—	—	52,300.00
150 feet per minute	—	LS	—	—	56,300.00
Add per stop to 5 stops	—	LS	—	—	5,150.00
Add for infrared door protection	—	Ea	—	—	1,930.00
Add for hall position indicator	—	Ea	—	—	474.00
Add for car position indicator	—	Ea	—	—	474.00
Add for car direction light & tone	—	Ea	—	—	474.00
Add for hall lantern with audible tone	—	Ea	—	—	474.00

Elevators for private residences, electric cable, motor driven, 500 pound capacity, includes complete installation of elevator, controls and safety equipment. Meets code requirements for residences

2 stops (up to 10' rise)	—	LS	—	—	24,900.00
3 stops (up to 20' rise)	—	LS	—	—	28,200.00
4 stops (up to 30' rise)	—	LS	—	—	31,700.00
5 stops (up to 40' rise)	—	LS	—	—	35,000.00
Add for additional gate	—	Ea	—	—	1,090.00

Dumbwaiters, electric

75 pound, 2 stop, 24" x 24" x 30"	—	LS	—	—	9,650.00
75 pound, add for each extra stop	—	Ea	—	—	1,740.00
100 pound, 2 stop, 24" x 30" x 36"	—	LS	—	—	10,800.00
100 pound, add for each extra stop	—	Ea	—	—	1,950.00
100 pound, 2 stop, 24" x 24" x 36", tray type	—	LS	—	—	14,900.00
100 pound tray type, add for each extra stop	—	Ea	—	—	2,330.00
300 pound, 2 stop, 30" x 30" x 36", tray type	—	LS	—	—	21,900.00
300 pound, add for each extra stop	—	Ea	—	—	3,460.00
500 pound, 2 stop, 23" x 56" x 48"	—	LS	—	—	23,300.00
500 pound, add for each extra stop	—	Ea	—	—	3,460.00

Hydraulic elevators, private residence, 750 pound capacity. Includes controls and safety equipment with standard unfinished birch plywood cab and one gate.

2 stops (up to 15' rise)	—	LS	—	—	26,900.00
3 stops (up to 22' rise)	—	LS	—	—	30,700.00
4 stops (up to 28' rise)	—	LS	—	—	33,800.00
5 stops (up to 34' rise)	—	LS	—	—	39,800.00
Add for adjacent opening	—	Ea	—	—	636.00
Add for additional gate	—	Ea	—	—	1,100.00
Add for plastic laminate cab	—	Ea	—	—	48.10
Add for oak raised panel cab	—	Ea	—	—	3,700.00



Stairlifts (incline lifts), single passenger, indoor. Lift to 18' measured diagonally. 300 pound capacity. Includes top and bottom call button, safety chair, track, power unit, installation by a licensed elevator contractor. Single family residential use

Straight stairs	—	LS	—	—	4,400.00
-----------------	---	----	---	---	----------

Wheelchair lift (porch lift), screw driven, fully enclosed sides.

Typical electrical connections and control included. Up to 5' rise

Residential wheelchair lift	—	LS	—	—	9,930.00
-----------------------------	---	----	---	---	----------



Engineering Fees

	Craft@Hrs	Unit	Material	Labor	Total
Engineering Fees Typical cost for consulting work.					
Acoustical engineering (Based on an hourly wage of \$70.00 to \$135.00)					
Environmental noise survey of a lot; includes technician with measuring equipment, data reduction and analysis, and written report with recommendations					
Written report with recommendations	—	LS	—	—	2,050.00
Exterior to interior noise analysis	—	LS	—	—	675.00
Measure "Impact Insulation Class" and "Sound Transmission Class" in existing buildings, (walls, floors, and ceilings)					
Minimum cost	—	LS	—	—	1,340.00
Priced by wall, floor, or ceiling sections					
Per section, approx. 100 SF	—	Ea	—	—	674.00
Analyze office, conference room, or examining room to assure acoustical privacy					
Per room analyzed	—	LS	—	—	592.00
Prepare acoustical design for church, auditorium, or lecture hall, (fees vary greatly with complexity of acoustics desired)					
Typical cost	—	LS	—	—	2,510.00
Evaluate noise problems from proposed building					
Impact on surrounding environment	—	LS	—	—	1,340.00
Evaluate noise problems from surrounding environment					
Impact on a proposed building	—	LS	—	—	1,100.00
Front end scheduling. Coordinate architectural, engineering and other consultant services, plan check times and other approval times					
For residential and commercial projects	—	LS	—	—	7,840.00
Project scheduling using CPM (Critical Path Method). Includes consultation, review of construction documents, development of construction logic, and graphic schedule. Comprehensive schedules to meet government or owner specifications will cost more.					
Wood frame buildings, 1 or 2 stories	—	LS	—	—	5,240.00
Structural engineering plan check, typical 2-story, 8 to 10 unit apartment building					
Typical price per apartment building	—	LS	—	—	1,380.00
Add for underground parking	—	LS	—	—	1,120.00

Entrances, Colonial An entrance consists of two pilasters (one at each side of the exterior opening) and a crosshead at the top of the door. A decorative pediment may rest on the crosshead. No crosshead is required if the pediment includes a breastboard. No door, frame or sill costs are included in the estimates below. Unpainted urethane.

Molded one-piece pilasters with plinth blocks, per set of two pilasters					
1-1/2" wide x 86" high	BC@.800	Ea	52.60	30.10	82.70
3-1/2" wide x 81" high	BC@.800	Ea	66.10	30.10	96.20
3-1/2" wide x 108" high	BC@.800	Ea	81.40	30.10	111.50
5" wide x 108" high	BC@.800	Ea	122.00	30.10	152.10
7" wide x 90" high	BC@.800	Ea	147.00	30.10	177.10
9" wide x 90" high	BC@.800	Ea	189.00	30.10	219.10
9" wide x 108" high	BC@.800	Ea	190.00	30.10	220.10
11" wide x 144" high	BC@.800	Ea	341.00	30.10	371.10
Molded entrance crosshead, without pediment					
40" wide by 6" high	BC@.400	Ea	54.10	15.10	69.20
48" wide by 6" high	BC@.400	Ea	64.90	15.10	80.00
78" wide by 6" high	BC@.400	Ea	106.00	15.10	121.10
40" wide by 10" high	BC@.400	Ea	92.10	15.10	107.20
48" wide by 10" high	BC@.400	Ea	109.00	15.10	124.10
78" wide by 10" high	BC@.400	Ea	172.00	15.10	187.10

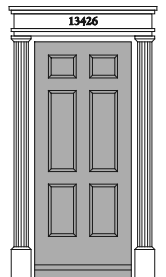

Excavation

	Craft@Hrs	Unit	Material	Labor	Total
40" wide by 14" high	BC@.400	Ea	161.00	15.10	176.10
48" wide by 14" high	BC@.400	Ea	198.00	15.10	213.10
78" wide by 14" high	BC@.400	Ea	241.00	15.10	256.10
96" wide by 14" high	BC@.400	Ea	305.00	15.10	320.10
Molded pediment without breastboard (crosshead required)					
38" wide, 10" high peaked cap	BC@.400	Ea	115.00	15.10	130.10
48" wide, 13" high peaked cap	BC@.400	Ea	210.00	15.10	225.10
78" wide, 21" high peaked cap	BC@.400	Ea	221.00	15.10	236.10
42" wide, 12" high decorative acorn	BC@.400	Ea	109.00	15.10	124.10
56" wide, 13" high decorative acorn	BC@.400	Ea	97.90	15.10	113.00
78" wide, 16" high decorative acorn	BC@.400	Ea	206.00	15.10	221.10
49" wide, 18" high ram's head	BC@.400	Ea	190.00	15.10	205.10
61" wide, 21" high ram's head	BC@.400	Ea	177.00	15.10	192.10
91" wide, 29" high ram's head	BC@.400	Ea	261.00	15.10	276.10
Molded pediment with breastboard (no crosshead required)					
40" wide, 17" high peaked cap	BC@.400	Ea	115.00	15.10	130.10
48" wide, 19" high peaked cap	BC@.400	Ea	141.00	15.10	156.10
80" wide, 29" high peaked cap	BC@.400	Ea	226.00	15.10	241.10
50" wide, 21" high decorative acorn	BC@.400	Ea	119.00	15.10	134.10
58" wide, 22" high decorative acorn	BC@.400	Ea	163.00	15.10	178.10
80" wide, 26" high decorative acorn	BC@.400	Ea	217.00	15.10	232.10
50" wide, 24" high ram's head	BC@.400	Ea	190.00	15.10	205.10
58" wide, 25" high ram's head	BC@.400	Ea	235.00	15.10	250.10
80" wide, 36" high ram's head	BC@.400	Ea	310.00	15.10	325.10

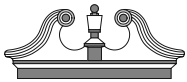

Excavation and Backfill by Hand Using hand tools.

General excavation, using a pick and shovel (loosening and one throw)

Light soil	BL@1.10	CY	—	33.60	33.60
Average soil	BL@1.70	CY	—	51.90	51.90
Heavy soil or loose rock	BL@2.25	CY	—	68.70	68.70
Backfilling (one shovel throw from stockpile)					
Sand	BL@.367	CY	—	11.20	11.20
Average soil	BL@.467	CY	—	14.30	14.30
Rock or clay	BL@.625	CY	—	19.10	19.10
Add for compaction, average soil or sand	BL@.400	CY	—	12.20	12.20
Fine grading	BL@.008	SF	—	.24	.24
Footings, light soil, using a pick and shovel					
6" deep x 12" wide (1.85 CY per CLF)	BL@.034	LF	—	1.04	1.04
8" deep x 12" wide (2.47 CY per CLF)	BL@.050	LF	—	1.53	1.53
8" deep x 16" wide (3.29 CY per CLF)	BL@.055	LF	—	1.68	1.68
8" deep x 18" wide (3.70 CY per CLF)	BL@.060	LF	—	1.83	1.83
10" deep x 12" wide (3.09 CY per CLF)	BL@.050	LF	—	1.53	1.53
10" deep x 16" wide (4.12 CY per CLF)	BL@.067	LF	—	2.05	2.05
10" deep x 18" wide (4.63 CY per CLF)	BL@.075	LF	—	2.29	2.29
12" deep x 12" wide (3.70 CY per CLF)	BL@.060	LF	—	1.83	1.83
12" deep x 16" wide (4.94 CY per CLF)	BL@.081	LF	—	2.47	2.47
12" deep x 20" wide (6.17 CY per CLF)	BL@.100	LF	—	3.06	3.06
12" deep x 24" wide (7.41 CY per CLF)	BL@.125	LF	—	3.82	3.82
16" deep x 16" wide (6.59 CY per CLF)	BL@.110	LF	—	3.36	3.36
Add for average soil - loose rock or roots	—	%	—	50.0	—
Loading trucks (shoveling, one throw)					
Average soil	BL@1.45	CY	—	44.30	44.30
Rock or clay	BL@2.68	CY	—	81.90	81.90

Excavation

	Craft@Hrs	Unit	Material	Labor	Total
Pits to 5' (pits over 5' require shoring)					
Light soil	BL@1.34	CY	—	40.90	40.90
Average soil	BL@2.00	CY	—	61.10	61.10
Heavy soil	BL@2.75	CY	—	84.00	84.00
Shaping trench bottom for pipe					
To 10" pipe	BL@.024	LF	—	.73	.73
12" to 20" pipe	BL@.076	LF	—	2.32	2.32
Shaping embankment slopes					
Up to 1 in 4 slope	BL@.060	SY	—	1.83	1.83
Over 1 in 4 slope	BL@.075	SY	—	2.29	2.29
Add for top crown or toe	—	%	—	50.0	—
Add for swales	—	%	—	90.0	—
Spreading material piled on site					
Average soil	BL@.367	CY	—	11.20	11.20
Stone or clay	BL@.468	CY	—	14.30	14.30
Strip and pile top soil, depths to 6"	BL@.024	SF	—	.73	.73
Tamping, hand tamp only	BL@.612	CY	—	18.70	18.70
Trenches to 5', soil piled beside trench					
Light soil	BL@1.13	CY	—	34.50	34.50
Average soil	BL@1.84	CY	—	56.20	56.20
Heavy soil or loose rock	BL@2.86	CY	—	87.40	87.40

Craft@Hrs Unit Material Labor Equipment Total

Trenching and Backfill with Heavy Equipment These costs and productivity are based on utility line trenches and continuous footings where the spoil is piled adjacent to the trench. Linear feet (LF) and cubic yards (CY) per hour shown are based on a crew of two. Reduce productivity by 10% to 25% when spoil is loaded in trucks. Shoring, dewatering or unusual conditions are not included.

Wheel loader 55 HP, with integral backhoe

12" wide bucket, for 12" wide trench. Depths 3' to 5'

Light soil (60 LF per hour)	B8@.033	LF	—	1.22	.75	1.97
Medium soil (55 LF per hour)	B8@.036	LF	—	1.33	.81	2.14
Heavy or wet soil (35 LF per hour)	B8@.057	LF	—	2.10	1.29	3.39

18" wide bucket, for 18" wide trench. Depths 3' to 5'

Light soil (55 LF per hour)	B8@.036	LF	—	1.33	.81	2.14
Medium soil (50 LF per hour)	B8@.040	LF	—	1.47	.90	2.37
Heavy or wet soil (30 LF per hour)	B8@.067	LF	—	2.47	1.51	3.98

24" wide bucket, for 24" wide trench. Depths 3' to 5'

Light soil (50 LF per hour)	B8@.040	LF	—	1.47	.90	2.37
Medium soil (45 LF per hour)	B8@.044	LF	—	1.62	.99	2.61
Heavy or wet soil (25 LF per hour)	B8@.080	LF	—	2.95	1.81	4.76

Backfill trenches from loose material piled adjacent to trench. No compaction included.

Soil, previously excavated

Front-end loader 60 HP

(50 CY per hour)	B8@.040	CY	—	1.47	.81	2.28
------------------	---------	----	---	------	-----	------

D-3 crawler dozer

(25 CY per hour)	B8@.080	CY	—	2.95	2.22	5.17
------------------	---------	----	---	------	------	------

3/4 CY crawler loader

(33 CY per hour)	B8@.061	CY	—	2.25	1.37	3.62
------------------	---------	----	---	------	------	------

D-7 crawler dozer

(130 CY per hour)	B8@.015	CY	—	.55	.92	1.47
-------------------	---------	----	---	-----	-----	------

Sand or gravel bedding

3/4 CY wheel loader

(80 CY per hour)	B8@.025	CY	—	.92	.41	1.33
------------------	---------	----	---	-----	-----	------

Excavation with Heavy Equipment

	Craft@Hrs	Unit	Material	Labor	Equipment	Total
Compaction of soil in trenches in 8" layers						
Pneumatic tampers (40 CY per hour)	BL@.050	CY	—	1.53	1.38	2.91
Vibrating rammers, gasoline powered "Jumping Jack" (20 CY per hour)	BL@.100	CY	—	3.06	1.20	4.26
	Craft@Hrs	Unit	Material	Labor	Equipment	Total
Excavation with Heavy Equipment These figures assume a crew of one operator unless noted otherwise. Only labor costs are included here. See equipment rental costs at the end of this section. Use the productivity rates listed here to determine the number of hours or days that the equipment will be needed. For larger jobs and commercial work, see excavation costs under Site Work in the Commercial and Industrial division of this book.						
Excavation rule of thumb for small jobs	—	CY	—	2.85	2.85	2.85
Backhoe, operator and one laborer, 3/4 CY bucket						
Light soil (13.2 CY per hour)	B8@.152	CY	—	5.60	5.60	5.60
Average soil (12.5 CY per hour)	B8@.160	CY	—	5.89	5.89	5.89
Heavy soil (10.3 CY per hour)	B8@.194	CY	—	7.14	7.14	7.14
Sand (16 CY per hour)	B8@.125	CY	—	4.60	4.60	4.60
Add when using 1/2 CY bucket	—	%	—	25.0	—	—
Bulldozer, 65 HP unit						
Backfill (36 CY per hour)	0E@.027	CY	—	1.16	1.16	1.16
Clearing brush (900 SF per hour)	0E@.001	SF	—	.04	.04	.04
Add for thick brush	—	%	—	300.0	—	—
Spread dumped soil (42 CY per hour)	0E@.024	CY	—	1.03	1.03	1.03
Strip topsoil (17 CY per hour)	0E@.059	CY	—	2.54	2.54	2.54
Bulldozer, 90 HP unit						
Backfill (40 CY per hour)	0E@.025	CY	—	1.08	1.08	1.08
Clearing brush (1,000 SF per hour)	0E@.001	SF	—	.04	.04	.04
Add for thick brush	—	%	—	300.0	—	—
Spread dumped soil (45 CY per hour)	0E@.023	CY	—	.99	.99	.99
Strip top soil (20 CY per hour)	0E@.050	CY	—	2.15	2.15	2.15
Bulldozer, 140 HP unit						
Backfill (53 CY per hour)	0E@.019	CY	—	.82	.82	.82
Clearing brush (1,250 SF per hour)	0E@.001	SF	—	.04	.04	.04
Add for thick brush	—	%	—	200.0	—	—
Spread dumped soil (63 CY per hour)	0E@.016	CY	—	.69	.69	.69
Strip top soil (25 CY per hour)	0E@.040	CY	—	1.72	1.72	1.72
Dump truck, spot, load, unload, travel						
3 CY truck						
Short haul (9 CY per hour)	B7@.222	CY	—	6.92	6.92	6.92
2-3 mile haul (6 CY per hour)	B7@.333	CY	—	10.40	10.40	10.40
4 mile haul (4 CY per hour)	B7@.500	CY	—	15.60	15.60	15.60
5 mile haul (3 CY per hour)	B7@.666	CY	—	20.70	20.70	20.70
4 CY truck						
Short haul (11 CY per hour)	B7@.182	CY	—	5.67	5.67	5.67
2-3 mile haul (7 CY per hour)	B7@.286	CY	—	8.91	8.91	8.91
4 mile haul (5.5 CY per hour)	B7@.364	CY	—	11.30	11.30	11.30
5 mile haul (4.5 CY per hour)	B7@.444	CY	—	13.80	13.80	13.80
5 CY truck						
Short haul (14 CY per hour)	B7@.143	CY	—	4.45	4.45	4.45
2-3 mile haul (9.5 CY per hour)	B7@.211	CY	—	6.57	6.57	6.57
4 mile haul (6.5 CY per hour)	B7@.308	CY	—	9.59	9.59	9.59
5 mile haul (5.5 CY per hour)	B7@.364	CY	—	11.30	11.30	11.30

Excavation Equipment Rental

	Craft@Hrs	Unit	Material	Labor	Total
Jackhammer, one laborer (per CY of unloosened soil)					
Average soil (2-1/2 CY per hour)	BL@.400	CY	—	12.20	12.20
Heavy soil (2 CY per hour)	BL@.500	CY	—	15.30	15.30
Igneous or dense rock (.7 CY per hour)	BL@1.43	CY	—	43.70	43.70
Most weathered rock (1.2 CY per hour)	BL@.833	CY	—	25.40	25.40
Soft sedimentary rock (2 CY per hour)	BL@.500	CY	—	15.30	15.30
Air tamp (3 CY per hour)	BL@.333	CY	—	10.20	10.20
Loader (tractor shovel)					
Piling earth on premises, 1 CY bucket					
Light soil (43 CY per hour)	OE@.023	CY	—	.99	.99
Heavy soil (35 CY per hour)	OE@.029	CY	—	1.25	1.25
Loading trucks, 1 CY bucket					
Light soil (53 CY per hour)	OE@.019	CY	—	.82	.82
Average soil (43 CY per hour)	OE@.023	CY	—	.99	.99
Heavy soil (40 CY per hour)	OE@.025	CY	—	1.08	1.08
Deduct for 2-1/4 CY bucket	—	%	—	-43.0	—
Sheepsfoot roller (18.8 CSF per hour)	OE@.001	SF	—	.04	.04
Sprinkling with truck, (62.3 CSF per hour)	TR@.001	SF	—	.03	.03
Tree and brush removal, labor only (clear and grub, one operator and one laborer)					
Light brush	B8@34.8	Acre	—	1,280.00	1,280.00
Heavy brush	B8@45.2	Acre	—	1,660.00	1,660.00
Wooded	B8@48.7	Acre	—	1,790.00	1,790.00
Tree removal, cutting trees, removing branches, cutting into short lengths with chain saws and axes, by tree diameter, labor only					
8" to 12" (5 manhours per tree)	BL@5.00	Ea	—	153.00	153.00
13" to 18" (7 manhours per tree)	BL@7.00	Ea	—	214.00	214.00
19" to 24" (11 manhours per tree)	BL@11.0	Ea	—	336.00	336.00
25" to 36" (14 manhours per tree)	BL@14.0	Ea	—	428.00	428.00
Tree stump removal, using a small backhoe, by tree diameter, operator only					
6" to 10" (1.6 manhours per stump)	OE@1.60	Ea	—	68.90	68.90
11" to 14" (2.1 manhours per stump)	OE@2.10	Ea	—	90.50	90.50
15" to 18" (2.6 manhours per stump)	OE@2.60	Ea	—	112.00	112.00
19" to 24" (3.1 manhours per stump)	OE@3.10	Ea	—	134.00	134.00
25" to 30" (3.3 manhours per stump)	OE@3.30	Ea	—	142.00	142.00
Trenching machine, crawler-mounted					
Light soil (27 CY per hour)	OE@.037	CY	—	1.59	1.59
Heavy soil (21 CY per hour)	OE@.048	CY	—	2.07	2.07
Add for pneumatic-tired machine	—	%	—	15.0	—

Excavation Equipment Rental Costs Typical cost not including fuel, delivery or pickup charges. Add labor costs from the previous section. Half day minimums.

	1/2 day	Day	Week
Backhoe, wheeled mounted			
55 HP unit, 1/8 to 3/4 CY bucket	294.00	420.00	1,160.00
65 HP unit, 1/4 to 1 CY bucket	344.00	492.00	1,600.00
Add for each delivery or pickup	175.00	175.00	175.00
Bulldozer, crawler tractor			
65 HP	357.00	510.00	1,530.00
90 to 105 HP unit, D-4 or D-5	472.00	674.00	1,820.00
140 HP unit, D-6	645.00	921.00	2,630.00
Add for each delivery or pickup	175.00	175.00	175.00

Excavation Equipment Rental

	1/2 day	Day	Week
Dump truck, on-highway type			
3 CY	301.00	430.00	1,130.00
5 CY	319.00	455.00	1,200.00
10 CY	671.00	959.00	3,030.00
Wheel loaders, front-end load and dump, diesel			
3/4 CY bucket, 4WD, articulated	139.00	199.00	698.00
1 CY bucket, 4WD, articulated	283.00	404.00	1,070.00
2 CY bucket, 4WD, articulated	389.00	556.00	1,680.00
3-1/4 CY bucket, 4WD, articulated	613.00	875.00	2,520.00
5 CY bucket, 4WD, articulated	721.00	1,030.00	3,100.00
Add for each delivery or pickup	175.00	175.00	175.00
Sheepsfoot roller, towed type, 40" diameter, 48" wide, double drum	151.00	216.00	657.00
Trenching machine, to 5'6" depth, 6" to 16" width capacity, crawler-mounted type	169.00	242.00	778.00
Add for each delivery or pickup	175.00	175.00	175.00
Compactor, 32" plate width, manually guided, gasoline engine, vibratory plate type	244.00	349.00	878.00
Chain saw, 18" to 23" bar, gasoline engine	112.00	160.00	387.00
Breakers, pavement, medium duty, with blade Including 50' of 1" hose	69.00	99.00	282.00
Air compressors, trailer-mounted, gas powered, silenced			
100 CFM to 150 CFM	146.00	208.00	537.00
175 CFM	256.00	365.00	937.00

	Craft@Hrs	Unit	Material	Labor	Total
--	-----------	------	----------	-------	-------

Fans

Economy ceiling and wall exhaust fan. For baths, utility, and recreation rooms. For baths up to 45 square feet, other rooms up to 60 square feet. Installs in ceiling or in wall. Plastic duct collar. White polymeric grille. UL listed for use in tub and shower enclosure with GFI branch circuit wiring. Housing dimensions: 8-1/16-inch length, 7-3/16-inch width, 3-7/8-inch depth. Grille size, 8-11/16-inch x 9-1/2-inch. 3-inch duct. 0.75 amp. CFM (cubic feet of air per minute). Labor includes setting and connecting only. Add the cost of wiring and ducting.

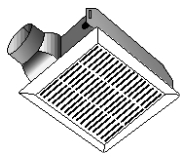

50 CFM, 2.5 sones	BE@1.00	Ea	14.80	41.00	55.80
70 CFM, 4.0 sones	BE@1.00	Ea	35.30	41.00	76.30

Vertical discharge bath fan. Galvanized steel housing, with built-in damper and spin-on white polymeric grille. Polymeric fan blade and duct connectors. Built-in double steel mounting ears with keyhole slots. Fits 8-inch ducts. UL listed. CFM (cubic feet of air per minute). Labor includes setting and connecting only. Add the cost of wiring and ducting.



80 CFM, 1.0 sones	BE@1.00	Ea	98.90	41.00	139.90
-------------------	---------	----	-------	-------	--------

Vertical discharge utility fan. Mounts in ceiling. Discharges through duct to roof or wall. Pre-wired motor with plug-in receptacle. Adjustable hanger bars for 16- or 24-inch on-center joists. Silver anodized aluminum grille. Fits 7-inch round ducts. Housing dimensions: 11-inch diameter x 5-5/8-inch deep. UL listed. CFM (cubic feet of air per minute). Labor includes setting and connecting only. Add the cost of wiring and ducting.

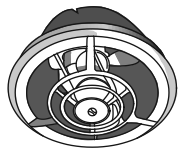

210 CFM, 6.5 sones	BE@1.00	Ea	67.70	41.00	108.70
--------------------	---------	----	-------	-------	--------

Ceiling or wall bath exhaust fan. White polymeric grille. Torsion spring grille mounting requires no tools. Plug-in, permanently lubricated motor. Centrifugal blower wheel. Rugged, 26 gauge galvanized steel housing. Sturdy key holes mounting brackets for quick, accurate installation. Tapered, polymeric duct fitting with built-in backdraft damper. U.L. listed for use over bathtubs and showers when connected to a GFCI circuit. 120 volts, 0.5 amps, 2.5 sones, 80 CFM (HVI-2100 certified) and 4-inch round duct. Labor includes setting and connecting only. Add the cost of wiring and ducting.

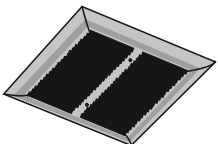

80 CFM, 2.5 sones	BE@1.00	Ea	71.70	41.00	112.70
-------------------	---------	----	-------	-------	--------

Fans

Craft@Hrs Unit Material Labor Total

Bath exhaust fan. Pre-wired outlet box for plug-in receptacle, torsion spring-mounted low-profile grille. Steel housing, damper to eliminate back drafts. Labor includes setting and connecting only. Add the cost of wiring and ducting.

80 CFM, 2.5 sones, to 80 SF bath BE@1.00 Ea 99.50 41.00 140.50

Thru-the-wall utility fan. Steel housing with built-in damper and white polymeric grille. Permanently lubricated motor. Rotary on and off switch. Housing dimensions: 14-1/4-inch length, 14-1/4-inch width, 4-1/2-inch depth. UL listed. CFM (cubic feet of air per minute). Labor includes setting and connecting only. Add the cost of wiring and exterior finish.

180 CFM, 5.0 sones BE@1.00 Ea 67.60 41.00 108.60

QuietTest® low-sound bath fan. For 105 square foot bath. Pre-wired outlet box with plug-in receptacle. Adjustable hanger brackets. Fits 4-inch round ducts. Low-profile white polymeric grille, torsion-spring mounted. Housing dimensions: 9-3/8-inch length, 11-1/4-inch width, 7-7/8-inch depth. Grille size, 14-1/4-inch x 12-1/16-inch. UL listed for use in tub and shower when used with GFI branch circuit wiring. Not recommended for kitchen use. CFM (cubic feet of air per minute). Labor includes setting and connecting only. Add the cost of wiring and ducting.

110 CFM, 2.0 sones BE@1.00 Ea 126.00 41.00 167.00

QuietTest® low-sound ceiling blower. For 375 square foot room. Pre-wired outlet box with plug-in receptacle. Rounded, low-profile white polymeric grille with silver anodized trim at each end. Fits 3-1/4-inch x 10-inch ducts. Housing dimensions: 14-1/4-inch length, 10-inch width, 9-inch depth. Grille size, 16-1/2-inch x 12-3/32 inch. CFM (cubic feet of air per minute). Labor includes setting and connecting only. Add the cost of wiring and ducting.

300 CFM, 4.5 sones BE@1.00 Ea 153.00 41.00 194.00

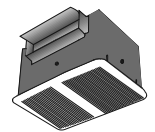
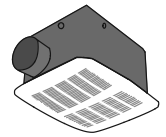
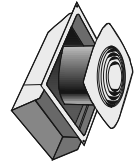

Lighted Bath Exhaust Fans

ValueTest™ economy bath fan and light, NuTone. Fan and light operate separately or together. Fits 4-inch ducts. White polymeric grille with break-resistant lens. Uses 100-watt lamp (not included). Housing dimensions: 9-inch length, 9-inch width, 5-1/2-inch depth. Grille size, 10-3/4-inch x 12-1/8-inch. UL listed for use in tub and shower when used with GFI branch circuit wiring. CFM (cubic feet of air per minute). Labor includes setting and connecting only. Add the cost of wiring and ducting.

50 CFM, 2.5 sones, 45 SF bath BE@1.00 Ea 34.80 41.00 75.80

70 CFM, 4.5 sones, 65 SF bath BE@1.00 Ea 75.70 41.00 116.70

Decorative bath exhaust fan with light, Broan Manufacturing. Corrosion-resistant finish. Frosted melon glass globe. 60 watt max. CFM (cubic feet of air per minute). Labor includes setting and connecting only. Add the cost of wiring and ducting.

70 CFM, 3.5 sones BE@1.00 Ea 78.20 41.00 119.20

Exhaust Air deluxe bath fan with light, NuTone. Ventilation for baths up to 95 square feet, other rooms up to 125 square feet. 100 and 7 watt ceiling and night-light or energy-saving fluorescent light (lamps not included). Snap-on grille assembly. Housing dimensions: 9-inch length, 9-inch width, 6-inch depth. Polymeric white grille, 15-inch diameter. UL listed for use in tub and shower when used with GFI branch circuit wiring. CFM (cubic feet of air per minute). Labor includes setting and connecting only. Add the cost of wiring and ducting.

100 CFM, 3.5 sones BE@1.00 Ea 97.60 41.00 138.60

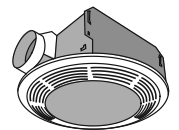
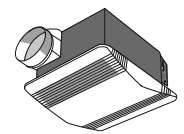

Bath Exhaust Fan with Heater

Infrared bulb heater and fan. 4-point adjustable mounting brackets span up to 24-inches. Uses 250 watt, 120 volt R-40 infrared bulbs (not included). Heater and fan units include 70 CFM, 3.5 sones ventilator fan. Damper and duct connector included. Plastic matte-white molded grille and compact housings. CFM (cubic feet of air per minute). Labor includes setting and connecting only. Add the cost of wiring and ducting.

1-bulb, 70 CFM, 3.5 sones BE@1.00 Ea 65.30 41.00 106.30

2-bulb heater, 7" duct BE@1.10 Ea 79.80 45.10 124.90

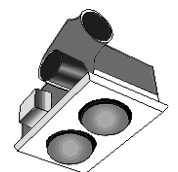

Craft@Hrs Unit Material Labor Total

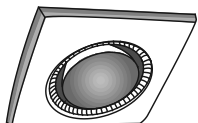

Heat-A-Lamp® bulb heater and fan, NuTone. Non-IC. Swivel-mount. Torsion spring holds plates firmly to ceiling. 250-watt radiant heat from one R-40 infrared heat lamp. Uses 4-inch duct. Adjustable socket for ceilings up to 1-inch thick. Adjustable hanger bars. Automatic reset for thermal protection. White polymeric finish. UL listed. Btu (British Thermal Unit). 6-7/8" high. Labor includes setting and connecting only. Add the cost of wiring and ducting.

2.6 amp, 1 lamp, 12-1/2" x 10"	BE@1.50	Ea	58.30	61.50	119.80
5.0 amp, 2 lamp, 15-3/8" x 11"	BE@1.50	Ea	87.50	61.50	149.00

Surface-mount ceiling bath resistance heater and fan. 1250 watt. 4266 Btu (British Thermal Unit). 120 volt. Chrome alloy wire element for instant heat. Built-in fan. Automatic overheat protection. Low-profile housing. Permanently lubricated motor. Mounts to standard 3-1/4-inch round or 4-inch octagonal ceiling electrical box. Satin-finish aluminum grille extends 2-3/4-inch from ceiling. 11" diameter x 2-3/4" deep. Labor includes setting and connecting only. Add the cost of wiring and ducting.

10.7 amp	BE@.750	Ea	68.60	30.80	99.40
----------	---------	----	-------	-------	-------

Designer Series bath heater and exhaust fan, Broan Manufacturing. 1500-watt fan-forced heater. 120-watt light capacity, 7-watt night-light (bulbs not included). Permanently lubricated motor. Polymeric damper prevents cold back drafts. 4-point adjustable mounting brackets with keyhole slots. Torsion-spring grille mounting, no tools needed. Non-glare light diffusing glass lenses. Fits single gang opening. Suitable for use with insulation. Includes 4-function control unit. CFM (cubic feet of air per minute). 100 CFM, 1.2 sones. Labor includes setting and connecting only. Add the cost of wiring and ducting.

4" duct, 100 watt lamp	BE@1.00	Ea	273.00	41.00	314.00
------------------------	---------	----	--------	-------	--------

Exhaust Fan Accessories

Timer switch

60-minute timer, analog	BE@.250	Ea	24.90	10.30	35.20
60-minute timer, digital	BE@.250	Ea	21.60	10.30	31.90

Exhaust fan switch

On/Off switch with humidity control, white	BE@.300	Ea	30.60	12.30	42.90
--	---------	----	-------	-------	-------

SensAire® 4-function wall control switch. Fits single gang opening. Top switch for on-auto-off. Other switches for light and night-light. For use with SensAire® fans and lights.

White	BE@.250	Ea	23.40	10.30	33.70
-------	---------	----	-------	-------	-------

Bath vent kit, thru-wall, UL listed, 5' of 4" duct, polymeric louvered wall cap, 3" to 4" increaser and 2 clamps. Fire resistant.

Flexible duct	SW@.650	Ea	19.60	27.60	47.20
---------------	---------	----	-------	-------	-------

Roof vent kit. For venting kitchen or bath exhaust fan through slanted roof. Works with both 3-inch and 4-inch ducted units.

8-foot length	SW@.650	Ea	26.10	27.60	53.70
---------------	---------	----	-------	-------	-------

Ventilators

Roof turbine vent with base



12", galvanized	SW@1.00	Ea	28.20	42.50	70.70
12", weathered wood	SW@1.00	Ea	66.90	42.50	109.40
12", white aluminum	SW@1.00	Ea	66.90	42.50	109.40
Add for steep pitch base	SW@.440	Ea	10.30	18.70	29.00
Add for weather cap	—	Ea	12.00	—	12.00

Belt drive attic exhaust fan, 1/3 HP, with aluminum shutter and plenum boards

24" diameter	SW@3.00	Ea	246.00	128.00	374.00
30" diameter	SW@3.00	Ea	338.00	128.00	466.00
36" diameter	SW@3.00	Ea	343.00	128.00	471.00
Add for wifi controls	—	Ea	220.00	—	220.00
Deduct for direct drive exhaust fans	—	%	-15.0	—	—
12-hour timer switch	BE@.950	Ea	42.70	39.00	81.70

Fans

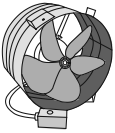
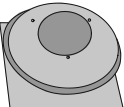
	Craft@Hrs	Unit	Material	Labor	Total	
Power attic gable vent						
1,280 CFM	SW@1.65	Ea	72.20	70.20	142.40	
1,540 CFM	SW@1.65	Ea	90.90	70.20	161.10	
1,600 CFM	SW@1.65	Ea	101.00	70.20	171.20	
Shutter for gable vent	SW@.450	Ea	42.00	19.10	61.10	
Humidistat control	BE@.550	Ea	30.10	22.60	52.70	
Thermostat control	BE@.550	Ea	26.30	22.60	48.90	
Roof-mount power ventilator						
1,250 CFM	SW@1.65	Ea	92.40	70.20	162.60	
1,600 CFM	SW@1.65	Ea	149.00	70.20	219.20	

Ceiling Fans

Ceiling fans, decorative, 3-speed reversible motors, lighting kits optional (see below). Includes 10' of type NM cable, installation and connection.

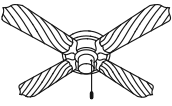
42" four-blade fan, white finish	BE@1.50	Ea	87.10	61.50	148.60	
44" five blade fan with 3 spotlights	BE@1.50	Ea	95.20	61.50	156.70	
44" five-blade reversible fan	BE@1.50	Ea	117.00	61.50	178.50	
48" five rattan blade fan	BE@1.50	Ea	173.00	61.50	234.50	
56" five-blade leaf design premium fan	BE@1.50	Ea	269.00	61.50	330.50	
Optional lighting fixtures for ceiling fans						
Vaulted ceiling mount	BE@.350	Ea	22.10	14.40	36.50	
Schoolhouse or round globe, brass trim	BE@.283	Ea	19.90	11.60	31.50	
Add for ball pull chain	BE@.017	Ea	5.69	.70	6.39	
Add for pack of four ceiling fan light bulbs	BE@.017	Pack	10.00	.70	10.70	

Garage exhaust fans For enclosed automotive garage space. U.S. Green Building Council, Underwriters Laboratories and CSA approved. Includes tamper-proof metal enclosure, sensor, fan actuator, weatherproof exhaust grille and cover, outlet duct and relay switch. Add for electrical connection.

Home garage exhaust fan, roof or upper sidewall mount, 110 volts.

118 CFM	SW@2.00	Ea	533.00	85.10	618.10
235 CFM	SW@2.00	Ea	595.00	85.10	680.10
416 CFM	SW@2.50	Ea	625.00	106.00	731.00

Parking garage exhaust fan, 208 volts, remote sensor controlled

400 CFM	SW@2.00	Ea	533.00	85.10	618.10
600 CFM	SW@2.00	Ea	595.00	85.10	680.10
800 CFM	SW@2.50	Ea	625.00	106.00	731.00
1,000 CFM	SW@2.75	Ea	678.00	117.00	795.00
1,500 CFM	SW@3.00	Ea	987.00	128.00	1,115.00
2,000 CFM	SW@3.50	Ea	1,250.00	149.00	1,399.00
Mount sensors	SW@.250	Ea	510.00	10.60	520.60
Apply fan frame sealant	SW@.150	LF	2.60	6.38	8.98
Install electrical wiring	BE@.150	LF	1.89	6.15	8.04
Install controls	BE@.500	Ea	—	20.50	20.50
Commission and test	P1@4.00	Ea	—	149.00	149.00

Fencing, Chain Link

Galvanized steel, 11.5 gauge 2" x 2" fence fabric, 2-3/8" terminal post with post caps, 1-5/8" line posts at 10' with loop line post caps, 1-3/8" top rail with rail ends, tension bands, tension bars and required bolts with nuts. Material includes 2/3 CF sack of concrete per post. Use 50 LF of fence as a minimum job cost.

36" high	BL@.125	LF	6.97	3.82	10.79	
42" high	BL@.125	LF	7.40	3.82	11.22	

Fencing, Chain Link

	Craft@Hrs	Unit	Material	Labor	Total
48" high	BL@.125	LF	8.01	3.82	11.83
60" high	BL@.125	LF	9.20	3.82	13.02
72" high	BL@.125	LF	10.50	3.82	14.32
Add for redwood filler strips	BL@.024	LF	5.35	.73	6.08
Add for aluminum filler strips	BL@.018	LF	6.30	.55	6.85
Add for PVC filler strips	BL@.018	LF	8.71	.55	9.26

Gates, driveway or walkway. Same construction as fencing shown above, assembled units ready to install. Add for gate hardware from below.

Driveway gates, costs per linear foot (LF)

36" high	BL@.025	LF	32.80	.76	33.56
42" high	BL@.025	LF	33.90	.76	34.66
48" high	BL@.025	LF	35.00	.76	35.76
60" high	BL@.033	LF	36.80	1.01	37.81
72" high	BL@.033	LF	39.10	1.01	40.11

3'6" wide walkway gate, costs per gate

36" high	BL@.500	Ea	135.00	15.30	150.30
42" high	BL@.500	Ea	139.00	15.30	154.30
48" high	BL@.500	Ea	143.00	15.30	158.30
60" high	BL@.666	Ea	151.00	20.30	171.30
72" high	BL@.666	Ea	156.00	20.30	176.30

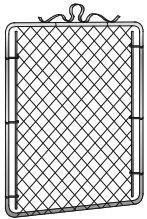

Add for gate hardware, per gate. Labor is included with labor shown for gate above. Includes latch, hanger brackets, bolts and hinge.

Driveway gate hardware

36" or 42" high	—	Ea	35.60	—	35.60
48" or 60" high	—	Ea	35.60	—	35.60
72" high	—	Ea	35.60	—	35.60

Walkway gate hardware

36" or 42" high	—	Ea	10.90	—	10.90
48" or 60" high	—	Ea	10.90	—	10.90
72" high	—	Ea	10.90	—	10.90

Pet enclosure fencing panels. Chain link fence, galvanized steel, 11 gauge, 2" x 2" mesh fence fabric, 1-3/8" tubular steel frame, does not include any foundation costs.

5'H x 3'W, panel	BL@.750	Ea	159.00	22.90	181.90
5'H x 4'W, panel	BL@.750	Ea	166.00	22.90	188.90
5'H x 6'W, panel	BL@.850	Ea	179.00	26.00	205.00
6'H x 3'W, panel	BL@.750	Ea	167.00	22.90	189.90
6'H x 4'W, panel	BL@.750	Ea	175.00	22.90	197.90
6'H x 6'W, panel	BL@.850	Ea	190.00	26.00	216.00
8'H x 6'W, panel	BL@1.00	Ea	230.00	30.60	260.60
5'H x 4'W, panel w/ gate	BL@1.00	Ea	335.00	30.60	365.60
5'H x 8'W, panel w/ gate	BL@1.50	Ea	362.00	45.80	407.80
6'H x 4'W, panel w/ gate	BL@1.00	Ea	351.00	30.60	381.60
6'H x 8'W, panel w/ gate	BL@1.50	Ea	381.00	45.80	426.80
8'H x 6'W, panel w/ gate	BL@4.75	Ea	437.00	145.00	582.00

Fence, Galvanized Wire Mesh With 1-5/8" galvanized steel posts, set without concrete 10' OC.

12-1/2 gauge steel, 12" vertical wire spacing

36" high, 6 horizontal wires	BL@.127	LF	3.32	3.88	7.20
48" high, 8 horizontal wires	BL@.127	LF	3.48	3.88	7.36
60" high, 8 horizontal wires	BL@.127	LF	3.89	3.88	7.77
72" high, 8 horizontal wires	BL@.127	LF	4.14	3.88	8.02



Fence Post Holes

	Craft@Hrs	Unit	Material	Labor	Total
11 gauge fence fabric, 9" vertical wire spacing					
42" high, 8 horizontal wires	BL@.127	LF	2.83	3.88	6.71
48" high, 9 horizontal wires	BL@.127	LF	3.11	3.88	6.99
14 gauge fence fabric, 6" vertical wire spacing					
36" high, 8 horizontal wires	BL@.127	LF	3.39	3.88	7.27
48" high, 9 horizontal wires	BL@.127	LF	3.08	3.88	6.96
60" high, 10 horizontal wires	BL@.127	LF	3.36	3.88	7.24
Add for components for electrified galvanized wire mesh fence					
15 gauge aluminum wire, single strand	BL@.050	LF	.28	1.53	1.81
12-1/2 gauge barbed wire, 4 barbs per LF	BL@.050	LF	.18	1.53	1.71
Charging unit for electric fence, Solar powered, 10 mile range, built in 6V battery	BL@.500	Ea	199.00	15.30	214.30
Charging unit, Solar powered, 3 mile range, indoors or out	BL@.500	Ea	137.00	15.30	152.30
Charging unit, 110V, 15 mile range, indoors or out	BL@.500	Ea	52.80	15.30	68.10
Fence stays for barbed wire, 48" high	BL@.250	Ea	1.28	7.64	8.92
Accessories for electric fencing					
Warning sign, yellow with black lettering	BL@.125	Ea	1.17	3.82	4.99
Add for polyethylene insulators	BL@.250	Ea	.31	7.64	7.95
Add for non-conductive gate fastener	BL@.500	Ea	5.70	15.30	21.00
Add for lightning arrester kit	BL@.500	Ea	13.60	15.30	28.90

Fence Post Holes

Based on holes 1' diameter and 2' deep with easy access on level terrain. Adjustments for other conditions are below. Per hole dug.

Excavate post hole by hand

Light soil, sand or loam	BL@.400	Ea	—	12.20	12.20
Medium soil, gravel or light clay	BL@.600	Ea	—	18.30	18.30
Heavy soil, shale, sandstone, rocky	BL@1.00	Ea	—	30.60	30.60

Excavate post hole with power auger. Add the auger cost.

Light soil, sand or loam	BL@.200	Ea	—	6.11	6.11
Medium soil, gravel or light clay	BL@.250	Ea	—	7.64	7.64
Heavy soil, shale, sandstone, rocky	BL@.300	Ea	—	9.17	9.17

Setting Fence Posts

Posts set with concrete, including temporary 1" x 6" bracing and stakes. Heights to 6'. Concrete assumes post hole is 1' x 1' x 2' deep. Per post set, using either wood or metal post.

Set and brace wood or metal fence post

Lay in gravel for drainage	BL@.010	Ea	.02	.31	.33
Set 4" x 4" x 8' treated wood post	BL@.015	Ea	11.70	.46	12.16
Set 18 gauge 1-7/8" metal tube post with cap	BL@.015	Ea	19.30	.46	19.76
Check and adjust post alignment	BL@.010	Ea	—	.31	.31
Plumb and brace post (5 uses)	BL@.100	Ea	.50	3.06	3.56
Backfill with concrete or soil	BL@.030	Ea	—	.92	.92
Tamp soil or rod concrete	BL@.010	Ea	—	.31	.31
Trowel drainage crown	BL@.010	Ea	—	.31	.31
Strip bracing and inspect	BL@.020	Ea	—	.61	.61
Concrete for post base, 60 lb. sack, mixed	BL@.125	Ea	3.63	3.82	7.45
Total per fence post (wood)	BL@.330	Ea	15.85	10.11	25.95
Wood posts 10' OC, per LF of fence	BL@.033	LF	1.59	1.01	2.60
Total per fence post (metal)	BL@.330	Ea	23.45	10.11	33.56
Metal posts 10' OC, per LF of fence	BL@.033	LF	2.35	1.01	3.36

Fencing, Wood

	Craft@Hrs	Unit	Material	Labor	Total
Setting Fence Rail on Wood Posts					
Stringing 2" x 4" wood rail between fence posts, including two 2" x 4" pressure treated rails at \$.76 per linear foot.					
Measure opening between posts	BL@.010	Ea	—	.31	.31
Measure and cut two treated rails	BL@.015	Ea	22.00	.46	22.46
Measure rail position on post	BL@.010	Ea	—	.31	.31
Nail one end in place	BL@.010	Ea	.02	.31	.33
Position other end and check for level	BL@.020	Ea	—	.61	.61
Nail second end in place	BL@.010	Ea	.02	.31	.33
Recheck level and adjust as needed	BL@.015	Ea	—	.46	.46
Paint cut ends, post connections, rail side	BL@.100	Ea	—	3.06	3.06
Set two rails nailed in place, total	BL@.190	Ea	22.04	5.83	27.87
Set two rails, per LF of fence, 10' rails	BL@.019	LF	2.20	1.16	3.36
Setting Fence Rail on Metal Posts					
Stringing 2" x 4" wood fence rail between metal posts, including 2" x 4" pressure treated rail at \$.76 per linear foot and one 5" lag bolt connecting adjacent rail at each post.					
Measure opening between posts	BL@.010	Ea	—	.31	.31
Measure and cut two 10' rail	BL@.030	Ea	22.00	.92	22.92
Measure rail position on post	BL@.010	Ea	—	.31	.31
Drill 2 rail and metal tube post for lag bolt	BL@.167	Ea	—	5.10	5.10
Set two rail on tube post with lag bolt	BL@.133	Ea	1.54	4.06	5.60
Recheck level and adjust as needed	BL@.015	Ea	—	.46	.46
Paint cut ends, post connections, rail side	BL@.100	Ea	—	3.06	3.06
Set two rails, bolted in place, total	BL@.465	Ea	23.54	14.22	37.76
Set two rails, bolted in place, per LF of fence	BL@.047	LF	2.35	1.42	3.78
Installing Fence Face Board					
Hand nailing or stapling face board (pickets) to existing rail. Deduct 50% from labor costs for power nailing or power stapling. Includes measuring and cutting each picket, nailing or stapling to the top rail, plumbing with a level and nailing or stapling to the bottom rail. Two nails or staples at each rail. Cost per LF of fence. Based on 1" x 4" x 6', 1" x 6" x 6' and 1" x 8" x 6' face boards. Face board costs vary widely.					
Nailing 4" wide pressure treated southern pine fence face board (3.4 per LF of fence)					
French gothic, 1" x 4" x 3-1/2'	BL@.102	LF	3.62	3.12	6.74
French gothic, 5/8" x 4" x 4'	BL@.102	LF	6.70	3.12	9.82
Dog-eared, 7/16" x 4" x 6'	BL@.136	LF	5.09	4.15	9.24
Dog-eared, 1" x 4", 6'	BL@.136	LF	7.65	4.15	11.80
Nailing 5-1/2" wide pressure treated southern pine fence face board (2.4 per LF of fence)					
Dog-eared, 5/8" x 5-1/2" x 6'	BL@.120	LF	4.75	3.67	8.42
Nailing 6" wide pressure treated southern pine fence face board (2.2 per LF of fence)					
Dog-eared, 1" x 6" x 6'	BL@.110	LF	6.00	3.36	9.36
Dog-eared premium S4S, 1" x 6" x 6'	BL@.110	LF	6.86	3.36	10.22
Full cut premium, 1" x 6" x 6'	BL@.110	LF	6.45	3.36	9.81
Dog-eared, 5/8" x 5-1/2" x 8'	BL@.110	LF	6.78	3.36	10.14
Nailing 4" wide white wood fence face board (3.4 per LF of fence)					
Gothic, 3/4" x 4" x 6'	BL@.136	LF	6.81	4.15	10.96
Flat top, 1" x 4" x 6'	BL@.136	LF	6.95	4.15	11.10
Dog-eared, 1" x 4" x 6'	BL@.136	LF	7.43	4.15	11.58
Dog-eared, 1" x 4" x 8'	BL@.136	LF	7.01	4.15	11.16

Fencing, Wood

	Craft@Hrs	Unit	Material	Labor	Total
Nailing 4" wide cedar fence face board (3.4 per LF of fence)					
Dog-eared, No. 2, 3/4" x 4" x 8'	BL@.136	LF	12.10	4.15	16.25
Gothic, 3/4" x 4" x 6'	BL@.136	LF	7.38	4.15	11.53
Dog-eared, 9/16" x 4" x 6'	BL@.136	LF	6.73	4.15	10.88
Flat top, full-cut, 1" x 4" x 6'	BL@.136	LF	11.50	4.15	15.65
No. 1 flat top, full-cut, 1" x 4" x 8'	BL@.136	LF	14.00	4.15	18.15
Nailing 6" wide cedar fence face board (2.2 per LF of fence)					
Dog-eared, No. 2, 9/16" x 6" x 6'	BL@.110	LF	6.93	3.36	10.29
Dog-eared, No. 2, 9/16" x 6" x 8'	BL@.110	LF	12.10	3.36	15.46
Dog-eared, clear, 1" x 6" x 6'	BL@.110	LF	8.96	3.36	12.32
Flat top, full-cut, 1" x 6" x 6'	BL@.110	LF	9.03	3.36	12.39
Nailing 4" wide dog-eared common redwood fence face board (3.4 per LF of fence)					
3/4" x 4" x 6'	BL@.136	LF	9.15	4.15	13.30
Nailing 6" wide dog-eared common redwood fence face board (2.2 per LF of fence)					
3/4" x 6" x 5'	BL@.110	LF	5.98	3.36	9.34
3/4" x 6" x 6'	BL@.110	LF	9.15	3.36	12.51
3/4" x 6" x 6'	BL@.110	LF	11.50	3.36	14.86
Nailing 8" wide dog-eared common redwood fence face board (1.6 per LF of fence)					
3/4" x 8" x 6'	BL@.088	LF	10.80	2.69	13.49
3/4" x 8" x 6' Premium Const. Heart	BL@.088	LF	16.50	2.69	19.19
1" x 8" x 8'	BL@.088	LF	22.20	2.69	24.89
Nailing 10" wide dog-eared common redwood fence face board (1.3 per LF of fence)					
3/4" x 10" x 5'	BL@.072	LF	11.50	2.20	13.70
3/4" x 10" x 6'	BL@.072	LF	12.60	2.20	14.80
Nailing 12" wide dog-eared common redwood fence face board (1.05 per LF of fence)					
3/4" x 12" x 5' Rough	BL@.063	LF	12.70	1.92	14.62
3/4" x 12" x 6'	BL@.063	LF	14.10	1.92	16.02
Nailing 6" wide flat top redwood fence face board (2.2 per LF of fence)					
3/4" x 6" x 6' Const. Heart	BL@.110	LF	12.40	3.36	15.76
3/4" x 6" x 6' Merch. and Better	BL@.110	LF	12.10	3.36	15.46
3/4" x 6" x 6' Ridge Valley Redwood	BL@.110	LF	18.20	3.36	21.56
3/4" x 6" x 8' Ridge Valley Redwood	BL@.110	LF	30.50	3.36	33.86
Nailing 8" wide flat top redwood fence face board (1.6 per LF of fence)					
3/4" x 8" x 5'	BL@.088	LF	9.17	2.69	11.86
3/4" x 8" x 5' T&G	BL@.088	LF	13.30	2.69	15.99
3/4" x 8" x 6'	BL@.088	LF	10.50	2.69	13.19
3/4" x 8" x 6' Construction Heart	BL@.088	LF	18.20	2.69	20.89
1" x 8" x 8' Construction Heart	BL@.088	LF	22.20	2.69	24.89
Nailing 10" and 12" wide flat top redwood fence face board (1.3 per LF of fence for 10", 1.0 for 12")					
3/4" x 10" x 8' Redwood	BL@.072	LF	16.10	2.20	18.30
3/4" x 12" x 6' Dog-eared	BL@.072	LF	13.40	2.20	15.60
Deduct for power stapling or power nailing	—	%	—	-50.0	—

Building a Fence on a Hillside

Post hole excavation, post setting and fence erection will take longer when the site is obstructed or on a hillside. Adjust manhours as follows for sloping terrain.

Add for slope to 4 in 12	—	%	—	20.0	—
Add for slope over 4 in 12 to 8 in 12	—	%	—	50.0	—
Add for slope over 8 in 12 to 12 in 12	—	%	—	100.0	—

Fencing, Wood

	Craft@Hrs	Unit	Material	Labor	Total
Build and Hang a Wood Fence Gate 5' high by 3' wide wood gate, 2" x 4" frame . Add the cost of fence posts from above. Add fence face boards from above. Units are for each gate.					
Measure, design and lay out gate	BL@.200	Ea	—	6.11	6.11
Measure and cut frame (11' x 2" x 4")	BL@.050	Ea	10.10	1.53	11.63
Nail frame together	BL@.100	Ea	.10	3.06	3.16
Square up and measure 4' diagonal brace	BL@.050	Ea	3.67	1.53	5.20
Cut cross brace and nail in place	BL@.083	Ea	.08	2.54	2.62
Square up and add metal corner brackets	BL@.333	Ea	1.75	10.20	11.95
Mark top pattern on face boards	BL@.133	Ea	—	4.06	4.06
Cut top pattern on face boards	BL@.089	Ea	—	2.72	2.72
Set hinges on gate and fence post	BL@.250	Ea	8.43	7.64	16.07
Set latch on gate and strike on fence post	BL@.100	Ea	7.35	3.06	10.41
Check and adjust as needed	BL@.125	Ea	—	3.82	3.82
Build and hang wood fence gate, total	BL@1.51	Ea	31.48	46.27	77.75

Fence Assemblies, Wood Costs shown include excavation of post holes, concrete and labor to set posts, attaching rails with nails or lag bolts, and hand nailing of face boards where applicable. See additional costs at the end of this section.

Basketweave fence, redwood, "B" grade, 1" x 6" boards, 2" x 4" stringers or spreaders, 4" x 4" posts

Tight weave, 4' high, posts at 4' OC	B1@.332	LF	16.40	11.30	27.70
Tight weave, 6' high, posts at 4' OC	B1@.522	LF	19.90	17.80	37.70
Wide span, 4' high, posts at 8' OC	B1@.291	LF	8.92	9.93	18.85
Wide span, 8' high, posts at 8' OC	B1@.481	LF	12.30	16.40	28.70
4' high gate, tight weave	B1@.906	Ea	72.30	30.90	103.20
4' high gate, wide span	B1@.906	Ea	87.70	30.90	118.60
6' high gate, tight weave	B1@1.11	Ea	39.30	37.90	77.20
8' high gate, wide span	B1@1.26	Ea	53.90	43.00	96.90

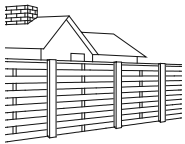

Board fence, using 4" wide boards, hand nailed, posts at 10' OC

Pressure treated Southern Pine, 1" x 4" boards					
6' high, 2 rail, wood posts	B1@.267	LF	8.14	9.11	17.25
6' high, 2 rail, metal posts	B1@.276	LF	9.08	9.41	18.49
Deduct for power stapling or power nailing	—	%	—	-22.0	—
Cedar, 1" x 4" boards					
6' high, 2 rail, wood posts	B1@.267	LF	13.80	9.11	22.91
8' high, 2 rail, wood posts	B1@.267	LF	16.00	9.11	25.11
6' high, 2 rail, metal posts	B1@.276	LF	14.70	9.41	24.11
8' high, 2 rail, metal posts	B1@.276	LF	16.80	9.41	26.21
Deduct for power stapling or power nailing	—	%	—	-22.0	—
Redwood, 3/4" x 4" boards					
6' high, 2 rail, wood posts	B1@.267	LF	11.70	9.11	20.81
6' high, 2 rail, metal posts	B1@.276	LF	12.70	9.41	22.11
Deduct for power stapling or power nailing	—	%	—	-22.0	—
Whitewoods, 1" x 4" boards					
6' high, 2 rail, wood posts	B1@.267	LF	9.79	9.11	18.90
8' high, 2 rail, wood posts	B1@.267	LF	9.84	9.11	18.95
6' high, 2 rail, metal posts	B1@.276	LF	10.70	9.41	20.11
8' high, 2 rail, metal posts	B1@.276	LF	10.80	9.41	20.21
Deduct for power stapling or power nailing	—	%	—	-22.0	—

Fencing, Wood

	Craft@Hrs	Unit	Material	Labor	Total
Board fence, using 6" wide boards, hand nailed, posts at 10' OC					
Pressure treated Southern Pine, 1" x 6" boards					
6' high, 2 rail, wood posts	B1@.241	LF	9.52	8.22	17.74
8' high, 2 rail, wood posts	B1@.241	LF	9.82	8.22	18.04
6' high, 2 rail, metal posts	B1@.250	LF	10.50	8.53	19.03
8' high, 2 rail, metal posts	B1@.250	LF	10.80	8.53	19.33
Deduct for power stapling or power nailing	—	%	—	-22.0	—
Cedar, 9/16" x 6" boards					
6' high, 2 rail, wood posts	B1@.241	LF	9.95	8.22	18.17
8' high, 2 rail, wood posts	B1@.241	LF	14.60	8.22	22.82
6' high, 2 rail, metal posts	B1@.250	LF	10.90	8.53	19.43
8' high, 2 rail, metal posts	B1@.250	LF	15.60	8.53	24.13
Deduct for power stapling or power nailing	—	%	—	-22.0	—
Redwood, 3/4" x 6" boards					
6' high, 2 rail, wood posts	B1@.241	LF	20.20	8.22	28.42
8' high, 2 rail, wood posts	B1@.241	LF	16.50	8.22	24.72
6' high, 2 rail, metal posts	B1@.250	LF	21.10	8.53	29.63
8' high, 2 rail, metal posts	B1@.250	LF	32.30	8.53	40.83
Deduct for power stapling or power nailing	—	%	—	-22.0	—
Split-rail fence, red cedar, 4" posts at 8' OC					
Split 2" x 4" rails, 3' high, 2 rail	B1@.095	LF	4.31	3.24	7.55
Split 2" x 4" rails, 4' high, 3 rail	B1@.102	LF	5.35	3.48	8.83
Rustic 4" round, 3' high, 2 rail	B1@.095	LF	5.21	3.24	8.45
Rustic 4" round, 4' high, 3 rail	B1@.102	LF	6.70	3.48	10.18
Picket fence, 1" x 2" pickets, 2" x 4" rails, 4" x 4" posts at 8' OC					
Pressure treated Southern Pine					
3' high, 2 rail	B1@.270	LF	2.72	9.21	11.93
5' high, 3 rail	B1@.385	LF	3.70	13.10	16.80
3' high gate	B1@.770	Ea	11.90	26.30	38.20
5' high gate	B1@.887	Ea	16.30	30.30	46.60
Red cedar, #3 & Better					
3' high, 2 rail	B1@.270	LF	5.19	9.21	14.40
5' high, 3 rail	B1@.385	LF	7.12	13.10	20.22
3' high gate	B1@.770	Ea	22.80	26.30	49.10
5' high gate	B1@.887	Ea	31.30	30.30	61.60
Redwood, B grade					
3' high, 2 rail	B1@.270	LF	6.78	9.21	15.99
5' high, 3 rail	B1@.385	LF	8.85	13.10	21.95
3' high gate	B1@.770	Ea	29.70	26.30	56.00
5' high gate	B1@.887	Ea	38.80	30.30	69.10
Picket fence gate hardware					
Latch, standard duty	B1@.281	Ea	4.72	9.58	14.30
Latch, heavy duty	B1@.281	Ea	15.80	9.58	25.38
Slide bolt	B1@.281	Ea	6.21	9.58	15.79
Hinges, standard, per pair	B1@.374	Pr	8.26	12.80	21.06
Hinges, heavy duty, per pair	B1@.374	Pr	11.50	12.80	24.30
No-sag cable kit	B1@.281	Ea	12.90	9.58	22.48
Self closing spring	B1@.281	Ea	14.60	9.58	24.18

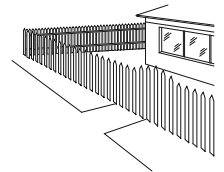

Fencing, Aluminum

Craft@Hrs Unit Material Labor Total

Fencing, Aluminum

Decorative aluminum, 72-1/2" panel width, 2" x 2" posts, .060" wall thickness, 3-13/16" picket spacing, 1" x .055" top rail with 1-1/2" x .082" sides. Pre-routed holes in posts. Gates include hardware. Pool code compliant model has 48" space between horizontal rails

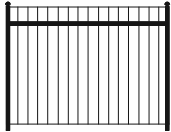

48" high panel	BL@.170	Ea	85.20	5.19	90.39
54" pool code compliant panel	BL@.170	Ea	93.20	5.19	98.39
60" high panel	BL@.170	Ea	102.00	5.19	107.19
72" high panel	BL@.170	Ea	129.00	5.19	134.19
Fence posts					
48" high	BL@.830	Ea	29.20	25.40	54.60
54" high	BL@.830	Ea	31.60	25.40	57.00
60" high	BL@.830	Ea	31.60	25.40	57.00
72" high	BL@.830	Ea	42.60	25.40	68.00
Single swing gates, 5' wide					
48" high	BL@.175	Ea	487.00	5.35	492.35
54" high	BL@.175	Ea	397.00	5.35	402.35
60" high	BL@.175	Ea	395.00	5.35	400.35
72" high	BL@.175	Ea	426.00	5.35	431.35
Gate posts					
48" high	BL@.830	Ea	48.70	25.40	74.10
54" high	BL@.830	Ea	54.70	25.40	80.10
60" high	BL@.830	Ea	54.70	25.40	80.10
72" high	BL@.830	Ea	62.00	25.40	87.40
Add for setting post in concrete	BL@.330	Ea	3.50	10.10	13.60

Fencing, Vinyl

Costs shown include concrete and labor to set posts.

Vinyl picket fence, 1-1/2" pickets with 2" spacing, 2 rail, 2" x 4" rails, 4" x 4" posts at 8' OC, pre-assembled in 8' sections. Prices include post mounts, post top, screws and one post.

4' high	B1@.110	LF	21.60	3.75	25.35
Gate with 4" posts	B1@1.00	Ea	422.00	34.10	456.10
Add for additional fence post with top	B1@.500	Ea	26.60	17.10	43.70

Vinyl picket fence, 3-1/2" pickets with 3" spacing, 2 rail, 2" x 4" rails, 4" x 4" posts at 6' OC, pre-assembled in 6' sections. Prices include post mounts, post top, screws and one post.

4' high	B1@.110	LF	21.60	3.75	25.35
Gate with 4" posts	B1@1.00	Ea	422.00	34.10	456.10
Add for additional fence post with top	B1@.500	Ea	26.60	17.10	43.70

Vinyl shadowbox fence, 5-1/2" pickets on alternate sides of fence rail., 3 rail, with galvanized steel support, posts at 71" OC. Prices include post mounts, post top, screws and one post.

4' high	B1@.130	LF	28.60	4.43	33.03
5' high	B1@.140	LF	30.30	4.78	35.08
6' high	B1@.140	LF	32.30	4.78	37.08
Gate with 4" posts	B1@1.20	Ea	597.00	40.90	637.90
Add for additional fence post with top	B1@.500	Ea	33.30	17.10	50.40

Vinyl privacy fence, 6" boards, 3 rail, posts at 6' OC. Prices include post mounts, post top, screws and one post.

6' high	B1@.140	LF	33.80	4.78	38.58
6' x 44" high gate	B1@1.20	Ea	614.00	40.90	654.90
Add for additional fence post with top	B1@.500	Ea	35.00	17.10	52.10

Vinyl post & rail fence, 2" x 6" x 96" notched rail, posts 8' OC. Includes post mounts, post top, and one post.

42" high, 2 rail, 4" routed post	B1@.110	LF	5.69	3.75	9.44
48" high, 3 rail, 4" routed post	B1@.120	LF	7.05	4.09	11.14
54" high, 4 rail, 5" routed post	B1@.120	LF	8.88	4.09	12.97
48" gate with 4" posts	B1@1.00	Ea	242.00	34.10	276.10
54" gate with 5" posts	B1@1.00	Ea	287.00	34.10	321.10
Add for additional 4" fence post with top	B1@.500	Ea	19.00	17.10	36.10
Add for additional 5" fence post with top	B1@.500	Ea	23.90	17.10	41.00

Fire Sprinkler Systems

	Craft@Hrs	Unit	Material	Labor	Total
Silt fence , black 6 mil poly with stakes 8' OC, staked and buried 9" deep 3' high, 100 LF roll	BL@.030	LF	.53	.92	1.45
Fiberglass and Polycarbonate Panels Nailed or screwed onto wood frame. Corrugated polycarbonate, 8', 10', 12' panels, 2-1/2" corrugations, standard colors. Costs include 10% loss for coverage and waste.					
Polycarbonate, 26" wide, gray or white	BC@.012	SF	1.44	.45	1.89
Polycarbonate, 26" wide, clear	BC@.012	SF	1.44	.45	1.89
PVC, 26" wide panels	BC@.012	SF	.98	.45	1.43
Corrugated fiberglass, 8', 10', 12' panels, 2-1/2" corrugations, standard colors. Costs include 10% loss for coverage and waste.					
Fiberglass, 26" wide, gray or white	BC@.012	SF	3.05	.45	3.50
Fiberglass, 26" wide, clear	BC@.012	SF	3.05	.45	3.50
Flat panels, clear, green or white					
.06" flat sheets, 4' x 8', 10', 12'	BC@.012	SF	4.30	.45	4.75
.03" rolls, 24", 36", 48" x 50'	BC@.012	SF	3.66	.45	4.11
.037" rolls, 24", 36", 48" x 50'	BC@.012	SF	3.17	.45	3.62
Accessories					
Nails, ring shank with rubber washer, 1-3/4" (labor included with panels)					
100 per box (covers 130 SF)	—	CSF	3.79	—	3.79
Self-tapping screws, 1-1/4", rust-proof (labor included with panels)					
100 per box (covers 130 SF)	—	CSF	5.07	—	5.07
Horizontal closure strips, corrugated (labor included with panels)					
Molded plastic, 3/4" x 1-1/4"	—	LF	.57	—	.57
Wood, 3/4" x 13/16"	—	LF	.77	—	.77
Poly-foam, 15/16" x 3/4"	—	LF	.64	—	.64
Rubber, 1" x 1"	—	LF	.80	—	.80
Vertical crown molding					
Redwood, 1-1/2" x 1" or poly-foam, 1" x 1"	—	LF	.57	—	.57
Rubber, 1" x 1"	—	LF	1.47	—	1.47
Ridge cap, covers the joint where panels meet at the roof peak					
Polycarbonate, 48" long	—	LF	6.68	—	6.68
Ornamental Iron, Railings and Fence, Subcontract Typical prices, fabricated, delivered and installed.					
Handrail, 1-1/2" x 1" rectangular top rail tubing, 1" square bottom rail tubing, 1/2" square pickets with 5-1/2" space between					
36" high railing for single family dwelling	—	LF	—	—	43.90
42" high apartment style railing	—	LF	—	—	35.00
Add for inclined runs	—	LF	—	—	8.06
Pool fence					
5' high, 4-1/2" centers	—	LF	—	—	43.90
Add for gate, with self-closer and latch	—	LS	—	—	207.00
Fire Sprinkler Systems, Subcontract Systems installed in new residences not over four stories high in accord with NFPA 13D and 13R. Includes hydraulic design, typical permits and tap fees (\$350), connection to a domestic water line, exposed riser with shut-off and drain valves, flow switch, alarm, backflow preventer and inspection of the completed system. Using CPVC or PEX concealed pipe and residential sprinkler heads. Per SF of protected area, including closets, attached garage, attic and basement when required. For scheduling purposes, estimate that a crew of 2 can install the rough-in piping for 1,500 to 1,600 SF of protected area in an 8-hour day and about the same amount of finish work in another 8-hour day.					
Fabricate, install, and test system					
Single residence, slab foundation	—	SF	—	—	1.67
Single residence, crawl space foundation	—	SF	—	—	1.92
Single residence with basement	—	SF	—	—	2.07
Tract work or multi-family residence	—	SF	—	—	1.76
Add if copper pipe is required	—	SF	—	—	2.07
Add if a booster pump is required (well water)	—	LS	—	—	3,570.00

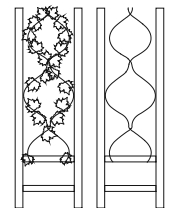
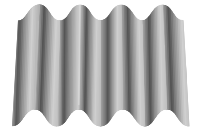
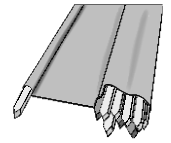

Fireplaces

Craft@Hrs Unit Material Labor Total

Masonry Fireplaces

Fire box lined with refractory firebrick, backed with common brick and enclosed in a common brick wall. Includes fireplace throat and smoke chamber. Overall height of the fireplace and throat is 5'. Chimney (flue) is made from common brick and a flue liner. Including lintels, damper and 12" thick reinforced concrete foundation. For more on masonry fireplaces, see *National Concrete & Masonry Estimator*, <https://craftsman-book.com/national-estimator-cloud>.

30" wide x 29" high x 16" deep fire box	B9@39.7	LS	701.00	1,320.00	2,021.00
36" wide x 29" high x 16" deep fire box	B9@43.5	LS	739.00	1,450.00	2,189.00
42" wide x 32" high x 16" deep fire box	B9@48.3	LS	816.00	1,610.00	2,426.00
48" wide x 32" high x 18" deep fire box	B9@52.8	LS	897.00	1,760.00	2,657.00
12" x 12" chimney to 12' high	B9@9.50	LS	415.00	317.00	732.00
Add for higher chimney, per LF	B9@1.30	LF	56.60	43.40	100.00
Add for 8" x 10" ash cleanout door	B9@.500	SF	18.30	16.70	35.00
Add for combustion air inlet kit	B9@.750	SF	27.60	25.00	52.60
Add for common brick veneer interior face	B9@.451	SF	5.18	15.00	20.18
Add for rubble or cobble stone veneer face	B9@.480	SF	14.20	16.00	30.20
Add for limestone veneer face or hearth	B9@.451	SF	26.80	15.00	41.80
Add for 1-1/4" marble face or hearth	B9@.451	SF	39.20	15.00	54.20
Add for modern design 11" x 77" pine mantel	B1@3.81	Ea	794.00	130.00	924.00
Add for gas valve, log lighter and key	PM@.750	Ea	74.50	32.90	107.40

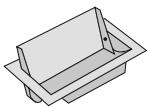

Angle iron (lintel support), lengths 25" to 96" 3" x 3" x 3/16"	B9@.167	LF	5.29	5.57	10.86
--	---------	----	------	------	-------

Ash drops, cast iron top, galvanized container 16-3/4" x 12-1/2" x 8"	B9@.750	Ea	586.50	25.00	611.50
--	---------	----	--------	-------	--------

Ash dumps, cast iron 5-3/8" x 9-1/2" overall	B9@.500	Ea	16.80	16.70	33.50
5-3/8" x 9-1/2" overall, vented	B9@.500	Ea	33.70	16.70	50.40

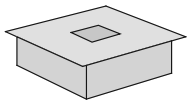

Chimney anchors, per pair 48" x 1-1/2" x 3/16"	—	Pr	13.10	—	13.10
72" x 1-1/2" x 3/16"	—	Pr	17.40	—	17.40

Cleanout doors, cast iron, overall dimensions 8" wide x 8" high	B9@.500	Ea	46.60	16.70	63.30
12" wide x 10" high	B9@.500	Ea	78.30	16.70	95.00
12" wide x 12" high	B9@.500	Ea	91.20	16.70	107.90

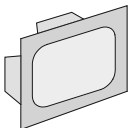

Dampers for single opening firebox, heavy steel with rockwool insulation 14" high, 25" to 30" wide, 10" deep, 25 lbs	B9@1.33	Ea	60.50	44.40	104.90
14" high, 36" wide, 10" deep, 31 lbs	B9@1.33	Ea	65.50	44.40	109.90
14" high, 42" wide, 10" deep, 38 lbs	B9@1.33	Ea	80.10	44.40	124.50
14" high, 48" wide, 10" deep, 43 lbs	B9@1.75	Ea	103.00	58.40	161.40
16" high, 54" wide, 13" deep, 66 lbs	B9@2.50	Ea	178.00	83.40	261.40
16" high, 60" wide, 13" deep, 74 lbs	B9@2.50	Ea	214.00	83.40	297.40
16" high, 72" wide, 13" deep, 87 lbs	B9@2.50	Ea	257.00	83.40	340.40

Dampers for multiple opening or corner opening firebox, high capacity, steel downdraft shelf support 35" wide	B9@1.33	Ea	248.00	44.40	292.40
41" wide	B9@1.33	Ea	283.00	44.40	327.40
47" wide	B9@1.75	Ea	363.00	58.40	421.40

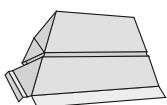

Chimney-top dampers, with cable to the firebox and handle mount, aluminum, by flue size 8" x 8"	B9@1.33	Ea	207.00	44.40	251.40
8" x 13", with 3/4" mesh	B9@1.33	Ea	296.00	44.40	340.40
8" x 17"	B9@1.33	Ea	269.00	44.40	313.40
13" x 13"	B9@1.75	Ea	213.00	58.40	271.40
13" x 17"	B9@2.50	Ea	306.00	83.40	389.40
17" x 17"	B9@2.50	Ea	364.00	83.40	447.70

Fireplaces

	Craft@Hrs	Unit	Material	Labor	Total
Fuel grates, steel bar fireplace grates					
27" with 5/8" bar	—	Ea	88.20	—	88.20
30" with 3/4" bar	—	Ea	138.00	—	138.00
36" with 3/4" bar	—	Ea	171.00	—	171.00

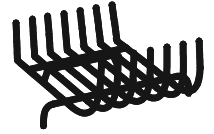

Factory-built wood-burning fireplaces Including refractory-lined firebox, fireplace front, combustion air kit and damper with control. By hearth opening width. 21" depth overall.

36" wide	B9@3.50	Ea	819.00	117.00	936.00
42" wide	B9@3.50	Ea	1,250.00	117.00	1,367.00
50" wide	B9@4.00	Ea	3,750.00	133.00	3,883.00
36" wide, 1 open end	B9@3.50	Ea	1,850.00	117.00	1,967.00
36" wide, 3 open sides	B9@4.00	Ea	2,590.00	133.00	2,723.00
42" wide, see-through	B9@4.00	Ea	3,190.00	133.00	3,323.00
25" wide, EPA Phase II compliant	B9@4.00	Ea	6,890.00	133.00	7,023.00
Add for 8" Class A vent, per vertical foot	B9@.250	LF	171.00	8.34	179.34

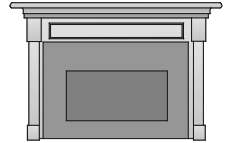

Gas-burning direct vent zero clearance fireplaces Vents directly through an exterior wall or the roof using sealed double chamber vent pipe. See vent pipe costs below. Waste gases exit through the vent inner chamber. Outside air enters the firebox through the vent outside chamber. Framing may be applied directly against the unit. Circulates heated air into the room. Includes brick firebox, fireplace front, bi-fold glass doors, temperature control, masonry logs and fuel grate. Electric ignition. Overall dimensions.

39" high x 36" wide x 21" deep	B9@3.50	Ea	1,920.00	117.00	2,037.00
39" high x 41" wide x 19" deep	B9@3.50	Ea	1,920.00	117.00	2,037.00
38" high x 36" wide x 18" deep	B9@3.50	Ea	2,260.00	117.00	2,377.00
33" high x 42" wide x 24" deep, 1 open end	B9@3.50	Ea	4,230.00	117.00	4,347.00
38" high x 40" wide x 24" deep, 2 open ends	B9@4.00	Ea	4,690.00	133.00	4,823.00
30" high x 38" wide x 24" deep, see-through	B9@4.00	Ea	3,720.00	133.00	3,853.00
Deduct for conventional B-vent units	—	Ea	-192.00	—	-192.00

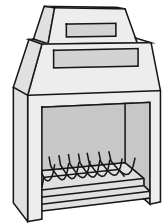

Direct vent fireplace flue (chimney), double wall, typical cost for straight vertical installation

4" inside diameter 6-5/8" outside diameter	B9@.167	LF	14.60	5.57	20.17
5" inside diameter, 8" outside diameter	B9@.167	LF	18.10	5.57	23.67
Flue spacers, for passing through ceiling					
1" or 2" clearance	B9@.167	Ea	15.90	5.57	21.47
Typical flue offset	B9@.250	Ea	99.90	8.34	108.24
Flashing and storm collar, one required per roof penetration					
Flat to 6/12 pitch roofs	B9@3.25	Ea	63.50	108.00	171.50
6/12 to 12/12 pitch roofs	B9@3.25	Ea	92.30	108.00	200.30
Spark arrestor top	B9@.500	Ea	129.00	16.70	145.70

Blower kit for heat-circulating fireplace, requires 110 volt electrical receptacle outlet (electrical wiring not included)

Blower unit for connection to existing outlet	B9@.500	Ea	116.00	16.70	132.70
Add variable speed and thermostatic control	B9@.100	Ea	84.40	3.34	87.74

Electric fireplaces, built-in Prefabricated, 120 volt, including grate, ember bed, interior face, thermostat, brightness control and logs.

25" wide opening, 120 volt, 1,500 watts	B9@2.50	Ea	919.00	83.40	1,002.40
26" wide opening, 120 volt, 1,500 watts	B9@2.50	Ea	1,330.00	83.40	1,413.40

Flooring, Vinyl Sheet

Craft@Hrs Unit Material Labor Total

Sheet Vinyl Flooring

Armstrong sheet vinyl flooring. By Performance Appearance Rating (PAR). Bonded with adhesive at perimeter and at seams. Including 10% waste and adhesive.

Medley, urethane wear layer, 15 year	BF@.250	SY	23.70	8.65	32.35
Caspian, PAR 3.8, urethane wear layer, 15 year	BF@.250	SY	19.20	8.65	27.85
Themes, PAR 2.9, urethane wear layer, 10 year	BF@.250	SY	14.70	8.65	23.35
Sundial, urethane wear layer, .098", 10 year	BF@.250	SY	16.10	8.65	24.75
Metro, PAR 2.3, vinyl wear layer, 5 year	BF@.250	SY	8.41	8.65	17.06
Cambray FHA, PAR 1.7, vinyl wear layer, 5 year	BF@.250	SY	8.41	8.65	17.06
Memories, 12 year	BF@.250	SY	27.90	8.65	36.55
Successor, 10 year	BF@.250	SY	21.00	8.65	29.65
Enhancements, 6 year	BF@.250	SY	21.30	8.65	29.95
Initiator, 5 year	BF@.250	SY	14.50	8.65	23.15
Sentinel, 5 year	BF@.250	SY	11.80	8.65	20.45
Apartment One, 1 year	BF@.250	SY	11.50	8.65	20.15
Royelle, PAR 1.3, vinyl wear layer, 1 year	BF@.250	SY	5.85	8.65	14.50

Tarkett sheet vinyl, bonded with adhesive at perimeter and at seams. Including 10% waste and adhesive.

Simply Brite	BF@.250	SY	34.60	8.65	43.25
Signature	BF@.250	SY	29.90	8.65	38.55
Naturelle	BF@.250	SY	29.30	8.65	37.95
Presence Felt	BF@.250	SY	22.90	8.65	31.55
Style Brite Flex	BF@.250	SY	19.70	8.65	28.35
Style Brite Felt	BF@.250	SY	19.60	8.65	28.25
Simply Brite Felt	BF@.250	SY	19.40	8.65	28.05
Fiber Floor	BF@.250	SY	11.50	8.65	20.15
Sierra	BF@.250	SY	10.40	8.65	19.05
Yosemite	BF@.250	SY	9.36	8.65	18.01
Preference	BF@.250	SY	8.20	8.65	16.85
Sandran	BF@.250	SY	5.44	8.65	14.09

Sheet vinyl, no wax, Mannington. Bonded with adhesive at perimeter and at seams. Including 10% waste and adhesive.

Gold Series	BF@.250	SY	51.40	8.65	60.05
Silver Series	BF@.250	SY	36.60	8.65	45.25
Bronze Series	BF@.250	SY	36.60	8.65	45.25
Villa Series	BF@.250	SY	26.20	8.65	34.85
Ceramica	BF@.250	SY	32.80	8.65	41.45
Silverado	BF@.250	SY	29.70	8.65	38.35
Aurora	BF@.250	SY	26.50	8.65	35.15
Lumina	BF@.250	SY	21.90	8.65	30.55
Vega II, Omni	BF@.250	SY	17.10	8.65	25.75

Vinyl 12" x 12" Tile Flooring

Armstrong vinyl tile, 12" x 12", including 10% waste and adhesive

Solarian Stonegate, .094"	BF@.023	SF	3.71	.80	4.51
Natural Images, .094"	BF@.023	SF	3.71	.80	4.51
Chelsea (urethane), .08"	BF@.023	SF	2.97	.80	3.77
Chesapeake (urethane), .08"	BF@.023	SF	2.42	.80	3.22
Harbour, .08"	BF@.023	SF	2.29	.80	3.09
StoneTex, 1/8"	BF@.021	SF	2.07	.73	2.80
Stylistik, .065", self-adhesive	BF@.023	SF	1.64	.80	2.44
Themes, .08" (urethane)	BF@.023	SF	1.68	.80	2.48
Vernay, Metro, .045"	BF@.023	SF	1.40	.80	2.20
MultiColor, 1/8"	BF@.021	SF	1.19	.73	1.92
Excelon Civic Square, 1/8"	BF@.021	SF	.89	.73	1.62
Afton, .075"	BF@.023	SF	1.52	.80	2.32
Builder urethane, .080", self-adhesive	BF@.023	SF	2.54	.80	3.34
Builder urethane, .080", dry back	BF@.023	SF	2.42	.80	3.22

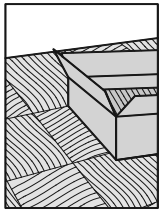

Flooring, Vinyl Tile

	Craft@Hrs	Unit	Material	Labor	Total
Elegant Images™ Series vinyl floor tile, Armstrong. 12" x 12". ToughGuard® durability. Resists stains, scratches, scuffs and indentations. 25-year warranty. Per square foot, including adhesive and 10% waste.					
Cornwall, Burnt Almond	BF@.023	SF	3.13	.80	3.93
Modern, Rose/Green Inset	BF@.023	SF	2.11	.80	2.91
Rubber studded tile. 12" x 12". Highly resilient to reduce fatigue. 10-year wear warranty. Slip-resistant. Sound absorbent. High abrasion resistance. For kitchens and utility rooms.					
All colors	BF@.025	SF	9.18	.86	10.04
Vinyl Flooring Accessories					
Resilient flooring adhesive					
Sheet vinyl adhesive, per gallon	—	Gal	25.30	—	25.30
Sheet vinyl adhesive, 71 SF per gallon	—	SF	.39	—	.39
Vinyl tile adhesive, per gallon	—	Gal	29.00	—	29.00
Vinyl tile adhesive, 190 SF per gallon	—	SF	.17	—	.17
Vinyl seam sealer kit (100 LF)	—	LF	.12	—	.12
Resilient flooring accessories					
Self-leveling compound					
1 pound per SF at .25" depth	BF@.016	SF	.69	.55	1.24
Latex masonry primer (used over dusting, porous or below grade concrete)					
100 SF per gallon	BF@.008	SF	.30	.28	.58
Liquid underlay (application over existing vinyl floor)					
Gallon covers 52 SF	BF@.010	SF	.87	.35	1.22
Lining felt, 15 Lb. asphalt felt (used over board subfloor)					
432 SF roll covers 350 SF	BF@.004	SF	.05	.14	.19
Tempered hardboard underlayment (levels uneven subfloor)					
1/8" x 4' x 8' sheet	BF@.016	SF	.38	.55	.93
Cove base, colors,					
2-1/2" high, .08" thick	BF@.025	LF	1.10	.86	1.96
4" high, .08" thick	BF@.025	LF	.81	.86	1.67
4" high, self-adhesive	BF@.016	LF	1.02	—	—
.55 —	LF	.12	—	.12	—
Accent strip, 1/8" x 24" long					
1/2" wide	BF@.025	LF	.40	.86	1.26
1" wide	BF@.025	LF	.51	.86	1.37
2" wide	BF@.025	LF	.96	.86	1.82
Vinyl edging strip, 1" wide					
1/16" thick	—	LF	.67	—	.67
1/8" thick	—	LF	.84	—	.84
Vinyl Plank Flooring (LVP). Luxury vinyl plank and tile consists of a clear wear layer, an embossed vinyl layer, a composite core and a cushion layer. Many colors and textures. Surface can look like wood, stone, travertine or marble. Planks are from 6" wide to 4' long and 8 mm to 12 mm thick. Floating plank is secured only at room edges with base molding. Includes 15% cutting waste.					
Economy, glue-down	BF@.051	SF	3.10	1.76	4.86
Most colors and textures, floating	BF@.051	SF	4.11	1.76	5.87
Premium -- high traffic, waterproof, deep colors	BF@.051	SF	4.54	1.76	6.30
Tread and riser, glue-down, with nosing, per stair	BF@.881	Ea	112.00	30.50	142.50
T mold strip (joins same level surface)	BF@.040	LF	5.52	1.38	6.90
Reducer strip (joins higher surface)	BF@.040	LF	4.20	1.38	5.58
End molding (joins lower surface)	BF@.040	LF	5.52	1.38	6.90
Wall base, to 4" high	BF@.040	LF	1.44	1.38	2.82
Scribe and seal around irregular surface (masonry)					
	BF@.554	LF	1.00	19.20	20.20
Add for floor prep, per room, typical	BF@1.50	Ea	2.14	51.90	54.04
Add for small or irregular rooms	BF@.011	SF	—	.38	.38
Add for diagonal patterns	BF@.004	SF	—	.14	.14

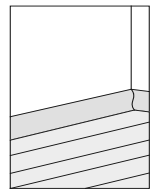

Flooring, Wood Strip

Craft@Hrs Unit Material Labor Total

Wood Strip Flooring Unfinished tongue and groove 3/4" x 2-1/4" strip flooring. Bundle covers 19.5 square feet. See installation, sanding and finishing cost below.

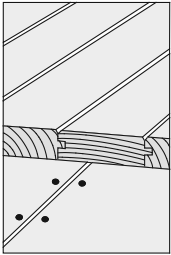

Select red oak, 19.5 SF per bundle	—	SF	6.00	—	6.00
Select white oak, 19.5 SF per bundle	—	SF	6.00	—	6.00
No. 1 common red oak, 19.5 SF per bundle	—	SF	4.28	—	4.28
No. 1 common white oak, 19.5 SF per bundle	—	SF	4.75	—	4.75
No. 2 common red oak, 19.5 SF per bundle	—	SF	2.64	—	2.64
Select ash, 19.5 SF per bundle	—	SF	5.29	—	5.29
Red oak stair nosing, 3/4"	—	LF	10.40	—	10.40
Red oak reducer strip, 3/4" x 2"	—	LF	3.28	—	3.28
Red oak quarter round, 3/4" x 3/4"	—	LF	1.23	—	1.23

Labor installing, sanding and finishing hardwood strip flooring on a prepared subfloor. Nailed in place.

Install 1-1/2" width strips	BF@.066	SF	—	2.28	2.28
Install 2" or 2-1/4" width strips	BF@.062	SF	—	2.14	2.14
Install 3-1/4" width strips	BF@.060	SF	—	2.08	2.08
Install stair nose or reducer strip	BF@.040	LF	—	1.38	1.38
Sanding, 3 passes (60/80/100 grit)	BF@.023	SF	.08	.80	.88
2 coats of stain/sealer	BF@.010	SF	.12	.35	.47
2 coats of urethane	BF@.012	SF	.15	.42	.57
2 coats of lacquer	BF@.024	SF	.20	.83	1.03

Unfinished antique tongue and groove plank flooring 25/32" thick, random widths and lengths.

Includes typical cutting waste. Installed over a prepared subfloor.

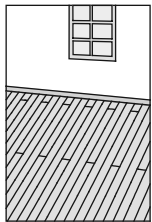

Ash, select, 3" to 7" wide	BF@.057	SF	5.75	1.97	7.72
Chestnut, American, 3" to 7" wide	BF@.057	SF	12.00	1.97	13.97
Chestnut, distressed, 3" to 7" wide	BF@.057	SF	14.10	1.97	16.07
Chestnut, distressed, over 7" wide	BF@.057	SF	18.40	1.97	20.37
Cherry, #1, 3" to 7" wide	BF@.057	SF	13.50	1.97	15.47
Cherry, #1, 6" wide and up	BF@.057	SF	16.30	1.97	18.27
Hickory, #1, 3" to 7" wide	BF@.057	SF	5.57	1.97	7.54
Hemlock, 3" to 7" wide	BF@.057	SF	9.61	1.97	11.58
Hemlock, over 7" wide	BF@.057	SF	12.60	1.97	14.57
Oak, #1, red or white, 3" to 7" wide	BF@.057	SF	5.12	1.97	7.09
Oak, #1, red or white, over 7" wide	BF@.057	SF	8.08	1.97	10.05
Oak, 3" to 7" wide	BF@.057	SF	10.20	1.97	12.17
Oak, over 7" wide	BF@.057	SF	12.40	1.97	14.37
Oak, distressed, 3" to 7" wide	BF@.057	SF	11.80	1.97	13.77
Oak, distressed, over 7" wide	BF@.057	SF	14.80	1.97	16.77
Maple, FAS, 3" to 7" wide	BF@.057	SF	7.06	1.97	9.03
Poplar, 3" to 8" wide	BF@.057	SF	4.97	1.97	6.94
Poplar, over 8" wide	BF@.057	SF	6.70	1.97	8.67
Walnut, #3, 3" to 7" wide	BF@.057	SF	8.08	1.97	10.05
White pine, 3" to 7"	BF@.057	SF	7.55	1.97	9.52
White pine, distressed, 3" to 7"	BF@.057	SF	8.22	1.97	10.19
White pine, distressed, over 7" wide	BF@.057	SF	11.90	1.97	13.87
White pine, knotty grade, 12" and up wide	BF@.057	SF	12.20	1.97	14.17
Yellow pine, 3" to 5" wide	BF@.057	SF	8.80	1.97	10.77
Yellow pine, 6" to 10" wide	BF@.057	SF	12.00	1.97	13.97

Unfinished northern hard maple strip flooring

25/32" x 2-1/4" (138.3 BF per 100 SF)

1st grade	BF@.036	SF	7.25	1.25	8.50
2nd grade	BF@.036	SF	6.49	1.25	7.74
3rd grade	BF@.036	SF	6.00	1.25	7.25

25/32" x 1-1/2" (155 BF per 100 SF)

1st grade	BF@.040	SF	8.65	1.38	10.03
2nd grade	BF@.040	SF	7.78	1.38	9.16
3rd grade	BF@.040	SF	7.17	1.38	8.55

Flooring, Wood Strip

	Craft@Hrs	Unit	Material	Labor	Total
33/32" x 1-1/2" (170 BF per 100 SF)					
1st grade	BF@.036	SF	8.06	1.25	9.31
2nd grade	BF@.036	SF	6.95	1.25	8.20
3rd grade	BF@.036	SF	6.53	1.25	7.78
Unfinished long plank flooring Random 3" to 5" widths, 1' to 16' lengths, 3/4" thick.					
Select grade, ash	BF@.062	SF	7.35	2.14	9.49
Common grade, cherry	BF@.062	SF	9.73	2.14	11.87
Select grade, cherry	BF@.062	SF	12.20	2.14	14.34
Select grade, rock maple	BF@.062	SF	9.12	2.14	11.26
Select grade, figured maple	BF@.062	SF	15.70	2.14	17.84
Select grade, red oak	BF@.062	SF	10.20	2.14	12.34
Select grade, white oak	BF@.062	SF	8.44	2.14	10.58
Unfinished wide plank flooring Random 6" to 8" widths, 1' to 16' lengths, 3/4" thick, including 8% waste, Specialty Wood Floors.					
Knotty grade, pine	BF@.074	SF	5.73	2.56	8.29
Select grade, cherry	BF@.074	SF	13.50	2.56	16.06
Select grade, maple	BF@.074	SF	12.30	2.56	14.86
Select grade, red oak	BF@.074	SF	11.40	2.56	13.96
Select grade, white oak	BF@.074	SF	10.30	2.56	12.86
Softwood flooring Material costs include typical waste and coverage loss. Estimates for sanding and finishing appear at the end of this section.					
Unfinished Douglas fir, C Grade and better, dry, vertical grain flooring. 1.25 board feet cover 1 square foot including end cutting and typical waste.					
1" x 2", square edge	BF@.037	SF	3.95	1.28	5.23
1" x 3", square edge	BF@.037	SF	3.98	1.28	5.26
1" x 4", tongue and groove	BF@.037	SF	3.23	1.28	4.51
Deduct for D Grade	—	SF	-.78	—	-.78
Add for B Grade and better	—	SF	.95	—	.95
Add for specific lengths	—	SF	.19	—	.19
Add for diagonal patterns	BF@.004	SF	—	.14	.14
Unfinished select kiln dried heart pine flooring, 97% dense heartwood, random lengths, including 5% waste. 1" to 1-1/4" thick.					
4" wide	BF@.042	SF	9.69	1.45	11.14
5" wide	BF@.042	SF	9.97	1.45	11.42
6" wide	BF@.042	SF	10.10	1.45	11.55
8" wide	BF@.046	SF	10.80	1.59	12.39
10" wide	BF@.046	SF	12.50	1.59	14.09
Add for diagonal patterns	BF@.004	SF	—	.14	.14
Unfinished plank flooring, 3/4" thick, 3" to 8" widths, 2' to 12' lengths.					
Antique white pine	BF@.100	SF	10.40	3.46	13.86
Antique yellow pine	BF@.100	SF	9.56	3.46	13.02
Milled heart pine	BF@.100	SF	11.30	3.46	14.76
Distressed oak	BF@.100	SF	12.30	3.46	15.76
Milled oak	BF@.100	SF	11.20	3.46	14.66
Distressed American chestnut	BF@.100	SF	11.40	3.46	14.86
Milled American chestnut	BF@.100	SF	12.30	3.46	15.76
Aged hemlock/fir	BF@.100	SF	11.40	3.46	14.86
Antique poplar	BF@.100	SF	5.22	3.46	8.68
Aged cypress	BF@.100	SF	6.21	3.46	9.67
Add for 9" to 15" widths	—	%	15.0	—	—
Add for sanding and finishing.					
Sanding, 3 passes (60/80/100 grit)	BF@.023	SF	.08	.80	.88
2 coats of stain/sealer	BF@.010	SF	.12	.35	.47
2 coats of urethane	BF@.012	SF	.15	.42	.57
2 coats of lacquer	BF@.024	SF	.20	.83	1.03

Flooring, Wood Strip, Prefinished

Craft@Hrs Unit Material Labor Total

Prefinished strip flooring

Tongue and groove, 25/32" thick, 2-1/4" wide. Includes typical cutting waste. Installed over a prepared subfloor

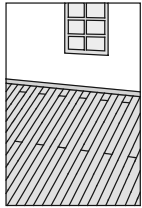

Honey wheat oak, case covers 18.1 SF	BF@.062	SF	3.96	2.14	6.10
Marsh oak, case covers 20 SF	BF@.062	SF	4.28	2.14	6.42
Gunstock oak, case covers 20 SF	BF@.062	SF	3.85	2.14	5.99
Autumn wheat hickory, case covers 22 SF	BF@.062	SF	5.89	2.14	8.03
Natural hickory, case covers 22 SF	BF@.062	SF	6.03	2.14	8.17
Tawny oak, case covers 18.25 SF	BF@.062	SF	6.21	2.14	8.35
Fawn oak, case covers 24 SF	BF@.062	SF	6.90	2.14	9.04
Prefinished oak strip flooring trim					
7' 10" quarter round	BF@.320	Ea	27.50	11.10	38.60
6' 6" reducer	BF@.531	Ea	41.80	18.40	60.20
6' 6" stair nose	BF@.531	Ea	37.50	18.40	55.90
6' 6" T-molding	BF@.531	Ea	59.90	18.40	78.30

Floating hardwood flooring Tongue and groove. Install over concrete or other subfloor using an underfloor membrane. Edges and ends glued. Based on 3/8" gap at walls covered with 1/2" base or quarter round molding. The labor estimates below include laying the membrane, hardwood flooring and gluing.

Poly foam membrane, 100 SF roll	—	SF	.34	—	.34
'Floor Muffler' poly foam, 100 SF roll	—	SF	.76	—	.76
Cork underlayment, 1/4", 200 SF roll	—	SF	.70	—	.70
Urethane adhesive, 150 SF per gallon	—	SF	.35	—	.35
1/2" tongue and groove hardwood flooring, various colors	FL@.051	SF	4.68	2.65	7.33

Laminate wood floor, Pergo Plastic laminate on pressed wood base, 7-7/8" x 47-1/4" x 3/8" (20 cm x 120 cm x 8 mm), loose lay with glued tongue and groove joints. Many wood finishes available. 20.67 SF (1.9 square meters) per pack. Includes 10% waste and joint glue (bottle covers 150 SF).

Pergo Presto, on floors					
Most finishes	BF@.051	SF	2.99	1.76	4.75
Glued on stairs (treads and risers)	BF@.115	SF	3.89	3.98	7.87
Add for FloorMuffler underlay (100 SF per pack)					
Pergo sound block foam	BF@.010	SF	.70	.35	1.05
Add for 8 mil poly vapor barrier (over concrete)	BF@.002	SF	.42	.07	.49
4-in1 molding; T-mold, reducer, end mold	BF@.002	SF	.17	.07	.24
4-in1 molding; T-mold, reducer, end mold	BF@.040	LF	5.03	1.38	6.41
Wall base, 4" high	BF@.040	LF	2.61	1.38	3.99
Stair nosing	BF@.050	LF	5.67	1.73	7.40

Laminate wood floor, Dupont Plastic laminate on pressed wood base, 11-1/2" x 46-9/16" x .0462", foam back, tongue and groove joints. Pack covers 17 SF with 8% waste.

Dupont Real Touch Elite on floors					
Most finishes	BF@.051	SF	5.48	1.76	7.24
Glued on stairs (treads and risers)	BF@.115	SF	7.01	3.98	10.99
6 mil vapor barrier (over concrete)	BF@.002	SF	.17	.07	.24

Bamboo flooring

Laminated plank bamboo flooring, tongue and groove, 72" long panels. Treated and kiln dried. Installs over wood subfloor. Use 1/2" nail gun. Space fasteners 8" to 10" apart, with a minimum of two nails per board. Assorted shades and textures.

5/8" x 3-3/4" prefinished	BF@.062	SF	5.01	2.14	7.15
1/2" x 3" unfinished	BF@.062	SF	5.01	2.14	7.15
Laminated bamboo baseboard					
3" beveled edge prefinished	BC@.040	LF	4.89	1.51	6.40

Flooring, Wood, Parquet

	Craft@Hrs	Unit	Material	Labor	Total
Laminated prefinished bamboo stair nose 1/2" x 3-1/4"	BC@.040	LF	7.52	1.51	9.03
Laminated prefinished bamboo threshold 9/16" x 3-5/8" flat grain	BC@.174	LF	5.76	6.55	12.31
9/16" x 3-5/8" edge grain	BC@.174	LF	5.82	6.55	12.37
5/8" x 2"	BC@.174	LF	7.52	6.55	14.07
Add for sanding and finishing					
Sanding, 3 passes (60/80/100 grit)	BF@.023	SF	.08	.80	.88
2 coats of stain/sealer	BF@.010	SF	.12	.35	.47
2 coats of urethane	BF@.012	SF	.15	.42	.57
2 coats of lacquer	BF@.024	SF	.20	.83	1.03

Parquet block flooring Includes typical waste and coverage loss, installed over a prepared subfloor.

Unfinished parquet block flooring, 3/4" thick, 10" x 10" to 39" x 39" blocks, includes 5% waste. Cost varies by pattern with larger blocks costing more. These are material costs only. Add labor cost below.

Ash or quartered oak, select	—	SF	22.30	—	22.30
Ash or quartered oak, natural	—	SF	16.30	—	16.30
Cherry or walnut select grade	—	SF	25.00	—	25.00
Cherry or walnut natural grade	—	SF	18.80	—	18.80
Oak, select plain	—	SF	18.10	—	18.10
Oak, natural plain	—	SF	15.60	—	15.60

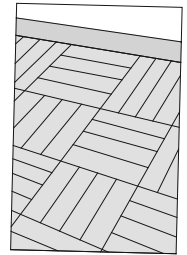

Prefinished parquet block flooring, 5/16" thick, select grade, specified sizes, includes 5% waste. Cost varies by pattern and size, with larger blocks costing more. These are material costs only. Add labor cost below.

Cherry or walnut					
9" x 9"	—	SF	6.93	—	6.93
13" x 13"	—	SF	8.23	—	8.23
Oak					
12" x 12" chestnut	—	SF	4.89	—	4.89
12" x 12" desert	—	SF	4.89	—	4.89
Teak					
12" x 12"	—	SF	6.21	—	6.21
Prefinished natural hardwood, commodity grade					
12" x 12"	—	SF	4.01	—	4.01

Labor and mastic for installing parquet block flooring

Parquet laid in mastic	BF@.055	SF	.33	1.90	2.23
Edge-glued over high density foam	BF@.052	SF	.54	1.80	2.34
Custom or irregular-shaped tiles, with adhesive	BF@.074	SF	.54	2.56	3.10
Add for installations under 1,000 SF	BF@.025	SF	.05	.86	.91
Add for sanding and finishing for unfinished parquet block flooring					
Sanding, 3 passes (60/80/100 grit)	BF@.023	SF	.08	.80	.88
2 coats of stain/sealer	BF@.010	SF	.12	.35	.47
2 coats of urethane	BF@.012	SF	.15	.42	.57
2 coats of lacquer	BF@.024	SF	.20	.83	1.03

Prefinished cross-band 3-ply birch parquet flooring, 6" to 12" wide by 12" to 48" blocks, Oregon Lumber.

Costs include cutting, fitting and 5% waste, but no subfloor preparation.

"Saima", 9/16" thick, typical price	BF@.050	SF	5.45	1.73	7.18
-------------------------------------	---------	----	------	------	------

Bonded blocks, 12" x 12", 1/8" thick, laid in mastic

Vinyl bonded cork	BF@.050	SF	4.46	1.73	6.19
Vinyl bonded domestic woods	BF@.062	SF	8.91	2.14	11.05
Vinyl bonded exotic woods	BF@.062	SF	18.10	2.14	20.24

Foundation Bolts

	Craft@Hrs	Unit	Material	Labor	Total
Acrylic (Permagrain) impregnated wood flooring. 12" x 12" x 5/16" thick block laid in mastic					
Oak block	BF@.057	SF	12.40	1.97	14.37
Ash block	BF@.057	SF	13.00	1.97	14.97
Cherry block	BF@.057	SF	13.50	1.97	15.47
Maple block	BF@.057	SF	13.90	1.97	15.87
Acrylic (Permagrain) impregnated 2-7/8" x random length plank laid in mastic					
Oak plank	BF@.057	SF	10.20	1.97	12.17
Maple plank	BF@.057	SF	13.70	1.97	15.67
Tupelo plank	BF@.057	SF	12.40	1.97	14.37
Lindenwood plank	BF@.057	SF	13.70	1.97	15.67
Cherry plank	BF@.057	SF	13.50	1.97	15.47
Wood flooring adhesive. For laminated wood plank and wood parquet flooring. Covers 150 square feet per gallon when applied with a 1/8" x 1/8" x 1/8" square-notch trowel for parquet or a 1/4" x 1/4" x 1/4" V-notch trowel for laminated plank.					
Quart	—	Ea	12.40	—	12.40
4 gallons	—	Ea	198.00	—	198.00

Foundation Bolts Galvanized, with nut and washer attached. Costs per bolt or bag.

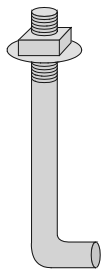

1/2" x 6", pack of 1	B1@.107	Ea	1.94	3.65	5.59
1/2" x 6", pack of 25	B1@5.35	Ea	32.20	182.00	214.20
1/2" x 8", pack of 1	B1@.107	Ea	2.30	3.65	5.95
1/2" x 8", pack of 25	B1@5.35	Ea	40.40	182.00	222.40
1/2" x 10", pack of 1	B1@.107	Ea	2.66	3.65	6.31
1/2" x 10", pack of 25	B1@5.35	Ea	47.50	182.00	229.50
1/2" x 12", pack of 1	B1@.107	Ea	3.27	3.65	6.92
1/2" x 12", pack of 25	B1@5.35	Ea	58.00	182.00	240.00
1/2" x 18", pack of 1	B1@.107	Ea	4.60	3.65	8.25
1/2" x 18", pack of 25	B1@5.35	Ea	82.20	182.00	264.20
5/8" x 8", pack of 1	B1@.107	Ea	4.52	3.65	8.17
5/8" x 8", pack of 10	B1@2.68	Ea	35.00	91.40	126.40
5/8" x 10", pack of 1	B1@.107	Ea	5.06	3.65	8.71
5/8" x 10", pack of 10	B1@2.68	Ea	37.90	91.40	129.30

Framing Connectors All bolted connectors include nuts, bolts, and washers as needed. Costs are based on bulk purchases. Add 20% for smaller quantities.

Equivalent Simpson Strong-Tie Co. model numbers are shown in parentheses.

Angle clips (A34 and A35), 18 gauge, galvanized, no nails included

3" x 5" connector (A35 or A35F)	BC@.030	Ea	.48	1.13	1.61
3" x 4" connector (A34)	BC@.030	Ea	.96	1.13	2.09

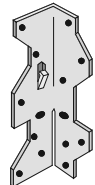

Angle clips ("L") for general utility use, 16 gauge, galvanized, no nails included

3" (L30)	BC@.027	Ea	1.04	1.02	2.06
5" (L50)	BC@.027	Ea	1.61	1.02	2.63
7" (L70)	BC@.027	Ea	2.33	1.02	3.35
9" (L90)	BC@.027	Ea	2.88	1.02	3.90

Brick wall ties (BTR), 22 gauge, per 1,000

7/8" x 6", corrugated	—	M	188.00	—	188.00
-----------------------	---	---	--------	---	--------

Bridging. See also Carpentry.

Cross or Tension bridging for solid sawn lumber (NCA & TB), steel, use in pair, no nails required

12" joist spacing on center					
2" x 8" joists (NCA2X8-12)	BC@.022	Pr	2.08	.83	2.91
2" x 10" joists (NCA2X10-12)	BC@.022	Pr	2.08	.83	2.91
2" x 12" joists (NCA2X12-12)	BC@.022	Pr	2.27	.83	3.10
2" x 14" joists (NCA2X8-16)	BC@.022	Pr	2.47	.83	3.30
2" x 16" joists (NCA2X10-16)	BC@.022	Pr	2.47	.83	3.30

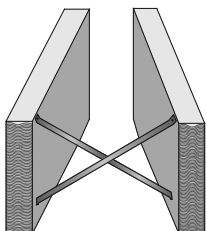

Framing Connectors

	Craft@Hrs	Unit	Material	Labor	Total
16" joist spacing on center					
2" x 8" joists (NCA2X8-16)	BC@.022	Pr	2.47	.83	3.30
2" x 10" joists (NCA2X10-16)	BC@.022	Pr	2.47	.83	3.30
2" x 12" joists (NCA2X12-16)	BC@.022	Pr	2.27	.83	3.10
2" x 14" to 2" x 16" joists (TB27)	BC@.022	Pr	4.61	.83	5.44
24" joist spacing on center					
2" x 10" to 2" x 16" joists (TB36)	BC@.022	Pr	6.42	.83	7.25
Cross or Tension bridging for I-Joists (TB), steel, per pair, no nails required					
12" joist spacing on center					
Joist heights 9-1/2" to 12" (TB20)	BC@.022	Pr	4.06	.83	4.89
Joist heights 14" to 18" (TB27)	BC@.022	Pr	4.61	.83	5.44
Joist heights 20" to 22" (TB30)	BC@.022	Pr	5.16	.83	5.99
Joist heights 24" to 30" (TB36)	BC@.022	Pr	6.42	.83	7.25
Joist height 32" (TB42)	BC@.022	Pr	7.54	.83	8.37
16" joist spacing on center					
Joist heights 9-1/2" to 16" (TB27)	BC@.022	Pr	4.61	.83	5.44
Joist heights 18" to 20" (TB30)	BC@.022	Pr	5.16	.83	5.99
Joist heights 22" to 28" (TB36)	BC@.022	Pr	6.42	.83	7.25
Joist heights 30" to 32" (TB42)	BC@.022	Pr	7.54	.83	8.37
24" joist spacing on center					
Joist heights 9-1/2" to 12" (TB30)	BC@.022	Pr	5.16	.83	5.99
Joist heights 14" to 22" (TB36)	BC@.022	Pr	6.42	.83	7.25
Joist heights 24" to 32" (TB42)	BC@.022	Pr	7.54	.83	8.37
Column bases, heavy duty (CB). Includes nuts and bolts. Labor shown is for placing column base before pouring concrete					
4" x 4" (CB44)	BC@.121	Ea	23.10	4.56	27.66
4" x 6" (CB46)	BC@.121	Ea	25.90	4.56	30.46
4" x 8" (CB48)	BC@.121	Ea	34.30	4.56	38.86
6" x 6" (CB66)	BC@.121	Ea	36.60	4.56	41.16
6" x 8" (CB68)	BC@.121	Ea	45.30	4.56	49.86
6" x 10" (CB610)	BC@.131	Ea	44.80	4.93	49.73
6" x 12" (CB612)	BC@.131	Ea	48.50	4.93	53.43
8" x 8" (CB88)	BC@.131	Ea	67.90	4.93	72.83
8" x 10" (CB810)	BC@.131	Ea	98.00	4.93	102.93
8" x 12" (CB812)	BC@.150	Ea	106.00	5.65	111.65
10" x 10" (CB1010)	BC@.150	Ea	127.00	5.65	132.65
10" x 12" (CB1012)	BC@.150	Ea	125.00	5.65	130.65
12" x 12" (CB1212)	BC@.150	Ea	139.00	5.65	144.65
Column caps or end column caps, heavy duty (CC) or (ECC). Includes nuts and bolts					
Column caps for solid lumber					
Beam size x post size					
4" x 4" (CC44)	BC@.260	Ea	54.00	9.79	63.79
4" x 6" (CC46)	BC@.300	Ea	87.70	11.30	99.00
6" x 4" (CC64)	BC@.300	Ea	118.00	11.30	129.30
6" x 6" (CC66)	BC@.400	Ea	93.40	15.10	108.50
6" x 8" (CC68)	BC@.600	Ea	118.00	22.60	140.60
8" x 6" (CC86)	BC@.600	Ea	130.00	22.60	152.60
8" x 8" (CC88)	BC@.750	Ea	130.00	28.20	158.20
10" x 6" (CC10X)	BC@.750	Ea	193.00	28.20	221.20
Column caps for glu-lam beams					
Beam size x post size					
3-1/4" x 4" (CC3-14-4)	BC@.260	Ea	108.00	9.79	117.79
3-1/4" x 6" (CC3-14-6)	BC@.300	Ea	105.00	11.30	116.30
5-1/4" x 6" (CC5-14-6)	BC@.400	Ea	136.00	15.10	151.10
5-1/4" x 8" (CC5-14-8)	BC@.600	Ea	132.00	22.60	154.60
7" x 6" (CC76)	BC@.600	Ea	132.00	22.60	154.60

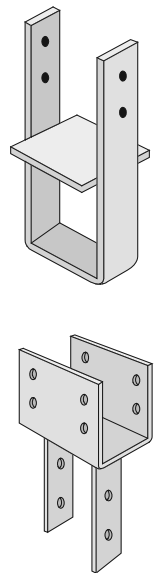

Framing Connectors

	Craft@Hrs	Unit	Material	Labor	Total
7" x 7" (CC77)	BC@.750	Ea	132.00	28.20	160.20
7" x 8" (CC78)	BC@.750	Ea	132.00	28.20	160.20
9" x 6" (CC96)	BC@.750	Ea	148.00	28.20	176.20
9" x 8" (CC98)	BC@.750	Ea	148.00	28.20	176.20
Floor tie anchors (FTA)					
2" x 38" (FTA2)	BC@.200	Ea	84.70	7.53	92.23
3-1/2" x 45" (FTA5)	BC@.200	Ea	116.00	7.53	123.53
3-1/2" x 56" (FTA7)	BC@.320	Ea	205.00	12.10	217.10
Header hangers (HH), 16 gauge, galvanized					
4" header (HH4)	BC@.046	Ea	8.00	1.73	9.73
6" header (HH6)	BC@.046	Ea	16.50	1.73	18.23
Hold downs (HD), including typical nuts, bolts and washers for studs. Add for foundation bolts					
HD2A	BC@.310	Ea	9.15	11.70	20.85
HD5A	BC@.310	Ea	24.00	11.70	35.70
HD8A	BC@.420	Ea	30.60	15.80	46.40
HD10A	BC@.500	Ea	35.10	18.80	53.90
HD20A	BC@.500	Ea	64.30	18.80	83.10
Threaded rod (ATR) 24" long. Labor includes drilling through 6" of wood					
1/2" rod, 12" length	BC@.185	LF	1.90	6.97	8.87
5/8" rod	BC@.185	LF	3.67	6.97	10.64
3/4" rod	BC@.200	LF	15.80	7.53	23.33
1" rod	BC@.220	LF	12.70	8.29	20.99
Hurricane and seismic ties (H)					
H1 tie	BC@.035	Ea	.90	1.32	2.22
H2 tie	BC@.027	Ea	2.02	1.02	3.04
H2.5 tie	BC@.027	Ea	.34	1.02	1.36
H3 tie	BC@.027	Ea	.46	1.02	1.48
H4 tie	BC@.027	Ea	.42	1.02	1.44
H5 tie	BC@.027	Ea	.69	1.02	1.71
H6 tie	BC@.045	Ea	5.23	1.69	6.92
H7Z tie	BC@.055	Ea	11.50	2.07	13.57
Mud sill anchors (MA)					
2" x 4" (MA4)	BC@.046	Ea	2.89	1.73	4.62
2" x 6" (MA6)	BC@.046	Ea	3.34	1.73	5.07
Panelized plywood roof hangers (F24N, F26N), for panelized plywood roof construction					
2" x 4" (F24N)	—	Ea	1.16	—	1.16
2" x 6" (F26N)	—	Ea	1.95	—	1.95
Purlin hangers (HU), without nails, 7 gauge					
4" x 4" (HU44)	BC@.052	Ea	8.89	1.96	10.85
4" x 6" (HU46)	BC@.052	Ea	10.80	1.96	12.76
4" x 8" (HU48)	BC@.052	Ea	12.10	1.96	14.06
4" x 10" (HU410)	BC@.070	Ea	12.40	2.64	15.04
4" x 12" (HU412)	BC@.070	Ea	17.00	2.64	19.64
4" x 14" (HU414)	BC@.087	Ea	23.10	3.28	26.38
4" x 16" (HU416)	BC@.087	Ea	26.60	3.28	29.88
6" x 6" (HU66)	BC@.052	Ea	17.60	1.96	19.56
6" x 8" (HU68)	BC@.070	Ea	16.00	2.64	18.64
6" x 10" (HU610)	BC@.087	Ea	26.20	3.28	29.48
6" x 12" (HU612)	BC@.087	Ea	30.80	3.28	34.08
6" x 16" (HU616)	BC@.117	Ea	52.10	4.41	56.51
8" x 10" (HU810)	BC@.087	Ea	29.50	3.28	32.78
8" x 12" (HU812)	BC@.117	Ea	33.10	4.41	37.51
8" x 14" (HU814)	BC@.117	Ea	44.80	4.41	49.21
8" x 16" (HU816)	BC@.117	Ea	54.40	4.41	58.81

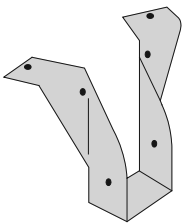
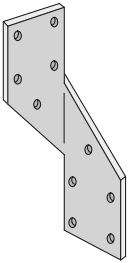
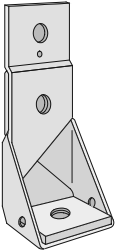

Framing Connectors

	Craft@Hrs	Unit	Material	Labor	Total
Top flange hangers (LB)					
2" x 6" (LB26)	BC@.046	Ea	4.27	1.73	6.00
2" x 8" (LB28)	BC@.046	Ea	4.63	1.73	6.36
2" x 10" (LB210)	BC@.046	Ea	6.54	1.73	8.27
2" x 12" (LB212)	BC@.046	Ea	16.50	1.73	18.23
2" x 14" (LB214)	BC@.052	Ea	11.40	1.96	13.36
Top flange hangers, heavy (HW)					
4" x 6" (HW46)	BC@.052	Ea	48.10	1.96	50.06
4" x 8" (HW48)	BC@.052	Ea	51.70	1.96	53.66
4" x 10" (HW410)	BC@.070	Ea	55.20	2.64	57.84
4" x 12" (HW412)	BC@.070	Ea	58.80	2.64	61.44
4" x 14" (HW414)	BC@.087	Ea	62.30	3.28	65.58
4" x 16" (HW416)	BC@.087	Ea	65.90	3.28	69.18
6" x 6" (HW66)	BC@.052	Ea	48.70	1.96	50.66
6" x 8" (HW68)	BC@.070	Ea	52.30	2.64	54.94
6" x 10" (HW610)	BC@.087	Ea	55.80	3.28	59.08
6" x 12" (HW612)	BC@.087	Ea	59.40	3.28	62.68
6" x 14" (HW614)	BC@.117	Ea	62.90	4.41	67.31
6" x 16" (HW616)	BC@.117	Ea	66.50	4.41	70.91
8" x 6" (HW86)	BC@.070	Ea	52.80	2.64	55.44
8" x 8" (HW88)	BC@.070	Ea	56.40	2.64	59.04
8" x 10" (HW810)	BC@.087	Ea	60.00	3.28	63.28
8" x 12" (HW812)	BC@.117	Ea	63.50	4.41	67.91
8" x 14" (HW814)	BC@.117	Ea	67.10	4.41	71.51
8" x 16" (HW816)	BC@.117	Ea	70.60	4.41	75.01
"U"-type or formed seat type hangers ("U"). Standard duty, 16 gauge, galvanized					
2" x 4" (U24)	BC@.040	Ea	1.69	1.51	3.20
2" x 6" (U26)	BC@.046	Ea	2.48	1.73	4.21
2" x 10" (U210)	BC@.046	Ea	3.39	1.73	5.12
2" x 14" (U214)	BC@.052	Ea	6.05	1.96	8.01
3" x 4" (U34)	BC@.046	Ea	5.04	1.73	6.77
3" x 6" (U36)	BC@.046	Ea	5.27	1.73	7.00
3" x 10" (U310)	BC@.052	Ea	5.58	1.96	7.54
3" x 14" (U314) or 3" x 16" (U316)	BC@.070	Ea	9.56	2.64	12.20
4" x 4" (U44)	BC@.046	Ea	4.15	1.73	5.88
4" x 6" (U46)	BC@.052	Ea	4.61	1.96	6.57
4" x 10" (U410)	BC@.070	Ea	5.90	2.64	8.54
4" x 14" (U414)	BC@.087	Ea	9.95	3.28	13.23
6" x 6" (U66)	BC@.052	Ea	13.30	1.96	15.26
6" x 10" (U610)	BC@.087	Ea	16.90	3.28	20.18
Plywood clips (PSCL, extruded aluminum, purchased in cartons of 500)					
3/8", 7/16", 1/2", or 5/8"	BC@.006	Ea	.13	.23	.36
Post base for decks (base with standoff, PBS), 12 gauge, galvanized					
4" x 4" (PBS44)	BC@.046	Ea	18.30	1.73	20.03
4" x 6" (PBS46)	BC@.046	Ea	19.20	1.73	20.93
6" x 6" (PBS66)	BC@.070	Ea	29.10	2.64	31.74
Add for rough lumber sizes	—	%	95.0	—	—
Post base (AB), adjustable, 16 gauge, galvanized					
4" x 4" (AB44B)	BC@.046	Ea	13.00	1.73	14.73
4" x 6" (AB46)	BC@.046	Ea	24.30	1.73	26.03
6" x 6" (AB66)	BC@.070	Ea	29.40	2.64	32.04
Add for rough lumber sizes	—	%	76.0	—	—
Post bases (PB), 12 gauge, galvanized					
4" x 4" (PB44)	BC@.046	Ea	9.39	1.73	11.12
4" x 6" (PB46)	BC@.046	Ea	13.00	1.73	14.73
6" x 6" (PB66)	BC@.070	Ea	18.70	2.64	21.34

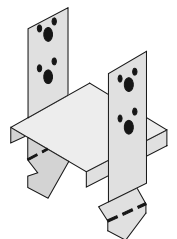
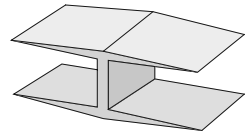
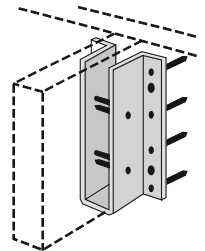

Framing Connectors

	Craft@Hrs	Unit	Material	Labor	Total
Post cap and base combination (BC), 18 gauge, galvanized					
4" x 4" (BC4)	BC@.037	Ea	5.76	1.39	7.15
4" x 6" (BC46)	BC@.037	Ea	7.35	1.39	8.74
6" x 6" (BC6)	BC@.054	Ea	16.60	2.03	18.63
8" x 8" (BC8)	BC@.054	Ea	60.20	2.03	62.23
Post caps and end post caps (PC), 12 gauge, galvanized. Beam size x post size					
4" x 4" (PC44)	BC@.052	Ea	18.30	1.96	20.26
4" x 6" (PC46)	BC@.052	Ea	17.80	1.96	19.76
4" x 8" (PC48)	BC@.052	Ea	32.90	1.96	34.86
6" x 4" (PC64)	BC@.052	Ea	28.90	1.96	30.86
6" x 6" (PC66)	BC@.077	Ea	28.90	2.90	31.80
6" x 8" (PC68)	BC@.077	Ea	29.80	2.90	32.70
8" x 8" (PC88)	BC@.077	Ea	47.60	2.90	50.50
Post top tie or anchor (AC), 18 gauge, galvanized					
4" x 4" (AC4)	BC@.040	Ea	5.76	1.51	7.27
6" x 6" (AC6)	BC@.040	Ea	7.66	1.51	9.17
Purlin anchors (PA), 12 gauge, 2" wide					
18" anchor (PA18)	BC@.165	Ea	6.90	6.21	13.11
23" anchor (PA23)	BC@.165	Ea	8.96	6.21	15.17
28" anchor (PA28)	BC@.185	Ea	10.40	6.97	17.37
35" anchor (PA35)	BC@.185	Ea	14.70	6.97	21.67
Split-ring connectors					
2-5/8" ring	BC@.047	Ea	3.78	1.77	5.55
4" ring	BC@.054	Ea	7.19	2.03	9.22
"L"-straps, 12 gauge (L)					
5" x 5", 1" wide (55L)	BC@.132	Ea	2.22	4.97	7.19
6" x 6", 1-1/2" wide (66L)	BC@.132	Ea	3.66	4.97	8.63
8" x 8", 2" wide (88L)	BC@.132	Ea	6.78	4.97	11.75
12" x 12", 2" wide (1212L)	BC@.165	Ea	8.86	6.21	15.07
Add for heavy duty straps, 7 gauge	—	%	250.0	—	—
Long straps (MST), 12 gauge					
27" (MST27)	BC@.165	Ea	6.47	6.21	12.68
37" (MST37)	BC@.165	Ea	8.86	6.21	15.07
48" (MST48)	BC@.265	Ea	11.50	9.98	21.48
60" (MST60)	BC@.265	Ea	23.60	9.98	33.58
72" (MST72)	BC@.285	Ea	31.00	10.70	41.70
Plate and stud straps (FHA), galvanized, 1-1/2" wide, 16 gauge					
6" (FHA6)	BC@.100	Ea	.41	3.77	4.18
9" (FHA9)	BC@.132	Ea	.50	4.97	5.47
12" (FHA12)	BC@.132	Ea	.69	4.97	5.66
18" (FHA18)	BC@.132	Ea	.86	4.97	5.83
24" (FHA24)	BC@.165	Ea	1.14	6.21	7.35
32" (FHA30)	BC@.165	Ea	1.41	6.21	7.62
Tie straps (ST)					
2-1/16" x 9-5/16" 20 ga. (ST292)	BC@.132	Ea	1.52	4.97	6.49
3/4" x 16-5/16" 20 ga. (ST2115)	BC@.046	Ea	1.28	1.73	3.01
2-1/16" x 16-5/16" 20 ga. (ST2215)	BC@.132	Ea	2.05	4.97	7.02
2-1/16" x 23-5/16" 16 ga. (ST6224)	BC@.165	Ea	4.35	6.21	10.56
2-1/16" x 33-13/16" 14 ga. (ST6236)	BC@.165	Ea	5.60	6.21	11.81
"T"-straps, 14 gauge (T)					
6" x 6", 1-1/2" wide (66T)	BC@.132	Ea	3.79	4.97	8.76
12" x 8", 2" wide (128T)	BC@.132	Ea	8.37	4.97	13.34
12" x 12", 2" wide (1212T)	BC@.132	Ea	16.40	4.97	21.37
Add for heavy duty straps, 7 gauge	—	%	270.0	—	—

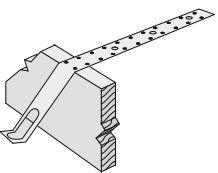
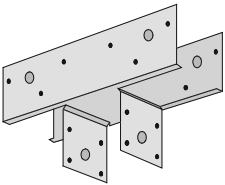
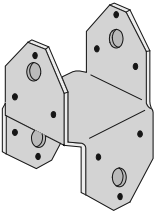

Garage Doors

	Craft@Hrs	Unit	Material	Labor	Total
Twist straps (TS), 16 gauge, galvanized, 1-1/4" wide					
9" (TS9)	BC@.132	Ea	3.23	4.97	8.20
11-5/8" (TS12)	BC@.132	Ea	1.07	4.97	6.04
17-3/4" (TS18)	BC@.132	Ea	1.82	4.97	6.79
21-5/8" (TS22)	BC@.165	Ea	4.12	6.21	10.33
Wall braces (WB), diagonal, 1-1/4" wide, 16 gauge					
10' long, corrugated or flat (WB106C or WB106)	BC@.101	Ea	12.60	3.80	16.40
12' long, flat (WB126)	BC@.101	Ea	14.40	3.80	18.20
14' long, flat (WB143C)	BC@.101	Ea	20.10	3.80	23.90
Wall braces (CWB), diagonal, 18 gauge, 1" wide					
10' long, L-shaped (CWB106)	BC@.125	Ea	14.50	4.71	19.21
12' long, L-shaped (CWB126)	BC@.125	Ea	17.00	4.71	21.71

Garage Door Openers Radio controlled, electric, single or double door, requires electrical outlet for plug-in connection, not included.

Security, chain drive, 1/2 HP	BC@3.90	Ea	128.00	147.00	275.00
Screw drive, 2 HP	BC@3.90	Ea	208.00	147.00	355.00
Security, belt drive, 3/4 HP	BC@3.90	Ea	198.00	147.00	345.00
Add for additional transmitter	—	Ea	29.90	—	29.90
Add for battery backup operator	—	Ea	128.00	—	128.00
Add for operator reinforcement kit	—	Ea	26.00	—	26.00
Add for low headroom kit	—	Ea	92.90	—	92.90
Add for emergency release	—	Ea	12.80	—	12.80
Belt rail extension kit	—	Ea	37.90	—	37.90
Chain glide extension kit	—	Ea	20.30	—	20.30
Chain rail extension kit	—	Ea	49.90	—	49.90
Screw drive extension kit	—	Ea	37.90	—	37.90

Garage Doors

Corrugated panel steel rollup door. Economy model, 26 gauge construction, installation hardware, no insulation.

8' x 7'	B1@6.46	Ea	490.00	220.00	710.00
9' x 7'	B1@6.46	Ea	527.00	220.00	747.00
10' x 7'	B1@8.33	Ea	600.00	284.00	884.00
Add for 8' height	—	%	10.5	—	—
Add for certified wind load	—	%	23.8	—	—

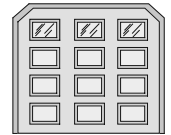

Corrugated panel steel rollup door. Heavy duty model, 26 gauge construction, installation hardware, no insulation.

8' x 7'	B1@4.46	Ea	775.00	152.00	927.00
9' x 7'	B1@5.46	Ea	834.00	186.00	1,020.00
10' x 7'	B1@6.46	Ea	859.00	220.00	1,079.00
12' x 7'	B1@7.46	Ea	1,030.00	254.00	1,284.00
16' x 7'	B1@8.33	Ea	1,160.00	284.00	1,444.00
Add for certified wind load	—	%	55.0	—	—
Add for Miami-Dade County code	—	%	105.0	—	—

Aluminum garage door. Uninsulated, 24 gauge woodgrain texture, side and bottom weatherstripping and hardware

8' x 7'	B1@6.46	Ea	1,110.00	220.00	1,330.00
9' x 7'	B1@6.46	Ea	1,170.00	220.00	1,390.00
16' x 7'	B1@8.33	Ea	1,410.00	284.00	1,694.00
Add for 8' height, single wide	B1@0.86	Ea	87.90	29.30	117.20
Add for 8' height, double wide	B1@1.16	Ea	117.00	39.60	156.60
Add for pilot door	—	Ea	820.00	—	820.00

Raised steel panel garage door. Uninsulated, 24 gauge woodgrain texture, bottom weatherstripping and hardware

8' x 7'	B1@6.46	Ea	1,520.00	220.00	1,740.00
9' x 7'	B1@6.46	Ea	1,640.00	220.00	1,860.00

Gates

	Craft@Hrs	Unit	Material	Labor	Total
16' x 7'	B1@8.33	Ea	1,870.00	284.00	2,154.00
Add for 8' height, single wide	B1@0.86	Ea	117.00	29.30	146.30
Add for 8' height, double wide	B1@1.16	Ea	146.00	39.60	185.60
Add for windows, single wide	—	Ea	234.00	—	234.00
Add for windows, double wide	—	Ea	322.00	—	322.00
Wood garage doors. 3/8" CDX paneling, unfinished, uninsulated, jamb hinges, and hardware.					
8' x 7'	B1@6.46	Ea	1,360.00	220.00	1,580.00
9' x 7'	B1@6.46	Ea	1,480.00	220.00	1,700.00
16' x 7'	B1@8.33	Ea	1,660.00	284.00	1,944.00
Add for 8' height, single wide	B1@0.86	Ea	114.00	29.30	143.30
Add for 8' height, double wide	B1@1.16	Ea	142.00	39.60	181.60
Add for 5/8" CDX paneling	—	%	10.8	—	—
Add for redwood or cedar 1" construction	—	%	287.0	—	—
Add for plant-on trim, pine, 1" x 6"	B1@.019	LF	5.62	.65	6.27
Add for plant-on trim, redwood or cedar, 1" x 6"	B1@.019	LF	9.37	.65	10.02
Add for windows, no grid	—	Ea	319.00	—	319.00
Add for windows, with grid	—	Ea	348.00	—	348.00
Sectional garage doors. Value series, 1-layer 25 gauge steel construction, bottom weatherstripping, and hardware.					
8' x 7'	B1@6.46	Ea	477.00	220.00	697.00
9' x 7'	B1@6.46	Ea	476.00	220.00	696.00
16' x 7'	B1@8.33	Ea	828.00	284.00	1,112.00
Add for plain windows	—	%	41.7	—	—
Sectional garage doors. Premium series, 3-layer 25 gauge steel construction, R-Value 18.4 insulation, bottom weatherstripping, and hardware.					
8' x 7'	B1@6.46	Ea	1,030.00	220.00	1,250.00
9' x 7'	B1@6.46	Ea	1,090.00	220.00	1,310.00
16' x 7'	B1@8.33	Ea	1,620.00	284.00	1,904.00
Add for plain windows	—	%	28.2	—	—
Sectional garage doors. Gallery series, 3-layer 25 gauge steel construction, R-Value 6.5 insulation, arch grill windows, stained wood-grained, bottom weatherstripping, and hardware.					
8' x 7'	B1@6.46	Ea	1,630.00	220.00	1,850.00
16' x 7'	B1@8.33	Ea	3,000.00	284.00	3,284.00
Garage door weather seal kit					
For 9' wide garage door	BC@.500	Ea	65.70	18.80	84.50
For garage door to 18' wide	BC@1.00	Ea	118.00	37.70	155.70
Garage door deadbolt lock with cylinder assembly					
Garage door lock	BC@.500	Ea	13.20	18.80	32.00
"T"-handle for rollup garage door bar lock					
Handle	BC@.250	Ea	9.15	9.42	18.57
Garage door hardware, jamb type, 7' height, with springs and slide bolt					
8' to 10' wide door	BC@4.36	Ea	163.00	164.00	327.00
10' to 16' wide door, with truss	BC@5.50	Ea	190.00	207.00	397.00
Truss assembly for 16' door	BC@.493	Ea	58.40	18.60	77.00
Garage door hardware, track type, 7' height, with springs and lock					
7' to 9' wide door	BC@4.36	Ea	325.00	164.00	489.00
10' to 16' double track	BC@5.50	Ea	562.00	207.00	769.00

Gates, Ornamental Aluminum, Swing, Automatic



Welded aluminum, black driveway swing gates, double swing, arched up or down. Labor costs assume connection, but no wire runs. 2" square frame, 2" x 1-1/2" horizontal rails and 1" square pickets. Post and brackets not included. Hoover Fence (Jerith Estate style 202, 4' to 5' high)



12' wide opening	BL@1.00	Ea	2,880.00	30.60	2,910.60
16' wide opening	BL@1.20	Ea	3,640.00	36.70	3,676.70
20' wide opening	BL@1.40	Ea	4,490.00	42.80	4,532.80
Add for custom width gates	—	%	20.0	—	—

Glass

	Craft@Hrs	Unit	Material	Labor	Total
Gate posts					
4" x 9' post	BL@1.00	Ea	139.00	30.60	169.60
6" x 12' post	BL@1.00	Ea	335.00	30.60	365.60
Add for setting post in concrete	BL@.330	Ea	3.50	10.10	13.60
12 volt DC swing gate operator	BL@5.00	Ea	730.00	153.00	883.00
Dual gate unit	BL@5.00	Ea	857.00	153.00	1,010.00
Add for additional gate transmitters	—	Ea	47.50	—	47.50
Add for low voltage wire	—	LF	.37	—	.37
Glass Material only. See labor costs below.					
Cut window glass, clear DSB glass (double strength, B Grade)					
8" x 10"	—	Ea	2.19	—	2.19
10" x 12"	—	Ea	2.97	—	2.97
11" x 14"	—	Ea	3.51	—	3.51
12" x 16"	—	Ea	4.47	—	4.47
12" x 36"	—	Ea	7.99	—	7.99
16" x 20"	—	Ea	6.23	—	6.23
18" x 36"	—	Ea	11.90	—	11.90
24" x 30"	—	Ea	13.30	—	13.30
24" x 36"	—	Ea	15.60	—	15.60
30" x 36"	—	Ea	19.90	—	19.90
36" x 48"	—	Ea	36.40	—	36.40
SSB glass (single strength, B Grade)					
To 60" width plus length	—	SF	2.68	—	2.68
Over 60" to 70" width plus length	—	SF	3.33	—	3.33
Over 70" to 80" width plus length	—	SF	2.97	—	2.97
DSB glass (double strength, B Grade)					
To 60" width plus length	—	SF	3.74	—	3.74
Over 60" to 70" width plus length	—	SF	3.81	—	3.81
Over 70" to 80" width plus length	—	SF	3.88	—	3.88
Over 80" to 100" width plus length	—	SF	4.15	—	4.15
Non-glare glass	—	SF	6.40	—	6.40
Float glass, 1/4" thick					
To 25 SF	—	SF	4.20	—	4.20
25 to 35 SF	—	SF	4.52	—	4.52
35 to 50 SF	—	SF	4.90	—	4.90
Insulating glass, clear					
1/2" thick, 1/4" airspace, up to 25 SF	—	SF	9.08	—	9.08
5/8" thick, 1/4" airspace, up to 35 SF	—	SF	10.60	—	10.60
1" thick, 1/2" airspace, up to 50 SF	—	SF	12.30	—	12.30
Tempered glass, clear, 1/4" thick					
To 25 SF	—	SF	9.08	—	9.08
25 to 50 SF	—	SF	10.90	—	10.90
50 to 75 SF	—	SF	11.90	—	11.90
Tempered glass, clear, 3/16" thick					
To 25 SF	—	SF	8.93	—	8.93
25 to 50 SF	—	SF	10.20	—	10.20
50 to 75 SF	—	SF	11.30	—	11.30
Laminated safety glass, 1/4" thick, ASI safety rating					
Up to 25 SF	—	SF	11.60	—	11.60
25 to 35 SF	—	SF	12.10	—	12.10
Polycarbonate sheet, .093" thick, clear					
8" x 10"	—	Ea	5.27	—	5.27
12" x 24"	—	Ea	16.80	—	16.80
18" x 24"	—	Ea	23.20	—	23.20
36" x 48"	—	Ea	91.40	—	91.40
36" x 72"	—	Ea	117.00	—	117.00

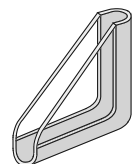

Greenhouses

	Craft@Hrs	Unit	Material	Labor	Total
Acrylic plastic sheet (Plexiglas), clear					
11" x 14" .093" thick	—	Ea	7.04	—	7.04
12" x 24" .093" thick	—	Ea	8.41	—	8.41
18" x 24" .093" thick	—	Ea	14.10	—	14.10
18" x 24" .22" thick	—	Ea	31.30	—	31.30
30" x 36" .093" thick	—	Ea	34.40	—	34.40
30" x 36" .22" thick	—	Ea	76.90	—	76.90
36" x 48" .093" thick	—	Ea	50.40	—	50.40
36" x 72" .093" thick	—	Ea	73.50	—	73.50
36" x 72" .22" thick	—	Ea	156.00	—	156.00
48" x 96" 1/8" thick	—	Ea	164.00	—	164.00
Beveled edge mirrors, no frame included	—	SF	11.20	—	11.20
Labor setting glass in wood or metal sash with vinyl bed					
To 15 SF, 1 hour charge	BG@1.77	LS	—	64.50	64.50
15 to 25 SF, 2 hour charge	BG@3.53	LS	—	129.00	129.00
25 to 35 SF, 3 hour charge	BG@5.30	LS	—	193.00	193.00
Labor to bevel edges, per linear inch					
1/2" beveled edge	BG@.013	Inch	—	.47	.47
1" beveled edge	BG@.063	Inch	—	2.30	2.30

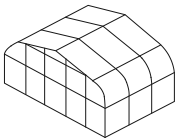
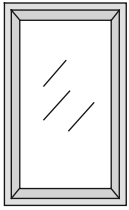

Greenhouses, Sun Porches, Spa Enclosures Freestanding or lean-to models. Anodized aluminum frame, acrylic glazed. Add the cost of excavation and concrete. Expect to see a wide variation in greenhouse costs for any given size.

Freestanding greenhouse enclosures, one door and four walls. 8' deep					
7' high, 6' wide	B1@21.0	Ea	5,860.00	716.00	6,576.00
7-1/2' high, 9' wide	B1@33.0	Ea	7,320.00	1,130.00	8,450.00
8' high, 12' wide	B1@47.0	Ea	8,510.00	1,600.00	10,110.00
8' high, 15' wide	B1@59.0	Ea	9,920.00	2,010.00	11,930.00
9' high, 18' wide	B1@80.0	Ea	11,200.00	2,730.00	13,930.00
Lean-to greenhouse enclosures attached on long dimension to an existing structure, one door and three walls. 8' deep					
7' high, 3' wide	B1@8.40	Ea	3,090.00	287.00	3,377.00
7' high, 6' wide	B1@16.8	Ea	4,630.00	573.00	5,203.00
7-1/2' high, 9' wide	B1@27.0	Ea	5,820.00	921.00	6,741.00
8' high, 12' wide	B1@38.4	Ea	7,060.00	1,310.00	8,370.00
8' high, 15' wide	B1@48.0	Ea	8,260.00	1,640.00	9,900.00
Add for additional outswing door	—	Ea	348.00	—	348.00
Add for additional sliding window	—	Ea	187.00	—	187.00

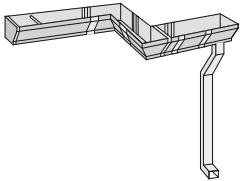

Gutters and Downspouts

Galvanized steel, 5" box type					
Gutter, 5", 10' lengths	SW@.070	LF	.95	2.98	3.93
Inside or outside miter corner	SW@.091	Ea	14.30	3.87	18.17
Fascia support brackets	—	Ea	4.55	—	4.55
Spike and ferrule support, 7"	—	Ea	1.40	—	1.40
Gutter slip-joint connector	—	Ea	5.27	—	5.27
End cap	—	Ea	3.30	—	3.30
Add per 2" x 3" downspout, with drop outlet, 3 ells, strainer, 2 bands and 15" extension					
10' downspout	SW@.540	Ea	71.10	23.00	94.10
20' downspout with coupling	SW@.810	Ea	92.50	34.40	126.90
Aluminum rain gutter, 5" box type, primed					
Gutter, 5", 10' lengths	SW@.070	LF	1.51	2.98	4.49
Inside or outside corner	SW@.091	Ea	7.79	3.87	11.66
Fascia support brackets	—	Ea	2.17	—	2.17
Gutter hanger and support	—	Ea	.56	—	.56
End cap	—	Ea	.86	—	.86

Gypsum Drywall and Accessories

	Craft@Hrs	Unit	Material	Labor	Total
Add per 2" x 3" downspout, with drop outlet, 3 ells, strainer, 2 bands and 15" extension					
10' downspout	SW@.540	Ea	43.60	23.00	66.60
20' downspout with coupling	SW@.810	Ea	56.90	34.40	91.30
	Unit	4' x 8'	4' x 9'	4' x 10'	4' x 12'
Gypsum Drywall and Accessories Labor costs are for good quality hanging and taping with smooth sanded joints (Level 4) and include 6% waste but no texturing. See texturing costs below. Installed costs include premixed joint compound, (5 gallons per 1,000 SF), 2" perforated joint tape (380 LF per 1,000 SF) and drywall screws (4-1/2 pounds per 1,000 SF) at the following material prices. Ea = 1 sheet					
Plain board					
1/4"	Ea	14.60	16.40	18.20	21.90
3/8"	Ea	14.40	16.30	18.10	21.70
1/2"	Ea	10.60	13.10	14.60	19.10
5/8" fire-rated	Ea	16.90	18.20	16.80	25.00
Lightweight board					
1/2"	Ea	15.10	16.10	15.80	19.10
5/8" fire-rated	Ea	15.40	18.40	18.90	24.30
Mold/moisture resistant board					
1/2"	Ea	19.30	21.00	22.90	27.40
5/8" fire-rated	Ea	20.30	21.50	23.30	27.70
Type 'C' & 'X' fire-rated					
1/2" Type 'C'	Ea	16.30	18.40	20.40	24.50
5/8" Type 'C'	Ea	17.10	19.20	21.40	25.60
5/8" Type 'X'	Ea	15.40	18.20	19.30	22.80
	Craft@Hrs	Unit	Material	Labor	Total
Drywall installation costs					
1/4" plain board Walls	D1@.016	SF	.46	.59	1.05
3/8" plain board Walls	D1@.017	SF	.45	.63	1.08
1/2" plain board Walls	D1@.018	SF	.45	.67	1.12
1/2" moisture-resistant green board Walls	D1@.018	SF	.58	.67	1.25
1/2" fire-rated mold-tough Walls	D1@.018	SF	.51	.67	1.18
5/8" fire-rated board Walls	D1@.020	SF	.49	.74	1.23
Add for 1/2" ceiling installation	—	%	—	33.3	—
Add for 5/8" ceiling installation	—	%	—	25.0	—
Add for level 5 drywall finishing, per 100 SF	D1@.088	CSF	2.17	3.26	5.43
Deduct for no taping or joint finishing					
Walls	—	CSF	-6.75	-72.80	-73.00
Ceilings	—	CSF	-6.75	-96.80	-97.00
Drywall finishing. Per ASTM C840. Higher 'level' figures include prior 'levels'.					
Add for tape embedding only, no joint finishing	DT@.115	CSF	1.46	4.29	5.75
Level 1 – taping and finishing wall joints (firetape)	DT@.219	CSF	3.65	8.16	11.81
Level 2 – finishing wall joints	DT@.388	CSF	5.01	14.50	19.51
Level 3 – finishing wall joints	DT@.519	CSF	6.37	19.30	25.67
Level 4 – finishing wall joints	DT@.625	CSF	6.75	23.30	30.05
Level 5 – finishing wall joints, skim entire surface	DT@.713	CSF	8.92	26.60	35.52
Level 5 –only, skim entire surface	DT@.080	CSF	2.17	2.98	5.15
Add for taping and finishing ceiling joints	—	%	—	33.3	—

Gypsum Drywall and Accessories

	Craft@Hrs	Unit	Material	Labor	Total
Drywall texture					
Light hand texture	DT@.500	CSF	.24	18.60	18.84
Medium hand texture	DT@.600	CSF	.34	22.40	22.74
Heavy hand texture	DT@.700	CSF	.56	26.10	26.66
Skim coat, smooth	DT@1.20	CSF	.21	44.70	44.91
Knockdown, spray applied and troweled	DT@.200	CSF	.29	7.45	7.74
Acoustic ceiling (popcorn), spray application					
Light coverage	DT@.800	CSF	1.67	29.80	31.47
Medium coverage	DT@1.10	CSF	2.34	41.00	43.34
Heavy coverage	DT@1.60	CSF	3.90	59.60	63.50
Glitter application to acoustic ceiling texture	DT@.200	CSF	1.38	7.45	8.83
Remove acoustic ceiling texture (no asbestos)	BL@1.13	CSF	—	34.50	34.50
Repair drywall "blow-out" patch					
Patch "blow-out"	D1@.333	Ea	2.49	12.30	14.79
Joint compounds					
All-purpose joint compound, premix, 4.5 gal	—	Ea	15.20	—	15.20
Lightweight joint finishing compound, 3.5 gal	—	Ea	13.20	—	13.20
Joint tapes					
Perforated joint tape, 500' roll	—	Ea	4.21	—	4.21
Self-adhesive fiberglass joint tape, 150' roll	—	Ea	7.46	—	7.46
Drywall screws, 5 pound box	—	Ea	21.00	—	21.00
Topping compounds, mix with water					
Wall and ceiling spray texture, 50 lb.	—	Ea	11.00	—	11.00
Wall and ceiling hand applied texture, 50 lb.	—	Ea	15.90	—	15.90
Drywall casing and channel trim.					
Stop or casing or jamb casing	D1@.020	LF	.33	.74	1.07
7/8" hat channel	D1@.011	LF	.49	.41	.90
Narrow soundproofing channel, metal	D1@.011	LF	.98	.41	1.39
Narrow soundproofing channel, PVC	D1@.011	LF	1.18	.41	1.59
Regular soundproofing channel, metal	D1@.011	LF	.98	.41	1.39
Regular soundproofing channel, w/ iso tape	D1@.011	LF	1.29	.41	1.70
RC-1 resilient hat channel	D1@.011	LF	.74	.41	1.15
RC-1 resilient hat channel, w/ iso tape	D1@.011	LF	1.11	.41	1.52
RC-2 resilient hat channel (for ceilings)	D1@.011	LF	.95	.41	1.36
RC-2 resilient hat channel w/ iso tape	D1@.011	LF	1.25	.41	1.66
Drywall arch and corner trim, metal					
Corner bead, 1-1/4"	D1@.030	LF	.36	1.11	1.47
Corner bullnose, 3/4" radius	D1@.030	LF	.64	1.11	1.75
Type "J" bead, 1/2" or 5/8"	D1@.030	LF	.37	1.11	1.48
Drywall arch and corner trim, vinyl					
Corner bead, 1-1/4"	D1@.030	LF	.27	1.11	1.38
Corner bead, flexible (arch) 1-1/4"	D1@.030	LF	.44	1.11	1.55
Corner bullnose, 3/4" radius	D1@.030	LF	.19	1.11	1.30
Corner bullnose, 3/4" radius, flexible (arch)	D1@.030	LF	.94	1.11	2.05
Type "J" bead, 1/2" or 5/8"	D1@.030	LF	.19	1.11	1.30
Bullnose corner, 2-way	D1@.160	Ea	1.48	5.93	7.41
Bullnose corner, 3-way	D1@.160	Ea	1.28	5.93	7.21
Corner guard, nail on, 3/4"	D1@.030	LF	.37	1.11	1.48
Corner guard, stick on, 3/4"	D1@.030	LF	.43	1.11	1.54

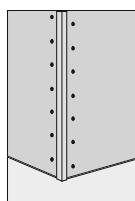

Hardware See also Bath Accessories, Door Chimes, Door Closers, Foundation Bolts, Garage Door Openers, Mailboxes, Nails, Screen Wire, Sheet Metal, Framing Connectors, and Weatherstripping.
 Rule of thumb: Cost of finish hardware (including door hardware, catches, stops, racks, brackets and pulls) per house.

Low to medium cost house (1,600 SF)	BC@16.0	LS	1,320.00	603.00	1,923.00
Better quality house (2,000 SF)	BC@20.0	LS	1,590.00	753.00	2,343.00

Hardware

	Craft@Hrs	Unit	Material	Labor	Total
Keyed entry locksets. Meets ANSI Grade 2 standards for residential security. One-piece knob. Triple option faceplate fits square, radius-round, and drive-in door preps.					
Antique brass	BC@.250	Ea	25.40	9.42	34.82
Antique pewter	BC@.250	Ea	28.50	9.42	37.92
Bright brass	BC@.250	Ea	25.40	9.42	34.82
Satin chrome	BC@.250	Ea	27.50	9.42	36.92
Lever locksets. Dual torque springs eliminate wobble.					
Antique brass	BC@.250	Ea	74.50	9.42	83.92
Polished brass	BC@.250	Ea	71.80	9.42	81.22
Egg knob entry locksets					
Satin nickel finish	BC@.250	Ea	34.60	9.42	44.02
Solid forged brass, polished brass finish	BC@.250	Ea	139.00	9.42	148.42
Colonial knob entry locksets					
Polished brass	BC@.250	Ea	126.00	9.42	135.42
Double cylinder high security lockset. Forged brass handle with thumb latch. Separate grade 1 security double cylinder deadbolt.					
Chrome finish	BC@.820	Ea	190.00	30.90	220.90
Construction keying system (minimum order of 20 keyed entry locks)					
Additional cost per lockset	—	Ea	6.67	—	6.67
Deadbolt and lockset combo. Includes keyed alike entry knob and grade 2 security deadbolt with 4 keys. Single cylinder.					
Polished brass finish	BC@.750	Ea	43.80	28.20	72.00
Mortise lockset and deadbolt. Steel reinforced cast 1" throw deadbolt. Solid brass latch. Rocker switch locks and unlocks exterior knob. Labor includes mortising of door.					
Left or right hand throw	BC@1.05	Ea	194.00	39.50	233.50
Deadbolts. All metal and brass. ANSI Grade 2 rating. 1" throw deadbolt. Includes 2 keys. Polished brass.					
Single cylinder	BC@.500	Ea	18.90	18.80	37.70
Double cylinder	BC@.500	Ea	45.80	18.80	64.60
Knob passage latch					
Dummy, brass	BC@.250	Ea	5.33	9.42	14.75
Dummy, satin nickel	BC@.250	Ea	6.98	9.42	16.40
Hall or closet, brass	BC@.250	Ea	9.23	9.42	18.65
Hall or closet, satin nickel	BC@.250	Ea	8.62	9.42	18.04
Egg knob privacy latchset					
Bright brass	BC@.250	Ea	22.10	9.42	31.52
Satin nickel	BC@.250	Ea	27.50	9.42	36.92
Privacy lever latchset. Both levers locked or unlocked by turn button. Outside lever can be unlocked by emergency key (included).					
Rubbed bronze	BC@.250	Ea	37.30	9.42	46.72
Polished brass	BC@.250	Ea	51.10	9.42	60.52
Satin nickel	BC@.250	Ea	29.50	9.42	38.92
Door knockers. Polished brass.					
Apartment type, brass, with viewer	BC@.250	Ea	6.61	9.42	16.03
4" x 8-1/2", ornate style	BC@.250	Ea	63.00	9.42	72.42
Door pull plates					
Brass finish, 4" x 16"	BC@.333	Ea	42.80	12.50	55.30
Door push plates					
Aluminum, 3" x 12"	BC@.333	Ea	11.90	12.50	24.40
Solid brass, 4" x 16"	BC@.333	Ea	12.80	12.50	25.30
Door kick plates					
6" x 30", brass	BC@.333	Ea	24.40	12.50	36.90
8" x 34", brass	BC@.333	Ea	25.50	12.50	38.00
8" x 34", magnetic, for metal door, brass	BC@.333	Ea	17.60	12.50	30.10
8" x 34", satin nickel	BC@.333	Ea	28.40	12.50	40.90
Floor mounted stop, satin nickel	BC@.333	Ea	5.38	12.50	17.88

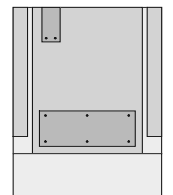
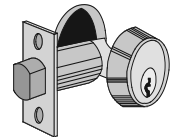

Hardware

Craft@Hrs Unit Material Labor Total

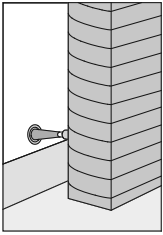

Door stops

Spring type wall bumper, 3" long	BC@.116	Ea	2.57	4.37	6.94
Wall bumper, 3" long, brass	BC@.116	Ea	4.87	4.37	9.24
Floor mounted stop, satin nickel	BC@.333	Ea	5.38	12.50	17.88
Hinge pin door stop, brass	BC@.250	Ea	2.63	9.42	12.05
Kick down door holder, brass	BC@.250	Ea	10.90	9.42	20.32
Magnetic wall stop	BC@.333	Ea	6.91	12.50	19.41
Adhesive rubber cup knob strike	BC@.116	Ea	5.44	4.37	9.81

Door peep sights

180-degree viewing angle	BC@.258	Ea	11.90	9.72	21.62
--------------------------	---------	----	-------	------	-------



Pocket door frame and track. Fully assembled. Designed to hold 150-pound standard 80" door. Door sold separately.

24" x 80"	BC@1.00	Ea	216.00	37.70	253.70
28" x 80"	BC@1.00	Ea	217.00	37.70	254.70
30" x 80"	BC@1.00	Ea	218.00	37.70	255.70
32" x 80"	BC@1.00	Ea	219.00	37.70	256.70
36" x 80"	BC@1.00	Ea	219.00	37.70	256.70

Pocket door edge pulls

Bronze passage pull, oil rubbed	BC@.300	Ea	29.20	11.30	40.50
Satin nickel privacy latch	BC@.300	Ea	21.10	11.30	32.40
Bronze privacy latch	BC@.300	Ea	17.30	11.30	28.60
Chrome privacy latch	BC@.300	Ea	15.70	11.30	27.00
Bronze passage pull	BC@.300	Ea	14.60	11.30	25.90
Oblong door pull	BC@.300	Ea	5.80	11.30	17.10

Ball bearing pocket door hangers

Hanger	BC@.175	Ea	14.80	6.59	21.39
--------	---------	----	-------	------	-------

Converging pocket door hardware kit. For double pocket doors.

Door kit	—	Ea	21.40	—	21.40
----------	---	----	-------	---	-------

Pocket door hangers

Pocket door hanger, 4-pack	BC@.175	Ea	9.35	6.59	15.94
1/16" offset, one wheel	BC@.175	Ea	13.10	6.59	19.69
7/8" offset, two wheel	BC@.175	Ea	9.57	6.59	16.16

Touch bar exit hardware. For use with 1-3/4"-thick hollow metal and wood doors. Extruded anodized aluminum with stainless steel spring. 3/4" throw stainless steel latch bolts. Strike for 5/8" stop; shim for 1/2" stop; 2-3/4" backset, 4-1/4" minimum stile. Includes standard mounting with sheet metal and machine screws. Recommended mounting height: 40-5/16" from ceiling to finished floor. 36" maximum width. Rim-type cylinders with Schlage "C" keyway. Includes measure and mark, drill holes, assemble, set strike plate.

Install, single door	BC@1.45	Ea	132.00	54.60	186.60
Install, per set of double doors	BC@2.97	Ea	264.00	112.00	376.00

Add for monitor switch for electrically operated locks

Per lock	—	Ea	79.40	—	79.40
----------	---	----	-------	---	-------

Electromagnetic security and life safety lock system. Surface mounted on door frame. Stainless steel finish. Includes magnet, strike plate, mounting fasteners and template. Costs include connection. Add for wire runs. Magnalock™.

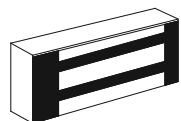

600 lb holding force 12/24 VDC	E4@2.00	Ea	326.00	103.00	429.00
1,200 lb holding force 12/24 VDC	E4@2.00	Ea	433.00	103.00	536.00
1,800 lb holding force 12/24 VDC	E4@2.00	Ea	453.00	103.00	556.00
Digital timer, 12/24 AC/DC	E4@.500	Ea	164.00	25.70	189.70
Exit delay timer, regulated DC voltage	E4@2.50	Ea	116.00	128.40	244.40

Heating, Hydronic

	Craft@Hrs	Unit	Material	Labor	Total
Exit delay system documentation and pressure sensitive vinyl door label for NFPA 101 requirements	—	Ea	15.40	—	15.40
Tamper-resistant plunger sex bolt	—	Ea	128.00	—	128.00
Energy absorbing sex bolt	—	Ea	248.00	—	248.00
Replacement strike plate and fasteners	—	Ea	114.00	—	114.00
Field mounted stainless steel housing. Includes cover, end caps, mounting plate and fasteners	BC@1.50	Ea	605.00	56.50	661.50
House street numbers, per number					
4" high, nail-on, aluminum	BC@.103	Ea	1.63	3.88	5.51
4" high, traditional brass	BC@.103	Ea	5.49	3.88	9.37
4" high, contemporary bronze	BC@.103	Ea	7.14	3.88	11.02
4" high, stainless steel	BC@.103	Ea	25.70	3.88	29.58
5" high, solid brass	BC@.103	Ea	8.25	3.88	12.13



Hinges

Full mortise hinge, heavy duty, satin brass finish					
3-1/2" x 3-1/2", 6 screws, .123 gauge	BC@.333	Ea	9.66	12.50	22.16
4" x 4", 8 screws, .130 gauge	BC@.333	Ea	13.20	12.50	25.70
4" x 4", spring hinge	BC@.333	Ea	19.00	12.50	31.50
Full mortise hinge, light duty, satin brass finish					
3-1/2" x 3-1/2", loose pin	BC@.333	Ea	3.55	12.50	16.05
4" x 4", loose pin	BC@.333	Ea	4.05	12.50	16.55
Screen door hinge kit, 2 hinges, door pull and hook					
Bright zinc	BC@.750	Ea	17.30	28.20	45.50

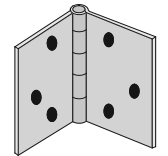

Hydronic Heating and Controls A complete system will consist of a hydronic boiler, cast iron radiators or hydronic radiation baseboard heaters, boiler controls and accessories. These systems are engineered to meet specific heating requirements. Once design requirements are known, use the figures that follow to estimate the cost of a complete installed system. For pipe, fittings, hangers and insulation costs, see the Commercial and Industrial section. For more detailed coverage, see the *National Plumbing & HVAC Estimator*, <https://craftsman-book.com/national-estimator-cloud>.

Hydronic boilers. U.S. Green Council and ASME "H" stamp certified to a rating of 95% AFUE (annual fuel usage efficiency) with EPA Tier II Nox emissions compliant burner, Kunkel safety valve, low-water cutoff, digital panel controls and automatic level controls. Weil-McClain UE-3 series or equal.

37,500 Btu with standard gas pilot	P1@3.00	Ea	2,100.00	112.00	2,212.00
62,000 Btu with standard gas pilot	P1@3.50	Ea	2,500.00	130.00	2,630.00
96,000 Btu with standard gas pilot	P1@3.50	Ea	2,750.00	130.00	2,880.00
130,000 Btu with standard gas pilot	P1@4.00	Ea	3,160.00	149.00	3,309.00
164,000 Btu with standard gas pilot	P1@4.00	Ea	3,620.00	149.00	3,769.00
198,000 Btu with standard gas pilot	P1@4.00	Ea	4,150.00	149.00	4,299.00
Add for electronic ignition	—	Ea	399.00	—	399.00

LEED certification for hydronic boilers. Requires 88% boiler efficiency, recording controls, compliance with SCAQMD 1146.2 emission standards and zone thermostats.

Add for LEED certification, per project	—	Ea	—	—	2,000.00
Add for central performance monitor/recorder	—	Ea	1,200.00	—	1,200.00
Add for zone recording thermostat	—	Ea	170.00	—	170.00
Add for a LEED certified boiler with USGBC rating	—	%	15.0	—	—

Heating, Hydronic

	Craft@Hrs	Unit	Material	Labor	Total
Air eliminator-purger, threaded connections					
3/4", cast iron, steam & water, 150 PSI	P1@.250	Ea	499.00	9.31	508.31
3/4", cast iron, 150 PSI water	P1@.250	Ea	160.00	9.31	169.31
1", cast iron, 150 PSI water	P1@.250	Ea	186.00	9.31	195.31
3/8", brass, 125 PSI steam	P1@.250	Ea	130.00	9.31	139.31
1/2", cast iron, 250 PSI steam	P1@.250	Ea	272.00	9.31	281.31
3/4", cast iron, 250 PSI steam	P1@.250	Ea	344.00	9.31	353.31
Airtrol fitting, 3/4"	P1@.300	Ea	58.40	11.20	69.60
Air eliminator vents	P1@.150	Ea	19.80	5.58	25.38
Atmospheric (anti-siphon) vacuum breakers, rough brass, threaded					
1/2" vacuum breaker	P1@.210	Ea	33.60	7.82	41.42
3/4" vacuum breaker	P1@.250	Ea	36.00	9.31	45.31
1" vacuum breaker	P1@.300	Ea	57.00	11.20	68.20
1-1/4" vacuum breaker	P1@.400	Ea	94.50	14.90	109.40
1-1/2" vacuum breaker	P1@.450	Ea	112.00	16.70	128.70
2" vacuum breaker	P1@.500	Ea	166.00	18.60	184.60
Circuit balancing valves, bronze, threaded					
1/2" circuit balancing valve	P1@.210	Ea	84.10	7.82	91.92
3/4" circuit balancing valve	P1@.250	Ea	89.50	9.31	98.81
1" circuit balancing valve	P1@.300	Ea	104.00	11.20	115.20
1-1/2" circuit balancing valve	P1@.450	Ea	162.00	16.70	178.70
Baseboard fin tube radiation, per linear foot, copper tube with aluminum fins, wall mounted					
1/2" element and 8" cover	P1@.280	LF	13.00	10.40	23.40
3/4" element and 9"cover	P1@.280	LF	21.20	10.40	31.60
3/4" element, 10" cover, high capacity	P1@.320	LF	33.40	11.90	45.30
3/4" fin tube element only	P1@.140	LF	8.41	5.21	13.62
1" fin tube element only	P1@.150	LF	10.10	5.58	15.68
8" cover only	P1@.140	LF	7.85	5.21	13.06
9" cover only	P1@.140	LF	9.55	5.21	14.76
10" cover only	P1@.160	LF	10.40	5.96	16.36
Add for pipe connection and control valve	P1@2.15	Ea	207.00	80.00	287.00
Add for corners, fillers, caps, average per foot	—	%	10.0	—	—
Flow check valves, brass, threaded, horizontal type					
3/4" check valve	P1@.250	Ea	21.50	9.31	30.81
1" check valve	P1@.300	Ea	22.60	11.20	33.80
Thermostatic mixing valves					
1/2", soldered	P1@.240	Ea	53.00	8.93	61.93
3/4", threaded	P1@.250	Ea	68.50	9.31	77.81
3/4", soldered	P1@.300	Ea	58.40	11.20	69.60
1", threaded	P1@.300	Ea	267.00	11.20	278.20
Liquid level gauges					
1/2", 175 PSI bronze	P1@.210	Ea	89.70	7.82	97.52
Wye pattern strainers, threaded, Class 125, bronze body valves					
3/4" strainer	P1@.260	Ea	44.60	9.68	54.28
1" strainer	P1@.330	Ea	54.70	12.30	67.00
1-1/4" strainer	P1@.440	Ea	76.20	16.40	92.60
1-1/2" strainer	P1@.495	Ea	114.00	18.40	132.40
2" strainer	P1@.550	Ea	199.00	20.50	219.50
Boiler expansion tank					
2.1 gallon	P1@.300	Ea	44.10	11.20	55.30
4.5 gallon	P1@.300	Ea	73.30	11.20	84.50

Heating Systems, Hydronic Radiant Floor

Craft@Hrs Unit Material Labor Total

Installation of packaged hydronic boilers. Add the cost of control wiring, supply lines (electric, feedwater and gas), drain line, circulating pump, vent stack, permits, final inspection and rental of an appliance dolly, come-a-long, a 1/2 ton chain hoist or a forklift, if required.

Place 4' x 4' x 1/2" vibration pads	CF@.750	Ea	44.90	26.90	71.80
Bolt down boiler	P1@1.00	Ea	39.10	37.20	76.30
Connect gas and feedwater lines	P1@2.50	Ea	—	93.10	93.10
Mount interior boiler drain	P1@.500	Ea	8.74	18.60	27.34
Bore pipe hole in basement wall	P1@.250	Ea	—	9.31	9.31
Bore burner stack vent in exterior wall	P1@.250	Ea	—	9.31	9.31
Mount and edge-seal stack	P1@.500	Ea	44.90	18.60	63.50
Mount circulating pump	P1@.450	Ea	—	16.70	16.70

Hydronic radiant floor heating systems Includes PEX (cross-linked polyethylene) tube, the circulating pump, boiler, expansion tank, manifold, return piping, hangers, insulation, thermostatic controls, service fill and drain fittings, anti-crimp pipe support spacers, system commissioning and startup. Add the cost of control wiring, gas and electric connection, permit and post-installation inspection. By rated boiler capacity. Typically, 35,000 Btu per hour in boiler capacity will heat a 2,500 SF home.

Embedded system. 5/8" tube set 12" O.C. in a concrete slab. Includes 1" extruded polystyrene insulation under interior areas and 2" extruded polystyrene insulation at the building perimeter, forms, supports, mesh reinforcing and the concrete.

35,000 Btu per hour (2,500 SF of floor)	P1@120.	Ea	6,840.00	4,470.00	11,310.00
70,000 Btu per hour (5,000 SF of floor)	P1@200.	Ea	10,800.00	7,440.00	18,240.00
105,000 Btu per hour (7,500 SF of floor)	P1@280.	Ea	16,700.00	10,400.00	27,100.00

Thin-slab system. 5/8" tube fastened 12" O.C. to the top of a wood-frame subfloor installed by others and then covered with 1-1/2" plasticized concrete.

35,000 Btu per hour (2,500 SF of floor)	P1@160.	Ea	5,670.00	5,960.00	11,630.00
70,000 Btu per hour (5,000 SF of floor)	P1@300.	Ea	9,680.00	11,200.00	20,880.00
105,000 Btu per hour (7,500 SF of floor)	P1@400.	Ea	12,900.00	14,900.00	27,800.00
Add per SF of floor for a poured gypsum cover	—	SF	2.52	—	2.52
Add for installation in an existing structure	—	%	—	—	80.0

Plate-type system. 3/4" tube fastened 8" O.C. with aluminum heat transfer plates either above or below a wood-frame subfloor installed by others.

35,000 Btu per hour (2,500 SF of floor)	P1@100.	Ea	4,890.00	3,720.00	8,610.00
70,000 Btu per hour (5,000 SF of floor)	P1@175.	Ea	8,360.00	6,510.00	14,870.00
105,000 Btu per hour (7,500 SF of floor)	P1@240.	Ea	12,200.00	8,930.00	21,130.00
Add for installation in an existing structure	—	%	—	—	50.0

Hybrid central heating and cooling High air velocity and narrow duct type. Attic or basement mounted modular system. Cooling is with a R410A refrigerant-charged A/C unit. Heating is with an electric hot water heating system. Rated at 13 SEER (Seasonal Energy Efficiency Rating). Provides precision zone control and low humidity for retrofit projects required to meet high energy-efficiency performance standards.

Includes automatic mode switchover, individual zone digital thermostats, digital main controller module, transition-mounted duct fans and motor drive, hot water coils and a circulating pump mounted in the air handling unit. Designed for HVAC upgrades of historic buildings, condo conversions and for meeting stringent indoor air quality and occupant comfort standards. See central air filter systems in the section that follows. Add the cost of a hot water expansion tank. Add the cost of equipment rental, if required: an appliance dolly, a 3,000 lb. come-a-long and a 1-ton chain hoist.

Mount and bolt down hybrid A/C unit, hot water coils and air handler enclosure

2.0-ton	P1@.750	Ea	7,360.00	27.90	7,387.90
3.0-ton	P1@.750	Ea	8,690.00	27.90	8,717.90
3.5-ton	P1@.750	Ea	8,950.00	27.90	8,977.90
4.0-ton	P1@.750	Ea	10,400.00	27.90	10,427.90
5.0-ton	P1@.750	Ea	11,700.00	27.90	11,727.90

Heating, Electric

	Craft@Hrs	Unit	Material	Labor	Total
Installation for hybrid central heating					
Reinforce joists in an attic	B1@3.00	LS	533.00	102.00	635.00
Place two vibration pads	CF@.750	LS	47.60	26.90	74.50
Core-drill and mount A/C drain	P1@.150	LF	3.49	5.58	9.07
Mount air mover in air handler duct	P1@.120	Ea	—	4.47	4.47
Connect ductwork mains to manifold	P1@4.50	Ea	176.00	167.00	343.00
Cut and braze copper A/C coil piping and run condensate drain	P1@4.00	Ea	10.60	149.00	159.60
Mount high-velocity ductwork and silencer tubing	P1@0.10	LF	21.50	3.72	25.22
Digital zone control thermostat, manual	BE@.750	Ea	139.00	30.80	169.80
Digital master heat/cool controller unit with auto change-over	BE@.750	Ea	349.00	30.80	379.80
Wiring of controls, typical	BE@3.00	Ea	1.93	123.00	124.93
Calibration and test	BE@2.00	Ea	—	82.10	82.10

Electric Heating Labor includes installation and connecting only. Add the cost of wiring from the Commercial and Industrial section of this manual.

Electric baseboard heaters, convection type, surface mounted, 20 gauge steel. Labor includes installation and connecting only. Add the cost of wiring. 7" high, 3-1/4" deep, 3.41 Btu/hr/watt, 240 volt. Low or medium density.

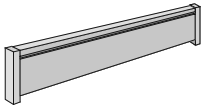

2'6" long, 500 watt (1,700 Btu)	BE@1.70	Ea	26.30	69.80	96.10
3'0" long, 750 watt (2,225 Btu)	BE@1.81	Ea	30.70	74.30	105.00
4'0" long, 1,000 watt (3,400 Btu)	BE@1.81	Ea	43.00	74.30	117.30
6'0" long, 1,500 watt (5,100 Btu)	BE@1.89	Ea	71.40	77.50	148.90
8'0" long, 2,000 watt (6,800 Btu)	BE@2.04	Ea	117.00	83.70	200.70
Add for integral thermostat	BE@.094	Ea	34.70	3.86	38.56
Add for wall mounted thermostat	BE@1.62	Ea	51.00	66.50	117.50

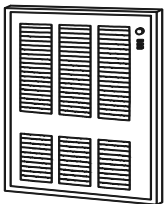

Fan-forced electric wall heaters, 12-3/4" x 6" rough opening. Add for 240 volt wiring and thermostat.

700/900/1600 watt, 50 CFM	BE@.650	Ea	188.00	26.70	214.70
500 watt, 6.25 amp, 5118 Btu, 83 CFM	BE@.650	Ea	163.00	26.70	189.70
1,000 watt, 4.17 amp, 3412 Btu, 83 CFM	BE@.650	Ea	163.00	26.70	189.70
2,000 watt, 8.33 amp, 6824 Btu, 60 CFM	BE@.650	Ea	188.00	26.70	214.70
2,000 watt, 8.33 amp, 6824 Btu, 83 CFM	BE@.650	Ea	140.00	26.70	166.70
3,000 watt, 12.5 amp, 12,236 Btu, 65 CFM	BE@.650	Ea	203.00	26.70	229.70
Double pole thermostat, 120 or 240 volt	BE@.440	Ea	44.60	18.10	62.70

Surface mounted 1" thick radiant ceiling panels. 120/208/240/277 volts AC.

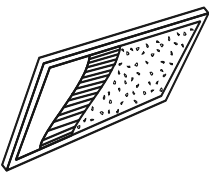

250 watts, 24" x 24"	BE@.850	Ea	191.00	34.90	225.90
310 watts, 24" x 24"	BE@.850	Ea	199.00	34.90	233.90
375 watts, 24" x 24"	BE@.850	Ea	213.00	34.90	247.90
625 watts, 24" x 48"	BE@1.11	Ea	324.00	45.50	369.50
750 watts, 24" x 48"	BE@1.31	Ea	340.00	53.70	393.70
Add for radiant line voltage wall thermostat	BE@.450	Ea	126.00	18.50	144.50
Add for motion sensing setback thermostat	BE@.450	Ea	129.00	18.50	147.50

Floor units, drop-in type, 14" long x 7-1/4" wide, includes fan motor assembly, housing and grille

120 volts, 375 or 750 watts	BE@1.76	Ea	376.00	72.20	448.20
277 volts, 750 watts	BE@1.76	Ea	463.00	72.20	535.20
Add for wall thermostat kit	BE@1.62	Ea	126.00	66.50	192.50
Add for concrete accessory kit and housing	—	LS	27.50	—	27.50

Infrared quartz tube heaters, indoor or outdoor, chromed guard, polished aluminum reflector. Includes modulating control.

3.2 KW, 24" long, 240 volts	BE@4.14	Ea	537.00	170.00	707.00
5 KW, 33" long, 240 volts	BE@4.14	Ea	708.00	170.00	878.00

Heating, Gas

	Craft@Hrs	Unit	Material	Labor	Total
7.3 KW, 46" long, 480 volts	BE@4.14	Ea	890.00	170.00	1,060.00
10.95 KW, 46" long, 480 volts	BE@4.14	Ea	1,490.00	170.00	1,660.00
Add for wall or ceiling brackets (pair)	—	LS	22.20	—	22.20
Deduct for indoor use only	—	%	-30.0	—	—
Suspension blower heaters, 208 or 240 volts, single phase, propeller type, direct drive					
1/4 HP	BE@4.80	Ea	468.00	197.00	665.00
1/3 HP	BE@4.80	Ea	546.00	197.00	743.00
1/2 HP	BE@4.80	Ea	761.00	197.00	958.00
Add for wall mounting bracket	—	LS	28.50	—	28.50
Add for line voltage wall thermostat					
Single pole	—	LS	50.20	—	50.20
Double pole	—	LS	75.40	—	75.40
Wall mounted fan-forced downflow insert heaters, heavy duty, built-in thermostat, 240 volts, 14" wide, 20" high, 4" deep rough-in, 3.41 Btu per hr per watt					
1,500 watts	BE@3.95	Ea	208.00	162.00	370.00
2,000 watts	BE@3.95	Ea	226.00	162.00	388.00
3,000 watts	BE@3.95	Ea	237.00	162.00	399.00
4,500 watts	BE@3.95	Ea	287.00	162.00	449.00
Add for surface mounting kit	—	LS	30.00	—	30.00

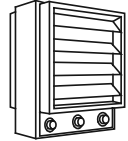

Central air filter for hybrid central heating system Drop-in module to fit in a high-velocity narrow duct air handling unit. Complies with Mil-STD 282 (certified removal of 99% of dust particles over .3 microns in size) as well as ASHRAE specifications. For residences requiring hypoallergenic air quality, medical clinics and pharmaceutical manufacturing/test facilities. DOP filter (di-octyl phthalate) is a non-woven denier nylon/cellulose acetate composite with an activated carbon final layer. Optional Dwyer-type pressure differential switch and relay provides automatic shutdown of the air handling unit and a warning light when filter elements are clogged. Pressure drop across the filter is 1" to 2" W.C. (water column). Sized by the nominal tonnage of associated cooling/heating equipment.

Central air filter

2.5-ton unit, drop in filter	P1@.100	Ea	716.00	3.72	719.72
3.0-ton unit, drop in filter	P1@.100	Ea	756.00	3.72	759.72
3.5-ton unit, drop in filter	P1@.100	Ea	759.00	3.72	762.72
4.0-ton unit, drop in filter	P1@.100	Ea	798.00	3.72	801.72
5.0-ton unit, drop in filter	P1@.100	Ea	842.00	3.72	845.72
Mount Dwyer switch on the air handler	BE@.500	Ea	188.00	20.50	208.50
Wiring of Dwyer switch	BE@1.00	Ea	63.00	41.00	104.00
Calibration and test	BE@.500	Ea	—	20.50	20.50

Gas Furnaces Add the cost of piping, electrical connection and vent. See pipe costs in the Commercial and Industrial section of this manual. For more detailed coverage of gas heating, see the *National Plumbing & HVAC Estimator*, <https://craftsman-book.com/national-estimator-cloud>.

Gravity gas wall furnace. Natural gas or propane fired.

8,000 Btu	PM@4.67	Ea	944.00	205.00	1,149.00
25,000 Btu	PM@4.67	Ea	573.00	205.00	778.00
25,000 Btu, high altitude	PM@4.67	Ea	1,100.00	205.00	1,305.00
35,000 Btu	PM@4.67	Ea	685.00	205.00	890.00
50,000 Btu	PM@4.67	Ea	814.00	205.00	1,019.00
Wall register kit for 2nd room	PM@1.00	Ea	64.60	43.90	108.50
Add for wall thermostat	PM@.972	Ea	59.50	42.70	102.20
Add for blower	PM@.500	Ea	170.00	21.90	191.90
Add for vent starter kit	PM@.254	LS	195.00	11.10	206.10
Add for gas valve for thermostat	PM@.250	Ea	178.00	11.00	189.00

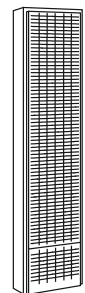

Heating, Gas

	Craft@Hrs	Unit	Material	Labor	Total
Direct vent gas wall furnace. Includes wall thermostat. No electricity required. Includes vent kit to outside wall. By input Btu rating. Natural gas or propane fired.					
14,000 Btu	PM@2.98	Ea	954.00	131.00	1,085.00
22,000 Btu	PM@2.98	Ea	1,170.00	131.00	1,301.00
30,000 Btu	PM@2.98	Ea	948.00	131.00	1,079.00
40,000 Btu	PM@2.98	Ea	1,570.00	131.00	1,701.00
Add for vent extension	PM@.500	Ea	74.50	21.90	96.40
Add for blower	PM@.500	Ea	164.00	21.90	185.90
Add for gas valve for thermostat	PM@.250	Ea	178.00	11.00	189.00
Gas floor furnace, including vent at \$80, valve and wall thermostat					
30 MBtu input, 24 MBtu output	PM@7.13	Ea	1,250.00	313.00	1,563.00
50 MBtu input, 35 MBtu output	PM@8.01	Ea	1,420.00	352.00	1,772.00
Add for furnace serving two rooms	—	%	30.0	—	—
Add for spark ignition	—	LS	80.90	—	80.90
Forced air upflow gas furnace with electronic ignition. Includes vent at \$100, typical piping, at \$50, thermostat at \$40 and distribution plenum at \$100. No ducting included.					
50 MBtu input, 48 MBtu output	PM@7.13	Ea	4,050.00	313.00	4,363.00
75 MBtu input, 70 MBtu output	PM@7.13	Ea	4,260.00	313.00	4,573.00
100 MBtu input, 92 MBtu output	PM@7.80	Ea	4,510.00	342.00	4,852.00
125 MBtu input, 113 MBtu output	PM@7.80	Ea	4,820.00	342.00	5,162.00
Add for liquid propane models	—	LS	415.00	—	415.00
Add for time control thermostat	—	Ea	129.00	—	129.00
Ductwork for forced air furnace. Sheet metal, 6 duct and 2 air return residential system, with typical elbows and attaching boots.					
4" x 12" registers, and 2" R-5 insulation	SW@22.1	LS	1,280.00	940.00	2,220.00
Add for each additional duct run	SW@4.20	Ea	278.00	179.00	457.00
Fiberglass flex duct, insulated, 8" dia.	SW@.012	LF	5.46	.51	5.97
Suspended space heater, fan-forced, with tubular aluminum heat exchanger, mounting brackets and gas valve. Includes vent to 30' at \$100, typical gas piping, at \$50, and thermostat, at \$40.					
30 MBtu input, 24 MBtu output	PM@2.75	Ea	1,040.00	121.00	1,161.00
45 MBtu input, 36 MBtu output	PM@2.75	Ea	1,150.00	121.00	1,271.00
60 MBtu input, 48 MBtu output	PM@2.75	Ea	1,220.00	121.00	1,341.00
75 MBtu input, 60 MBtu output	PM@2.75	Ea	1,350.00	121.00	1,471.00
Evaporative coolers , for roof installation. Costs include motor and electrical switch and connections.					
3,000 CFM, down draft	PM@11.1	Ea	524.00	487.00	1,011.00
3,000 CFM, side draft	PM@11.1	Ea	524.00	487.00	1,011.00
4,000 CFM, side draft	PM@11.1	Ea	594.00	487.00	1,081.00
4,300 CFM, down draft	PM@11.1	Ea	654.00	487.00	1,141.00
5,500 CFM, down draft	PM@11.1	Ea	764.00	487.00	1,251.00
5,500 CFM, side draft	PM@11.1	Ea	524.00	487.00	1,011.00
Window type air conditioners High-efficiency 115 volt units, adjustable thermostat, with remote. Labor is for installation in an existing wall opening, connected to an existing electric outlet.					
5,000 Btu, 150 SF room	PM@.751	Ea	163.00	33.00	196.00
8,000 Btu, 340 SF room	PM@.751	Ea	289.00	33.00	322.00
10,000 Btu, 450 SF room	PM@.751	Ea	361.00	33.00	394.00
15,000 Btu, 800 SF room	PM@.751	Ea	501.00	33.00	534.00
25,000 Btu, 1,500 SF room, 240 V	PM@.751	Ea	973.00	33.00	1,006.00

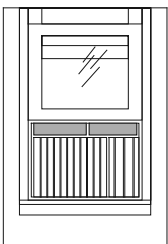

Heat Pumps

Craft@Hrs Unit Material Labor Total

Packaged split system electric heat pumps Window-wall units with galvanized steel cabinet, 35' of tubing, two thermostats and control package. Installed on a concrete pad. Add for the electrical connection and concrete work.

8 Mbtu cooling, 5 Mbtu heating	PM@10.9	Ea	1,410.00	478.00	1,888.00
15 Mbtu cooling, 13 Mbtu heating	PM@10.9	Ea	2,020.00	478.00	2,498.00
18 Mbtu cooling, 16 Mbtu heating	PM@12.9	Ea	2,270.00	566.00	2,836.00
Add for electrical connections, typical	PM@14.0	LS	294.00	614.00	908.00

Ductless mini-split heating and cooling units Includes pad-mounted compressor-condenser, 15' of insulated copper refrigerant lines, PVC condensate drain, control wiring, PVC wall chase, clamps, brackets, interior wall-mounted evaporator and wireless control. Add the cost of an exterior mounting slab, electrical connection and a NEC-approved safety switch.

Single zone units

9,000 BTU, ¾ ton, 230V	PM@3.59	Ea	977.00	158.00	1,135.00
9,000 BTU, ¾ ton, 115V	PM@3.59	Ea	1,050.00	158.00	1,208.00
12,000 BTU, 1 ton, 230V	PM@3.84	Ea	1,260.00	169.00	1,429.00
18,000 BTU, 1-1/2 ton, 230V	PM@3.84	Ea	1,430.00	169.00	1,599.00
24,000 BTU, 2 ton, 230V	PM@3.84	Ea	1,770.00	169.00	1,939.00
36,000 BTU, 3 ton, 230V	PM@4.09	Ea	2,400.00	180.00	2,580.00
42,000 BTU, 3-1/2 ton, 230V, ceiling mount	PM@7.18	Ea	3,450.00	315.00	3,765.00

Multi zone units

24,000 BTU, 2 ton, 230V, 2 zones	PM@4.67	Ea	2,800.00	205.00	3,005.00
24,000 BTU, 2 ton, 230V, 3 zones	PM@5.60	Ea	3,140.00	246.00	3,386.00
36,000 BTU, 3 ton, 230V, 3 zones	PM@5.60	Ea	2,710.00	246.00	2,956.00
36,000 BTU, 3 ton, 230V, 4 zones	PM@7.00	Ea	4,210.00	307.00	4,517.00
42,000 BTU, 3-1/2 ton, 230V, 5 zones	PM@8.17	Ea	4,950.00	359.00	5,309.00

Add for 4" concrete slab, to 3' x 3'

B1@1.40	LS	44.40	47.80	92.20
---------	----	-------	-------	-------

Add for electrical connection and safety switch

BE@3.25	LS	100.00	133.00	233.00
---------	----	--------	--------	--------

Residential air-to-air heat pump Forced-air-aspirated heat pump, split system, slab mounted. Rated in nominal tonnage. Agency rating ARI and CSA. Installed in an existing air handling unit and with an optional filtration system. See the sections that follow. Trane or equal, rated at 13 SEER (Seasonal Energy Efficiency Rating), with automatic reversing valve for switching between heating and cooling modes, semiconductor thermocouple sensor for monitoring indoor/outdoor temperature differential, interior thermostat, controller relay, digital controller module, centrifugal compressor and motor drive. 208/230 V, 60 Hz, single phase. Requires two fan-aspirated pre-charged R410A refrigerant evaporator coils, one interior in the air handling unit and one outside in a weatherproof enclosure. See the air handler and evaporator coils that follow. Add, if required, for the cost of an appliance dolly, 3,000 lb. come-a-long and 1-ton chain hoist.

Mount and bolt interior heat pump unit in air handler enclosure

2.0-ton unit	P1@.750	Ea	2,660.00	27.90	2,687.90
3.0-ton unit	P1@.750	Ea	2,930.00	27.90	2,957.90
3.5-ton unit	P1@.750	Ea	3,550.00	27.90	3,577.90
4.0-ton unit	P1@.750	Ea	3,800.00	27.90	3,827.90
5.0-ton unit	P1@.750	Ea	4,430.00	27.90	4,457.90

Place 4' x 4' x 1/2"

vibration pads	CF@.750	Ea	44.80	26.90	71.70
----------------	---------	----	-------	-------	-------

Mount interior

evaporator drain	P1@.500	Ea	8.99	18.60	27.59
------------------	---------	----	------	-------	-------

Bore piping hole

through external coil	P1@.250	Ea	—	9.31	9.31
-----------------------	---------	----	---	------	------

Mount and bolt down the

external coil	P1@.450	Ea	33.50	16.70	50.20
---------------	---------	----	-------	-------	-------

Heating and Cooling, LEED Certified

	Craft@Hrs	Unit	Material	Labor	Total
Mount interior evaporator coil in air handler duct	P1@1.20	Ea	—	44.70	44.70
Tie-in of connecting ductwork to house air ductwork manifold and exhaust	P1@4.50	Ea	171.00	167.00	338.00
Cut and braze copper evaporator coil piping & drain	P1@4.00	Ea	9.52	149.00	158.52
Heat pump accessories					
Wiring of controls	BE@3.00	Ea	1.71	123.00	124.71
Calibration and test	BE@2.00	Ea	—	82.10	82.10
Fossil fuel kit	P1@2.50	Ea	285.00	93.10	378.10
High pressure cut-out kit	P1@.500	Ea	64.40	18.60	83.00
Outdoor stat/Low ambient sensors	BE@.500	Ea	69.80	20.50	90.30
Short cycle protection	BE@.500	Ea	86.90	20.50	107.40
Digital heat/cool thermostat, manual	BE@.750	Ea	149.00	30.80	179.80
Digital, programmable heat/cool thermostat with auto change-over	BE@.750	Ea	357.00	30.80	387.80
Heat pump supplemental electric heating coil					
5 KW, 208/230 Volt, 1-phase, 60 Hz	BE@1.50	Ea	177.00	61.50	238.50
7.5 KW, 208/230 Volt, 1-phase, 60 Hz	BE@1.75	Ea	203.00	71.80	274.80
10 KW, 208/230 Volt, 1-phase, 60 Hz	BE@2.00	Ea	221.00	82.10	303.10
12.5 KW, 208/230 Volt, 1-phase, 60 Hz	BE@2.25	Ea	316.00	92.30	408.30
15 KW, 208/230 Volt, 1-phase, 60 Hz	BE@2.75	Ea	443.00	113.00	556.00
20 KW, 208/230 Volt, 1-phase, 60 Hz	BE@3.50	Ea	596.00	144.00	740.00
25 KW, 208/230 Volt, 1-phase, 60 Hz	BE@4.25	Ea	664.00	174.00	838.00

Residential central air handling unit Two-piece 16-gauge steel sheet metal enclosure with main inlet and exhaust ductwork tie-ins and inlet dust filter mount. With 208/230 volt single-phase 60 Hz variable-speed fan, relay and control and breaker box. Designed to accommodate an optional evaporator coil, “drop-in” oil or gas heater to fit an existing integral air-to-air heat exchanger, electric heater coil or hot water/steam coil and filter (not included). See the sections that follow. Add for LEED certification if required.

Mount and bolt down air handler

2.0-ton	P1@.750	Ea	1,460.00	27.90	1,487.90
3.0-ton	P1@.750	Ea	1,720.00	27.90	1,747.90
3.5-ton	P1@.750	Ea	2,000.00	27.90	2,027.90
4.0-ton	P1@.750	Ea	2,110.00	27.90	2,137.90
5.0-ton	P1@.750	Ea	2,380.00	27.90	2,407.90

Mount internal evaporator coil in

an air handler	P1@1.20	Ea	66.40	44.70	111.10
Tie-in of connecting interior ductwork to house air ductwork manifold and exhaust	P1@4.50	Ea	127.00	167.00	294.00
Cut and braze copper evaporator coil piping and drain	P1@4.00	Ea	10.10	149.00	159.10
Wiring of controls	BE@3.00	Ea	1.91	123.00	124.91
Calibration and test	BE@2.00	Ea	—	82.10	82.10

Evaporator coils for a residential air handler Uncased, pre-charged with R32 refrigerant, with flanged mounting base plate, connector tubing, refrigerant fill valve and check valve, twin-finned radiator baffles. For use in conjunction with heat pump units, to be mounted indoors in air handler or air handler ductwork; cased units are to be used for outdoor mounting. Sized by the associated nominal tonnage of the heat pump. Add for LEED certification if required.

Place two 4' x 4' x 1/2" (vibration pads)	CF@.300	Ea	61.30	10.80	72.10
Mount interior evaporator drain	P1@.500	Ea	9.80	18.60	28.40
Bore piping hole through exterior wall	P1@.250	Ea	—	9.31	9.31

HVAC

	Craft@Hrs	Unit	Material	Labor	Total
Mount external evaporator coil					
2.0-ton	P1@.750	Ea	536.00	27.90	563.90
3.0-ton	P1@.750	Ea	573.00	27.90	600.90
3.5-ton	P1@.750	Ea	618.00	27.90	645.90
4.0-ton	P1@.750	Ea	833.00	27.90	860.90
5.0-ton	P1@.750	Ea	954.00	27.90	981.90
Mount interior evaporator coil in air handler duct					
2.0-ton	P1@1.75	Ea	492.00	65.10	557.10
3.0-ton	P1@1.75	Ea	553.00	65.10	618.10
3.5-ton	P1@1.75	Ea	614.00	65.10	679.10
4.0-ton	P1@1.75	Ea	674.00	65.10	739.10
5.0-ton	P1@1.75	Ea	736.00	65.10	801.10
Tie-in of connecting interior ductwork manifold and exhaust	P1@4.50	Ea	122.00	167.00	289.00
Cutting and brazing of copper evaporator coil piping and drain	P1@4.00	Ea	9.61	149.00	158.61
Wiring of controls	BE@3.00	Ea	1.81	123.00	124.81
Calibration and test	BE@2.00	Ea	—	82.10	82.10

LEED Certified Heating and Cooling (Leadership in Energy & Environmental Design) offers an incentive to building owners to install energy-efficient and environmentally sensitive heating and cooling equipment. The HVAC system can earn a maximum of 17 points toward LEED certification by meeting ASHRAE 90 standards. A LEED certified air conditioning system must also meet ASHRAE 62.1-2016 standards for indoor air quality and include recording controls to measure system performance.

Add for LEED certification, registration and inspection, per project	—	Ea	2,540.00	—	2,540.00
Add for LEED central digital performance monitor/recorder, ComfortView 3 or equal	—	Ea	3,030.00	—	3,030.00
Add for LEED certified zone recording thermostat, USB remote-ready	—	Ea	452.00	—	452.00
Add for IAQ (Indoor Air Quality) CO2 sensor and duct-mounted aspirator box	—	Ea	550.00	—	550.00
Add for LEED certified residential systems with USGBC rating	—	%	20.0	—	—

Central air particulate removal filter system Residential or light commercial DOP (di-octyl phthalate) type. Provided as drop-in module to manually fit into an air handling units. Complies with Mil-STD 282 (certified removal of 99% of dust particles over .3 microns in size) as well as ASHRAE specifications. For homes, medical clinics and pharmaceutical manufacturing/test facilities. DOP filter type is non-woven denier nylon/cellulose acetate composite with activated carbon final layer. Optional Dwyer-type pressure differential switch and relay provides for automatic shutdown of air handling unit and triggering of signal light when filter elements are clogged with particulates and require cleaning or replacement. Pressure drop across filter is 1" W.C. (water column) to 2" W.C. Sized according to nominal tonnage of associated cooling/heating capacity.

Dropping in filter					
2.5-ton filter	P1@.100	Ea	918.00	3.72	921.72
3.0-ton filter	P1@.100	Ea	1,050.00	3.72	1,053.72
3.5-ton filter	P1@.100	Ea	1,120.00	3.72	1,123.72
4.0-ton filter	P1@.100	Ea	1,170.00	3.72	1,173.72
5.0-ton filter	P1@.100	Ea	1,240.00	3.72	1,243.72
Mount Dwyer switch on required air handler	BE@.500	Ea	197.00	20.50	217.50
Wiring of Dwyer switch	BE@1.00	Ea	65.50	41.00	106.50
Calibrate and test	BE@.500	Ea	20.50	20.50	41.00

Insulation

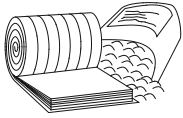

Craft@Hrs Unit Material Labor Total

Insulation See also Building Paper and Polyethylene Film. Coverage allows for studs and joists.
Fiberglass insulation, wall and ceiling application, coverage allows for framing

Kraft-faced, 16" OC framing members

3-1/2" (R-11)	BC@.007	SF	.49	.26	.75
3-1/2" (R-13)	BC@.007	SF	.60	.26	.86
3-1/2" (R-15)	BC@.007	SF	.94	.26	1.20
6-1/4" (R-19)	BC@.008	SF	.78	.30	1.08
5-1/2" (R-21)	BC@.008	SF	.98	.30	1.28
9-1/2" (R-30)	BC@.008	SF	1.05	.30	1.35
9-1/2" (R-30C) cathedral ceiling	BC@.010	SF	.90	.38	1.28
12" (R-38)	BC@.009	SF	1.50	.34	1.84

Kraft-faced, 24" OC framing members

3-1/2" (R-13)	BC@.005	SF	.60	.19	.79
3-1/2" (R-15)	BC@.005	SF	.58	.19	.77
6-1/4" (R-19)	BC@.006	SF	.80	.23	1.03
5-1/2" (R-21)	BC@.006	SF	.95	.23	1.18
9-1/2" (R-30)	BC@.006	SF	1.17	.23	1.40
12" (R-38)	BC@.007	SF	1.48	.26	1.74

Unfaced, 16" OC framing members

2" (R-6.7)	BC@.003	SF	1.12	.11	1.23
3-1/2" (R-13)	BC@.004	SF	.55	.15	.70
6-1/4" (R-19)	BC@.005	SF	.74	.19	.93
9-1/2" (R-30)	BC@.006	SF	1.08	.23	1.31

Unfaced, 24" OC framing members

6-1/4" (R-19)	BC@.003	SF	.71	.11	.82
9-1/2" (R-30)	BC@.004	SF	1.16	.15	1.31
12" (R-38)	BC@.005	SF	1.09	.19	1.28

Poly-faced insulation, vapor retarding twisted Miraflex fibers, ASTM C665, Type II, Class C, coverage allows for framing

3-1/2" (R-13), 16" or 24" OC framing	BC@.005	SF	.69	.19	.88
8-3/4" (R-25), 16" or 24" OC framing	BC@.006	SF	1.03	.23	1.26

Encapsulated fiberglass roll insulation, Johns Manville Comfort Therm™, coverage allows for framing

3-1/2" (R-13) rolls, 16" OC framing	BC@.005	SF	.54	.19	.73
6-1/4" (R-19) batts, 16" or 24" OC framing	BC@.006	SF	.92	.23	1.15
8-1/4" (R-25) rolls, 16" or 24" OC framing	BC@.006	SF	1.28	.23	1.51
10-1/4" (R-30) batts, 16" or 24" OC framing	BC@.006	SF	1.39	.23	1.62



Insulation board, Owens Corning Foamular XAE rigid extruded polystyrene foam board, film-faced, stapled in place, including taped joints, 4' x 8' or 9' panels, tongue and groove or square edge, including 5% waste

1/2" thick (R-2.5), 4' x 8' panel	BC@.010	SF	.44	.38	.82
3/4" thick (R-3.8), 4' x 8' panel	BC@.011	SF	.63	.41	1.04
1" thick (R-5.0), 4' x 8' panel	BC@.011	SF	.65	.41	1.06
1-1/2" thick (R-7.5), 4' x 8' panel	BC@.015	SF	.82	.56	1.38
2" thick (R-10), 4' x 8' panel	BC@.015	SF	.99	.56	1.55

Extruded polystyrene insulation panel, Dow Blue Board, water resistant. By thermal resistance value, (R-). Density of 1.6 lbs. per CF. Gray Board density is 1.3 lbs. per CF.

3/4" x 2' x 8', tongue & groove, R-3.8	BC@.011	SF	1.26	.41	1.67
1" x 2' x 8', R-5.0	BC@.011	SF	.79	.41	1.20
1" x 2' x 8', tongue & groove, R-5.0	BC@.011	SF	.53	.41	.94
1" x 4' x 8', R-5.0	BC@.011	SF	.83	.41	1.24
1" x 4' x 8', tongue & groove, R-5.0	BC@.011	SF	.77	.41	1.18
1-1/2" x 2' x 8', R-7.5	BC@.015	SF	1.38	.56	1.94
1-1/2" x 2' x 8', tongue & groove, R-7.5	BC@.015	SF	1.32	.56	1.88

Insulation

	Craft@Hrs	Unit	Material	Labor	Total
1-1/2" x 4' x 8', square edge, R-7.5	BC@.015	SF	1.38	.56	1.94
2" x 2' x 8', R-10	BC@.015	SF	1.52	.56	2.08
2" x 4' x 8', R-10	BC@.015	SF	1.43	.56	1.99
1" x 2' x 8' Gray Board (1.3 lbs. per CF)	BC@.015	SF	.77	.56	1.33
1-1/2" x 2' x 8' Gray Board	BC@.015	SF	1.10	.56	1.66
2" x 2' x 8' Gray Board	BC@.015	SF	1.41	.56	1.97
Rigid polyisocyanurate insulated sheathing, foil face on two sides, Dow/Celotex Tuff-R, 4' x 8' panels, including 5% waste.					
1/2" (R-3.3)	BC@.010	SF	.43	.38	.81
3/4" (R-5.6)	BC@.011	SF	.44	.41	.85
1" (R-5.9)	BC@.011	SF	.70	.41	1.11
1-1/2" (R-9.4)	BC@.011	SF	.79	.41	1.20
2" (R-13)	BC@.015	SF	1.16	.56	1.72
Fanfold extruded polystyrene insulation 4' x 50' panels, including 5% waste					
1/4" (R-1)	BC@.011	SF	.30	.41	.71
3/8" (R-1)	BC@.011	SF	.34	.41	.75
Add for nails, 25 lb cartons (large square heads)					
2-1/2", for 1-1/2" boards	—	LS	63.50	—	63.50
3", for 2" boards	—	LS	63.40	—	63.40
Foil-faced urethane sheathing, 4' x 8' panels, including 5% waste,					
1" (R-7.2)	BC@.011	SF	.65	.41	1.06
Asphalt impregnated sheathing board on walls, nailed, 4' x 8' panels					
1/2", standard	BC@.013	SF	.37	.49	.86
1/2", intermediate	BC@.013	SF	.47	.49	.96
1/2", nail base	BC@.013	SF	.66	.49	1.15
Dens Glass Gold insulating exterior sheathing. Glass mat embedded in a water-resistant treated gypsum core with bond-enhancing gold primer coating. Square edge.					
1/4" x 4' x 4' Dens-Shield	BC@.015	SF	.64	.56	1.20
1/2" x 32" x 4' Dens-Shield	BC@.015	SF	.53	.56	1.09
1/2" x 4' x 8'	BC@.016	SF	.73	.60	1.33
5/8" x 4' x 8'	BC@.016	SF	1.00	.60	1.60
Polystyrene foam underlay, polyethylene covered, R-Gard.					
3/8" x 4' x 24' fanfold	BC@.011	SF	.29	.41	.70
1/2" x 4' x 8'	BC@.011	SF	.28	.41	.69
3/8" x 4' x 8'	BC@.011	SF	.33	.41	.74
1" x 4' x 8'	BC@.011	SF	.40	.41	.81
1-1/2" x 2' x 8'	BC@.015	SF	.62	.56	1.18
2" x 2' x 8'	BC@.015	SF	.80	.56	1.36
Cant strips for insulated roof board, one piece wood, tapered					
2" strip	RR@.018	LF	.45	.75	1.20
3" strip	RR@.020	LF	.40	.84	1.24
4" strip	RR@.018	LF	.38	.75	1.13
Sill plate gasket. Fills gaps between the foundation and the plate. Also used for sealing around windows and doors.					
1/4" x 50', 3-1/2" wide	RR@.003	LF	.16	.13	.29
1/4" x 50', 5-1/2" wide	RR@.003	LF	.23	.13	.36
Perimeter foundation insulation, expanded polystyrene with polyethylene skinned surface. Low moisture retention. Minimum compressive strength of 1,440 lbs. per SF.					
3/4" x 4' x 8'	BC@.011	SF	.38	.41	.79
1-1/2" x 2' x 4'	BC@.015	SF	.84	.56	1.40
2" x 2' x 4'	BC@.015	SF	1.05	.56	1.61
2" x 4' x 4'	BC@.015	SF	.84	.56	1.40

Insulation

	Craft@Hrs	Unit	Material	Labor	Total
FBX 1240 industrial board insulation, rockwool, semi-rigid, no waste included, 24" OC framing members.					
2" (R-8)	BC@.004	SF	1.13	.15	1.28
3" (R-12)	BC@.004	SF	1.64	.15	1.79
3-1/2" (R-14)	BC@.004	SF	1.91	.15	2.06
Sound control insulation, fiberglass acoustically designed to absorb sound vibration, for use between interior walls, floors and ceilings, Quietzone™ batts, coverage allows for framing.					
3-1/2", 16" OC framing	BC@.006	SF	.47	.23	.70
3-1/2", 24" OC framing	BC@.006	SF	.47	.23	.70
Acoustic floor underlayment, 32 SF	BC@.003	SF	.66	.11	.77
Acoustic caulk, 28 oz. tube	—	Ea	8.39	—	8.39
Sound insulation board, 4' x 8' panels installed on walls					
1/2" Homasote	BC@.013	SF	1.44	.49	1.93
1/2" Soundstop	BC@.013	SF	.84	.49	1.33
1/2" Sound deadening board	BC@.013	SF	.73	.49	1.22
Add for installation on ceilings	BC@.004	SF	—	.15	.15
Sound Attenuation Fire Batt insulation (SAFB), rockwool, semi-rigid, no waste included, pressed between framing members					
16" OC framing members					
3-1/2" (R-15)	BC@.004	SF	.98	.15	1.13
5-1/2" (R-23)	BC@.004	SF	1.30	.15	1.45
7-1/2" (R-30)	BC@.005	SF	2.22	.19	2.41
24" OC framing members					
3-1/2" (R-15)	BC@.003	SF	.96	.11	1.07
5-1/2" (R-23)	BC@.003	SF	1.61	.11	1.72
7-1/2" (R-30)	BC@.004	SF	2.00	.15	2.15
Housewrap building envelope, wrapped on exterior walls and stapled, including 10% waste					
9' x 150' roll	BC@.006	SF	.20	.23	.43
Tyvek tape, 2" x 165'	—	Roll	14.40	—	14.40
Stabilized cellulose insulation, for blown-in applications. Bag covers 40 SF of attic joists at 6" depth. Add the cost of blower rental.					
40 SF bag	BC@.010	SF	.35	.38	.73
Vermiculite insulation, poured over ceilings					
Vermiculite, 25 lb sack (2 CF)	—	Ea	20.60	—	20.60
At 3" depth (120 sacks per 1,000 SF)	BL@.007	SF	2.47	.21	2.68
At 4" depth (144 sacks per 1,000 SF)	BL@.007	SF	2.96	.21	3.17
Masonry batts, 1-1/2" x 15" x 48"	B9@.008	SF	.32	.27	.59
Masonry fill, poured in concrete block cores					
Using 2 CF bags of perlite, per bag	—	Ea	9.18	—	9.18
4" wall, 8.1 SF per CF	B9@.006	SF	1.13	.20	1.33
6" wall, 5.4 SF per CF	B9@.006	SF	1.70	.20	1.90
8" wall, 3.6 SF per CF	B9@.006	SF	2.55	.20	2.75
Natural fiber building insulation. EPA registered anti-microbial agent offers protection from mold, mildew, fungi and pests. Made from all natural cotton fibers. Friction fit. 94" long batting. Based on Ultra Touch.					
16" OC framing (R-13)	BC@.005	SF	.61	.19	.80
16" OC framing (R-19)	BC@.006	SF	.71	.23	.94
16" OC framing (R-30)	BC@.007	SF	1.02	.26	1.28
24" OC framing (R-13)	BC@.006	SF	.88	.23	1.11
24" OC framing (R-19)	BC@.007	SF	1.64	.26	1.90
24" OC framing (R-30)	BC@.008	SF	1.60	.30	1.90

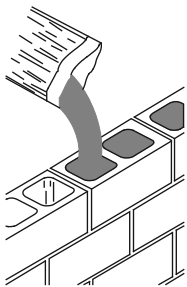

Insulation, Subcontract New construction, coverage includes framing.

Blown-in cellulose					
3-1/2" (R-12)	—	MSF	—	—	807.00
6" (R-21)	—	MSF	—	—	1,140.00

Insulation, Subcontract

	Craft@Hrs	Unit	Material	Labor	Total
Sprayed-on polyurethane open cell foam (rigid). 2-part, R-Value 3.5 per inch, low density, vapor permable, cost per CSF. minimum job size 5,000sf, subcontract					
R-13, 3.7" thick	—		CSF	—	146.00
R-17, 4.9" thick	—		CSF	—	188.00
R-22, 6.3" thick	—		CSF	—	242.00
R-26, 7.4" thick	—		CSF	—	289.00
R-30, 8.6" thick	—		CSF	—	334.00
R-38, 10.9" thick	—		CSF	—	423.00
R-45, 12.9" thick	—		CSF	—	501.00
R-60, 17.1" thick	—		CSF	—	669.00
Sprayed-on polyurethane closed cell foam (rigid). 2-part, R-Value 6.5 per inch, high density, impervious to vapor, cost per CSF. minimum job size 5,000sf, subcontract					
R-13, 2.0" thick	—		CSF	—	194.00
R-17, 2.6" thick	—		CSF	—	188.00
R-22, 3.4" thick	—		CSF	—	316.00
R-26, 4.0" thick	—		CSF	—	376.00
R-30, 4.6" thick	—		CSF	—	432.00
R-38, 5.8" thick	—		CSF	—	541.00
R-45, 6.9" thick	—		CSF	—	637.00
R-60, 9.2" thick	—		CSF	—	842.00
Sprayed-on urethane foam (rigid)					
1" thick	—		MSF	—	2,070.00
Add for acrylic waterproofing	—		MSF	—	1,420.00
Add for urethane rubber waterproofing	—		MSF	—	2,420.00
Add for cleaning rock off existing roof	—		MSF	—	128.00
Insulation blown into walls in an existing structure, includes coring hole in exterior or interior of wall, filling cavity, sealing hole and paint to match existing surface. R-12 to R-14 rating depending on cavity thickness					
Stucco (exterior application)	—		MSF	—	2,350.00
Wallboard (interior application)	—		MSF	—	2,350.00
Wood siding (exterior application)	—		MSF	—	3,110.00
Thermal Analysis (Infrared thermography) Includes infrared video inspection of entire building, written report by qualified technician or engineer, and thermograms (infrared photographs) of all problem areas of building. Inspection is done using high-quality thermal sensitive instrumentation. Costs listed are for exterior facade shots or interior (room by room) shots. All travel expenses for inspector are extra.					
Residence, typically 4 hours required	—	Hr	—	—	279.00
Commercial structure (\$800.00 minimum)	—	Hr	—	—	162.00
Add per day lost due to weather, lack of preparation by building occupants, etc., when inspector and equipment are at building site prepared to commence inspection					
Typical cost per day	—	LS	—	—	442.00
Add per night for accommodations when overnight stay is required. This is common when inspection must be performed at night to get accurate results					
Typical cost, per night	—	LS	—	—	152.00
Home Energy Rating System (HERS) Confirmed rating and index calculation by a certified Whole House Home Energy Rater. Some building departments require a HERS rating to verify building code compliance. Costs for rating a single-family home. Rating each unit of a multi-family dwelling will cost 25% to 50% less.					
Existing home HERS rating, repeated tests are the same price					
Duct pressure test, per system	—	Ea	—	—	228.00
Refrigerant charge verification	—	Ea	—	—	102.00
Maximum fan watt draw verification	—	Ea	—	—	51.00
Minimum airflow test, 3,500 CFM per ton	—	Ea	—	—	51.00
Add for data entry to calculate the HERS index	—	Ea	—	—	76.00

Insurance and Bonding

	Craft@Hrs	Unit	Material	Labor	Total
Typical duct test, refrigerant charge, airflow, fan watt draw with certificate processing	—	LS	—	—	508.00
Wait time to make adjustments for another test	—	Hr	—	—	91.00
New home energy rating, including plan review, software modeling, design specs, on-site inspections, performance testing, reports and certification, per home					
Certification for code compliance	—	Ea	—	—	761.00

Insurance and Bonding Typical rates. Costs vary by state and class of construction.

Rule of thumb: Employer's cost for payroll taxes, and insurance.

Per \$100 (C\$) of payroll	—	C\$	—	—	31.00
----------------------------	---	-----	---	---	-------

Rule of thumb: Complete insurance program (comprehensive general liability policy, truck, automobile, and equipment floaters and fidelity bond), contractor's typical cost

Per \$100 of payroll	—	C\$	—	—	7.37
----------------------	---	-----	---	---	------

Liability insurance Comprehensive contractor's liability insurance, including operations, completed operations, bodily injury and property damage, protective and contractual coverages, \$1,000,000 policy limit. Minimum annual premium will be between \$2,500 and \$10,000. Rates vary by state and with the contractor's loss experience. Typical costs per \$100 (C\$) of payroll for each trade employed. (Calculate and add for each category separately.)

General contractors	—	C\$	—	—	2.60
Carpentry	—	C\$	—	—	4.11
Concrete, formed or flat	—	C\$	—	—	5.27
Drywall hanging and finishing	—	C\$	—	—	3.55
Electrical wiring	—	C\$	—	—	3.58
Floor covering installation	—	C\$	—	—	4.74
Glaziers	—	C\$	—	—	3.55
Heating, ventilating, air conditioning	—	C\$	—	—	4.96
Insulation	—	C\$	—	—	4.11
Masonry, tile	—	C\$	—	—	3.90
Painting	—	C\$	—	—	5.38
Plastering and stucco	—	C\$	—	—	3.79
Plumbing	—	C\$	—	—	6.37

Workers' compensation coverage Rates vary from state to state and by a contractor's loss history.

Coverage cost per \$100 (C\$) of base payroll excluding fringe benefits.

Bricklayer	—	C\$	—	—	9.37
Carpenter					
1 and 2 family dwellings	—	C\$	—	—	15.30
Multiple units and commercial	—	C\$	—	—	5.32
Clerical (office worker)	—	C\$	—	—	.96
Concrete					
1 and 2 family dwellings	—	C\$	—	—	6.00
Other concrete	—	C\$	—	—	6.46
Construction laborer	—	C\$	—	—	15.30
Drywall taper	—	C\$	—	—	7.98
Electrical wiring	—	C\$	—	—	4.34
Elevator erectors	—	C\$	—	—	2.29
Executive supervisors	—	C\$	—	—	3.39
Excavation, grading	—	C\$	—	—	8.97
Excavation, rock (no tunneling)	—	C\$	—	—	11.70
Glazing	—	C\$	—	—	10.20
Insulation work	—	C\$	—	—	19.30
Iron or steel erection work	—	C\$	—	—	11.30
Lathing	—	C\$	—	—	5.25
Operating engineers	—	C\$	—	—	8.97

Insurance and Bonding

	Craft@Hrs	Unit	Material	Labor	Total
Painting and paperhanging	—	C\$	—	—	7.57
Pile driving	—	C\$	—	—	7.46
Plastering and stucco	—	C\$	—	—	12.60
Plumbing	—	C\$	—	—	6.06
Reinforcing steel installation (concrete)	—	C\$	—	—	11.30
Roofing	—	C\$	—	—	26.30
Sewer construction	—	C\$	—	—	8.80
Sheet metal work (on site)	—	C\$	—	—	9.05
Steam and boiler work	—	C\$	—	—	9.67
Tile, stone, and terrazzo work	—	C\$	—	—	5.52
Truck driver	—	C\$	—	—	8.97
Tunneling	—	C\$	—	—	19.30

Payment and performance bonds Cost per \$1,000 (M\$) of final contract price. Rates vary with the experience, credit rating and net worth of the applicant.

Preferred rates, contract coverage for:

First \$ 100,000	—	M\$	—	—	14.40
Next \$2,400,000	—	M\$	—	—	8.71
Next \$2,500,000	—	M\$	—	—	6.90

Standard rates, contract coverage for:

First \$ 100,000	—	M\$	—	—	30.00
Next \$ 400,000	—	M\$	—	—	18.10
Next \$2,000,000	—	M\$	—	—	12.00
Next \$2,500,000	—	M\$	—	—	9.01
Next \$2,500,000	—	M\$	—	—	8.41
Over \$7,500,000	—	M\$	—	—	7.80

Substandard rates, contract coverage for:

First \$100,000	—	M\$	—	—	36.00
Balance of contract	—	M\$	—	—	24.00

Ironing Centers, Built-In Wood frame with hinged door, can be recessed or surface mounted.

Includes one 110 volt control panel where shown, receptacle outlet, timed shutoff switch, spotlight, storage shelf, and steel ironing board. No electrical work included. Iron-A-Way Products.

Type 1, no electric control panel, non-adjustable 42" board,

48" high, 15" wide, 6" deep	BC@.994	Ea	335.00	37.40	372.40
-----------------------------	---------	----	--------	-------	--------

Type 2, with electric control panel, non-adjustable 42" board,

48" high, 15" wide, 6" deep	BC@.994	Ea	554.00	37.40	591.40
-----------------------------	---------	----	--------	-------	--------

Type 3, with electric control panel, adjustable 46" board,

61" high, 15" wide, 6" deep	BC@.994	Ea	767.00	37.40	804.40
-----------------------------	---------	----	--------	-------	--------

Added cost for any unit

Add for sleeve board with holder	—	Ea	45.00	—	45.00
Add for door mirror	—	Ea	155.00	—	155.00
Add for oak paneled door front	—	Ea	135.00	—	135.00
Add for hot iron rest	—	Ea	37.60	—	37.60

Jackposts, Steel, Adjustable Building Columns Permanent or temporary adjustable steel posts, 3" diameter.

16" maximum extension	B1@.250	Ea	36.00	8.53	44.53
19" to 36" extension	B1@.250	Ea	41.80	8.53	50.33
34" to 55" extension	B1@.250	Ea	53.10	8.53	61.63
54" to 93" extension	B1@.250	Ea	69.80	8.53	78.33
58" to 100" extension	B1@.250	Ea	82.00	8.53	90.53
Heavy duty jack post	B1@.250	Ea	106.00	8.53	114.53
Jack post beam plate with 3-1/2" ring	B1@.130	Ea	35.20	4.43	39.63



Landscaping

Craft@Hrs Unit Material Labor Total

Landscaping

Seeding, level area

Using tall fescue seed, per 20 lb bag	—	Ea	59.50	—	59.50
Seeding preparation, grade, rake, clean	BL@.003	SY	.12	.09	.21
Mechanical seeding (5 lbs per 1,000 SF)	BL@.002	MSF	14.90	.06	14.96
Hand seeding (10 lbs per 1,000 SF)	BL@.004	MSF	29.70	.12	29.82

Fertilizer, pre-planting,

24-nitrogen, 24-phosphorus, 4-potassium (3.34 lb per 1,000 SF)	BL@.222	MSF	11.50	6.78	18.28
Liming, pelletized (10 lbs per 1,000 SF)	BL@.222	MSF	0.84	6.78	7.62

Placing topsoil, delivered to site, 1 CY covers 81 SF at 4" depth. Add cost for equipment, where needed, from Excavation Equipment Costs section. Labor shown below is for operation of equipment.

With equipment, level site	BL@.092	CY	24.90	2.81	27.71
With equipment, sloped site	BL@.107	CY	24.90	3.27	28.17
By hand, level site	BL@.735	CY	24.90	22.50	47.40
By hand, sloped site	BL@.946	CY	24.90	28.90	53.80

Placing soil amendments, by hand spreading

Natural wood chip mulch	BL@1.27	CY	22.60	38.80	61.40
Forest mulch	BL@1.27	CY	62.20	38.80	101.00
Peat loam	BL@1.27	CY	56.50	38.80	95.30
Organic compost	BL@1.27	CY	52.00	38.80	90.80
Bale of straw, 25 bales per ton	BL@.200	Ea	4.00	6.11	10.11

Landscape stepping stones, concrete

12" round	BL@.133	Ea	3.67	4.06	7.73
14" round	BL@.133	Ea	4.94	4.06	9.00
18" round	BL@.153	Ea	8.54	4.67	13.21
24" round	BL@.153	Ea	14.50	4.67	19.17
Add for square shapes	—	%	20.0	—	—
18" or 24" diameter natural tree ring	BL@.133	Ea	3.09	4.06	7.15

Redwood benderboard, staked redwood

1/8" x 3-3/8" x 8'	BL@.011	LF	.25	.34	.59
1/8" x 3-3/8" x 14'	BL@.016	LF	.36	.49	.85
1/4" x 4" x 12'	BL@.016	LF	.33	.49	.82

Roto-tilling light soil

To 4" depth	BL@.584	CSY	—	17.80	17.80
-------------	---------	-----	---	-------	-------

Sodding, no soil preparation, nursery sod, Bermuda or Blue Rye mix

Per SF (500 SF minimum charge)	BL@.013	SF	.82	.40	1.22
--------------------------------	---------	----	-----	-----	------

Hydroseeding subcontract (spray application of seed, binder and fertilizer slurry). Costs will vary based upon site conditions, quality/type of seed. For areas greater than 10,000 SF, see the hydroseeding cost in the commercial section.

1,000 – 2,000 SF job	—	MSF	—	—	210.00
2,001 – 4,000 SF job	—	MSF	—	—	180.00
4,001 – 6,000 SF job	—	MSF	—	—	150.00
6,001 – 10,000 SF job	—	MSF	—	—	135.00

Lath

Gypsum lath, perforated or plain, 1/2" x 2' x 8' sheets. Add the cost of gypsum base and finish plaster, includes 10% for waste and fasteners.

On walls, nailed or stapled	BR@.090	SY	3.68	3.27	6.95
On walls, clipped	BR@.095	SY	3.83	3.45	7.28
On ceilings, nailed or stapled	BR@.125	SY	3.68	4.54	8.22
On ceilings, clipped	BR@.130	SY	3.83	4.72	8.55
Add soffits, arches	—	%	10.0	35.0	—



Lawn Sprinkler Systems

	Craft@Hrs	Unit	Material	Labor	Total
Steel lath, diamond pattern (junior mesh), 27" x 96" sheets, nailed to walls.					
1.75 pound	BR@.076	SY	2.15	2.76	4.91
2-1/2 pound, galvanized	BR@.076	SY	4.30	2.76	7.06
2-1/2 pounds, paper back, dimpled	BR@.076	SY	5.66	2.76	8.42
3.4 pounds, galvanized	BR@.076	SY	5.79	2.76	8.55
3.4 pounds, paper back	BR@.076	SY	5.56	2.76	8.32
3/8" hi rib, 29 gauge	BR@.076	SY	7.65	2.76	10.41
Add for ceiling applications	—	%	—	25.0	—
Galvanized stucco netting, 1-1/2" mesh, per roll, nailed to walls					
36" x 150', 20 gauge, roll	BR@2.80	Ea	61.30	102.00	163.30
36" x 150', 17-gauge, roll	BR@2.80	Ea	95.00	102.00	197.00
36" x 100', 17-gauge paper back	BR@2.80	Ea	98.00	102.00	200.00
6" x 50' stucco repair net	—	Ea	14.80	—	14.80
Corner bead, 26 gauge, 8' to 12' lengths.					
Expanded corner bead, 8' long	BR@.027	LF	.98	.98	1.96
Expanded corner bead, 10' long	BR@.027	LF	1.10	.98	2.08
Cornerite corner bead, 3" x 3" x 8'	BR@.027	LF	.41	.98	1.39
Cornerite plaster corner, 2" x 2" x 4'	BR@.027	LF	.89	.98	1.87
Cornerite stucco corner, 3" x 3" 8' long	BR@.027	LF	.66	.98	1.64
Short flange corner bead, 8' long	BR@.027	LF	1.57	.98	2.55
Plaster J-trim, 1-3/8" wide x 10' long	BR@.027	LF	.99	.98	1.97
Casing beads					
Short flange, 1/2" x 10' long	BR@.025	LF	.81	.91	1.72
Short flange, 7/8" x 10' long	BR@.025	LF	.81	.91	1.72
Expanded flange, 3/4" x 10'	BR@.025	LF	.51	.91	1.42
Expansion joint, 26 gauge, 1/2" ground	BR@.050	LF	2.83	1.82	4.65
Lawn Sprinkler Systems					
PVC Schedule 40 pipe laid in an open trench and connected. Add the cost of trenching, valves and sprinkler heads below.					
1/2" Schedule 40 PVC pressure pipe and fittings					
1/2" pipe	BL@.010	LF	.43	.31	.74
1/2" 90 degree ell	BL@.100	Ea	.50	3.06	3.56
1/2" tee	BL@.130	Ea	.59	3.97	4.56
3/4" Schedule 40 PVC pressure pipe and fittings					
3/4" pipe	BL@.012	LF	.51	.37	.88
3/4" 90 degree ell	BL@.115	Ea	.65	3.51	4.16
3/4" tee	BL@.140	Ea	.77	4.28	5.05
1" Schedule 40 PVC pressure pipe and fittings					
1" pipe	BL@.015	LF	.72	.46	1.18
1" 90 degree ell	BL@.120	Ea	1.26	3.67	4.93
1" tee	BL@.170	Ea	1.77	5.19	6.96
Deduct for Class 200 PVC pipe	—	%	-47.5	—	—
Trenching for sprinkler pipe installation, by hand, including backfill and tamp					
Light soil, 8" wide					
12" deep	BL@.027	LF	—	.82	.82
18" deep	BL@.040	LF	—	1.22	1.22
24" deep	BL@.053	LF	—	1.62	1.62
Average soil, 8" wide					
12" deep	BL@.043	LF	—	1.31	1.31
18" deep	BL@.065	LF	—	1.99	1.99
24" deep	BL@.087	LF	—	2.66	2.66

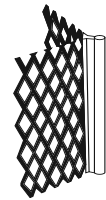
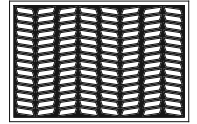





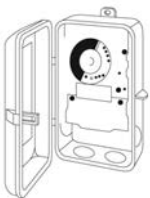
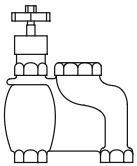
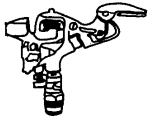

Lawn Sprinkler Systems

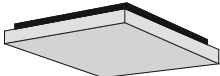
	Craft@Hrs	Unit	Material	Labor	Total
Heavy soil or loose rock, 8" wide					
12" deep	BL@.090	LF	—	2.75	2.75
18" deep	BL@.100	LF	—	3.06	3.06
24" deep	BL@.134	LF	—	4.09	4.09
Impact sprinkler heads, riser mounted, adjustable circle					
Brass	BL@.422	Ea	14.50	12.90	27.40
Plastic	BL@.422	Ea	7.67	12.90	20.57
Plastic, 3" pop-up	BL@.422	Ea	19.50	12.90	32.40
Gear drive rotor sprinkler, 3/4" inlet					
Adjustable, 30' radius	BL@.422	Ea	8.46	12.90	21.36
Spray head pop-up type, plastic					
2-1/2" height	BL@.056	Ea	3.36	1.71	5.07
4" height	BL@.056	Ea	5.51	1.71	7.22
6" height	BL@.056	Ea	9.64	1.71	11.35
Spray head, plastic with brass insert, for riser mounting					
Adjustable 0 to 330 degrees	BL@.056	Ea	3.05	1.71	4.76
Standard quarter, half or full pattern	BL@.056	Ea	1.71	1.71	3.42
Shrub spray, all patterns	BL@.056	Ea	3.97	1.71	5.68
Sprinkler head and riser, 1/2" PVC riser connected to branch supply with three threaded fittings and plastic 4" pop-up head					
4" riser	BL@.056	Ea	10.70	1.71	12.41
6" riser	BL@.056	Ea	10.90	1.71	12.61
12" riser	BL@.056	Ea	11.60	1.71	13.31
18" riser	BL@.056	Ea	11.80	1.71	13.51
24" riser	BL@.056	Ea	12.50	1.71	14.21
Valves, non-siphon, manual, brass					
3/4" valve	BL@1.03	Ea	35.70	31.50	67.20
1" valve	BL@1.38	Ea	31.10	42.20	73.30
Valves, electric solenoid, plastic, with pressure-assisted flow control, hookup but no wire included					
3/4" valve	BL@1.26	Ea	16.40	38.50	54.90
1" valve	BL@1.26	Ea	15.40	38.50	53.90
Valve control wire, 16 gauge low voltage plastic jacket direct burial cable, laid with pipe. No trenching or end connections included.					
2 conductor	BL@.003	LF	.14	.09	.23
3 conductor	BL@.003	LF	.20	.09	.29
5 conductor	BL@.003	LF	.35	.09	.44
7 conductor	BL@.003	LF	.51	.09	.60
8 conductor	BL@.003	LF	.52	.09	.61
Programmable irrigation control stations, no valve or wiring included, add electrical connection if required.					
For up to 6 electric valves	BL@1.83	LS	52.90	55.90	108.80
For up to 8 electric valves	BL@1.83	LS	64.90	55.90	120.80
Add for 120 volt receptacle	—	LS	—	—	140.00
Residential sprinkler system, typical labor and material costs for irrigating 1,700 SF using 400 LF of 3/4" Schedule 40 PVC pipe, 35 LF of 1" Schedule 40 PVC pipe, four electric 3/4" valves, pop-up sprinkler heads on 6" risers spaced 10', 100 LF of 5-conductor control wire and 235 LF of trenching 12" deep in average soil.					
Large or regular area, 30 heads	BL@.023	SF	.31	.70	1.01
Narrow or irregular area, 40 heads	BL@.025	SF	.37	.76	1.13
Add for freezing zones	—	SF	—	—	.12
Layout Foundation layout, medium to large size residence, 6 to 8 outside corners, includes shooting elevation from nearby reference, stakes and batterboards as required. No surveying or clearing included.					
Typical cost per residence	B1@7.86	LS	135.00	268.00	403.00

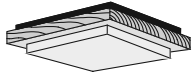
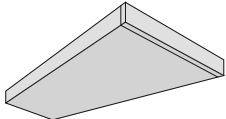
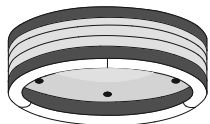

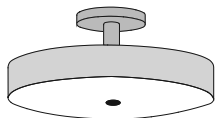
Lighting Fixtures

	Craft@Hrs	Unit	Material	Labor	Total	
Lighting Fixtures See also Electrical Work. Costs are to hang and connect fixtures only. Add the cost of wiring and fittings from the Commercial and Industrial section of this manual.						
Fluorescent lighting fixtures						
Surface mounted fluorescent fixtures, including ballasts but no lamps.						
Wraparound acrylic diffuser						
24", two 20 watt tubes	BE@1.60	Ea	32.00	65.60	97.60	
48", two 40 watt tubes	BE@1.60	Ea	48.90	65.60	114.50	
48", four 40 watt tubes	BE@1.60	Ea	131.00	65.60	196.60	
96" tandem, four 40 watt tubes	BE@1.60	Ea	133.00	65.60	198.60	
Low profile wraparound model						
10" x 48" x 4", two 20 watt tubes	BE@1.60	Ea	83.50	65.60	149.10	
15" x 48" x 4", four 40 watt tubes	BE@1.60	Ea	142.00	65.60	207.60	
15" x 96" x 4", eight 40 watt tubes	BE@1.60	Ea	219.00	65.60	284.60	
19" x 19" x 4", one 32/40 watt circline tube	BE@1.60	Ea	90.50	65.60	156.10	
24" x 24" x 4", two 40 watt U/6 tubes	BE@1.60	Ea	116.00	65.60	181.60	
Basic wraparound acrylic diffusers, solid oak wood ends						
10" x 24" x 3", two 20 watt tubes	BE@1.60	Ea	53.70	65.60	119.30	
10" x 48" x 3", two 40 watt tubes	BE@1.60	Ea	65.60	65.60	131.20	
Economy, wraparound acrylic diffuser, basic metal ends						
14" x 48" x 2", four 40 watt tubes	BE@1.60	Ea	98.30	65.60	163.90	
8" x 48" x 2", two 40 watt tubes	BE@1.60	Ea	53.70	65.60	119.30	
Electronic ballast troffer fixture, for mounting in a suspended ceiling						
Four 32 watt T8 tubes	BE@.900	Ea	56.70	36.90	93.60	
Four 32 watt T8 tubes, with flex connection	BE@.800	Ea	61.80	32.80	94.60	
Basic circular fixtures for circline tubes						
Simulated glass crystal with antiqued metal band,						
11" round x 3" high, one 22 watt tube	BE@.696	Ea	20.80	28.60	49.40	
Circular fixture						
12" round x 3" high, 22 and 32 watt tubes	BE@.696	Ea	28.60	28.60	57.20	
Fixture with frosted glass diffuser						
19" round x 4" high, 32 and 40 watt tubes	BE@.696	Ea	88.30	28.60	116.90	
Low profile rectangular wall or ceiling mount fixture, metal housing, white acrylic diffuser						
9-5/8" x 1-7/8", two 9 watt energy saver bulbs	BE@.696	Ea	50.70	28.60	79.30	
Rectangular indoor/outdoor model with discoloration resistant/impact resistant acrylic diffuser and cold weather ballast						
10" x 10" x 5" deep, one 22 watt tube	BE@.696	Ea	82.20	28.60	110.80	
12" x 12" x 5" deep, one 34 watt tube	BE@.696	Ea	106.00	28.60	134.60	
Hall lantern type, including tubes						
4-1/4" wide x 12-1/8" long x 4" deep	BE@.696	Ea	51.70	28.60	80.30	
Decorative valance type, with solid oak frame and acrylic diffuser.						
12" x 25" x 4", two 20 watt tubes	BE@2.06	Ea	104.00	84.50	188.50	
25" x 25" x 4", two 40 watt U/6 tubes	BE@1.59	Ea	131.00	65.20	196.20	
12" x 49" x 4", two 40 watt tubes	BE@1.59	Ea	120.00	65.20	185.20	
Economy valance type, with metal ends. Round or square models available						
All models are 2-5/8" wide x 4-1/4" deep						
24-3/4" L (requires one 15 watt tube)	BE@1.59	Ea	28.60	65.20	93.80	
24-3/4" L (requires one 20 watt tube)	BE@1.59	Ea	31.00	65.20	96.20	
36-3/4" L (requires one 30 watt tube)	BE@1.59	Ea	40.00	65.20	105.20	
36-3/4" L (requires two 30 watt tubes)	BE@1.59	Ea	48.60	65.20	113.80	
48-3/4" L (requires one 40 watt tube)	BE@1.59	Ea	54.80	65.20	120.00	
48-3/4" L (requires two 40 watt tubes)	BE@1.59	Ea	61.70	65.20	126.90	

Lighting Fixtures, Fluorescent

Craft@Hrs Unit Material Labor Total

Under shelf/cabinet type for wiring to wall switch

18" x 5" x 2", one 15 watt tube	BE@.696	Ea	20.60	28.60	49.20
24" x 5" x 2", one 20 watt tube	BE@.696	Ea	27.50	28.60	56.10
36" x 5" x 2", one 30 watt tube	BE@.696	Ea	42.70	28.60	71.30
48" x 5" x 2", one 40 watt tube	BE@.696	Ea	60.10	28.60	88.70

Fluorescent tubes, carton quantities

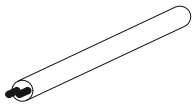

T8 (1" diameter) tubes, universal start except as noted

15 watt, 18", preheat	BE@.035	Ea	3.29	1.44	4.73
17 watt, 24", #735	BE@.035	Ea	2.45	1.44	3.89
25 watt, 36", #835	BE@.035	Ea	4.79	1.44	6.23
28 watt, 40", #830	BE@.035	Ea	4.32	1.44	5.76
25 watt, 48", #ADV835	BE@.035	Ea	4.24	1.44	5.68
32 watt, 48", cool white	BE@.035	Ea	2.60	1.44	4.04
40 watt, 60", #865	BE@.035	Ea	6.60	1.44	8.04
58 watt, 60", #841	BE@.035	Ea	8.84	1.44	10.28
38 watt, 72", cool white	BE@.070	Ea	13.40	2.87	16.27
59 watt, 96", cool white	BE@.070	Ea	8.62	2.87	11.49

T12 (1-1/2" diameter) tubes, cool white

20 watt, 24"	BE@.035	Ea	3.82	1.44	5.26
30 watt, 36"	BE@.035	Ea	3.30	1.44	4.74
39 watt, 48"	BE@.035	Ea	5.76	1.44	7.20
56 watt, 72"	BE@.070	Ea	4.73	2.87	7.60
70 watt, 84"	BE@.070	Ea	7.01	2.87	9.88
75 watt, 96"	BE@.070	Ea	12.00	2.87	14.87

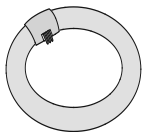

Circular (circline) tubes, T9 (1-1/8" diameter)

22 watt, 8" diameter	BE@.035	Ea	3.64	1.44	5.08
32 watt, 12" diameter	BE@.035	Ea	4.03	1.44	5.47
40 watt, 16" diameter	BE@.035	Ea	4.35	1.44	5.79

U-shaped tubes



31 watt, 22-1/2" long, 1-5/8" gap, T8	BE@.035	Ea	8.05	1.44	9.49
32 watt, 22-1/2" long, 6" gap, T8	BE@.035	Ea	7.25	1.44	8.69
40 watt, 22-1/2" long, 6" gap, T12	BE@.035	Ea	9.35	1.44	10.79
48 watt, 22-1/2" long, 6" gap, T12, high output (sign bulb)	BE@.070	Ea	47.90	2.87	50.77

Screw-base light fixtures

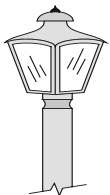

Outdoor post lantern fixtures, antique satin brass finish, no digging included

Post lantern type fixture, cast aluminum	BE@2.00	Ea	80.00	82.10	162.10
--	---------	----	-------	-------	--------

Modern porch ceiling fixture

7-1/2" x 7-1/2" x 3" drop, single light	BE@2.15	Ea	31.70	88.20	119.90
---	---------	----	-------	-------	--------

Flood light lampholders

Cadmium steel plate	BE@2.15	Ea	37.50	88.20	125.70
---------------------	---------	----	-------	-------	--------

1/2" male swivel 7-5/16" long, aluminum	BE@2.15	Ea	35.90	88.20	124.10
---	---------	----	-------	-------	--------

Path lighting, kits with cable and timer

20 light low voltage	BE@2.63	LS	71.20	108.00	179.20
----------------------	---------	----	-------	--------	--------

6 flood lights, 11 watt	BE@2.98	LS	75.60	122.00	197.60
-------------------------	---------	----	-------	--------	--------

12 tier lights, 7 watt, programmable	BE@2.63	LS	102.00	108.00	210.00
--------------------------------------	---------	----	--------	--------	--------

Recessed fixtures, including housing, screw base

Integral thermally protected recessed (can) light housing

4" recessed light housing, non-insulated	BE@1.00	Ea	22.20	41.00	63.20
--	---------	----	-------	-------	-------

5" recessed light housing, non-insulated	BE@1.00	Ea	28.20	41.00	69.20
--	---------	----	-------	-------	-------

6" recessed light housing, non-insulated	BE@1.00	Ea	14.20	41.00	55.20
--	---------	----	-------	-------	-------

Add for insulated housing	—	%	25.0	—	—
---------------------------	---	---	------	---	---

Add for low voltage	—	%	101.00	—	—
---------------------	---	---	--------	---	---

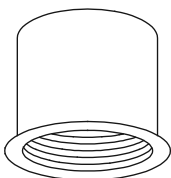

Lighting Fixture, Screw-base

	Craft@Hrs	Unit	Material	Labor	Total
Recessed baffle light trim	BE@0.25	Ea	12.90	10.30	23.20
Recessed flat light trim	BE@0.25	Ea	12.90	10.30	23.20
Recessed eyeball light trim	BE@0.25	Ea	42.30	10.30	52.60
Recessed reflector light trim	BE@0.25	Ea	18.30	10.30	28.60
Recessed shower light trim	BE@0.25	Ea	17.10	10.30	27.40
Recessed open light trim	BE@0.25	Ea	5.64	10.30	15.94
Recessed adjustable light trim	BE@0.25	Ea	32.00	10.30	42.30
Recessed splay light trim	BE@0.25	Ea	14.10	10.30	24.40
Utility 12" x 10", diffusing glass lens	BE@1.00	Ea	62.80	41.00	103.80
Ceiling fixtures, 60 watt max bulb, pre-wired housing, white, canopy finish					
Cloud 9-3/4" x 5-1/4" (2 bulbs)	BE@1.59	Ea	33.40	65.20	98.60
Cloud 8-1/4" x 5-1/2" (1 bulb)	BE@1.59	Ea	42.30	65.20	107.50
Standard globe 8-3/4" x 5" (2 bulbs)	BE@1.59	Ea	29.10	65.20	94.30
Cloud globe, brass canopy 10" x 5"	BE@1.59	Ea	36.10	65.20	101.30

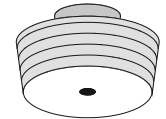
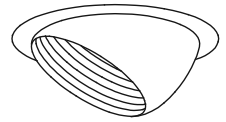

Screw-base light bulbs Case quantities.

Compact fluorescent (CFL)

14 watt, 60-watt equivalent	BE@.035	Ea	1.99	1.44	3.43
23 watt, 100-watt equivalent	BE@.035	Ea	1.99	1.44	3.43
42 watt, 200-watt equivalent	BE@.035	Ea	8.38	1.44	9.82
65 watt, 300-watt equivalent	BE@.035	Ea	17.40	1.44	18.84
85 watt, 400-watt equivalent	BE@.035	Ea	26.40	1.44	27.84
105 watt, 500-watt equivalent	BE@.035	Ea	22.60	1.44	24.04
15 watt, 65 watt equivalent, dimmable flood	BE@.035	Ea	3.11	1.44	4.55

Light emitting diode bulbs (LED)

9.5 watt A19 (60W) daylight	BE@.035	Ea	2.69	1.44	4.13
13 watt flood, PAR30 equivalent	BE@.035	Ea	9.96	1.44	11.40
20 watt flood, PAR38 equivalent	BE@.035	Ea	8.49	1.44	9.93
22 watt A21 (100W) soft white	BE@.035	Ea	7.67	1.44	9.11

Log Home Construction

Logs are cut from standing dead lodgepole pine or spruce. Add the foundation cost. Based on Authentic Log Homes.

Rule of thumb cost, including labor, material and hardware but no foundation, plumbing, HVAC, electrical work or interior finishing. The finished cost of a log home will usually be about 25% more than the equivalent conventional home.

Total cost per square foot of wall (shell only)	—	SF	—	—	40.20
Lodgepole pine or spruce logs, including local delivery, per LF of log at 8" to 12" diameter					
8" machine peeled	—	LF	15.80	—	15.80
8" hand peeled	—	LF	16.80	—	16.80
10" machine peeled	—	LF	21.10	—	21.10
10" hand peeled	—	LF	23.40	—	23.40
12" machine peeled	—	LF	27.40	—	27.40
12" hand peeled	—	LF	29.80	—	29.80

Labor costs for log home construction. Using a crew experienced in log home construction. Add 10% to 50% for crews on their first log home project. Subfloor and porch joist hardware uses Type B Simpson Strong-Tie hangers. These labor estimates assume precut 8" x 6" log profiles. For 9" x 7" profiles, add 10%. For 10" x 8" profiles, add 20%. For random length logs, add 10%. The preferred crew is three carpenters and three helpers.

Subfloor

CCA treated sill plate, anchor bolts.	B1@.057	LF	—	1.94	1.94
Built-up girders (using 2 x 8 lumber)	B1@.222	LF	—	7.57	7.57
Posts (8" log), with anchor	B1@.500	Ea	—	17.10	17.10
Rim joists and blocking (2 x 8)	B1@.065	LF	—	2.22	2.22
Floor joists (2 x 8), hangers, bridging/blocking	B1@.025	LF	—	.85	.85
Decking	B1@.014	SF	—	.48	.48

Log Home Construction

	Craft@Hrs	Unit	Material	Labor	Total
Porch					
Rim joists	B1@.017	LF	—	.58	.58
Posts (8" log), with anchor	B1@.500	Ea	—	17.10	17.10
Joists with hangers	B1@.025	SF	—	.85	.85
Decking (2 x 6 redwood)	B1@.025	SF	—	.85	.85
Balcony railing	B1@.125	LF	—	4.26	4.26
Sill log					
Flashing	B1@.010	LF	—	.34	.34
Sill log spiked onto subfloor	B1@.050	LF	—	1.71	1.71
Laying wall courses					
Courses 2 through 8	B1@.025	LF	—	.85	.85
Courses 9 through 16	B1@.033	LF	—	1.13	1.13
Course 17 (sill log)	B1@.040	LF	—	1.36	1.36
Courses 18 through 24	B1@.040	LF	—	1.36	1.36
Courses 25 through 32	B1@.050	LF	—	1.71	1.71
Doors and windows, per opening					
Interior trim	B1@2.00	Ea	—	68.20	68.20
Exterior trim	B1@2.00	Ea	—	68.20	68.20
Mantle (10 feet long)					
With bracing	B1@1.50	Ea	—	51.20	51.20
Log floor system					
Girder	B1@.050	LF	—	1.71	1.71
Support posts	B1@.500	Ea	—	17.10	17.10
Support wall (studs, top and bottom plates)	B1@.167	LF	—	5.70	5.70
Cutting wall notch to accept girder	B1@1.50	Ea	—	51.20	51.20
Floor joists	B1@.063	LF	—	2.15	2.15
Cutting wall notch to accept floor joist	B1@.500	Ea	—	17.10	17.10
T&G decking	B1@.025	SF	—	.85	.85
Log staircase					
Straight	B1@30.0	Ea	—	1,020.00	1,020.00
"L"- or "U"-shaped	B1@36.0	Ea	—	1,230.00	1,230.00
Wall stiffener					
6" x 6" or 8" x 8" beam channeled into wall	B1@2.00	Ea	—	68.20	68.20
Log rafter system, including dormers					
Ridge beam, main and secondary	B1@0.25	LF	—	8.53	8.53
Notching gable to accept ridge beam	B1@1.50	Ea	—	51.20	51.20
Built up truss pocket	B1@2.00	Ea	—	68.20	68.20
Valley beam layout and installation	B1@0.33	LF	—	11.30	11.30
Ridge beam support post	B1@0.50	Ea	—	17.10	17.10
Rafter 20' or less	B1@1.00	Ea	—	34.10	34.10
Rafter over 20'	B1@1.50	Ea	—	51.20	51.20
Valley rafter 16' or less	B1@1.50	Ea	—	51.20	51.20
Valley rafter between 16' and 20'	B1@2.00	Ea	—	68.20	68.20
Valley rafter over 20'	B1@2.50	Ea	—	85.30	85.30
Timber rafter 18' or less	B1@3.00	Ea	—	102.00	102.00
Timber rafter over 18'	B1@4.00	Ea	—	136.00	136.00
Rafter layout	B1@.250	Ea	—	8.53	8.53
Snow block	B1@1.00	Ea	—	34.10	34.10
Log trusses, 32' and less					
Hardware plate	B1@2.00	Ea	—	68.20	68.20
Collar ties	B1@1.00	Ea	—	34.10	34.10
Vertical or diagonal web	B1@3.00	Ea	—	102.00	102.00
Add for each 5' of truss over 32'	—	%	—	50.0	—

Lumber, Framing

	Craft@Hrs	Unit	Material	Labor	Total
Cold roof construction					
Secondary rafters	B1@0.50	Ea	—	17.10	17.10
Jack rafters	B1@0.25	Ea	—	8.53	8.53
Fly rafters	B1@0.50	Ea	—	17.10	17.10
Blocking	B1@0.25	Ea	—	8.53	8.53
OSB roof sheathing					
Less than or equal to 6/12 pitch	B1@1.72	Sq	—	58.70	58.70
7/12 pitch to 9/12 pitch	B1@2.00	Sq	—	68.20	68.20
Less than or equal to 6/12 pitch	B1@2.50	Sq	—	85.30	85.30
Felt	B1@1.00	Sq	—	34.10	34.10
Asphalt shingles	B1@2.00	Sq	—	68.20	68.20
Metal roof, ridge cap and closure strips	B1@1.33	Sq	—	45.40	45.40
Ridge vents and soffit vents	B1@3.00	Ea	—	102.00	102.00
Fascia	B1@0.02	LF	—	.68	.68
Soffit	B1@0.03	SF	—	1.02	1.02
Caulking					
Exterior only	B1@0.02	SF	—	.68	.68
Preservative					
Exterior only	B1@.005	SF	—	.17	.17
Electrical chases					
Cut in log ends and down tops of rafters	B1@.083	LF	—	2.83	2.83
Holes drilled through ridge beams	B1@0.50	Ea	—	17.10	17.10

Unit MBF 8' L 12' L 16' L

Framing Lumber

MBF means per 1,000 board feet. One board foot is the volume of lumber in a nominal 1" x 12" board one foot long. A 2" x 6" joist 10 feet long has 10 board feet. To determine the board feet of lumber in any piece, multiply the width in inches by the depth in inches by the length in feet. Then divide by 12.

Douglas fir – #2 & Better

2" x 4" – Green	Ea	1,210.00	6.46	9.69	12.90
2" x 6" – KD	Ea	1,520.00	12.10	18.20	24.30
2" x 8" – KD	Ea	1,170.00	12.50	18.80	25.00
2" x 10" – KD	Ea	1,420.00	18.90	28.40	37.90
2" x 12" – KD	Ea	1,530.00	24.60	36.80	49.10

Douglas fir – kiln dried Standard & Better

2" x 4"	Ea	1,390.00	7.39	11.10	14.80
2" x 6"	Ea	1,420.00	11.40	17.10	22.80
2" x 8"	Ea	1,260.00	13.50	20.20	27.00
2" x 10"	Ea	1,290.00	17.20	25.70	34.30
2" x 12"	Ea	1,340.00	21.40	32.10	42.80

Douglas fir finish and clear – C & Better, vertical grain, S4S, dry. West Coast prices. Add 10% to 30% for transportation to other areas

2" x 2"	Ea	4,140.00	10.30	15.60	20.80
2" x 3"	Ea	4,200.00	15.60	23.20	31.30
2" x 4"	Ea	4,650.00	23.20	35.10	46.90
2" x 6"	Ea	5,190.00	39.20	58.80	78.40
2" x 10"	Ea	7,290.00	92.10	139.00	183.00
2" x 12"	Ea	9,860.00	143.00	215.00	285.00

Douglas fir finish and clear – C & Better, flat grain, S4S, dry. West Coast prices. Add 10% to 30% for transportation to other areas

2" x 2"	Ea	4,010.00	10.30	15.60	20.80
2" x 3"	Ea	4,010.00	15.10	22.70	30.10
2" x 4"	Ea	4,040.00	20.50	30.60	40.70

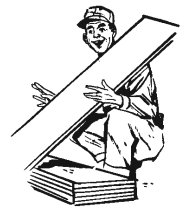

Lumber, Framing

	Unit	MBF	8' L	12' L	16' L
2" x 6"	Ea	4,680.00	35.40	53.10	70.80
2" x 8"	Ea	4,680.00	47.40	70.80	94.10
2" x 10"	Ea	4,690.00	59.00	88.40	118.00
2" x 12"	Ea	6,220.00	94.00	142.00	186.00
Hemlock/fir, kiln dried					
2" x 4" – Standard & Better	Ea	1,170.00	6.22	9.33	12.40
2" x 6" – #2 & Better	Ea	1,290.00	10.30	15.50	20.70
2" x 8" – #2 & Better	Ea	1,320.00	14.00	21.10	27.00
2" x 10" – #2 & Better	Ea	1,350.00	18.10	27.10	36.10
2" x 12" – #2 & Better	Ea	1,510.00	24.20	36.30	48.40
Spruce pine fir (SPF), kiln dried					
2" x 4", #2 and Better	Ea	1,390.00	7.38	11.10	14.80
2" x 6", #2 and Better	Ea	1,470.00	11.70	17.60	23.50
2" x 8", #2 and Better	Ea	825.00	8.80	13.20	17.60
2" x 10", #2 and Better	Ea	1,120.00	15.00	22.50	30.00
2" x 12", #2 and Better	Ea	1,330.00	21.30	31.90	42.60
2" x 4", Standard and Better	Ea	1,290.00	6.89	10.30	13.80
4" x 4", Standard and Better	Ea	1,440.00	15.30	23.00	30.60
Red cedar – green S4S					
2" x 4"	Ea	3,910.00	20.90	31.30	41.70
2" x 6"	Ea	4,550.00	36.40	54.70	72.90
Red cedar – green – D and Better S4S					
2" x 2"	Ea	7,290.00	19.40	29.10	38.80
2" x 4"	Ea	9,010.00	48.10	72.10	96.20
2" x 6"	Ea	6,180.00	49.40	74.10	98.80
Red cedar – rough – Standard and Better					
2" x 2"	Ea	4,230.00	11.30	16.90	22.60
2" x 4"	Ea	3,640.00	19.40	29.10	38.80
2" x 6"	Ea	4,190.00	33.60	50.30	67.10
2" x 8"	Ea	5,700.00	60.80	91.20	122.00
Southern yellow pine – #1 S4S					
2" x 4"	Ea	1,540.00	8.21	12.30	16.40
2" x 6"	Ea	1,270.00	10.20	15.30	20.40
2" x 10"	Ea	1,170.00	15.60	23.50	31.30
2" x 12"	Ea	1,410.00	22.60	33.90	45.20
Southern yellow pine – #2 S4S					
2" x 4"	Ea	996.00	5.31	7.96	10.60
2" x 6"	Ea	998.00	7.98	12.00	16.00
2" x 8"	Ea	1,120.00	12.00	18.00	24.00
2" x 10"	Ea	936.00	12.50	18.70	25.00
2" x 12"	Ea	1,120.00	18.00	26.90	35.90
Southern yellow pine – Prime S4S					
2" x 4"	Ea	908.00	4.84	7.26	9.68
2" x 6"	Ea	833.00	6.66	9.99	13.30
2" x 8"	Ea	933.00	9.95	14.90	19.90
2" x 10"	Ea	995.00	13.30	19.90	26.50
2" x 12"	Ea	1,220.00	19.60	29.40	39.20
Redwood. West Coast prices. Add 10% to 30% for transportation to other areas.					
2" x 2" – B Grade S4S	Ea	3,750.00	9.99	15.00	20.00
2" x 2" – Green	Ea	2,420.00	6.45	9.68	12.90
2" x 3" – Green	Ea	2,180.00	8.71	13.10	17.40
2" x 4" – Construction Common	Ea	2,680.00	14.30	21.40	28.60
2" x 6" – Construction Common	Ea	2,130.00	17.00	25.60	34.10
2" x 4" – Construction Rough	Ea	3,170.00	16.90	25.40	33.80

Lumber, Boards

	Unit	MBF	8' L	12' L	16' L
2" x 4" – Common S4S	Ea	2,800.00	14.90	22.40	29.80
2" x 6" – Common S4S	Ea	2,660.00	21.30	32.00	42.60
2" x 8" – Common S4S	Ea	2,930.00	31.30	46.90	62.60
2" x 12" – Common S4S	Ea	2,750.00	44.10	66.10	88.10
2" x 4" – Construction Heart, Rough	Ea	3,290.00	17.50	26.30	35.10
2" x 6" – Construction Heart, Rough	Ea	2,480.00	19.90	29.80	39.70
2" x 4" – Construction Heart, S4S	Ea	3,710.00	19.80	29.70	39.50
2" x 6" – Construction Heart, S4S	Ea	3,490.00	27.90	41.80	55.80
2" x 8" – Construction Heart, S4S	Ea	3,690.00	39.40	59.10	78.80
2" x 12" – Construction Heart, S4S	Ea	4,240.00	67.90	102.00	136.00

	Craft@Hrs	Unit	Material	Labor	Total
--	-----------	------	----------	-------	-------

Studs Typical costs for pre-cut white wood studding material, stud grade. Nominal sizes. Actual width and depth are about 1/2" less when dry. White wood species includes Engelmann spruce, all true firs, hemlocks and pines (excluding Ponderosa pine).

2" x 3" x 84"	B1@.192	Ea	5.10	6.55	11.65
2" x 4" x 84"	B1@.196	Ea	4.92	6.69	11.61
2" x 4" x 88"	B1@.200	Ea	6.46	6.82	13.28
2" x 4" x 92-5/8"	B1@.216	Ea	6.05	7.37	13.42
2" x 4" x 96"	B1@.224	Ea	6.07	7.64	13.71
2" x 4" x 104-5/8"	B1@.230	Ea	6.79	7.85	14.64
2" x 6" x 92-5/8"	B1@.308	Ea	10.40	10.50	20.90

	Unit	MBF	8' L	12' L	16' L
--	------	-----	------	-------	-------

Boards

Douglas fir finish and clear – C & Better (V/G) S4S, dry, vertical grain. West Coast prices. Add 10% to 30% for transportation to other areas.

1" x 2"	Ea	8,020.00	10.70	16.00	21.60
1" x 3"	Ea	8,020.00	16.00	24.10	32.40
1" x 4"	Ea	7,820.00	21.60	32.40	43.20
1" x 6"	Ea	9,140.00	36.70	54.60	72.80
1" x 8"	Ea	11,200.00	59.70	88.80	119.00
1" x 10"	Ea	12,400.00	82.80	124.00	161.00
1" x 12"	Ea	13,200.00	106.00	158.00	211.00

Douglas fir finish and clear – C & Better (F/G) S4S, dry, flat grain. West Coast prices. Add 10% to 30% for transportation to other areas.

1" x 2"	Ea	6,930.00	9.21	13.70	18.40
1" x 3"	Ea	6,930.00	13.90	20.80	27.60
1" x 4"	Ea	6,930.00	18.40	27.60	36.80
1" x 6"	Ea	7,240.00	29.00	43.50	57.80
1" x 8"	Ea	9,310.00	49.70	74.40	99.50
1" x 10"	Ea	13,000.00	86.20	130.00	172.00
1" x 12"	Ea	13,200.00	106.00	158.00	211.00

Southern yellow pine boards – C & Better

1" x 4"	Ea	2,930.00	7.82	11.70	15.60
1" x 6"	Ea	3,290.00	13.20	19.80	26.30
1" x 8"	Ea	3,700.00	19.70	29.60	39.50
1" x 12"	Ea	4,030.00	32.30	48.40	64.50

White pine boards, Select

1" x 4"	Ea	3,740.00	9.97	15.00	19.90
1" x 6"	Ea	4,980.00	19.90	29.90	39.80
1" x 8"	Ea	4,310.00	23.00	34.50	46.00
1" x 10"	Ea	4,500.00	30.00	45.00	60.00
1" x 12"	Ea	4,840.00	38.70	58.10	77.50

Lumber, Boards

	Unit	MBF	8' L	12' L	16' L
Eastern pine boards – Premium					
1" x 4"	Ea	2,180.00	5.81	8.72	11.60
1" x 6"	Ea	2,120.00	8.47	12.70	17.00
1" x 8"	Ea	1,650.00	8.80	13.20	17.60
1" x 10"	Ea	1,780.00	11.90	17.80	23.70
1" x 12"	Ea	2,350.00	18.80	28.30	37.70
Southern yellow pine flooring – D Grade					
1" x 4"	Ea	1,580.00	4.22	6.34	8.51
1" x 6"	Ea	1,800.00	7.11	10.70	14.10
1" x 8"	Ea	1,740.00	9.37	12.80	18.60
1" x 10"	Ea	1,590.00	10.70	14.10	21.20
1" x 12"	Ea	2,030.00	16.10	24.20	32.50
Fir flooring – C & Better tongue & groove					
1" x 3" vertical grain, C and Better	Ea	5,560.00	11.10	16.70	22.20
1" x 4" vertical grain, C and Better	Ea	5,560.00	14.90	22.20	29.90
1" x 3" flat grain, C and Better	Ea	3,350.00	6.69	10.00	13.40
1" x 4" flat grain, C and Better	Ea	3,350.00	8.90	13.40	17.80
1" x 3" vertical grain, D and Better	Ea	3,980.00	8.02	12.00	15.80
1" x 4" vertical grain, D and Better	Ea	3,980.00	10.70	15.80	20.60
1" x 3" flat grain, D and Better	Ea	2,670.00	5.23	7.92	10.50
1" x 4" flat grain, D and Better	Ea	2,610.00	7.03	10.50	14.00
Ponderosa pine boards – #4 & Better					
1" x 3"	Ea	3,920.00	7.85	11.80	15.70
1" x 4"	Ea	3,490.00	9.28	13.90	18.60
1" x 6"	Ea	3,590.00	14.40	21.50	28.70
1" x 8"	Ea	3,560.00	19.00	28.40	37.90
1" x 10"	Ea	4,030.00	26.90	40.30	53.70
White wood boards – Appearance Grade					
1" x 4"	Ea	3,590.00	9.56	14.30	19.10
1" x 6"	Ea	3,860.00	15.50	23.20	30.90
1" x 8"	Ea	3,930.00	20.90	31.40	41.80
1" x 12"	Ea	4,910.00	39.20	58.90	78.50
Cypress boards					
1" x 4"	Ea	3,150.00	8.39	12.60	16.80
1" x 6"	Ea	3,810.00	15.20	22.80	30.50
1" x 8"	Ea	4,260.00	22.70	34.10	45.40
1" x 10"	Ea	4,320.00	28.80	43.20	57.60
1" x 12"	Ea	5,000.00	39.90	59.90	79.80
Hemlock boards – C & Better					
1" x 2"	Ea	5,800.00	7.74	11.60	15.50
1" x 3"	Ea	6,030.00	12.10	18.10	24.10
1" x 4"	Ea	6,170.00	16.40	24.60	32.90
1" x 6"	Ea	7,790.00	31.10	46.70	62.30
Pine boards – Select					
1" x 2"	Ea	3,960.00	5.28	7.92	10.60
1" x 3"	Ea	4,020.00	8.03	12.10	16.10
Clear Douglas fir – S4S					
1" x 2"	Ea	6,210.00	8.28	12.40	16.60
1" x 3"	Ea	6,330.00	12.70	19.00	25.30
1" x 4"	Ea	7,260.00	19.30	29.00	38.70
1" x 6"	Ea	8,570.00	34.30	51.40	68.60
1" x 8"	Ea	7,350.00	39.20	58.80	78.40

Lumber, Boards

	Unit	MBF	8' L	12' L	16' L
Douglas fir / hemlock					
1" x 4"	Ea	2,210.00	5.89	8.84	11.80
1" x 6"	Ea	2,370.00	9.48	14.20	19.00
Southern yellow pine premium decking					
5/4" x 6"	Ea	3,270.00	16.40	24.50	32.70

	Unit	6' L	8' L	12' L	16' L
Red oak boards, S4S, East Coast and Midwest prices					
1" x 2"	Ea	7.21	9.60	12.40	14.70
1" x 3"	Ea	11.00	19.80	27.10	32.60
1" x 6"	Ea	22.80	30.30	40.10	47.90
1" x 8"	Ea	30.00	39.80	54.10	71.80
1" x 10"	Ea	44.40	60.00	74.00	88.70
1" x 12"	Ea	53.40	66.90	94.30	113.00

	Unit	MBF	8' L	12' L	16' L
Cedar boards – S1S2E (surfaced 1 side, 2 ends)					
3/4" x 2"	Ea	6,020.00	6.02	9.03	12.00
3/4" x 4"	Ea	5,050.00	10.10	15.20	20.20
3/4" x 6"	Ea	8,600.00	25.80	38.70	51.60
7/8" x 4"	Ea	6,660.00	15.60	23.30	31.10
7/8" x 6"	Ea	9,360.00	32.80	49.20	65.50
7/8" x 8"	Ea	7,640.00	35.70	53.50	71.30
7/8" x 10"	Ea	7,780.00	45.40	68.10	90.80
7/8" x 12"	Ea	8,360.00	58.50	87.80	117.00
1" x 4"	Ea	6,570.00	17.50	26.20	35.00
1" x 6"	Ea	8,130.00	32.50	48.80	65.00
Clear cedar trim boards					
1" x 2"	Ea	4,980.00	6.65	9.97	13.30
1" x 3"	Ea	7,280.00	14.60	21.90	29.10
1" x 4"	Ea	10,400.00	27.80	41.70	55.60
1" x 6"	Ea	15,700.00	62.70	94.10	125.00
1" x 8"	Ea	20,900.00	112.00	167.00	223.00
Red cedar boards, kiln dried					
1" x 4"	Ea	3,550.00	9.44	14.20	18.90
1" x 6"	Ea	3,950.00	15.80	23.70	31.60
1" x 8"	Ea	4,610.00	24.60	36.90	49.20

Redwood boards, West Coast prices.

Add 10% to 30% for transportation to other areas.

1" x 2" – B Grade S4S	Ea	5,180.00	6.91	10.40	13.80
1" x 3" – B Grade S4S	Ea	5,030.00	10.10	15.10	20.10
1" x 4" – B Grade S4S	Ea	5,860.00	15.60	23.40	31.20
1" x 6" – B Grade S4S	Ea	5,660.00	22.70	34.00	45.30
1" x 4" – Green	Ea	3,740.00	9.97	15.00	19.90
1" x 6" – Green	Ea	5,450.00	21.80	32.70	43.60
1" x 8" – Select S1S2E	Ea	3,640.00	19.40	29.10	38.80

	Craft@Hrs	Unit	Material	Labor	Total
--	-----------	------	----------	-------	-------

Lath, Redwood "A" & Better, 50 per bundle, nailed to walls for architectural treatment.

5/16" x 1-1/2" x 4"	BC@.500	Bdle	26.00	18.80	44.80
5/16" x 1-1/2" x 6"	BC@.625	Bdle	34.90	23.50	58.40
5/16" x 1-1/2" x 8"	BC@.750	Bdle	48.60	28.20	76.80

Lumber, Siding

Craft@Hrs Unit Material Labor Total

Board Siding

Pine bevel siding, 1/2" thick by 6" wide. Each linear foot of 6" wide bevel siding covers .38 square feet of wall. Do not deduct for wall openings less than 10 square feet. Add 5% for typical waste and end cutting.

8' lengths	B1@.038	SF	1.27	1.30	2.57
12' lengths	B1@.036	SF	1.25	1.23	2.48
16' lengths	B1@.033	SF	1.28	1.13	2.41

Western red cedar bevel siding. A Grade and Better, 1/2" thick by 6" wide. Each linear foot of 6" wide bevel siding covers .38 square feet of wall. Do not deduct for wall openings less than 10 square feet. Add 5% for typical waste and end cutting.

8' lengths	B1@.038	SF	11.40	1.30	12.70
12' lengths	B1@.036	SF	11.10	1.23	12.33
16' lengths	B1@.033	SF	11.40	1.13	12.53

Clear cedar 1/2" bevel siding. Vertical grain, 1/2" thick by 6" wide, kiln dried. Each linear foot of 6" wide bevel siding covers .38 square feet of wall. Do not deduct for wall openings less than 10 square feet. Add 5% for typical waste and end cutting.

8' lengths	B1@.038	SF	11.60	1.30	12.90
12' lengths	B1@.036	SF	11.70	1.23	12.93
16' lengths	B1@.033	SF	11.80	1.13	12.93

Cedar 3/4" bevel siding, 3/4" thick by 8" wide. Each linear foot of 8" wide bevel siding covers .54 square feet of wall. Do not deduct for wall openings less than 10 square feet. Add 5% for typical waste and end cutting.

8' lengths	B1@.036	SF	6.04	1.23	7.27
12' lengths	B1@.034	SF	5.97	1.16	7.13
16' lengths	B1@.031	SF	6.08	1.06	7.14

Rustic cedar channel siding, 3/4" x 8". Each linear foot of 8" wide channel siding covers .54 square feet of wall. Do not deduct for wall openings less than 10 square feet. Add 5% for typical waste and end cutting.

12' lengths	B1@.034	SF	9.01	1.16	10.17
-------------	---------	----	------	------	-------

Tongue and groove cedar siding, 1" x 6". Kiln dried, select. Each linear foot of 6" wide tongue and groove siding covers 0.43 square feet of wall. Do not deduct for wall openings less than 10 square feet. Add 5% for typical waste and end cutting.

8' lengths	B1@.036	SF	9.62	1.23	10.85
10' lengths	B1@.035	SF	7.94	1.19	9.13
12' lengths	B1@.034	SF	8.60	1.16	9.76

Redwood 5/8" tongue and groove siding, 5/8" thick by 5-3/8" wide. Each linear foot of 5-3/8" wide tongue and groove siding covers 0.42 square feet of wall. Do not deduct for wall openings less than 10 square feet. Add 5% for typical waste and end cutting.

8' lengths	B1@.042	SF	5.31	1.43	6.74
10' lengths	B1@.040	SF	6.39	1.36	7.75
12' lengths	B1@.038	SF	6.52	1.30	7.82

Redwood 5/8" shiplap siding, B Grade. 5/8" thick by 5-3/8" wide. Each linear foot of 5-3/8" wide shiplap siding covers 0.38 square feet of wall. Do not deduct for wall openings less than 10 square feet. Add 5% for typical waste and end cutting.

8' lengths	B1@.038	SF	7.23	1.30	8.53
10' lengths	B1@.037	SF	7.22	1.26	8.48
12' lengths	B1@.036	SF	7.21	1.23	8.44

Southern yellow pine, 6" pattern 105 siding, 1" x 6". Select Grade except as noted. Each linear foot of 6" wide siding covers 0.38 square feet of wall. Do not deduct for wall openings less than 10 square feet. Add 5% for typical waste and end cutting.

8' lengths	B1@.038	SF	4.59	1.30	5.89
10' lengths	B1@.037	SF	4.66	1.26	5.92
12' lengths, No. 2	B1@.036	SF	2.62	1.23	3.85
12' lengths	B1@.036	SF	4.62	1.23	5.85

Lumber, Siding

	Craft@Hrs	Unit	Material	Labor	Total
Southern yellow pine, 8" pattern 105 siding, 1" x 8". Select Grade except as noted. Each linear foot of 8" wide siding covers 0.54 square feet of wall. Do not deduct for wall openings less than 10 square feet. Add 5% for typical waste and end cutting.					
8' lengths	B1@.036	SF	4.25	1.23	5.48
10' lengths	B1@.034	SF	4.11	1.16	5.27
12' lengths, No. 2	B1@.031	SF	2.10	1.06	3.16
12' lengths	B1@.031	SF	4.09	1.06	5.15
Southern yellow pine, 6" pattern 116 siding, 1" x 6". Select Grade except as noted. Each linear foot of 6" wide siding covers 0.38 square feet of wall. Do not deduct for wall openings less than 10 square feet. Add 5% for typical waste and end cutting.					
8' lengths	B1@.038	SF	4.64	1.30	5.94
10' lengths	B1@.037	SF	4.62	1.26	5.88
12' lengths	B1@.036	SF	4.68	1.23	5.91
Southern yellow pine, 6" pattern 117 siding, 1" x 6". Select Grade except as noted. Each linear foot of 6" wide siding covers 0.38 square feet of wall. Do not deduct for wall openings less than 10 square feet. Add 5% for typical waste and end cutting.					
8' lengths	B1@.038	SF	4.55	1.30	5.85
10' lengths	B1@.037	SF	4.67	1.26	5.93
12' lengths	B1@.036	SF	4.56	1.23	5.79
Southern yellow pine, 8" pattern 131 siding, 1" x 8". Select Grade except as noted. Each linear foot of 8" wide siding covers 0.54 square feet of wall. Do not deduct for wall openings less than 10 square feet. Add 5% for typical waste and end cutting.					
8' lengths	B1@.036	SF	4.14	1.23	5.37
10' lengths	B1@.034	SF	4.13	1.16	5.29
12' lengths	B1@.031	SF	4.12	1.06	5.18
Southern yellow pine, 8" pattern 122 siding, 1" x 8". "V"-joint. Select Grade except as noted. Each linear foot of 8" wide siding covers 0.54 square feet of wall. Do not deduct for wall openings less than 10 square feet. Add 5% for typical waste and end cutting.					
8' lengths	B1@.036	SF	4.09	1.23	5.32
10' lengths	B1@.034	SF	4.07	1.16	5.23
12' lengths	B1@.031	SF	4.05	1.06	5.11
Southern yellow pine, 6" pattern 122 siding, 1" x 6". Select Grade except as noted. Each linear foot of 6" wide siding covers 0.38 square feet of wall. Do not deduct for wall openings less than 10 square feet. Add 5% for typical waste and end cutting.					
8' lengths	B1@.038	SF	3.21	1.30	4.51
10' lengths	B1@.037	SF	3.20	1.26	4.46
12' lengths	B1@.036	SF	3.19	1.23	4.42
Southern yellow pine, 8" shiplap siding, 1" x 8". No. 2 Grade. Each linear foot of 8" wide siding covers 0.54 square feet of wall. Do not deduct for wall openings less than 10 square feet. Add 5% for typical waste and end cutting.					
8' lengths	B1@.036	SF	1.94	1.23	3.17
10' lengths	B1@.034	SF	1.75	1.16	2.91
12' lengths	B1@.031	SF	1.93	1.06	2.99
Rustic 8" pine siding, 1" x 8". "V"-grooved. Each linear foot of 8" wide siding covers 0.54 square feet of wall. Do not deduct for wall openings less than 10 square feet. Add 5% for typical waste and end cutting.					
16' lengths	B1@.031	SF	2.87	1.06	3.93
20' lengths	B1@.031	SF	2.92	1.06	3.98
Log cabin siding, 1-1/2" thick. Each linear foot of 6" wide siding covers 0.41 square feet of wall. Each linear foot of 8" wide siding covers .55 square feet of wall. Do not deduct for wall openings less than 10 square feet. Add 5% for typical waste and end cutting.					
6" x 8', T & G latia	B1@.038	SF	4.41	1.30	5.71
6" x 12', T & G latia	B1@.036	SF	4.49	1.23	5.72
8" x 12'	B1@.031	SF	4.86	1.06	5.92
8" x 16'	B1@.030	SF	4.85	1.02	5.87

Pressure-treated Lumber

Craft@Hrs Unit Material Labor Total

Log lap spruce siding, 1-1/2" thick. Each linear foot of 6" wide siding covers 0.41 square feet of wall. Each linear foot of 8" wide siding covers .55 square feet of wall. Each linear foot of 10" wide siding covers 0.72 square feet of wall. Do not deduct for wall openings less than 10 square feet. Add 5% for typical waste and end cutting.

6" width	B1@.038	SF	7.17	1.30	8.47
8" width	B1@.031	SF	7.08	1.06	8.14
10" width	B1@.030	SF	5.74	1.02	6.76

Timbers

	Unit	MBF	12' L	16' L	20' L
Green Douglas Fir timbers – #1 Grade					
4" x 8"	Ea	1,990.00	63.80	85.00	106.00
4" x 10"	Ea	1,840.00	73.60	98.10	123.00
4" x 12"	Ea	1,680.00	80.60	107.00	134.00
6" x 6"	Ea	2,220.00	80.10	107.00	133.00

	Unit	MBF	8' L	12' L	16' L
Green Douglas Fir timbers – #2 and Better					
4" x 4"	Ea	1,570.00	16.70	25.10	33.50
4" x 6"	Ea	1,530.00	24.50	36.70	48.90
4" x 8"	Ea	1,490.00	31.80	47.60	63.50
4" x 10"	Ea	1,660.00	44.30	66.40	88.60
4" x 12"	Ea	1,360.00	43.70	65.50	87.30

	Unit	MBF	12' L	16' L	20' L
Red Cedar timbers					
4" x 4" – Green S4S	Ea	6,010.00	96.10	128.00	160.00
4" x 4" – Rough	Ea	4,620.00	73.90	98.50	123.00
6" x 6" – Rough	Ea	7,080.00	255.00	340.00	425.00

	Unit	MBF	8' L	12' L	16' L
Redwood timbers West Coast prices. Add 10% to 30% for transportation to other areas.					
4" x 4" – Construction Common	Ea	2,310.00	24.60	36.90	49.20
4" x 4" – Construction Heart - Rough	Ea	2,860.00	30.50	45.80	61.00
4" x 4" – Construction Heart – S4S	Ea	3,330.00	35.50	53.20	70.90

Pressure-treated lumber, ACQ treatment

Pressure-treated trim board S4S, .25 ACQ treatment, Appearance Grade					
1" x 4" – .25 appearance grade	Ea	2,770.00	7.37	11.10	14.70
1" x 6" – .25 appearance grade	Ea	2,080.00	8.32	12.50	16.60
1" x 8" – .25 appearance grade	Ea	1,970.00	10.50	15.80	21.10

Pressure-treated trim board S4S, .25 treatment, D Grade					
1" x 4", – .25 D grade	Ea	2,580.00	6.87	10.30	13.70
1" x 6", – .25 D grade	Ea	2,590.00	10.30	15.50	20.70
1" x 8", – .25 D grade	Ea	2,430.00	12.90	19.40	25.90
1" x 12", – .25 D grade	Ea	3,230.00	25.90	38.80	51.80

Pressure-treated lumber, .25 ACQ treatment					
2" x 3"	Ea	1,200.00	6.41	9.61	12.80
2" x 4"	Ea	1,620.00	8.61	12.90	17.20
2" x 6"	Ea	1,320.00	10.50	15.80	21.10
2" x 8"	Ea	1,390.00	14.90	22.30	29.80
2" x 10"	Ea	1,860.00	24.80	37.30	49.70
2" x 12"	Ea	2,140.00	34.30	51.40	68.50
4" x 4"	Ea	1,940.00	20.70	31.10	41.50
4" x 6"	Ea	2,330.00	37.30	55.90	74.60
4" x 8"	Ea	2,130.00	45.50	68.30	91.00

Lumber, Plywood

	Unit	MBF	8' L	12' L	16' L
4" x 10"	Ea	2,190.00	58.30	87.40	117.00
4" x 12"	Ea	2,290.00	73.30	110.00	147.00
6" x 6"	Ea	2,180.00	52.40	78.50	105.00
Pressure-treated southern yellow pine – .40 ACQ treatment, Prime					
1" x 4"	Ea	1,530.00	4.07	6.11	8.14
1" x 6"	Ea	1,360.00	5.43	8.14	10.90
2" x 4"	Ea	1,150.00	6.15	9.22	12.30
2" x 6"	Ea	1,060.00	8.48	12.70	17.00
2" x 8"	Ea	1,100.00	11.80	17.60	23.50
2" x 10"	Ea	1,050.00	14.00	20.90	27.90
2" x 12"	Ea	1,590.00	25.40	38.10	50.80
Pressure-treated timbers .40 CCA pressure treatment. For uses with direct contact with water or the ground, or where moisture content exceeds 20%. Add 20% for .60 CCA treated southern yellow pine timber.					
4" x 4"	Ea	1,080.00	11.50	17.20	22.90
4" x 6"	Ea	1,140.00	18.20	27.30	36.30
6" x 6"	Ea	1,240.00	29.80	44.80	59.70

Identification Index:
A set of two numbers separated by a slash that appears in the grade trademarks on standard sheathing, Structural I, Structural II and C-C Grades. Number on left indicates recommended maximum spacing in inches for supports when panel is used for roof decking. Number on right shows maximum recommended spacing in inches for supports when the panel is used for subflooring.

	Unit	8' L	10' L	12' L	16' L
Hibor treated Douglas fir (Hawaii)					
2" x 4", Standard and Better	Ea	8.77	11.20	13.50	18.00
2" x 6", No. 2 and Better	Ea	13.80	17.30	21.20	28.60
2" x 8", No. 2 and Better	Ea	20.60	24.40	29.00	38.80
2" x 10", No. 2 and Better	Ea	28.60	35.00	42.20	56.20
2" x 12", No. 2 and Better	Ea	37.10	46.20	56.20	74.20
4" x 4", No. 2 and Better	Ea	21.80	30.70	37.70	—
4" x 6", No. 2 and Better	Ea	36.90	47.00	58.30	49.40
4" x 8", No. 1 and Better, S4S	Ea	—	—	79.50	105.00
4" x 10", No. 1 and Better, S4S	Ea	—	—	105.00	140.00
4" x 12", No. 1 and Better, S4S	Ea	—	—	115.00	154.00

Plywood

	Unit	MSF	4' x 8'
Sanded Exterior Grade Western plywood – AC			
1/4" thick	Ea	2,400.00	76.90
3/8" thick	Ea	2,870.00	92.00
1/2" thick	Ea	3,110.00	99.70
5/8" thick	Ea	3,100.00	99.40
3/4" thick	Ea	3,300.00	106.00
Exterior Grade plywood – CDX			
3/8" thick	Ea	884.00	28.30
1/2" thick	Ea	1,340.00	42.80
1/2" thick, 4-ply	Ea	1,550.00	49.60
1/2" thick, 5-ply	Ea	2,000.00	64.00
5/8" thick, 4-ply	Ea	1,510.00	48.30
5/8" thick, 5-ply	Ea	2,320.00	74.10
3/4" thick	Ea	1,530.00	48.90
Sanded Exterior Grade Western plywood – BC			
1/4" thick	Ea	987.00	31.60
3/8" thick	Ea	1,320.00	42.30
1/2" thick	Ea	1,670.00	53.40
5/8" thick	Ea	1,480.00	47.40
3/4" thick	Ea	1,680.00	53.90

A-A EXT-DFPA.
Designed for use in exposed applications where the appearance of both sides is important. Fences, wind screens, exterior cabinets and built-ins, signs, boats, commercial refrigerators, shipping containers, tanks, and ducts.
A-A G-2 EXT-DFPA PS 1-68
Typical edge-mark

A-B EXT-DFPA.
For uses similar to A-A EXT but where the appearance of one side is a little less important than the face.
A-B G-3 EXT-DFPA PS 1-68
Typical edge-mark

Lumber, Plywood

	Craft@Hrs	Unit	Material	Labor	Total
Texture 1-11 (T-1-11) siding, rough sawn. Per 100 square feet installed including 10% cutting waste.					
3/8" x 4' x 8' Southern pine, grooved 4" OC	B1@2.18	Sq	192.00	74.40	266.40
3/8" x 4' x 8' Decorative southern pine	B1@2.18	Sq	181.00	74.40	255.40
3/8" x 4' x 8' Hibor treated, plain (Hawaii)	B1@2.18	Sq	257.00	74.40	331.40
5/8" x 4' x 8' Premium pine, grooved	B1@2.45	Sq	256.00	83.60	339.60
5/8" x 4' x 8' Treated pine, Decorative Grade	B1@2.45	Sq	344.00	83.60	427.60
5/8" x 4' x 9' Fir, grooved	B1@2.45	Sq	447.00	83.60	530.60
5/8" x 4' x 8' Hibor treated, grooved (Hawaii)	B1@2.45	Sq	344.00	83.60	427.60
5/8" x 4' x 9' Hibor treated, grooved (Hawaii)	B1@2.45	Sq	404.00	83.60	487.60
		Unit		MSF	4' x 8'
2-4-1 Sturdi-Floor subflooring. Tongue and groove attic decking					
5/8"		Ea	1,960.00		34.50
Concrete form (Plyform), square edged					
5/8", 4 ply		Ea	2,260.00		72.20
3/4", 4 ply		Ea	2,390.00		76.40
Structural I Grade plywood. Price per panel					
3/8"		Ea	1,220.00		38.90
1/2"		Ea	1,420.00		45.30
Medium-Density Overlay (MDO) plywood. Paintable paper surface bonded to plywood core.					
3/8"		Ea	3,770.00		121.00
1/2"		Ea	2,810.00		89.80
3/4"		Ea	3,220.00		103.00
Marine-Grade plywood					
1/2", AB Grade		Ea	3,220.00		103.00
3/4", AB Grade		Ea	3,550.00		114.00
OSB strand board – square edged, oriented grain					
1/4"		Ea	793.00		25.40
3/8"		Ea	1,430.00		45.60
7/16"		Ea	1,060.00		33.80
1/2"		Ea	1,410.00		45.20
3/4"		Ea	1,900.00		60.80
Underlayment "X"-Band, C Grade, tongue and groove					
5/8", 4 ply		Ea	2,100.00		67.30
3/4", 4 ply		Ea	2,280.00		73.00
Birch hardwood plywood					
1/8" thick		Ea	1,610.00		51.50
1/4" thick		Ea	1,070.00		34.40
1/2" thick		Ea	2,180.00		69.80
3/4" thick		Ea	2,160.00		69.30
Cedar hardwood plywood					
1/4" thick		Ea	3,260.00		104.00
3/8" thick		Ea	3,950.00		126.00
1/2" thick		Ea	5,500.00		176.00
5/8" thick		Ea	6,340.00		203.00
3/4" thick		Ea	7,370.00		236.00
Oak hardwood plywood					
1/8" thick		Ea	1,200.00		38.40
1/4" thick		Ea	1,380.00		44.20
1/2" thick		Ea	2,500.00		79.90
3/4" thick		Ea	2,240.00		71.60
Lauan plywood					
1/8" thick		Ea	599.00		19.20
1/4" thick		Ea	709.00		22.70
1/4" thick, moisture resistant		Ea	829.00		26.50

Lumber, Recycled Plastic

	Craft@Hrs	Unit	Material	Labor	Total
Hardboard, 4' x 8' panels					
1/8" tempered hardboard	BC@1.02	Ea	12.10	38.40	50.50
1/8" tempered pegboard	BC@1.02	Ea	19.70	38.40	58.10
1/8" backer board	BC@1.02	Ea	22.10	38.40	60.50
1/4" tempered hardboard	BC@1.02	Ea	19.00	38.40	57.40
3/16" white garage liner pegboard	BC@1.02	Ea	23.30	38.40	61.70
1/4" white vinyl coated	BC@1.02	Ea	33.90	38.40	72.30
1/4" tempered perforated pegboard	BC@1.02	Ea	20.60	38.40	59.00
Particleboard					
3/8" x 4' x 8'	—	Ea	18.10	—	18.10
1/2" x 4' x 8'	—	Ea	22.90	—	22.90
5/8" x 4' x 8'	—	Ea	27.10	—	27.10
3/4" x 4' x 8'	—	Ea	27.00	—	27.00
3/4" x 25" x 97" countertop	—	Ea	21.70	—	21.70
3/4" x 30" x 97", countertop	—	Ea	27.40	—	27.40
3/4" x 25" x 121", countertop	—	Ea	32.90	—	32.90
3/4" x 25" x 145", countertop	—	Ea	34.10	—	34.10
3/4" x 49" x 97", industrial grade	—	Ea	35.10	—	35.10

	Unit	MBF	8' L	12' L	16' L
Recycled Plastic Lumber Produced from post-consumer plastics. Resistant to termites, rot, decay.					
2" x 4"	Ea	8,160.00	43.40	65.10	87.10
2" x 6"	Ea	8,300.00	66.10	99.70	132.00
2" x 8"	Ea	8,510.00	90.90	136.00	181.00
2" x 10"	Ea	7,710.00	103.00	155.00	205.00
2" x 12"	Ea	8,280.00	132.00	199.00	265.00
4" x 4"	Ea	8,590.00	91.60	138.00	184.00
4" x 6"	Ea	9,130.00	145.00	219.00	292.00
6" x 6"	Ea	7,970.00	192.00	286.00	382.00
1" x 6" siding, smooth edge	Ea	8,570.00	34.20	51.50	68.60
1" x 6" siding, tongue & groove	Ea	6,380.00	25.50	38.30	51.00

Poles Select Appearance Grade building poles. Poles have an average taper of 1" in diameter per 10' of length. Ponderosa pine treated with Penta-Dow or ACZA (.60 lbs/CF), meets AWPA-C 23-77. Costs based on quantity of 8 to 10 poles. For delivery of smaller quantities, add \$50.00 to the total cost. See installation labor below. Costs are per linear foot.

	Unit	8" butt size	10" butt size	12" butt size
To 15' long pole	LF	13.30	17.30	22.60
To 20' long pole	LF	12.90	16.10	21.10
To 25' long pole	LF	12.40	13.60	19.30
Add for Douglas fir	LF	2.99	3.11	3.25
Add for delivery, typical per trip	Ea	90.00	90.00	90.00

	Unit	6' long	7' long	8' long	10' long
Posts Sawn posts, construction common, redwood					
4" x 4"	Ea	15.80	18.50	20.40	26.20
Yellow pine penta treated posts					
3" x 3"	Ea	8.11	9.81	11.40	13.40
3-1/2" x 3-1/2"	Ea	9.12	10.70	12.20	13.90
4" x 4"	Ea	11.30	13.40	14.30	16.10
4-1/2" x 4-1/2"	Ea	13.70	14.40	14.80	16.60
5" x 5"	Ea	13.40	16.10	17.10	20.20
6" x 6"	Ea	16.10	18.30	19.20	21.40

Lumber, Stakes

	Unit	8' long	10' long	12' long	16' long
Pressure-treated southern yellow pine posts No. 2, 0.40 CCA treatment					
4" x 4"	Ea	26.10	32.30	39.00	51.80
4" x 6"	Ea	36.10	45.00	54.10	72.20
6" x 6"	Ea	61.70	76.90	92.30	124.00

	Craft@Hrs	Unit	Material	Labor	Total
--	-----------	------	----------	-------	-------

Labor to install poles and posts Costs shown are per post and include measuring, cutting one end, drilling two holes at the top and bottom and installation. Add for hardware and bolts as needed.

3" x 3", 4" x 4" or 5" x 5" posts	B1@.333	Ea	—	11.40	11.40
6" x 6" or 7" x 7" posts	B1@.500	Ea	—	17.10	17.10
8" or 10" butt diameter poles	B1@.666	Ea	—	22.70	22.70
12" butt diameter poles	B1@.750	Ea	—	25.60	25.60

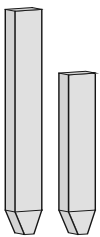

Stakes

Survey stakes, pine or fir, 1" x 2"

18"	—	Ea	.30	—	.30
24"	—	Ea	.35	—	.35
36"	—	Ea	.73	—	.73

Ginnies, pine or fir, 1" x 1", per 1,000

6"	—	M	114.00	—	114.00
8"	—	M	111.00	—	111.00

Pointed lath, pine or fir, per 1,000, 1/4" x 1-1/2", S4S

18"	—	M	312.00	—	312.00
24"	—	M	338.00	—	338.00
36"	—	M	466.00	—	466.00
48"	—	M	637.00	—	637.00

Foundation stakes, 1" x 3", per 1,000, 20 bundles per 1000 except for 48" (40 bundles per 1000)

12" or 14"	—	M	384.00	—	384.00
18"	—	M	493.00	—	493.00
24"	—	M	569.00	—	569.00
36"	—	M	804.00	—	804.00
48"	—	M	1,310.00	—	1,310.00

Hubs, pine or fir, 2" x 2", per 1,000

8"	—	M	673.00	—	673.00
10"	—	M	750.00	—	750.00
12"	—	M	819.00	—	819.00

Form stakes (wedges), pine or fir, 5" point, per 1,000

2" x 2" x 6"	—	M	262.00	—	262.00
2" x 2" x 8"	—	M	283.00	—	283.00
2" x 2" x 10"	—	M	310.00	—	310.00
2" x 4" x 6"	—	M	342.00	—	342.00
2" x 4" x 8"	—	M	402.00	—	402.00
2" x 4" x 10"	—	M	434.00	—	434.00
2" x 4" x 12"	—	M	493.00	—	493.00
Feather wedges	—	M	368.00	—	368.00

Lumber Grading Lumber grading services by West Coast Lumber Inspection Bureau.

Inspection per MBF	—	MBF	—	—	.42
Per month minimum – operating and shipping	—	Month	—	—	416.00
Per month min. – non-operating (No Shipments)	—	Month	—	—	130.00

Lumber Preservation Treatment

	Craft@Hrs	Unit	Material	Labor	Total
Reinspection, certificate inspection and grade stamping service for WCLIB Members. Costs do not include travel and subsistence charges.					
On shipments west of the Rocky Mountains	—	Day	—	—	531.00
Overtime hours	—	Hour	—	—	100.00
Saturday, Sunday and holidays	—	Day	—	—	848.00
On shipments east of the Rocky Mountains	—	Day	—	—	541.00
Overtime hours	—	Hour	—	—	98.90
Saturday, Sunday and holidays	—	Day	—	—	848.00
Reinspection, certificate inspection and grade stamping service for WCLIB Non-Members. Costs do not include travel and subsistence charges.					
On shipments west of the Rocky Mountains	—	Day	—	—	734.00
Overtime hours	—	Hour	—	—	132.00
Saturday, Sunday and holidays	—	Day	—	—	1,050.00
On shipments east of the Rocky Mountains	—	Day	—	—	729.00
Overtime hours	—	Hour	—	—	132.00
Saturday, Sunday and holidays	—	Day	—	—	1,050.00
Certificate inspection service. Issuance of certificates to inspection subscribers employing WCLIB certified inspectors.					
Per thousand board feet, \$30.00 minimum	—	MBF	—	—	0.36
Lumber Preservation Treatment See also Soil Treatments. Costs assume treatment at a treatment plant, not on the construction site. Treatments listed below are designed to protect wood and wood products from decay and destruction caused by moisture (fungi), wood-boring insects and organisms. All retention rates listed (in parentheses) are in pounds per cubic foot and are the minimum recommended by the Society of American Wood Preservers. Costs are for treatment only and assume treating of 10,000 board feet or more. No lumber or transportation included. Add \$70.00 per MBF for kiln-drying after treatment.					
Lumber submerged in or frequently exposed to salt water					
ACZA treatment (2.5)	—	MBF	—	—	1,030.00
ACZA treatment for structural lumber					
Piles and building poles (2.5)	—	CF	—	—	11.60
Board lumber and timbers (2.5)	—	MBF	—	—	1,030.00
Creosote treatment for structural lumber					
Piles and building poles (20.0)	—	CF	—	—	10.30
Board lumber and timbers (25.0)	—	MBF	—	—	614.00
Lumber in contact with fresh water or soil, ACZA treatment					
Building poles, structural (.60)	—	CF	—	—	6.47
Boards, timbers, structural (.60)	—	MBF	—	—	299.00
Boards, timbers, non-structural (.40)	—	MBF	—	—	261.00
Plywood, structural (.40), 1/2"	—	MSF	—	—	297.00
Posts, guardrail, signs (.60)	—	MBF	—	—	371.00
All weather foundation KD lumber (.60)	—	MBF	—	—	411.00
All weather foundation, 1/2" plywood (.60)	—	MSF	—	—	331.00
Lumber in contact with fresh water or soil, creosote treatment					
Piles, building poles, structural (12.0)	—	CF	—	—	7.33
Boards, timbers, structural (12.0)	—	MBF	—	—	446.00
Boards, timbers, non-structural (10.0)	—	MBF	—	—	411.00
Plywood, structural, 1/2" (10.0)	—	MSF	—	—	354.00
Posts (fence, guardrail, sign) (12.0)	—	MBF	—	—	446.00
Lumber used above ground, ACZA treatment					
Boards, timbers, structural (.25)	—	MBF	—	—	244.00
Boards, timbers, non-structural (.25)	—	MBF	—	—	240.00
Plywood, structural 1/2" (.25)	—	MSF	—	—	274.00

Mailboxes

	Craft@Hrs	Unit	Material	Labor	Total
Lumber used above ground, creosote treatment					
Boards, timbers, structural (8.0)	—	MBF	—	—	371.00
Boards, timbers, non-structural (8.0)	—	MBF	—	—	371.00
Plywood, structural (8.0), 1/2"	—	MSF	—	—	330.00
Lumber used for decking, ACQ treatment					
Boards, structural (.41)	—	MBF	—	—	319.00
Boards, timbers, non-structural (.41)	—	MSF	—	—	319.00
Fire retardant treatments, structural use (interior only), "D-Blaze"					
Surfaced lumber	—	MBF	—	—	342.00
Rough lumber	—	MBF	—	—	342.00
Architectural use (interior and exterior), "NCX"					
Surfaced lumber	—	MBF	—	—	788.00
Rough lumber	—	MBF	—	—	788.00
Wolmanized treatment. Copper chromated arsenic preservative is not used for residential applications. The term "Wolmanized" is now being applied to ACQ and CA preservatives which do not contain arsenic.					
Lumber used above ground (.25)	—	MBF	—	—	126.00
Lumber in ground contact or fresh water (.40)	—	MBF	—	—	154.00
Lumber used as foundation (.60)	—	MBF	—	—	165.00

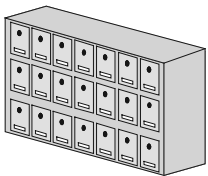

Mailboxes

Apartment type, vertical, meets current postal regulations, tumbler locks, aluminum or gold finish, price per unit, recessed

3 box unit, 5-1/2" wide x 16" high	B1@1.88	Ea	199.00	64.10	263.10
4 box unit, 5-1/2" wide x 16" high	B1@1.88	Ea	255.00	64.10	319.10
5 box unit, 5-1/2" wide x 16" high	B1@1.88	Ea	342.00	64.10	406.10
6 box unit, 5-1/2" wide x 16" high	B1@1.88	Ea	367.00	64.10	431.10
7 box unit, 5-1/2" wide x 16" high	B1@1.88	Ea	423.00	64.10	487.10
Add for surface mounting collar	B1@.550	Ea	51.00	18.80	69.80

Office type, horizontal, meets postal regulations, tumbler locks, aluminum or brass finish

For front or rear load, per box

23" wide x 30" high x 12" deep	B1@1.02	Ea	840.00	34.80	874.80
--------------------------------	---------	----	--------	-------	--------

Rural, aluminum finish, 19" long x 6-1/2" wide x 9" high, with flag

Black, does not include mounting post	B1@.776	Ea	19.30	26.50	45.80
---------------------------------------	---------	----	-------	-------	-------

Rural heavy gauge steel mailboxes, aluminum finish, 19" long x 7" wide x 10" high, with flag

Vandal-proof, does not include mounting post	B1@.776	Ea	89.30	26.50	115.80
--	---------	----	-------	-------	--------

Suburban style, finished, 16" long x 3" wide x 6" deep, with flag

Post mount bracket, does not include post	B1@.776	Ea	30.30	26.50	56.80
---	---------	----	-------	-------	-------

Add for 5' high aluminum post	—	Ea	69.50	—	69.50
-------------------------------	---	----	-------	---	-------

Cast aluminum mailbox and pedestal, 18" x 12" box, 4' pedestal,

With base, lockable	B1@.776	Ea	188.00	26.50	214.50
---------------------	---------	----	--------	-------	--------

Bronze mailbox and post, 18" x 12" box, 5' post,

Steel anchor base	B1@.776	Ea	466.00	26.50	492.50
-------------------	---------	----	--------	-------	--------

Plastic mailbox, mounting sleeve slides over 4' high post, lockable

Size 1 box, add for post	B1@.776	Ea	63.60	26.50	90.10
--------------------------	---------	----	-------	-------	-------

Add for treated wood or aluminum post	—	Ea	32.40	—	32.40
---------------------------------------	---	----	-------	---	-------

Thru-the-wall type, 13" long x 3" high

Gold or aluminum finish	B1@1.25	Ea	35.40	42.60	78.00
-------------------------	---------	----	-------	-------	-------

Wall- or post-mount security mailboxes, lockable, 15" wide x 13" high x 8" deep

Black plastic and aluminum	B1@.450	Ea	73.40	15.30	88.70
----------------------------	---------	----	-------	-------	-------

Mantels, Ponderosa Pine Unfinished.

Modern design, 50" x 37" opening,

paint grade, 11" x 77" shelf	B1@3.81	Ea	1,620.00	130.00	1,750.00
------------------------------	---------	----	----------	--------	----------

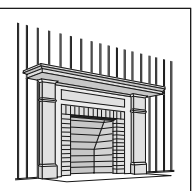

Markup

	Craft@Hrs	Unit	Material	Labor	Total
Colonial design, 50" x 39" opening, stain grade, 7" x 72" shelf	B1@3.81	Ea	2,590.00	130.00	2,720.00
Ornate design, 51-1/2" x 39" opening, with detailing and scroll work, stain grade 11" x 68" shelf	B1@3.81	Ea	4,800.00	130.00	4,930.00
Mantel molding (simple trim for masonry fireplace openings) 15 LF, for opening 6'0" x 3'6" or less	B1@1.07	Set	572.00	36.50	608.50
Mantel shelf only, with iron or wood support brackets, prefinished					
4" x 8" x 8"	B1@.541	Ea	115.00	18.50	133.50
4" x 8" x 6"	B1@.541	Ea	113.00	18.50	131.50
4" x 10" x 10"	B1@.541	Ea	253.00	18.50	271.50

Marble Setting, Subcontract See also Tile section. Marble prices vary with quality, quantity, and availability of materials. Check prices with local suppliers. These prices are based on 200 SF quantities.

Marble tile flooring, tiles or slabs

3/8" x 12" x 12", thin set over concrete slab. Typical cost per SF of area covered	—	SF	—	—	24.50
3/4" slabs set in mortar bed, cut to size. Typical cost per SF of area covered	—	SF	—	—	82.70

Marble bathroom vanity top, to 96" x 24" wide, with one sink cutout, bullnose or eased edge on 3 sides.

Most colors and textures	—	Ea	—	—	1,260.00
Select colors and textures	—	Ea	—	—	1,550.00

Marble fireplace mantel and facing. 46" high to 67" wide overall. Including typical delivery. Custom-made mantels require several months for production and delivery.

Minimum, plain design, white marble	—	Ea	—	—	1,340.00
Better quality, limestone	—	Ea	—	—	2,430.00
Ornet design, onyx	—	Ea	—	—	3,850.00

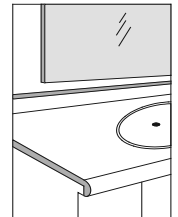

Markup Typical markup for light construction, percentage of gross contract price. No insurance or taxes included. See also Insurance and Taxes sections. Markup is the amount added to an estimate after all job costs have been accounted for: labor and materials, job fees, permits, bonds and insurance, job site supervision and similar job-related expenses. Profit is the return on money invested in the construction business.

Contingency (allowance for unknown and unforeseen conditions) Varies widely from job to job, typically	—	%	—	—	2.0
Overhead (office, administrative and general business expense) Typical overhead expense	—	%	—	—	10.0
Profit (return on the money invested in the business, varies with competitive conditions) Typical profit for residential construction	—	%	—	—	8.0
Total markup (add 25% to the total job cost to attain 20% of gross contract price) Total for Contingency, Overhead & Profit	—	%	—	—	20.0

Note that costs listed in this book do not include the general contractor's markup. However, sections identified as "subcontract" include the subcontractor's markup. Here's how to calculate markup:

Project Costs

Material	\$ 50,000
Labor (with taxes & insurance)	40,000
Subcontract	10,000
Total job costs	100,000
Markup (25% of \$100,000)	\$ 25,000
Contract price	\$125,000
Markup is \$25,000 which is 25% of the total job costs (\$100,000) but only 20% of the contract price (\$25,000 divided by \$125,000 is .20).	

Markup For General Contractors On larger commercial and industrial projects, a markup of 24.8% on the total job cost is suggested. See the paragraph General Contractor Markup at the beginning of the section General Requirements in the Industrial and Commercial Division of this manual. For example, note how markup is calculated on a project with these costs:

Material	\$ 3,000,000
Labor (with taxes and insurance)	4,500,000
Equipment	1,000,000
Subcontracts	<u>1,500,000</u>
Total job cost	\$10,000,000
Indirect overhead (8%)	800,000
Direct overhead (7.3%)	730,000
Contingency (2%)	200,000
Profit (7.5%)	<u>750,000</u>
Contract price	\$12,480,000

Note that the total job cost includes both work done with the general contractor's crews and work done by subcontractor-specialists. Markup for the general contractor (overhead, including supervision expense, contingency and profit) is \$2,480,000. This is 24.8% of the total job costs but only 19.87% of the contract price (\$2,480,000 divided by \$12,480,000 is 0.1987).

Craft@Hrs Unit Material Labor Total

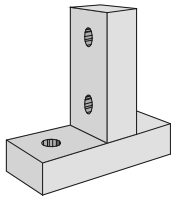

Masonry, Brick Wall Assemblies Typical costs for smooth red clay brick walls, laid in running bond with 3/8" concave joints. These costs include the bricks, mortar for bricks and cavities, typical ladder type reinforcing, wall ties and normal waste. Foundations are not included. Wall thickness shown is the nominal size based on using the type bricks described. "Wythe" means the quantity of bricks in the thickness of the wall. Costs shown are per square foot (SF) of wall measured on one face. Deduct for openings over 10 SF in size. The names and dimensions of bricks can be expected to vary, depending on the manufacturer. For more detailed coverage of brick and masonry see the *National Concrete & Masonry Estimator* at <https://craftsman-book.com/national-estimator-cloud>.

Standard brick, 3-3/4" wide x 2-1/4" high x 8" long

Common brick, per thousand	—	M	800.00	—	800.00
4" thick wall, single wythe, veneer facing	B9@.211	SF	6.52	7.04	13.56
8" thick wall, double wythe, cavity filled	B9@.464	SF	12.90	15.50	28.40
12" thick wall, triple wythe, cavity filled	B9@.696	SF	19.20	23.20	42.40

Norman brick, 3-1/2" wide x 2-1/2" high x 11-1/2" long

Norman brick, per thousand	—	M	1,360.00	—	1,360.00
4" thick wall, single wythe, veneer facing	B9@.211	SF	7.12	7.04	14.16
8" thick wall, double wythe, cavity filled	B9@.464	SF	14.10	15.50	29.60
12" thick wall, triple wythe, cavity filled	B9@.696	SF	21.00	23.20	44.20

Modular brick, 3" wide x 3-1/2" x 11-1/2" long

Modular brick, per thousand	—	M	1,360.00	—	1,360.00
3-1/2" thick wall, single wythe, veneer face	B9@.156	SF	5.12	5.20	10.32
7-1/2" thick wall, double wythe, cavity filled	B9@.343	SF	10.10	11.40	21.50
11-1/2" thick wall, triple wythe, cavity filled	B9@.515	SF	15.10	17.20	32.30

Colonial brick, 3" wide x 3-1/2" x 10" long

Colonial brick, per thousand	—	M	995.00	—	995.00
3-1/2" thick wall, single wythe, veneer face	B9@.177	SF	4.53	5.90	10.43
7-1/2" thick wall, double wythe, cavity filled	B9@.389	SF	8.87	13.00	21.87
11-1/2" thick wall, triple wythe, cavity filled	B9@.584	SF	13.20	19.50	32.70

Masonry, Face Brick

Craft@Hrs Unit Material Labor Total

Masonry, Face Brick Laid in running bond with 3/8" concave joints. Mortar, wall ties and foundations (footings) not included. Includes normal waste and delivery up to 30 miles with a 5 ton minimum. Coverage (units per SF) includes 3/8" mortar joints but the SF cost does not include mortar cost. Add for mortar below.



Standard brick, 2-1/4" high x 3-3/4" deep x 8" long (6.45 units per SF)					
Brown, per square foot	B9@.211	SF	5.83	7.04	12.87
Brown, per thousand	B9@32.7	M	861.00	1,090.00	1,951.00
Burnt oak, per square foot	B9@.211	SF	6.50	7.04	13.54
Burnt oak, per thousand	B9@32.7	M	960.00	1,090.00	2,050.00
Flashed, per square foot	B9@.211	SF	7.64	7.04	14.68
Flashed, per thousand	B9@32.7	M	1,130.00	1,090.00	2,220.00
Red, per square foot	B9@.211	SF	5.41	7.04	12.45
Red, per thousand	B9@32.7	M	799.00	1,090.00	1,889.00
Norman brick, 2-1/2" high x 3-1/2" deep x 11-1/2" long (4.22 units per SF)					
Brown	B9@.211	SF	7.64	7.04	14.68
Burnt oak	B9@.211	SF	8.52	7.04	15.56
Flashed	B9@.211	SF	6.05	7.04	13.09
Red	B9@.211	SF	6.05	7.04	13.09
Modular, 3-1/2" high x 3" deep x 11-1/2" long (3.13 units per SF)					
Brown	B9@.156	SF	5.62	5.20	10.82
Burnt oak	B9@.156	SF	5.75	5.20	10.95
Flashed	B9@.156	SF	4.48	5.20	9.68
Red	B9@.156	SF	4.25	5.20	9.45
Jumbo (filler brick) 3-1/2" high x 3" deep x 11-1/2" long (3.13 units per SF)					
Fireplace, cored	B9@.156	SF	1.82	5.20	7.02
Fireplace, solid	B9@.156	SF	1.61	5.20	6.81
Mission, cored	B9@.156	SF	3.49	5.20	8.69
Mission, solid	B9@.156	SF	3.58	5.20	8.78
Padre brick, 4" high x 3" deep					
7-1/2" long cored, 4.2 per SF	B9@.156	SF	8.47	5.20	13.67
7-1/2" long solid, 4.2 per SF	B9@.156	SF	10.70	5.20	15.90
11-1/2" long cored, 2.8 per SF	B9@.177	SF	6.57	5.90	12.47
11-1/2" long solid, 2.8 per SF	B9@.177	SF	9.60	5.90	15.50
15-1/2" long cored, 2.1 per SF	B9@.211	SF	7.78	7.04	14.82
15-1/2" long solid, 2.1 per SF	B9@.211	SF	9.77	7.04	16.81
Commercial, 3-1/4" high x 3-1/4" deep x 10" long (3.6 per SF)					
Solid	B9@.156	SF	3.76	5.20	8.96
Cored	B9@.177	SF	3.76	5.90	9.66
Harlequin (manufactured "used" brick)	B9@.177	SF	3.99	5.90	9.89
Add for 6-11/16" 22 gauge galvanized wall ties					
50 ties per 100 SF	B9@.011	SF	.10	.37	.47
Add for header course every 6th course	B9@.009	SF	.89	.30	1.19
Add for Flemish bond					
With header course every 6th course	B9@.036	SF	.49	1.20	1.69
Add for raked joints, labor	—	%	—	3.0	—
Deduct for flush finished joints, labor	—	%	—	-4.0	—

Mortar for brick Based on an all-purpose Type S mortar mix used in single wythe walls laid with running bond. Includes normal waste. Type N mortar is used for severe conditions, such as chimneys. Costs are per CSF of wall face using the brick sizes (width x height x length) listed. Material costs published based upon purchasing mortar by 1/2 cubic foot bag. If purchasing by the CY, reduce material costs 36%. Mortar purchased by the CY and pumped in place will reduce mortar material costs by about 16%.

Type S mortar, per cubic foot	—	CF	11.60	—	11.60
Type S mortar, 60 lb. bag	—	Ea	5.77	—	5.77
Type S mortar, per cubic yard	—	%	-36.0	—	—
Type S mortar, per cubic yard, pumped	—	%	-16.0	—	—

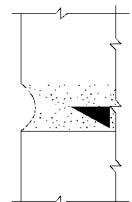

Masonry, Mortar

	Craft@Hrs	Unit	Material	Labor	Total
4" x 2-1/2" to 2-5/8" x 8" bricks					
3/8" joints (5.5 CF per CSF)	—	CSF	63.60	—	63.60
1/2" joints (7.0 CF per CSF)	—	CSF	80.90	—	80.90
4" x 3-1/2" to 3-5/8" x 8" bricks					
3/8" joints (4.8 CF per CSF)	—	CSF	55.50	—	55.50
1/2" joints (6.1 CF per CSF)	—	CSF	70.50	—	70.50
4" x 4" x 8" bricks					
3/8" joints (4.2 CF per CSF)	—	CSF	48.50	—	48.50
1/2" joints (5.3 CF per CSF)	—	CSF	61.20	—	61.20
4" x 5-1/2" to 5-5/8" x 8" bricks					
3/8" joints (3.5 CF per CSF)	—	CSF	40.40	—	40.40
1/2" joints (4.4 CF per CSF)	—	CSF	50.80	—	50.80
4" x 2" x 12" bricks					
3/8" joints (6.5 CF)	—	CSF	75.10	—	75.10
1/2" joints (8.2 CF per CSF)	—	CSF	94.80	—	94.80
4" x 2-1/2" to 2-5/8" x 12" bricks					
3/8" joints (5.1 CF per CSF)	—	CSF	58.90	—	58.90
1/2" joints (6.5 CF per CSF)	—	CSF	75.10	—	75.10
4" x 3-1/2" to 3-5/8" x 12" bricks					
3/8" joints (4.4 CF per CSF)	—	CSF	50.80	—	50.80
1/2" joints (5.6 CF per CSF)	—	CSF	64.70	—	64.70
4" x 4" x 12" bricks					
3/8" joints (3.7 CF per CSF)	—	CSF	42.80	—	42.80
1/2" joints (4.8 CF per CSF)	—	CSF	55.50	—	55.50
4" x 5-1/2" to 5-5/8" x 12" bricks					
3/8" joints (3.0 CF per CSF)	—	CSF	34.70	—	34.70
1/2" joints (3.9 CF per CSF)	—	CSF	45.10	—	45.10
6" x 2-1/2" to 2-5/8" x 12" bricks					
3/8" joints (7.9 CF per CSF)	—	CSF	91.30	—	91.30
1/2" joints (10.2 CF per CSF)	—	CSF	118.00	—	118.00
6" x 3-1/2" to 3-5/8" x 12" bricks					
3/8" joints (6.8 CF per CSF)	—	CSF	78.60	—	78.60
1/2" joints (8.8 CF per CSF)	—	CSF	102.00	—	102.00
6" x 4" x 12" bricks					
3/8" joints (5.6 CF per CSF)	—	CSF	64.70	—	64.70
1/2" joints (7.4 CF per CSF)	—	CSF	85.50	—	85.50

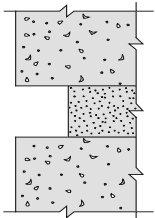
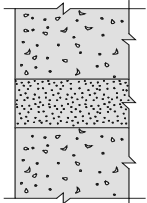

Mini-brick veneer strips Wirecut texture. Figures in parentheses indicate coverage using 1/2" grouted joints. No waste included.

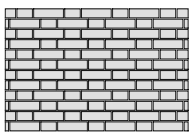

2-1/4" x 3/4" x 7-5/8" (6.7 units per SF)					
Unglazed, standard colors	B9@.300	SF	3.67	10.00	13.67
Unglazed, flashed	B9@.300	SF	4.68	10.00	14.68
Manufactured used	B9@.300	SF	3.88	10.00	13.88
3-5/8" x 1/2" x 7-5/8" (4.50 units per SF)					
Unglazed, standard colors	B9@.250	SF	3.60	8.34	11.94
Unglazed, flashed	B9@.250	SF	4.58	8.34	12.92
Manufactured used	B9@.250	SF	3.94	8.34	12.28
Mini-brick veneer strip corners					
Unglazed, standard colors	B9@.077	Ea	1.87	2.57	4.44
Unglazed, flashed	B9@.077	Ea	2.11	2.57	4.68
Manufactured used	B9@.077	Ea	2.03	2.55	4.52

Masonry, Brick Paver

	Craft@Hrs	Unit	Material	Labor	Total
Firebrick Used in chimneys and boilers, delivered to 30 miles, typical costs.					
Standard backs, 9" x 4-1/2" x 2-9/16"	B9@30.9	M	1,290.00	1,030.00	2,320.00
Split backs, 9" x 4-1/2" x 1-1/4"	B9@23.3	M	1,240.00	777.00	2,017.00
Fireclay, Dosch clay 50 lb. sack	—	Ea	11.90	—	11.90
Brick pavers Costs assume simple pattern with 1/2" mortar joints. Delivered to 30 miles, 10 ton minimum. Costs in material column include 8% for waste and breakage.					
Adobe pavers (Fresno)					
6" x 12" (2 units per SF)	B9@.193	SF	2.15	6.44	8.59
12" x 12" (1 unit per SF)	B9@.135	SF	2.15	4.50	6.65
California paver, 1-1/4" thick, brown					
3-5/8" x 7-5/8" (4.3 units per SF)	B9@.340	SF	4.62	11.30	15.92
Giant mission paver, 3" thick x 4" x 11-1/2"					
Red (2.67 units per SF)	B9@.193	SF	6.78	6.44	13.22
Redskin (2.67 units per SF)	B9@.193	SF	7.68	6.44	14.12
Mini-brick paver, 1/2" thick x 3-5/8" x 7-5/8"					
Sunset Red (4.5 units per SF)					
	B9@.340	SF	3.89	11.30	15.19
Red, flashed (4.5 units per SF)					
	B9@.340	SF	4.94	11.30	16.24
Manufactured (4.5 units per SF)					
	B9@.340	SF	4.26	11.30	15.56
Sunset Red, Dieskin texture (4.5 units per SF)					
	B9@.340	SF	3.05	11.30	14.35
Red, flashed, Dieskin texture (4.5 units per SF)					
	B9@.340	SF	3.79	11.30	15.09
Manufactured, Dieskin texture (4.5 units per SF)					
	B9@.340	SF	4.10	11.30	15.40
Re-roll texture, all colors (4.5 units per SF)					
	B9@.340	SF	3.68	11.30	14.98
Norman paver, 2-3/16" thick x 3-1/2" x 11-1/2" (3 units per SF)					
Sunset Red	B9@.222	SF	4.36	7.41	11.77
Red Flashed	B9@.222	SF	4.60	7.41	12.01
Split paver, 1-1/8" thick x 3-7/8" x 8-1/8" (4.5 units per SF)					
Red	B9@.209	SF	2.62	6.97	9.59
Manufactured, used	B9@.209	SF	3.15	6.97	10.12
Bullnose pavers, 2-3/16" thick x 3-1/2" x 11-1/2" (3 units per LF). Common applications include perimeter of brick patio, walkway and wall caps					
Single bullnose, Sunset Red	B9@.250	LF	7.69	8.34	16.03
Single bullnose, Brown Flashed	B9@.250	LF	9.09	8.34	17.43
Single bullnose, Iron Spot	B9@.250	LF	9.09	8.34	17.43
Double bullnose, Sunset Red	B9@.250	LF	11.50	8.34	19.84
Double bullnose, Brown Flashed	B9@.250	LF	12.20	8.34	20.54
Double bullnose, Iron Spot	B9@.250	LF	12.70	8.34	21.04
Bullnose corners, all colors	B9@.242	Ea	10.80	8.07	18.87
Mortar joints for pavers, 1/2" typical	B9@.010	SF	.23	.33	.56



Masonry, Block

Craft@Hrs Unit Material Labor Total

Concrete block wall assemblies Typical costs for standard natural gray medium weight masonry block walls including blocks, mortar, typical reinforcing and normal waste. Foundations (footings) are not included. See also individual component material and labor costs for blocks, mortar and reinforcing on the pages that follow. For more detailed coverage of concrete block see the *National Concrete and Masonry Estimator* at <https://craftsman-book.com/national-estimator-cloud>.

Walls constructed with 8" x 16" blocks laid in running bond

4" thick wall	B9@.090	SF	3.18	3.00	6.18
6" thick wall	B9@.100	SF	3.93	3.34	7.27
8" thick wall	B9@.120	SF	4.70	4.00	8.70
12" thick wall	B9@.150	SF	6.67	5.00	11.67

Grouting concrete block wall cores Typical costs for filling concrete block wall cores by hand. For pumped concrete, subtract 7% from labor cost and add 14% to material cost. 10% waste included in cost.

Using 2,000 psi (6.0 sack mix), per cubic yard — CY 148.00 — 148.00

Add for grouting cores poured by hand, all cores filled

4" thick wall, (4.98 SF per CF)	B9@.022	SF	1.13	.73	1.86
6" thick wall, (4.56 SF per CF)	B9@.023	SF	1.23	.77	2.00
8" thick wall, (3.79 SF per CF)	B9@.026	SF	1.48	.87	2.35
10" thick wall, (3.08 SF per CF)	B9@.031	SF	1.82	1.03	2.85
12" thick wall, (2.46 SF per CF)	B9@.042	SF	2.28	1.40	3.68

Add for grouting cores at 16" intervals, poured by hand

4" thick wall, (8.42 SF per CF)	B9@.012	SF	.67	.40	1.07
6" thick wall, (7.73 SF per CF)	B9@.013	SF	.73	.43	1.16
8" thick wall, (6.53 SF per CF)	B9@.016	SF	.86	.53	1.39
10" thick wall, (5.19 SF per CF)	B9@.019	SF	1.08	.63	1.71
12" thick wall, (4.21 SF per CF)	B9@.024	SF	1.33	.80	2.13

Add for grouting cores at 24" intervals, poured by hand

4" thick wall, (10.24 SF per CF)	B9@.008	SF	.55	.27	.82
6" thick wall, (9.02 SF per CF)	B9@.010	SF	.62	.33	.95
8" thick wall, (8.61 SF per CF)	B9@.012	SF	.65	.40	1.05
10" thick wall, (6.76 SF per CF)	B9@.014	SF	.83	.47	1.30
12" thick wall, (5.57 SF per CF)	B9@.018	SF	1.01	.60	1.61

Add for grouting cores at 32" intervals, poured by hand

4" thick wall, (11.66 SF per CF)	B9@.007	SF	.48	.23	.71
6" thick wall, (10.24 SF per CF)	B9@.008	SF	.55	.27	.82
8" thick wall, (9.97 SF per CF)	B9@.011	SF	.56	.37	.93
10" thick wall, (8.06 SF per CF)	B9@.013	SF	.70	.43	1.13
12" thick wall, (6.65 SF per CF)	B9@.016	SF	.84	.53	1.37

Add for grouting cores per vertical linear foot (VLF) of core, poured by hand

4" thick wall, (8.86 VLF per CF)	B9@.012	VLF	.95	.40	1.35
6" thick wall, (8.11 VLF per CF)	B9@.018	VLF	1.04	.60	1.64
8" thick wall, (6.73 VLF per CF)	B9@.025	VLF	1.25	.83	2.08
10" thick wall, (5.47 VLF per CF)	B9@.026	VLF	1.54	.87	2.41
12" thick wall, (4.37 VLF per CF)	B9@.029	VLF	1.92	.97	2.89

Add for pumped concrete, core grouting

— % 11.0 -7.0 —

Add for 2" thick caps, natural gray concrete

4" thick wall	B9@.027	LF	1.31	.90	2.21
6" thick wall	B9@.038	LF	1.56	1.27	2.83
8" thick wall	B9@.046	LF	1.82	1.53	3.35
12" thick wall	B9@.065	LF	2.64	2.17	4.81

Masonry, Block

	Craft@Hrs	Unit	Material	Labor	Total
Add for detailed block, 3/8" score					
Single score, one side	—	SF	.64	—	.64
Single score, two sides	—	SF	1.42	—	1.42
Multi-scores, one side	—	SF	.64	—	.64
Multi-scores, two sides	—	SF	1.42	—	1.42
Add for color block, any wall assembly					
Light colors	—	SF	.14	—	.14
Medium colors	—	SF	.22	—	.22
Dark colors	—	SF	.30	—	.30
Add for other than running bond	B9@.021	SF	—	.70	.70
Concrete block Foundations (footings) not included. Includes local delivery, mortar and 8% waste. Natural gray, medium weight, no reinforcing included. See also concrete block wall assemblies. Costs shown as Ea are for the block only, the mortar from the adjacent block will be sufficient for these blocks.					
4" wide units					
8" x 16", 1.125 per SF	B9@.085	SF	2.12	2.84	4.96
8" x 8", 2.25 per SF	B9@.093	SF	3.65	3.10	6.75
4" x 16", 2.25 per SF	B9@.093	SF	3.21	3.10	6.31
4" x 12", corner	B9@.052	Ea	1.39	1.73	3.12
4" x 8", 4.5 per SF, (half block)	B9@.106	SF	5.80	3.54	9.34
6" wide units					
8" x 16", 1.125 per SF	B9@.095	SF	2.64	3.17	5.81
8" x 16" corner	B9@.058	Ea	2.59	1.93	4.52
8" x 8", 2.25 per SF, (half block)	B9@.103	SF	4.71	3.44	8.15
4" x 16", 2.25 per SF	B9@.103	SF	4.00	3.44	7.44
4" x 14" corner	B9@.070	Ea	.91	2.34	3.25
4" x 8", 4.5 per SF, (half block)	B9@.114	SF	7.33	3.80	11.13
4" x 12" (3/4 block)	B9@.052	Ea	.86	1.73	2.59
8" wide units					
4" x 16", 2.25 per SF	B9@.141	SF	4.83	4.70	9.53
8" x 16", 1.125 per SF	B9@.111	SF	3.13	3.70	6.83
6" x 8", 3 per SF	B9@.137	SF	8.05	4.57	12.62
8" x 12" (3/4 block)	B9@.074	Ea	2.23	2.47	4.70
8" x 8" (half)	B9@.052	Ea	2.12	1.73	3.85
8" x 8" (lintel)	B9@.052	Ea	2.48	1.73	4.21
6" x 16", 1.5 per SF	B9@.117	SF	4.45	3.90	8.35
4" x 8" (half block)	B9@.053	Ea	1.72	1.77	3.49
12" wide units					
8" x 16", 1.125 per SF	B9@.148	SF	4.68	4.94	9.62
8" x 8" (half)	B9@.082	Ea	3.36	2.74	6.10
8" x 8" (lintel)	B9@.082	Ea	3.75	2.74	6.49
Add for high strength units	—	%	27.0	—	—
Add for lightweight block, typical	—	%	25.0	—	—
Deduct for lightweight block, labor	—	%	—	-7.0	—
Add for ladder type reinforcement	B9@.004	SF	.40	.13	.53
Add for 1/2" rebar 24" OC	B9@.004	SF	.25	.13	.38
Add for other than running bond	—	%	—	20.0	—
Add for detailed block, 3/8" score, typical prices					
Single score, one side	—	SF	.66	—	.66
Single score, two sides	—	SF	1.46	—	1.46
Multi-scores, one side	—	SF	.66	—	.66
Multi-scores, two sides	—	SF	1.46	—	1.46

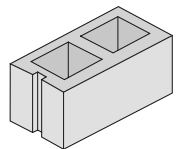
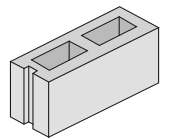

Masonry, Concrete Paver

	Craft@Hrs	Unit	Material	Labor	Total
Add for color block					
Light colors	—	SF	.13	—	.13
Medium colors	—	SF	.20	—	.20
Dark colors	—	SF	.25	—	.25
Split-face concrete block Textured block, medium weight, split one side, structural. Includes 8% waste and local delivery.					
8" wide, 4" x 16", 2.25 per SF	B9@.111	SF	7.56	3.70	11.26
8" wide, 8" x 16", 1.125 per SF	B9@.111	SF	3.95	3.70	7.65
12" wide, 8" x 8", 2.25 per SF	B9@.117	SF	10.90	3.90	14.80
12" wide, 8" x 16", 1.125 per SF	B9@.117	SF	5.62	3.90	9.52
Add for lightweight block	—	%	12.0	—	—
Add for color	—	SF	.41	—	.41
Add for mortar (at 7 cubic feet, per 100 square feet of wall)	—	SF	.81	—	.81
Concrete pavers Natural concrete 3/4" thick, including local delivery. Pavers installed in concrete bed but no concrete included.					
6" x 6", 4 per SF	B9@.150	SF	19.50	5.00	24.50
6" x 12", 2 per SF	B9@.150	SF	9.94	5.00	14.94
12" x 12", 1 per SF	B9@.150	SF	4.65	5.00	9.65
12" x 18", .667 per SF	B9@.150	SF	3.27	5.00	8.27
18" x 18", .444 per SF	B9@.150	SF	2.24	5.00	7.24
Add for light colors	—	SF	.63	—	.63
Add for dark colors	—	SF	1.87	—	1.87
Add for pavers with beach pebble surface	—	SF	1.24	—	1.24
Euro-style concrete pavers, 45mm thick, including compacted 1" sand bed, cobble finish, various colors.					
Walk or drive (2.5 units per SF)	B9@.150	SF	1.90	5.00	6.90
Steps, per LF of width	B9@.750	LF	2.87	25.00	27.87
Pool coping, per LF of coping edge	B9@.750	LF	4.16	25.00	29.16
Concrete screen block Natural color. Foundations and supports not included. Material costs include 8% waste. (Quantity per SF is shown in parentheses)					
Textured screen (no corebar defacements)					
4" x 12" x 12" (1 per SF)	B9@.211	SF	3.18	7.04	10.22
4" x 6" x 6" (3.68 per SF)	B9@.407	SF	3.74	13.60	17.34
4" x 8" x 8" (2.15 per SF)	B9@.285	SF	5.46	9.51	14.97
Four sided sculpture screens					
4" x 12" x 12" (1 per SF)	B9@.312	SF	3.15	10.40	13.55
Sculpture screens (patterned face, rug texture reverse)					
4" x 12" x 12" (1 per SF)	B9@.211	SF	4.23	7.04	11.27
4" x 16" x 16" (.57 per SF)	B9@.285	SF	4.20	9.51	13.71
4" x 16" x 12" (.75 per SF)	B9@.285	SF	4.47	9.51	13.98
Add for channel steel support (high rise)					
2" x 2" x 3/16"	—	LF	3.49	—	3.49
3" x 3" x 3/16"	—	LF	4.12	—	4.12
4" x 4" x 1/4"	—	LF	7.49	—	7.49
6" x 4" x 3/8"	—	LF	15.80	—	15.80

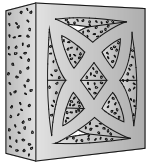

Masonry, Slump Block

Craft@Hrs Unit Material Labor Total

Concrete slump block Natural concrete color, 4" widths are veneer, no foundation or reinforcing included. Costs in material column include 8% waste. Heights to 6'. (Quantity per SF is shown in parentheses.)

4" x 4" x 8" (4.5 per SF)	B9@.267	SF	6.35	8.91	15.26
4" x 4" x 12" (3 per SF)	B9@.178	SF	4.48	5.94	10.42
4" x 4" x 16" (2.25 per SF)	B9@.133	SF	3.36	4.44	7.80
6" x 4" x 16" (2.25 per SF)	B9@.146	SF	5.29	4.87	10.16
6" x 6" x 16" (1.5 per SF)	B9@.107	SF	2.88	3.57	6.45
8" x 4" x 16" (2.25 per SF)	B9@.161	SF	5.45	5.37	10.82
8" x 6" x 16" (1.5 per SF)	B9@.117	SF	4.07	3.90	7.97
12" x 4" x 16" (2.25 per SF)	B9@.193	SF	9.25	6.44	15.69
12" x 6" x 16" (1.5 per SF)	B9@.128	SF	6.69	4.27	10.96

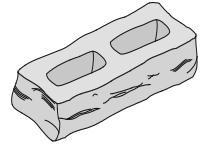

Cap or slab block, 2" thick, 16" long, .75 units per LF. No waste included

4" wide	B9@.160	LF	1.12	5.34	6.46
6" wide	B9@.160	LF	1.40	5.34	6.74
8" wide	B9@.160	LF	1.79	5.34	7.13

Add for curved slump block

4" wide, 2' or 4' diameter circle	—	%	125.0	25.0	—
8" wide, 2' or 4' diameter circle	—	%	150.0	20.0	—

Add for slump one side block

	—	SF	.05	—	.05
--	---	----	-----	---	-----

Add for light colors for slump block

	—	%	13.0	—	—
--	---	---	------	---	---

Add for darker colors for slump block

	—	%	25.0	—	—
--	---	---	------	---	---

Add for mortar for slump block. Cost includes normal waste

Using mortar, per cubic foot	—	CF	11.60	—	11.60
4" x 4" x 8" (4 CF per CSF)	—	SF	.46	—	.46
6" x 6" x 16" (4 CF per CSF)	—	SF	.46	—	.46
8" x 6" x 16" (5 CF per CSF)	—	SF	.58	—	.58
12" x 6" x 16" (7.5 CF per CSF)	—	SF	.87	—	.87

Adobe block Walls to 8', not including reinforcement or foundations, plus delivery, 4" high, 16" long,

2.25 blocks per SF, including 10% waste.

4" wide	B9@.206	SF	3.94	6.87	10.81
6" wide	B9@.233	SF	4.81	7.77	12.58
8" wide	B9@.238	SF	6.14	7.94	14.08
12" wide	B9@.267	SF	10.20	8.91	19.11
Add for reinforcement (24" OC both ways)	—	SF	.53	—	.53

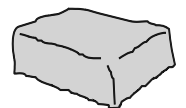

Flagstone Including concrete bed.

Veneer on walls, 3" thick	B9@.480	SF	6.38	16.00	22.38
Walks and porches, 2" thick	B9@.248	SF	3.15	8.27	11.42
Coping, 4" x 12"	B9@.272	SF	10.10	9.07	19.17
Steps, 6" risers	B9@.434	LF	3.61	14.50	18.11
Steps, 12" treads	B9@.455	LF	7.23	15.20	22.43

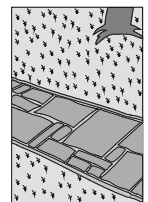

Flue lining Pumice, 1' lengths, delivered to 30 miles, including 8% waste.

8-1/2" round	B9@.148	Ea	7.52	4.94	12.46
8" x 13" oval	B9@.206	Ea	10.70	6.87	17.57
8" x 17" oval	B9@.228	Ea	12.00	7.61	19.61
10" x 17" oval	B9@.243	Ea	12.80	8.11	20.91
13" x 13" square	B9@.193	Ea	13.40	6.44	19.84
13" x 17" oval	B9@.193	Ea	13.40	6.44	19.84
13" x 21" oval	B9@.228	Ea	16.20	7.61	23.81

Masonry, Glass Block

	Craft@Hrs	Unit	Material	Labor	Total
17" x 17" square	B9@.228	Ea	17.00	7.61	24.61
17" x 21" oval	B9@.254	Ea	21.00	8.47	29.47
21" x 21" square	B9@.265	Ea	31.90	8.84	40.74

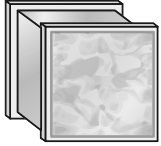

Glass block Costs include 6% for waste and local delivery. Add grout, spacer, sealant and reinforcing costs (accessories) and mortar from below. Labor cost includes laying the block, grouting and sealing. Costs assume a 100 SF job.

3-7/8" thick block, "cracked ice" faces

4" x 8", 4.5 per SF	B9@.392	SF	39.50	13.10	52.60
6" x 6", 4 per SF	B9@.376	SF	28.60	12.50	41.10
6" x 8", 3 per SF	B9@.336	SF	27.50	11.20	38.70
8" x 8", 2.25 per SF	B9@.296	SF	21.60	9.87	31.47
12" x 12", 1 per SF	B9@.211	SF	26.50	7.04	33.54
End blocks	B9@.125	SF	27.50	4.17	31.67
Double end blocks	B9@.125	SF	41.80	4.17	45.97
Corner blocks	B9@.125	SF	27.40	4.17	31.57
Deduct for 'diamond pattern' block	—	%	-4.2	—	—
Add for 'wavy face' block	—	%	7.0	—	—
Deduct for clear face block	—	%	-12.0	—	—
Add for frosted glass block	—	%	83.0	—	—
Add for colored glass blocks	—	%	70.0	—	—

3-1/8" thick Thinline® block, 'cracked ice' faces

4" x 8" 4.5 per SF	B9@.391	SF	29.00	13.00	42.00
4" x 8" 4.5 per SF	B9@.391	SF	27.60	13.00	40.60
6" x 8" 3 per SF	B9@.376	SF	20.70	12.50	33.20
8" x 8" 2.25 per SF	B9@.296	SF	18.10	9.87	27.97
End units, most sizes and styles	B9@.125	Ea	48.00	4.17	52.17
Corner units, most sizes and styles	B9@.125	Ea	51.00	4.17	55.17
Deduct for 'diamond pattern' block	—	%	-10.0	—	—
Deduct for 'wavy face' block	—	%	-0.5	—	—
Deduct for clear face block	—	%	-2.7	—	—
Add for frosted glass block	—	%	83.0	—	—
Add for colored glass blocks	—	%	70.0	—	—

Typical total cost of anchors, spacers, grout and sealer per SF

4" x 8" block	—	SF	9.47	—	9.47
6" x 6" block	—	SF	8.41	—	8.41
6" x 8" block	—	SF	6.59	—	6.59
8" x 8" block	—	SF	5.15	—	5.15
12" x 12" block	—	Ea	2.66	—	2.66
Add for block with heat and glare reducing insert	—	%	75.0	—	—
Deduct for 100 SF to 500 SF job	—	%	-5.0	—	—
Deduct for over 500 SF job to 1,000 SF job	—	%	-10.0	—	—
Deduct for over 1,000 SF job	—	%	-12.0	—	—

Accessories for glass block

Foam expansion strips	—	SF	1.47	—	1.47
Glass block anchors, package of 5	—	Ea	2.97	—	2.97
Panel anchors, 16" length	—	Ea	5.51	—	5.51
Reinforcing anchors, 36" length	—	Ea	7.12	—	7.12
Vertical spacers	—	Ea	1.88	—	1.88
Horizontal spacers, 40" length	—	Ea	8.23	—	8.23
Track spacers, 31" length	—	Ea	9.89	—	9.89
Perimeter channel, 48" length	—	Ea	16.00	—	16.00
Sealant, 10.3 oz	—	Ea	7.37	—	7.37
Block spacers	—	Ea	.59	—	.59

Masonry Accessories

	Craft@Hrs	Unit	Material	Labor	Total
Mortar for glass block. White cement mix (1 part white cement, 1/2 part hydrated lime, 2-1/4 to 3 parts #20 or #30 silica sand)					
White cement mix	—	CF	44.80	—	44.80
1/4" mortar joints, 3-7/8" thick block, white cement mix					
4" x 8" block	—	SF	2.09	—	2.09
6" x 6" block	—	SF	2.04	—	2.04
6" x 8" block	—	SF	1.90	—	1.90
8" x 8" block	—	SF	1.52	—	1.52
12" x 12" block	—	SF	1.04	—	1.04
1/4" mortar joints, 3" and 3-1/8" thick block, white cement mix					
4" x 8" block	—	SF	1.71	—	1.71
6" x 8" block	—	SF	1.66	—	1.66
8" x 8" block	—	SF	1.23	—	1.23
Masonry Accessories					
Non-fibered masonry waterproofing for below-grade application					
Gallon covers 80 SF	B9@.688	Gal	27.50	23.00	50.50
Glass reinforcing mesh	—	SF	.13	—	.13
Lime					
Hydrated (builders)					
25 lb sack	—	Sack	6.85	—	6.85
50 lb sack, Type S	—	Sack	11.20	—	11.20
50 lb sack, white lime	—	Sack	9.18	—	9.18
70 lb sack, portland lime	—	Sack	11.00	—	11.00
50 lb sack, athletic field marker	—	Sack	13.30	—	13.30
Silica sand, #30, 100 lb sack	—	Sack	9.54	—	9.54
Mortar colors					
Standard colors, 2 lb bag	—	Lb	4.63	—	4.63
Premium colors, 2 lb bag	—	Lb	8.13	—	8.13

Masonry, Mortar

Craft@Hrs Unit Material Labor Total

Trowel-ready mortar (factory prepared, ready to use), 30 hour life. Deposit required on container, local delivery included. Type S mortar has high compressive strength (1,800 PSI) and high tensile bond strength. Type S is made from 2 parts portland cement, 1 part hydrated lime and 9 parts sand, and offers a longer board life. Type M mortar is made with 3 parts of Portland cement, 1 part lime and 12 parts sand. Type M has a high compressive strength (at least 2,500 PSI) and is recommended for masonry in structural walls and masonry below grade such as foundations, retaining walls, sidewalks and driveways. Type N is a medium compressive-strength (750 PSI) mortar made of 1 part Portland cement, 1 part lime and 6 parts sand. Type N is recommended for exterior above-grade walls exposed to severe weather, such as chimneys.

Type S natural mortar, 1/3 CY	—	Ea	148.00	—	148.00
Type M natural mortar, 1/3 CY	—	Ea	238.00	—	238.00
Add to natural mortar for colored, 1/3 CY	—	Ea	29.80	—	29.80
Type S white mortar, 1/3 CY	—	Ea	236.00	—	236.00

Trowel-ready mortar, cost per square foot of wall, 3/8" joint

4" x 4" x 8" brick wall	—	SF	.68	—	.68
8" x 8" x 16" block wall	—	SF	.55	—	.55

Dry mortar mix

Type S, 94 lb sack	—	Sack	6.92	—	6.92
Type N, 60 lb sack	—	Sack	5.95	—	5.95

Hi-rise channel reinforcing steel (hat channel)

2" x 2" x 3/16"	—	LF	2.93	—	2.93
3" x 3" x 3/16"	—	LF	3.48	—	3.48
4" x 4" x 1/4"	—	LF	6.89	—	6.89
6" x 4" x 3/8"	—	LF	13.50	—	13.50
Welding	SW@.176	Ea	—	7.49	7.49
Cutting	SW@.088	Ea	—	3.74	3.74
Flanges, drill one hole, weld	SW@.272	Ea	—	11.60	11.60
Additional holes	SW@.028	Ea	—	1.19	1.19

Expansion joints

1/2" x 3-1/2"	—	LF	.39	—	.39
1/4" x 3-1/2"	—	LF	.30	—	.30
1/2" x 4"	—	LF	.34	—	.34

Wall anchors, 1-3/4" x 24"

—	—	Ea	5.17	—	5.17
---	---	----	------	---	------

Dur-O-Wal reinforcing, Ladur or standard, 10' lengths

3" wide or 4" wide wall	—	LF	.46	—	.46
6" wide wall	—	LF	.48	—	.48
8" wide wall	—	LF	.50	—	.50
10" wide wall	—	LF	.53	—	.53
12" wide wall	—	LF	.55	—	.55

Wired adobe blocks

2" x 2"	—	Ea	.45	—	.45
3" x 3"	—	Ea	.55	—	.55

Tie wire, black, 16.5 gauge

Roll, 400'	—	Ea	8.59	—	8.59
------------	---	----	------	---	------

Wall ties, 22 gauge

—	—	M	189.00	—	189.00
---	---	---	--------	---	--------

Wall ties, 28 gauge

—	—	M	166.00	—	166.00
---	---	---	--------	---	--------

Angle iron

3" x 3" x 3/16"	—	LF	7.55	—	7.55
4" x 4" x 1/4"	—	LF	13.90	—	13.90
6" x 4" x 3/8"	—	LF	20.20	—	20.20

Post anchors (straps)

4" x 4" x 10"	—	Ea	14.10	—	14.10
4" x 4" x 16"	—	Ea	31.80	—	31.80

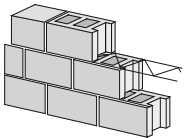

Mats, Runners and Treads

	Craft@Hrs	Unit	Material	Labor	Total
Masonry, Subcontract Typical prices.					
Fireplace chimneys, masonry only. Height above firebox shown.					
5' high chimney (3' opening)	—	Ea	—	—	2,890.00
13' high chimney (3' opening)	—	Ea	—	—	3,400.00
Floors					
Flagstone	—	SF	—	—	13.30
Patio tile	—	SF	—	—	10.40
Pavers	—	SF	—	—	11.30
Quarry tile, unglazed	—	SF	—	—	14.60
Mats, Runners and Treads Koffler Products.					
Mats					
Vinyl link mats, closed link, 1/2" thick, including nosing					
Solid colors incl. black 28" x 36"	B1@.167	Ea	196.00	5.70	201.70
For 9" to 12" letters add	—	Ea	28.90	—	28.90
Steel link mats, 3/8" deep, 1" mesh					
16" x 24"	B1@.501	Ea	19.50	17.10	36.60
22" x 36"	B1@.501	Ea	37.60	17.10	54.70
30" x 48"	B1@.501	Ea	65.30	17.10	82.40
36" x 54"	B1@.501	Ea	90.00	17.10	107.10
36" x 72"	B1@.501	Ea	119.00	17.10	136.10
Runners					
Corrugated rubber runner, cut lengths, 2', 3', 4' widths					
1/8" thick, black	B1@.060	SF	5.32	2.05	7.37
Corrugated or round ribbed vinyl runner, 1/8" thick, 2', 3', or 4' wide, cut lengths, flame resistant					
Black corrugated	B1@.060	SF	3.26	2.05	5.31
Black or brown, round ribbed	B1@.060	SF	3.13	2.05	5.18
Deduct for full rolls (100 LF)	—	%	-10.0	—	—
Safety strips, non-slip strips, press-on abrasive, black, 1/16" thick					
3/4" x 24", box of 50	B1@.080	Ea	1.47	2.73	4.20
6" x 24" cleats	B1@.080	Ea	9.88	2.73	12.61
Treads					
Stair treads, homogeneous rubber, 9/64" thick, 1-1/2" nosing, 12-1/4" deep					
Diamond design, marbleized, medium duty	B1@.080	LF	18.80	2.73	21.53
Plain, with abrasive strips	B1@.080	LF	17.30	2.73	20.03
Matching cove riser	B1@.080	LF	8.85	2.73	11.58

Medicine Cabinets

Recessed or surface mount medicine cabinets, hinged door, no lighting					
Basic steel-frame mirror cabinet with polystyrene body, magnetic catch, three fixed shelves					
14" x 18"	BC@.850	Ea	16.70	32.00	48.70
Basic flat glass panel cabinet with enameled steel body, concealed brass hinges, one fixed shelf					
15" x 19"	BC@.850	Ea	33.30	32.00	65.30
Better quality etched and beveled mirror door cabinet, 2 adjustable shelves, polished brass knobs					
25" x 26"	BC@.850	Ea	133.00	32.00	165.00
Corner-mount frameless cabinet, one beveled mirror door, 2 adjustable shelves					
14" x 26"	BC@.850	Ea	127.00	32.00	159.00
Surface mount medicine cabinets, hinged door, no lighting					
Tri-view frame cabinet, flat glass panel, 2 adjustable shelves, brass exposed hinges					
24" x 24"	BC@.850	Ea	85.00	32.00	117.00
30" x 29"	BC@.941	Ea	124.00	35.40	159.40
36" x 29"	BC@.941	Ea	119.00	35.40	154.40

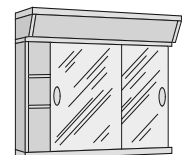
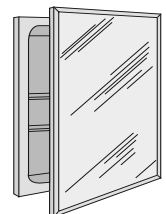









Meter Boxes

	Craft@Hrs	Unit	Material	Labor	Total
Beveled tri-view frame cabinet, flat glass panel, 2 adjustable shelves, concealed adjustable hinges					
24" x 26"	BC@.850	Ea	99.00	32.00	131.00
29" x 25"	BC@.941	Ea	110.00	35.40	145.40
36" x 30"	BC@.941	Ea	143.00	35.40	178.40
48" x 30"	BC@.941	Ea	166.00	35.40	201.40
Oval smoked bevel mirror, frameless swing door					
14" x 18"	BC@.850	Ea	112.00	32.00	144.00
All wood cabinets, 2 shelves, magnetic door latch, surface mount					
15" x 25", oak finish	BC@.850	Ea	38.90	32.00	70.90
15" x 25", white finish	BC@.850	Ea	38.10	32.00	70.10
Matching light bars for medicine cabinets, including electrical connection					
4 lights	BE@1.50	Ea	54.80	61.50	116.30
5 lights	BE@1.50	Ea	68.20	61.50	129.70
6 lights	BE@1.50	Ea	81.90	61.50	143.40
7 lights	BE@1.50	Ea	114.00	61.50	175.50
Meter Boxes Precast concrete, FOB manufacturer, inside dimension, approximately 100 to 190 lbs. each.					
13-1/4" x 19-1/8" x 11" deep					
With 1 piece concrete cover	BL@.334	Ea	29.40	10.20	39.60
With metal cover (cast iron)	BL@.334	Ea	41.30	10.20	51.50
14-5/8" x 19-3/4" x 11" deep					
With 1 piece concrete cover	BL@.334	Ea	23.80	10.20	34.00
With metal cover (cast iron)	BL@.334	Ea	42.20	10.20	52.40
15-3/4" x 22-3/4" x 11" deep					
With 1 piece concrete cover	BL@.334	Ea	43.20	10.20	53.40
With metal cover (cast iron)	BL@.334	Ea	76.40	10.20	86.60
Add hinged or reading lid, concrete cover	—	Ea	9.22	—	9.22
Plastic meter and valve boxes					
Standard 16" x 10-3/4" x 12" deep	BL@.167	Ea	21.00	5.10	26.10
Jumbo 20-1/4" x 14-1/2" x 12" deep	BL@.167	Ea	60.00	5.10	65.10
Round pit box, 10" diameter x 12" deep	BL@.167	Ea	15.20	5.10	20.30
Mirrors See also Bathroom Accessories.					
Door mirrors, polished edge					
12" wide x 48" high	BG@.251	Ea	23.30	9.15	32.45
16" wide x 60" high	BG@.301	Ea	36.00	11.00	47.00
18" wide x 68" high	BG@.331	Ea	43.30	12.10	55.40
Vanity mirrors, polished edge					
24" wide x 36" high	BG@.251	Ea	36.50	9.15	45.65
36" wide x 36" high	BG@.301	Ea	50.90	11.00	61.90
36" wide x 42" high	BG@.331	Ea	58.10	12.10	70.20
48" wide x 36" high	BG@.331	Ea	67.10	12.10	79.20
60" wide x 36" high	BG@.331	Ea	85.00	12.10	97.10
72" wide x 36" high	BG@.450	Ea	215.00	16.40	231.40
96" wide x 48" high	BG@.450	Ea	389.00	16.40	405.40
Frosted oval mirrors, floral design, polished edge					
23" x 29"	BG@.251	Ea	57.60	9.15	66.75
23" x 36"	BG@.251	Ea	86.30	9.15	95.45
27" x 30", decorative chrome frame	BG@.251	Ea	167.00	9.15	176.15
Mirror arches (radius, top edge)					
23" x 35" high, frosted pattern	BG@.251	Ea	70.30	9.15	79.45
Framed gallery mirrors					
30" x 36", sandalwood frame	BG@.450	Ea	156.00	16.40	172.40
30" x 32", metal frame	BG@.450	Ea	184.00	16.40	200.40
36" x 32", metal frame	BG@.450	Ea	201.00	16.40	217.40
42" x 34", antique black frame	BG@.450	Ea	229.00	16.40	245.40

Molding, Hardwood

Moldings Unfinished. Material costs include 5% waste. Labor costs are for typical installation only. (For installation costs of Hardwood Molding, see Softwood Moldings starting on next page under Moldings.)

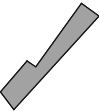
Hardwood molding

	Unit	Oak	Poplar	Birch		
Base						
3/8" x 2-3/4"	LF	1.46	1.34	3.71		
1/2" x 3-1/4"	LF	2.35	1.78	4.94		
Base shoe, 1/2" x 3/4"	LF	.66	.49	1.24		
Casing						
1/2" x 2-1/4"	LF	1.41	1.34	3.71		
5/8" x 2-1/2"	LF	1.72	1.70	4.73		
Cap, 3/4" x 1-1/4"	LF	2.26	.89	2.47		
Crown, 9/16" x 3-5/8"	LF	3.02	1.78	4.94		
Cove						
1/2" x 1/2"	LF	1.46	.46	1.24		
3/4" x 3/4"	LF	.94	.46	1.24		
Corner, outside						
3/4" x 3/4"	LF	1.55	.49	1.24		
Round edge stop, 3/8" x 1-1/4"	LF	1.23	.89	2.47		
Chair rail, 9/16" x 2-5/8"	LF	2.14	1.34	3.71		
Quarter round						
1/2" x 1/2"	LF	.75	.44	1.24		
3/4" x 3/4"	LF	.88	.49	1.24		
Battens, 1/4" x 3/4"	LF	1.04	.49	1.24		
Door trim sets, 16'8" total length						
3/4" x 2-1/2" casing	Ea	29.20	27.20	36.70		
3/4" x 3" casing	Ea	36.40	30.80	41.10		
3/4" x 3-1/2" casing	Ea	45.60	37.00	45.60		







	Craft@Hrs	Unit	Material	Labor	Total
Oak threshold, LF of threshold					
5/8" x 3-1/2" or 3/4" x 3-1/2"	BC@.174	LF	3.91	6.55	10.46
5/8" x 5-5/8"	BC@.174	LF	7.47	6.55	14.02
5/8" x 4-5/8"	BC@.174	LF	5.68	6.55	12.23

Redwood molding



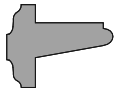







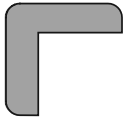

Band molding, 3/4" x 5/16"	BC@.030	LF	1.74	1.13	2.87
Battens and lattice					
5/16" x 1-1/4"	BC@.026	LF	.99	.98	1.97
5/16" x 1-5/8"	BC@.026	LF	1.00	.98	1.98
5/16" x 2-1/2"	BC@.026	LF	1.56	.98	2.54
5/16" x 3-1/2"	BC@.026	LF	1.58	.98	2.56
3/8" x 2-1/2"	BC@.026	LF	2.62	.98	3.60
Brick mold, 1-1/2" x 1-1/2"	BC@.026	LF	3.39	.98	4.37
Drip cap – water table					
1-5/8" x 2-1/2" (no lip)	BC@.060	LF	4.32	2.26	6.58
1-5/8" x 2-1/2"	BC@.060	LF	4.39	2.26	6.65



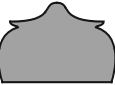

Molding, Softwood

		Craft@Hrs	Unit	Material	Labor	Total
	Quarter round, 3/4" x 3/4"	BC@.026	LF	2.06	.98	3.04
	Rabbeted siding mold, 1-1/8" x 1-5/8"	BC@.026	LF	2.66	.98	3.64
	S4S (rectangular)					
	11/16" x 11/16"	BC@.026	LF	1.28	.98	2.26
	1" x 2"	BC@.026	LF	1.93	.98	2.91
	1" x 3"	BC@.026	LF	2.85	.98	3.83
	1" x 4"	BC@.026	LF	3.64	.98	4.62
	Stucco mold					
	13/16" x 1-3/8"	BC@.026	LF	1.43	.98	2.41
	13/16" x 1 1/2"	BC@.026	LF	1.45	.98	2.43
	Window sill, 2" x 8"	BC@.043	LF	18.60	1.62	20.22
Softwood molding, pine (Labor costs here can also be used for hardwood moldings in the previous section.)						
	Astragal molding					
	For 1-3/8" x 7' doors	BC@.032	LF	1.61	1.21	2.82
	For 1-3/4" x 7' doors	BC@.032	LF	4.91	1.21	6.12
	Base (all patterns)					
	7/16" x 7/16"	BC@.016	LF	.98	.60	1.58
	7/16" x 1-1/4"	BC@.016	LF	1.04	.60	1.64
	3/8" x 3"	BC@.016	LF	1.27	.60	1.87
	1/2" x 2-1/4"	BC@.016	LF	1.52	.60	2.12
	1/2" x 3-1/4"	BC@.016	LF	1.68	.60	2.28
	17/32" x 3-7/32"	BC@.016	LF	1.85	.60	2.45
	Base (combination or cove)					
	11/16" x 1-1/8"	BC@.016	LF	1.30	.60	1.90
	9/16" x 1-3/4"	BC@.016	LF	1.82	.60	2.42
	1/2" x 3-1/4"	BC@.016	LF	2.06	.60	2.66
	Base shoe					
	1/2" x 3/4"	BC@.016	LF	.45	.60	1.05
	Casing (all patterns)					
	1/2" x 1-5/8"	BC@.023	LF	1.34	.87	2.21
	11/16" x 2-1/4"	BC@.023	LF	3.53	.87	4.40
	11/16" x 3-1/4"	BC@.023	LF	1.99	.87	2.86
	11/16" x 3-1/2"	BC@.023	LF	2.37	.87	3.24
	Chair rail					
	1/2" x 1-1/2"	BC@.021	LF	1.38	.79	2.17
	11/16" x 2-1/2"	BC@.021	LF	1.96	.79	2.75
	Chamfer strip, 3/4" x 3/4"	BC@.016	LF	.28	.60	.88
	Corner bead (outside corner molding)					
	11/16" x 11/16"	BC@.016	LF	.72	.60	1.32
	3/4" x 3/4"	BC@.016	LF	.94	.60	1.54
	1-1/8" x 1-1/8"	BC@.016	LF	1.37	.60	1.97

Molding, Softwood

	Craft@Hrs	Unit	Material	Labor	Total	
Cove molding, solid						
3/8" x 3/8"	BC@.020	LF	.52	.75	1.27	
1/2" x 1/2"	BC@.020	LF	.68	.75	1.43	
11/16" x 11/16"	BC@.020	LF	.89	.75	1.64	
3/4" x 3/4"	BC@.020	LF	1.02	.75	1.77	
1-1/2" x 1-1/2"	BC@.020	LF	1.43	.75	2.18	
Cove molding, sprung						
9/16" x 1-3/4"	BC@.020	LF	1.31	.75	2.06	
5/8" x 3/4"	BC@.020	LF	.99	.75	1.74	
Crown or bed molding						
9/16" x 1-5/8"	BC@.044	LF	.81	1.66	2.47	
9/16" x 2-3/4"	BC@.044	LF	1.63	1.66	3.29	
9/16" x 1-3/4"	BC@.044	LF	.98	1.66	2.64	
9/16" x 2-5/8"	BC@.044	LF	2.29	1.66	3.95	
9/16" x 3-5/8"	BC@.044	LF	2.12	1.66	3.78	
Add for special cutting, any crown molding shown:						
Inside corner, using coping saw	BC@.167	Ea	—	6.29	6.29	
Outside corners, using miter saw	BC@.083	Ea	—	3.13	3.13	
Drip cap (water table molding or bar nosing)						
1-1/16" x 1-5/8"	BC@.060	LF	2.95	2.26	5.21	
1-1/16" x 2"	BC@.060	LF	3.27	2.26	5.53	
Drip molding						
3/4" x 1-1/4"	BC@.030	LF	.90	1.13	2.03	
Glass bead						
1/2" x 1-3/8"	BC@.016	LF	.76	.60	1.36	
Handrail, fir						
1-1/2" x 2-1/4"	BC@.060	LF	3.13	2.26	5.39	
1-7/16" x 1-3/4"	BC@.060	LF	3.11	2.26	5.37	
Lattice						
1/4" x 1-1/8"	BC@.016	LF	.47	.60	1.07	
1/4" x 1-1/2"	BC@.016	LF	.83	.60	1.43	
5/16" x 1-3/8"	BC@.016	LF	1.18	.60	1.78	
5/16" x 1-3/4"	BC@.016	LF	1.38	.60	1.98	
Mullion casing						
3/8" x 2"	BC@.016	LF	1.65	.60	2.25	
Panel molding						
3/8" x 5/8"	BC@.030	LF	1.01	1.13	2.14	
5/8" x 1-1/4"	BC@.030	LF	1.08	1.13	2.21	
3/4" x 1"	BC@.030	LF	1.44	1.13	2.57	
11/16" x 1-5/8"	BC@.030	LF	1.22	1.13	2.35	
3/4" x 2"	BC@.030	LF	1.61	1.13	2.74	
Parting bead						
3/8" x 3/4"	BC@.016	LF	.83	.60	1.43	
Picture frame mold						
3/4" x 3/4"	BC@.040	LF	1.51	1.51	3.02	
7/8" x 1-1/2"	BC@.040	LF	1.93	1.51	3.44	
Plaster ground						
3/4" x 7/8"	BC@.010	LF	.79	.38	1.17	

Molding, Softwood

	Craft@Hrs	Unit	Material	Labor	Total
Quarter round					
					
1/4" x 1/4"	BC@.016	LF	.48	.60	1.08
1/2" x 1/2"	BC@.016	LF	.52	.60	1.12
21/32" x 21/32"	BC@.016	LF	.62	.60	1.22
11/16" x 11/16"	BC@.016	LF	.65	.60	1.25
3/4" x 3/4"	BC@.016	LF	1.35	.60	1.95
1" x 1-11/16"	BC@.016	LF	1.32	.60	1.92
Half round					
					
1/4" x 1/2" or 5/16" x 5/8"	BC@.016	LF	1.06	.60	1.66
3/8" x 3/4" or 1/2" x 1"	BC@.016	LF	.70	.60	1.30
3/4" x 1-1/2"	BC@.016	LF	1.38	.60	1.98
Full round					
1/2" or 3/4" diameter	BC@.016	LF	.98	.60	1.58
1-1/4" or 1-3/8" diameter	BC@.016	LF	2.28	.60	2.88
1" diameter	BC@.016	LF	1.17	.60	1.77
1-1/2" diameter	BC@.016	LF	2.31	.60	2.91
2" diameter	BC@.016	LF	3.31	.60	3.91
S4S (rectangular)					
					
7/16" x 1-5/8", pine	BC@.020	Ea	1.10	.75	1.85
7/16" x 2-1/2", pine	BC@.020	Ea	1.77	.75	2.52
7/16" x 2-5/8", pine	BC@.020	Ea	1.76	.75	2.51
7/16" x 3-1/2", pine	BC@.020	Ea	3.03	.75	3.78
1/2" x 3/4", pine	BC@.016	Ea	.63	.60	1.23
1/2" x 2-1/2", pine	BC@.020	Ea	1.94	.75	2.69
1/2" x 3-1/2", pine	BC@.020	Ea	3.13	.75	3.88
11/16" x 11/16", pine	BC@.016	Ea	.89	.60	1.49
11/16" x 1-5/8", pine	BC@.016	Ea	1.56	.60	2.16
11/16" x 1-3/4", pine	BC@.016	Ea	1.60	.60	2.20
11/16" x 2-1/2", pine	BC@.020	Ea	2.96	.75	3.71
3/4" x 3/4", pine	BC@.016	Ea	1.06	.60	1.66
1-1/16" x 1-3/4", pine	BC@.016	Ea	2.52	.60	3.12
Sash bar					
7/8" x 1-3/8"	BC@.016	LF	1.08	.60	1.68
Screen molding					
1/4" x 3/4" beaded	BC@.016	LF	.46	.60	1.06
1/4" x 3/4" flat or insert	BC@.016	LF	.57	.60	1.17
3/8" x 3/4" clover leaf	BC@.016	LF	.63	.60	1.23
Square molding					
1/2" x 1/2"	BC@.016	LF	.67	.60	1.27
3/4" x 3/4"	BC@.016	LF	1.12	.60	1.72
1" x 1"	BC@.016	LF	1.34	.60	1.94
2" x 2"	BC@.016	LF	2.64	.60	3.24
Stops, round edge					
3/8" x 7/8"	BC@.025	LF	.46	.94	1.40
3/8" x 1-1/4"	BC@.025	LF	.80	.94	1.74
3/8" x 1-3/8"	BC@.025	LF	.76	.94	1.70
3/8" x 1-5/8" or 1/2" x 3/4"	BC@.025	LF	.76	.94	1.70
7/16" x 3/4"	BC@.025	LF	.76	.94	1.70
7/16" x 1-1/4"	BC@.025	LF	1.19	.94	2.13
7/16" x 1-5/8"	BC@.025	LF	1.26	.94	2.20
Wainscot cap					
5/8" x 1-1/4" or 1/2" x 1-1/2"	BC@.016	LF	1.24	.60	1.84

Molding, White Vinyl

	Craft@Hrs	Unit	Material	Labor	Total
Window stool, beveled					
11/16" x 2-1/4"	BC@.037	LF	2.98	1.39	4.37
11/16" x 2-1/2"	BC@.037	LF	1.96	1.39	3.35
1" x 3-1/2"	BC@.037	LF	4.66	1.39	6.05
1" x 5-1/2"	BC@.037	LF	7.17	1.39	8.56
Window stool, flat					
11/16" x 4-5/8"	BC@.037	LF	2.90	1.39	4.29
1" x 5-1/2"	BC@.037	LF	6.55	1.39	7.94
Medium density fiberboard molding Primed, ready for painting.					
Base, 9/16" x 3-1/4"	BC@.012	LF	1.52	.45	1.97
Base, 1/2" x 4-1/4"	BC@.012	LF	1.81	.45	2.26
Casing, 5/8" x 2-1/2"	BC@.016	LF	1.04	.60	1.64
Door casing set, fluted, 17' x 3/4" x 2-1/4"	BC@.272	Ea	33.70	10.20	43.90
Chair rail, 9/16" x 3"	BC@.015	LF	1.99	.56	2.55
Corner, bullnose, 2-1/4" x 2-1/4"	BC@.025	LF	1.04	.94	1.98
Crown, 11/16" x 3-1/2"	BC@.025	LF	1.09	.94	2.03
Crown inside or outside corner block, 3/4" x 6"	BC@.125	Ea	21.90	4.71	26.61
Plinth block, 1" x 3-3/4"	BC@.125	Ea	4.47	4.71	9.18
White vinyl molding Unfinished.					
Backband casing	BC@.016	LF	2.48	.60	3.08
Base cap, 11/16" x 1-1/8"	BC@.009	LF	.95	.34	1.29
Bead, 9/16" x 1-3/4"	BC@.016	LF	1.04	.60	1.64
Blind stop	BC@.016	LF	.95	.60	1.55
Casing, 5/8" x 2-1/2"	BC@.023	LF	1.05	.87	1.92
Crown, 1/2" x 3-1/4"	BC@.044	LF	2.51	1.66	4.17
Dentil, 27/32" x 5-7/8"	BC@.016	LF	5.01	.60	5.61
Dentil, 27/32" x 4-1/8"	BC@.016	LF	1.91	.60	2.51
Drip cap, 11/16" x 1-5/8"	BC@.016	LF	1.53	.60	2.13
Exterior bead 3/16" x 1/2"	BC@.016	LF	.38	.60	.98
Flat utility trim	BC@.023	LF	2.41	.87	3.28
Quarter round, 3/4" x 3/4" x 12'	BC@.016	LF	.82	.60	1.42
Shingle molding, 11/16" x 1-3/4"	BC@.016	LF	1.73	.60	2.33
Extruded polymer molding Factory finished.					
Bead, Brite White	BC@.016	LF	.61	.60	1.21
Bead, Cherry/Mahogany	BC@.016	LF	.35	.60	.95
Bead, Cinnamon Chestnut	BC@.016	LF	.48	.60	1.08
Bed mold, Brite White	BC@.016	LF	.88	.60	1.48
Bed mold, Cherry/Mahogany	BC@.016	LF	.67	.60	1.27
Bed mold, Cinnamon Chestnut	BC@.016	LF	.90	.60	1.50
Casing and base, Brite White	BC@.023	LF	.72	.87	1.59
Casing and base, Cherry/Mahogany	BC@.023	LF	.92	.87	1.79
Casing and base, Cinnamon Chestnut	BC@.023	LF	.90	.87	1.77
Outside corner, Brite White	BC@.016	LF	.54	.60	1.14
Outside corner, Cherry/Mahogany	BC@.016	LF	.35	.60	.95
Outside corner, Cinnamon Chestnut	BC@.016	LF	.46	.60	1.06
Plywood cap, Brite White	BC@.016	LF	.78	.60	1.38
Shoe, Brite White	BC@.016	LF	.42	.60	1.02
Shoe, Cherry/Mahogany	BC@.016	LF	.35	.60	.95
Shoe, Cinnamon Chestnut	BC@.016	LF	.46	.60	1.06
Stop, Brite White	BC@.025	LF	.46	.94	1.40
Stop, Cinnamon Chestnut	BC@.025	LF	.46	.94	1.40

Nails and Fasteners

Nail sizes are usually identified by the "penny," abbreviated "d." Use the following figures to estimate nail quantities for framing:

Sills and plates – 8 pounds of 10d, 16d and 20d nails per MBF

Walls and partition studs – 10 pounds of 10d and 16d nails per MBF

2" x 6" or 2" x 8" joists and rafters – 9 pounds of 16d nails per MBF

2" x 10" or 2" x 12" joist and rafters – 7 pounds of 16d nails per MBF

Sheathing to 3/8" thick – 10 pounds of 6d nails per MSF

Sheathing over 3/8" thick – 20 pounds of 8d nails per MSF

Siding – 25 pounds of 8d nails per MSF

	Unit	Galvanized	Bright
Common nails Bright nails are tumbled to remove debris and have a polished appearance. Galvanized nails are zinc coated to protect against corrosion and have a dull sheen. Cost per box except as noted.			
3 penny, 1-1/4", 1-pound box, 568 nails	Box	5.51	4.50
4 penny, 1-1/2", 1-pound box, 316 nails	Box	5.50	4.30
4 penny, 1-1/2", 5-pound box, 2,840 nails	Box	19.30	15.80
5 penny, 1-3/4", 1-pound box, 271 nails	Box	—	4.81
6 penny, 2", 1-pound box, 181 nails	Box	5.50	—
6 penny, 2", 5-pound box, 905 nails	Box	19.30	15.10
6 penny, 2", 30-pound box, 5,430 nails	Box	63.20	47.30
6 penny, 2", 50-pound box, 9,050 nails	Box	73.30	—
7 penny, 2-1/2", 5-pound box, 805 nails	Box	20.50	—
7 penny, 2-1/2", 50-pound box, 8,050 nails	Box	83.70	—
8 penny, 2-1/2", 1-pound box, 106 nails	Box	5.42	4.35
8 penny, 2-1/2", 5-pound box, 530 nails	Box	19.30	15.10
8 penny, 2-1/2", 30-pound box, 3,180 nails	Box	69.10	52.10
8 penny, 2-1/2", 50-pound box, 5,300 nails	Box	—	63.20
10 penny, 3", 1-pound box, 69 nails	Box	5.50	4.35
10 penny, 3", 5-pound box, 345 nails	Box	19.30	15.10
10 penny, 3", 30-pound box, 2,070 nails	Box	69.10	51.20
10 penny, 3", 50-pound box, 3,450 nails	Box	82.30	60.90
12 penny, 3-1/4", 1-pound box, 64 nails	Box	5.36	—
12 penny, 3-1/4", 5-pound box, 320 nails	Box	19.30	15.00
12 penny, 3-1/4", 30-pound box, 1,920 nails	Box	68.60	52.90
12 penny, 3-1/4", 50-pound box, 3,200 nails	Box	—	65.10
16 penny, 3-1/2", 1-pound box, 49 nails	Box	5.44	4.38
16 penny, 3-1/2", 5-pound box, 245 nails	Box	19.50	15.30
16 penny, 3-1/2", 30-pound box, 1,470 nails	Box	80.80	52.90
16 penny, 3-1/2", 50-pound box, 2,450 nails	Box	69.40	64.10
20 penny, 4", 1-pound box, 31 nails	Box	5.50	4.35
20 penny, 4", 5-pound box, 155 nails	Box	19.30	15.20
40 penny, 5", per nail, 18 per pound	Ea	.07	.06
60 penny, 6", per nail, 11 per pound	Ea	.20	.09
60 penny, 6", 30-pound box, 330 nails	Box	—	53.60

Box nails Box nails are thinner and about 1/8" shorter than common nails of the same nominal size. Points are blunter to reduce wood splitting. Use box nails for molding and trim and when the lumber is dry or brittle. Cost per box.

3 penny, 1-1/4", 1-pound box, 1,010 nails	Box	5.86	4.81
3 penny, 1-1/4", 5-pound box, 5,050 nails	Box	20.50	—
4 penny, 1-1/2", 1-pound box, 473 nails	Box	5.77	4.81
4 penny, 1-1/2", 5-pound box, 2,365 nails	Box	21.20	—

Nails

	Unit	Galvanized	Bright
5 penny, 1-3/4", 1-pound box, 406 nails	Box	5.86	—
5 penny, 1-3/4", 5-pound box, 2,030 nails	Box	20.60	—
6 penny, 2", 1-pound box, 236 nails	Box	5.81	4.81
6 penny, 2", 5-pound box, 1,180 nails	Box	20.30	16.50
7 penny, 2-1/4", 1-pound box, 210 nails	Box	5.86	—
8 penny, 2-1/2", 1-pound box, 145 nails	Box	5.81	4.81
8 penny, 2-1/2", 5-pound box, 725 nails	Box	20.30	16.50
8 penny, 2-1/2", 30-pound box, 4,350 nails	Box	70.70	—
10 penny, 3", 1-pound box, 132 nails	Box	5.84	4.81
10 penny, 3", 5-pound box, 660 nails	Box	20.50	16.60
12 penny, 3-1/4", 1-pound box, 94 nails	Box	5.68	4.84
12 penny, 3-1/4", 5-pound box, 470 nails	Box	20.30	—
16 penny, 3-1/2", 1-pound box, 71 nails	Box	5.82	4.81
16 penny, 3-1/2", 5-pound box, 355 nails	Box	20.30	16.60
16 penny, 3-1/2", 30-pound box, 2,130 nails	Box	74.50	67.60
20 penny, 4", 1-pound box, 62 nails	Box	5.86	4.82
20 penny, 4", 5-pound box, 310 nails	Box	20.50	—

	Unit	Screw shank	Ring shank
Deck nails For use with ACQ or CA pressure-treated lumber. Cost per box.			
6 penny, 2", 1-pound box	Box	6.01	6.20
6 penny, 2", 5-pound box	Box	20.90	21.60
8 penny, 2-1/2", 1-pound box	Box	6.07	6.20
8 penny, 2-1/2", 5-pound box	Box	21.10	20.90
10 penny, 3", 1-pound box	Box	6.03	6.20
12 penny, 3-1/4", 1-pound box	Box	6.03	6.20
12 penny, 3-1/4", 5-pound box	Box	21.30	20.50
16 penny, 3-1/2", 1-pound box	Box	6.07	6.20
16 penny, 3-1/2", 5-pound box	Box	21.10	21.60

	Craft@Hrs	Unit	Material	Labor	Total
Vinyl/cement-coated sinkers Vinyl coating lubricates the wood and holds fast when driven. Head sinks flush with surface.					
4 penny, 1-3/8", 1-pound box, 550 nails	—	Box	3.65	—	3.65
6 penny, 1-7/8", 1-pound box, 275 nails	—	Box	3.88	—	3.88
6 penny, 1-7/8", 5-pound box, 1,375 nails	—	Box	13.60	—	13.60
8 penny, 2-3/8", 1-pound box, 142 nails,	—	Box	3.88	—	3.88
8 penny, 2-3/8", 5-pound box, 710 nails	—	Box	13.60	—	13.60
8 penny, 2-3/8", 50-pound box, 7,100 nails	—	Box	60.30	—	60.30
10 penny, 2-7/8", 5-pound box, 104 nails	—	Box	13.70	—	13.70
12 penny, 3-1/8", 1-pound box, 77 nails	—	Box	3.88	—	3.88
12 penny, 3-1/8", 5-pound box, 385 nails	—	Box	13.60	—	13.60
12 penny, 3-1/8", 50-pound box, 3,850 nails	—	Box	59.20	—	59.20
16 penny, 3-3/8", 1-pound box, 61 nails	—	Box	3.88	—	3.88
16 penny, 3-3/8", 5-pound box, 305 nails	—	Box	13.60	—	13.60
16 penny, 3-3/8", 25-pound box, 1,525 nails	—	Box	40.50	—	40.50
16 penny, 3-3/8", 50-pound box, 3,050 nails	—	Box	60.20	—	60.20

Nails

	Craft@Hrs	Unit	Material	Labor	Total
Plain shank stick collated framing nails					
2" x 0.113", coated, box of 2,000	—	Box	41.50	—	41.50
2-1/2" x 0.120", coated, box of 2,000	—	Box	45.90	—	45.90
2-1/2" x 0.120", galvanized, box of 2,000	—	Box	74.40	—	74.40
3" x 0.120", coated, box of 2,000	—	Box	38.80	—	38.80
3" x 0.120", galvanized, box of 2,000	—	Box	88.20	—	88.20
3-1/4" x 0.120", coated, box of 2,000	—	Box	51.30	—	51.30
3-1/4" x 0.120", galvanized, box of 2,000	—	Box	89.80	—	89.80
3-1/2" x 0.131", coated, box of 2,000	—	Box	61.10	—	61.10
3 1/2" x 0.131", galvanized, box of 2,000	—	Box	85.70	—	85.70
Plain shank coil framing nails, galvanized and coated					
2" x 0.099", box of 3,600	—	Box	104.00	—	104.00
2-1/2" x 0.099", box of 3,600	—	Box	106.00	—	106.00
3" x 0.120", box of 2,700	—	Box	99.80	—	99.80
3-1/4" x 0.120", box of 2,700	—	Box	121.00	—	121.00
Screw shank coil framing nails, plastic coated					
1-5/8" x 0.099", box of 10,800, steel	—	Box	243.00	—	243.00
1-7/8" x 0.099", box of 9,000, aluminum	—	Box	257.00	—	257.00
1-3/4" x 0.086", box of 9,000, steel	—	Box	187.00	—	187.00
2" x 0.099", box of 9,000, steel	—	Box	148.00	—	148.00
2-1/4" x 0.099", box of 7,200, steel	—	Box	122.00	—	122.00
2-1/2" x 0.105", box of 4,000, steel	—	Box	89.60	—	89.60
2-7/8" x 0.105", box of 5,400, steel	—	Box	135.00	—	135.00
Brad nails for an impulse nailer, bright, 18-gauge					
1", box of 1,000	—	Box	5.89	—	5.89
1-1/4", box of 1,000	—	Box	5.59	—	5.59
2", box of 1,000	—	Box	6.78	—	6.78
Casing nails, galvanized. Used where the nail head must be hidden. Casing nails have small, conical heads. The nail diameter is smaller than a common nail but larger than a finishing nail. Casing nails are used to attach trim.					
6 penny, 2", 1-pound box, 236 nails	—	Box	5.86	—	5.86
8 penny, 2-1/2", 1-pound box, 145 nails	—	Box	5.59	—	5.59
10 penny, 3", 1-pound box, 94 nails	—	Box	5.86	—	5.86
16 penny, 3-1/2", 1-pound box, 71 nails	—	Box	5.58	—	5.58
Drywall nails. Allow 6 pounds of nails (1,300 nails) per MSF of gypsum wallboard					
1-1/4", bright, ring shank, 5-pound box	—	Box	16.80	—	16.80
1-3/8", electro galvanized 5-pound box	—	Box	15.90	—	15.90
1-3/8", phosphate coated, 5-pound box	—	Box	17.00	—	17.00
1-3/8", blued, threaded, 5-pound box	—	Box	17.70	—	17.70
1-1/2", blued, threaded, 5-pound box	—	Box	17.70	—	17.70
1-5/8", blued, threaded, 5-pound box	—	Box	15.90	—	15.90
1-7/8", phosphate coated, 5-pound box	—	Box	17.70	—	17.70
Drywall screws. Black phosphate coating. For hanging drywall and plasterboard on wood or metal studs. Allow 1,300 screws per MSF of gypsum wallboard.					
1-1/4", 5-pound box of 1,330	—	Box	26.80	—	26.80
1-5/8", 5-pound box of 1,300	—	Box	26.80	—	26.80
2", 5-pound box of 1,070	—	Box	26.80	—	26.80
2-1/2", 5-pound box of 480	—	Box	26.80	—	26.80
3", 5-pound box of 415	—	Box	26.80	—	26.80



Nails

	Craft@Hrs	Unit	Material	Labor	Total
Finishing nails, bright. Finishing nails have a barrel-shaped head with a small diameter and a dimple on the top. Cost per box.					
3 penny, 1-1/4", 1-pound box, 807 nails	—	Box	4.26	—	4.26
4 penny, 1-1/2", 1-pound box, 584 nails	—	Box	4.26	—	4.26
6 penny, 2", 1-pound box, 309 nails	—	Box	4.26	—	4.26
8 penny, 2-1/2", 1-pound box, 189 nails	—	Box	4.26	—	4.26
16 penny, 3-1/2", 1-pound box, 90 nails	—	Box	4.26	—	4.26
Finishing nail sticks for angled impulse nailer, 16 gauge, bright. Cost per box.					
1", box of 2,000	—	Box	12.20	—	12.20
1-1/4", box of 2,000	—	Box	14.50	—	14.50
1-1/2", box of 2,000	—	Box	17.40	—	17.40
1-3/4", box of 2,000	—	Box	17.80	—	17.80
2", box of 2,000	—	Box	19.50	—	19.50
2-1/2", box of 2,000	—	Box	24.80	—	24.80
Bright joist hanger nails, 9 gauge except as noted. Cost per box.					
1-1/4", 1-pound box	—	Box	5.09	—	5.09
1-1/2", 1-pound box	—	Box	5.09	—	5.09
1-1/2", 1-pound box, 10 gauge	—	Box	5.09	—	5.09
1-1/2", 5-pound box	—	Box	17.70	—	17.70
1-1/2", 5-pound box, 10 gauge	—	Box	17.70	—	17.70
1-1/2", 30-pound box	—	Box	70.50	—	70.50
Galvanized joist hanger nails. 9 gauge. Cost per box.					
1-1/4", 5-pound box	—	Box	21.40	—	21.40
1-1/4", 25-pound box	—	Box	67.90	—	67.90
1-1/2", 1-pound box	—	Box	5.86	—	5.86
1-1/2", 50-pound box	—	Box	93.90	—	93.90
Stainless steel joist hanger nails					
1-1/2", 9 gauge, 1-pound box, 126 nails	—	Box	13.00	—	13.00
1-1/2", 10 gauge, 5-pound box, 735 nails	—	Box	58.60	—	58.60
Masonry nails. Temper hardened, bright.					
1", fluted nail, 1-pound box	—	Box	7.17	—	7.17
1-1/2" fluted nail, 1-pound box	—	Box	7.04	—	7.04
2" fluted nail, 1-pound box	—	Box	7.00	—	7.00
2-1/2" cut nail, flat head, 1-pound box	—	Box	7.00	—	7.00
3", cut nail, flat head, 5-pound box	—	Box	25.80	—	25.80
4-1/2", cut nail, flat head, 1-pound box	—	Box	7.26	—	7.26
Plasterboard nails, 13 gauge, blued					
3/8" head, 1-1/8" (449) or 1-1/4" (405)	—	Lb	5.09	—	5.09
3/8" head, 1-5/8", 342 nails	—	Lb	4.53	—	4.53
Roofing nail coils, for pneumatic nailer					
2 penny, 1", 7,200 nails, galvanized	—	Box	81.40	—	81.40
3 penny, 1-1/4", 7,200 nails, galvanized	—	Box	45.20	—	45.20
5 penny, 2", 3,600 nails, bright	—	Box	64.30	—	64.30
Roofing nails, electro galvanized					
1/2", 1-pound box, 380 nails	—	Box	3.61	—	3.61
3/4", 1-pound box, 315 nails	—	Box	3.36	—	3.36
1-3/4" or 2", 5-pound box, 150 or 138 nails	—	Box	13.50	—	13.50
Roofing nails, galvanized. Ring shank.					
1-1/4", 30-pound box, 6,150 nails	—	Box	75.30	—	75.30
1-1/2", 30-pound box, 5,550 nails	—	Box	80.50	—	80.50
1-3/4", 5-pound box, 800 nails	—	Box	22.10	—	22.10
2-1/2", 50-pound box, 5,900 nails	—	Box	75.90	—	75.90

Nails

	Craft@Hrs	Unit	Material	Labor	Total
Roofing nails, plastic round cap. For securing felt on sandable roof decking or attaching foam board sheathing					
7/8", 11-1/2 gauge, box of 3,000	—	Box	45.70	—	45.70
2" x 0.113", galvanized, box of 5,000	—	Box	109.00	—	109.00
Galvanized roofing staples, wide crown. For shingles and polystyrene sheathing.					
7/8", box of 9,000	—	Box	61.10	—	61.10
1-1/4", box of 9,000	—	Box	79.30	—	79.30
Double head (duplex) nails for use on scaffolds, concrete forms and temporary construction					
6 penny, 2", 1-pound box, 143 nails	—	Box	5.51	—	5.51
6 penny, 2", 5-pound box, 715 nails	—	Box	19.30	—	19.30
8 penny, 2-1/4", 1-pound box, 88 nails	—	Box	5.49	—	5.49
8 penny, 2-1/4", 5-pound box, 440 nails	—	Box	18.70	—	18.70
8 penny, 2-1/4", 30-pound box, 2,640 nails	—	Box	62.30	—	62.30
16 penny, 3-1/4", 1-pound box, 44 nails	—	Box	5.42	—	5.42
16 penny, 3-1/4", 5-pound box, 220 nails,	—	Box	18.70	—	18.70
16 penny, 3-1/4", 30-pound box, 1,320 nails	—	Box	62.30	—	62.30
Siding nails					
1-1/2", aluminum, 1-pound box	—	Box	15.80	—	15.80
2", aluminum, 1-pound box	—	Box	15.20	—	15.20
1-3/4", galvanized, 5-pound box	—	Box	19.60	—	19.60
2-1/4", galvanized, 5-pound box	—	Box	21.30	—	21.30
2-1/2", galvanized, 5-pound box	—	Box	19.20	—	19.20
3", galvanized, 5-pound box	—	Box	18.70	—	18.70
3" double galvanized, 5-pound box	—	Box	23.40	—	23.40
Spikes, galvanized. For landscape timbers, railroad ties, log home construction.					
3/8" x 8", per spike	—	Ea	.62	—	.62
3/8" x 10", per spike	—	Ea	.75	—	.75
3/8" x 10", 5-pound box	—	Box	17.70	—	17.70
3/8" x 12", per spike	—	Ea	.91	—	.91
3/8" x 12", 5-pound box	—	Box	17.70	—	17.70
Powder-driven fastening nails, zinc plated					
3/4", per pack of 20	—	Ea	2.82	—	2.82
7/8", per pack of 20	—	Ea	5.11	—	5.11
1", per pack of 20	—	Ea	8.72	—	8.72
1-1/4", per pack of 20	—	Ea	8.84	—	8.84
1-1/2", per pack of 20	—	Ea	8.19	—	8.19
1-7/8", per pack of 20	—	Ea	9.06	—	9.06
2-1/2", per pack of 20	—	Ea	8.63	—	8.63
3", per pack of 20	—	Ea	9.08	—	9.08
Powder-driven 0.300 pins, with washers					
1-1/2", per pack of 100	—	Ea	17.30	—	17.30
2-1/2", per pack of 100	—	Ea	17.60	—	17.60
3", per pack of 100	—	Ea	19.20	—	19.20

Nuts, Bolts and Washers

	4"	6"	Length 8"	10"	12"
Nuts, Bolts and Washers Bolts, standard hex head, material cost per bolt.					
Heavy duty lag bolts, galvanized, deduct 25% for carton quantities					
1/2"	.70	1.00	1.37	1.84	2.30
5/8"	1.75	2.56	3.34	4.07	4.49
3/4"	2.52	3.32	3.95	4.89	5.96
Machine bolts (hex bolts), galvanized, deduct 25% for carton quantities					
1/2", 13 threads per inch	.88	1.28	1.68	2.00	2.59
5/8", 11 threads per inch	1.57	2.26	2.95	3.69	3.88
3/4", 10 threads per inch	2.22	2.96	3.68	4.60	5.56
7/8", 9 threads per inch	4.95	6.24	8.03	9.92	10.80
1", 8 threads per inch	6.17	8.50	10.50	12.80	14.70
Carriage bolts (domed top and a square under the head), galvanized, deduct 25% for carton quantities					
1/2", 13 threads per inch	.63	.81	1.22	1.37	1.79
5/8", 11 threads per inch	1.07	1.62	2.05	2.45	2.78
3/4", 10 threads per inch	1.83	2.42	3.07	3.67	4.08
	Craft@Hrs	Unit	Material	Labor	Total
Labor to install machine bolts or lag bolts. Includes installation of nuts and washers and drilling as needed.					
4" to 6" long		BC@.100	Ea	—	3.77
8" to 10" long		BC@.150	Ea	—	5.65
12" long		BC@.200	Ea	—	7.53
Nuts, standard hex, galvanized					
1/2"		—	Ea	.19	—
5/8"		—	Ea	.29	—
3/4"		—	Ea	.40	—
7/8"		—	Ea	.81	—
1"		—	Ea	1.09	—
Washers, standard cut steel, galvanized AKA Lock Washers					
1/2"		—	Ea	.16	—
5/8"		—	Ea	.26	—
3/4"		—	Ea	.43	—
7/8"		—	Ea	.69	—
1"		—	Ea	1.06	—
Washers, USS Flat steel, galvanized					
1/2"		—	Ea	.20	—
5/8"		—	Ea	.35	—
3/4"		—	Ea	.48	—
7/8"		—	Ea	.66	—
1"		—	Ea	.79	—
Dock washers, larger OD than flat washers, galvanized, OD typically 3"					
1/2"		—	Ea	2.32	—
5/8"		—	Ea	2.37	—
3/4"		—	Ea	2.49	—
1"		—	Ea	3.15	—

Paint Removal

Craft@Hrs Unit Material Labor Equipment Total

Paint Removal Dustless removal of lead-based paints. The removal system is a mechanical process and no water, chemicals or abrasive grit are used. Containment or special ventilation is not required. Based on Pentek Inc. Costs shown are for a 5,000 SF or larger job. For estimating purposes figure one 55-gallon drum of contaminated waste per 2,500 square feet of coatings removed from surfaces with an average coating thickness of 12 mils. Waste disposal costs are not included. Use \$5,000 as a minimum charge for work of this type. On pre-1978 homes, child care facilities and schools, rules adopted by the Environmental Protection Agency require that: (1) a trained supervisor be on site during paint removal, (2) those affected be given a copy of the EPA pamphlet on lead paint removal, (3) records be retained for three years and (4) steps be taken to prevent the spread of dust and debris. For more information, see <http://www.epa.gov/lead/renovation-repair-and-painting-program>.

Removing paint from ceilings, doors, door and window frames, roofs, siding Equipment includes three pneumatic needle scaler units attached to one air-powered vacuum-waste packing unit and one 150 CFM gas or diesel powered air compressor including all hoses and connectors. Add the one-time charge listed below for move-on, move-off and refurbishing of equipment.

Ceilings

Plaster, 70 SF per hour	PT@.042	SF	—	1.62	1.45	3.07
-------------------------	---------	----	---	------	------	------

Doors, wood or metal. Remove and re-hang doors, no carpentry included

To 3'0" x 6'8"	PT@1.00	Ea	—	38.60	—	38.60
----------------	---------	----	---	-------	---	-------

Over 3'0" x 6'8" to 6'0" x 8'0"	PT@1.50	Ea	—	57.90	—	57.90
---------------------------------	---------	----	---	-------	---	-------

Over 6'0" x 8'0" to 12'0" x 20'0"	PT@2.00	Ea	—	77.10	—	77.10
-----------------------------------	---------	----	---	-------	---	-------

Paint removal (assumes doors are laid flat on saw horses)

80 SF per hour	PT@.038	SF	—	1.47	1.31	2.78
----------------	---------	----	---	------	------	------

Door or window frames

To 3'0" x 6'8"	PT@1.50	Ea	—	57.90	51.801	109.70
----------------	---------	----	---	-------	--------	--------

Over 3'0" x 6'8" to 6'0" x 8'0"	PT@2.00	Ea	—	77.10	69.00	146.10
---------------------------------	---------	----	---	-------	-------	--------

Over 6'0" x 8'0" to 12'0" x 20'0"	PT@3.00	Ea	—	116.00	104.00	220.00
-----------------------------------	---------	----	---	--------	--------	--------

Lintels

Per SF of surface area	PT@.033	SF	—	1.27	1.14	2.41
------------------------	---------	----	---	------	------	------

Roofs

Metal roofs to 3 in 12 pitch

75 SF of surface per hour	PT@.040	SF	—	1.54	1.38	2.92
---------------------------	---------	----	---	------	------	------

Metal roofs over 3 in 12 pitch

65 SF of surface per hour	PT@.046	SF	—	1.77	1.59	3.36
---------------------------	---------	----	---	------	------	------

Wood roofs to 3 in 12 pitch

80 SF of surface per hour	PT@.038	SF	—	1.47	1.31	2.78
---------------------------	---------	----	---	------	------	------

Wood roofs over 3 in 12 pitch

70 SF of surface per hour	PT@.042	SF	—	1.62	1.45	3.07
---------------------------	---------	----	---	------	------	------

Siding

Metal siding, 80 SF per hour	PT@.038	SF	—	1.47	1.31	2.78
------------------------------	---------	----	---	------	------	------

Wood siding, 85 SF per hour	PT@.035	SF	—	1.35	1.21	2.56
-----------------------------	---------	----	---	------	------	------

Walls measured on one face of wall

Concrete, 80 SF per hour	PT@.038	SF	—	1.47	1.31	2.78
--------------------------	---------	----	---	------	------	------

Concrete block, 70 SF per hour	PT@.042	SF	—	1.62	1.45	3.07
--------------------------------	---------	----	---	------	------	------

Plaster, 85 SF per hour	PT@.035	SF	—	1.35	1.21	2.56
-------------------------	---------	----	---	------	------	------

Add for mobilization and demobilization, per job

Move-on & off and refurbish	—	LS	—	—	—	2,500.00
-----------------------------	---	----	---	---	---	----------

Paints, Coatings, and Supplies

	Craft@Hrs	Unit	Material	Labor	Equipment	Total
Removing paint from concrete floor and slab surfaces. Equipment includes three pneumatic manually-operated wheel-mounted scabblers attached to one air-powered vacuum-waste packing unit to scarify concrete floors and slabs and one 150 CFM gas- or diesel-powered air compressor, including all hoses and connectors. Add the one-time charge listed below for move-on, move-off and refurbishing of equipment.						
Large unobstructed areas; floor slabs, driveways, sidewalks						
90 SF of surface per hour	PT@.033	SF	—	1.27	1.14	2.41
Obstructed areas; narrow aisles, areas around equipment						
60 SF of surface per hour	PT@.050	SF	—	1.93	1.73	3.66
Small areas; around decks						
40 SF of surface per hour	PT@.075	SF	—	2.89	2.59	5.48
Add for mobilization and demobilization, per job						
Move-on and off and refurbish	—	LS	—	—	—	2,500.00

Craft@Hrs Unit Material Labor Total

Paints, Coatings, and Supplies Costs are for good to better quality coatings purchased in single-residence quantities. Add 30% for premium quality paints. Contractor prices may be discounted 10% to 15% on residential job quantities. Painting contractors receive discounts of 20% to 25% on steady volume accounts. Labor costs for painting are listed at the end of this section. For more complete coverage of painting costs, see the *National Painting Cost Estimator* at <https://craftsman-book.com/national-estimator-cloud>.



Primers

Oil-based exterior primer-sealer, universal undercoat for use on wood, hardboard, aluminum and wrought iron. Prevents extractive bleeding.

Quart (100 SF per quart)	—	Qt	10.50	—	10.50
Gallon (400 SF per gallon)	—	Gal	26.70	—	26.70
5 gallon (2,000 SF per 5-gallon)	—	5-Gal	101.00	—	101.00
Acrylic (vinyl acrylic) thermoplastic rust-inhibiting metal primer					
(500 SF per gallon)	—	Gal	66.50	—	66.50
Acrylic latex interior primer and sealer, for drywall, plaster, masonry or wood					
Gallon (300-400 SF per gallon)	—	Gal	12.30	—	12.30
5 gallon (1,500-2,000 SF per 5-gallon)	—	Gal	52.60	—	52.60
Linseed (oil base) exterior/ interior primer					
Quart (75 SF per quart)	—	Gal	10.20	—	10.20
Gallon (300 SF per gallon)	—	Gal	27.80	—	27.80
Red oxide metal primer					
(500 SF per gallon)	—	Gal	75.10	—	75.10
Concrete bonding primer, clear					
(350 to 400 SF per gallon)	—	Gal	23.60	—	23.60
Zinc chromate primer					
Quart (100 SF per quart)	—	Qt	106.00	—	106.00
Gallon (400 SF per gallon)	—	Qt	168.00	—	168.00
KILZ® exterior sealer, primer, stainblocker. Mildew-resistant. Blocks tannin bleed on redwood and cedar.					
Kilz® Original, solvent-based,					
1 gallon (300 SF per gallon)	—	Gal	26.80	—	26.80
Kilz® Original, solvent-based,					
5 gallons (1,500 SF per 5 gallons)	—	5 Gal	91.20	—	91.20
Kilz® Complete, solvent-based, low VOC,					
1 gallon (300 SF per gallon)	—	Gal	20.70	—	20.70
Kilz® odorless,					
1 gallon (300 SF per gallon)	—	Gal	23.90	—	23.90
Kilz® 2, water-based,					
1 gallon (300 SF per gallon)	—	Gal	19.00	—	19.00
Kilz® 2, water-based,					
5 gallons (1,500 SF per 5 gallons)	—	5 Gal	86.10	—	86.10

Paint

	Craft@Hrs	Unit	Material	Labor	Total
Kilz® Premium, water-based, 1 gallon (300 SF per gallon)	—	Gal	23.80	—	23.80
Kilz® Premium, water-based, 5 gallons (1,500 SF per 5 gallons)	—	5 Gal	104.00	—	104.00
Kilz® Ceiling paint & primer, water-based, 5 gallons (1,500 SF per 5 gallons)	—	5 Gal	122.00	—	122.00



House paint

Exterior acrylic latex house paint. Mildew and fade resistant. For wood, masonry, brick, stucco, vinyl and aluminum siding and metal. Typical coverage is 400 square feet per gallon.

Flat, gallon	—	Gal	38.60	—	38.60
Flat, 5 gallons	—	5 Gal	158.00	—	158.00
Satin, gallon	—	Gal	45.20	—	45.20
Satin, 5 gallons	—	5 Gal	202.00	—	202.00
Semi-gloss, gallon	—	Gal	44.40	—	44.40
Semi-gloss, 5 gallons	—	5 Gal	201.00	—	201.00
Interior acrylic latex house paint. Typical coverage is 400 square feet per gallon.					
Flat base, gallon	—	Gal	30.60	—	30.60
Flat base, 5 gallons	—	5 Gal	130.00	—	130.00
Flat white, gallon	—	Gal	21.90	—	21.90
Flat white, 5 gallons	—	5 Gal	96.60	—	96.60
Eggshell enamel, quart	—	Qt	20.00	—	20.00
Eggshell enamel, gallon	—	Gal	37.30	—	37.30
Eggshell enamel, 5 gallons	—	5 Gal	168.00	—	168.00
Satin enamel, quart	—	Qt	24.00	—	24.00
Satin enamel, gallon	—	Gal	40.00	—	40.00
Satin enamel, 5 gallons	—	5 Gal	159.00	—	159.00
Semi gloss enamel, quart	—	Qt	21.00	—	21.00
Semi gloss enamel, gallon	—	Gal	38.60	—	38.60
Semi gloss enamel, 5 gallons	—	5 Gal	168.00	—	168.00
High gloss enamel, quart	—	Qt	16.00	—	16.00
High gloss enamel, gallon	—	Gal	41.30	—	41.30
Ceiling paint, gallon	—	Gal	33.60	—	33.60
Ceiling paint, 5 gallons	—	5 Gal	134.00	—	134.00
Texture paint, fiber-reinforced, 2 gallons	—	2 Gal	40.80	—	40.80

Stucco, masonry and concrete paint

Masonry and stucco paint. Acrylic latex paint for interior or exterior. Smooth, rough or textured masonry surfaces

Gallon	—	Gal	25.00	—	25.00
5 gallons	—	5 Gal	116.00	—	116.00
Elastomeric waterproofing, gallon	—	Gal	31.10	—	31.10
Elastomeric waterproofing, 5 gallons	—	5 Gal	140.00	—	140.00
Penetrating sealer, gallon	—	Gal	23.30	—	23.30
Penetrating sealer, 5 gallons	—	5 Gal	95.90	—	95.90

Concrete stain. Forms a tough film on properly prepared concrete patios, basements, pool decks, pillars, brick and sidewalks. Natural slate color. 100 percent acrylic.

Gallon	—	Gal	40.50	—	40.50
5 gallons	—	5 Gal	192.00	—	192.00

Gloss porch and floor enamel. 100 percent acrylic. Mildew-resistant. Recoat in 24 to 48 hours. Full cure in 30 days

Gloss, gallon	—	Gal	33.30	—	33.30
Low luster, gallon	—	Gal	32.20	—	32.20
Low luster, 5 gallons	—	5 Gal	141.00	—	141.00

Masonry waterproofer, for concrete, stucco and masonry, white when applied, dries clear

150 SF per gallon	—	Gal	36.00	—	36.00
750 SF per 5 gallons	—	5 Gal	143.00	—	143.00

Paint

	Craft@Hrs	Unit	Material	Labor	Total
Metal coatings					
Clean metal primer. White. For use on bare, lightly rusted or previously painted surfaces. Creates a strong surface for better topcoat adhesion and weather resistance.					
Quart	—	Qt	10.20	—	10.20
Rust-converting metal primer. Non-toxic, USDA and FDA approved. Works on clean or rusty steel, zinc galvanized metal, aluminum, tin and previously painted surfaces					
Quart	—	Qt	10.20	—	10.20
Gallon	—	Gal	37.80	—	37.80
Oil-based enamel. Industrial grade. Prevents rust, resists cracking, peeling, chipping, and fading. Scuff-, abrasion- and moisture-resistant. Lead-free. Not low volatile organic compound compliant.					
Quart	—	Qt	9.64	—	9.64
Gallon	—	Gal	44.50	—	44.50
Wood finishes					
Exterior opaque stain. For wood siding, decks and fences. Water repellent and mildew-resistant. Gallon covers 400 square feet.					
Acrylic latex, tint or white, gallon	—	Gal	37.30	—	37.30
Acrylic latex, tint or white, 5 gallons	—	5 Gal	169.00	—	169.00
Oil and latex, accent tint, gallon	—	Gal	34.30	—	34.30
Oil and latex, accent tint, 5 gallons	—	5 Gal	145.00	—	145.00
Exterior semi-opaque stain. For wood siding, decks and fences. Water repellent and mildew-resistant. Gallon covers 400 square feet.					
Oil-based stain, gallon	—	Gal	37.10	—	37.10
Oil-based stain, 5 gallons	—	5 Gal	152.00	—	152.00
Water-based stain, gallon	—	Gal	38.60	—	38.60
Water-based stain, 5 gallons	—	5 Gal	181.00	—	181.00
Exterior clear wood finish. For exterior wood doors, windows, furniture and trim. Gallon covers 300 to 400 square feet.					
Tung oil spar varnish, pint	—	Pt	11.80	—	11.80
Tung oil spar varnish, quart	—	Qt	21.90	—	21.90
Marine varnish, gloss or satin, quart	—	Qt	25.70	—	25.70
Urethane clear finish, gloss or satin, quart	—	Qt	17.10	—	17.10
Urethane clear finish, gloss or satin, gallon	—	Gal	48.80	—	48.80
Varathane® gloss, semi or satin, quart	—	Qt	16.10	—	16.10
Varathane® gloss, semi or satin, gallon	—	Gal	55.80	—	55.80
Waterproofing wood finish. For wood siding, decks and fences. Water repellent and mildew resistant. Clear or tinted. Gallon covers 300 to 400 square feet.					
Premium wood weatherproofing, gallon	—	Gal	27.90	—	27.90
Premium wood weatherproofing, 5 gallons	—	5 Gal	120.00	—	120.00
UV-resistant wood finish, gallon	—	Gal	21.40	—	21.40
UV-resistant wood finish, 5 gallons	—	5 Gal	95.60	—	95.60
Penetrating wood finish, gallon	—	Gal	35.40	—	35.40
Penetrating wood finish, 5 gallons	—	5 Gal	160.00	—	160.00
Log home gloss finish, clear or tint, gallon	—	Gal	38.30	—	38.30
Wood water sealer. Clear. Helps maintain wood's natural color. Protects against damage from water and sun. Provides a mildew-resistant coating. Gallon covers 225 to 325 square feet of smooth wood or as little as 125 square feet for a first application on rough-sawn wood.					
Thompson's WaterSeal, gallon	—	Gal	12.90	—	12.90
Thompson's WaterSeal, 5 gallons	—	5 Gal	60.10	—	60.10
Waterproofing wood protector, gallon	—	Gal	22.20	—	22.20
Waterproofing wood protector, 5 gallons	—	5 Gal	108.00	—	108.00

Paint Specialties

	Craft@Hrs	Unit	Material	Labor	Total
Wood preservative. Helps maintain wood's natural color. Protects against wood rot, warping, swelling, termite damage, mildew and moisture. Gallon covers 100 to 300 square feet when applied by brush or roller.					
Seasonite® new wood treatment, liter	—	Liter	20.00	—	20.00
Seasonite® new wood treatment, 2.5 liter	—	2.5 Ltr	42.50	—	42.50
Below ground wood preservative, quart	—	Qt	17.00	—	17.00
Below ground wood preservative, gallon	—	Gal	20.30	—	20.30
Below ground wood preservative, 5 gallon	—	5 Gal	91.20	—	91.20
Copper-Green® preservative, 13.5 ounces	—	Can	12.80	—	12.80
Copper-Green® preservative, gallon	—	Gal	25.80	—	25.80
Interior oil stain. Penetrates into unfinished or stripped wood to highlight and seal the grain.					
Tinted wiping stain, half pint	—	Ea	6.42	—	6.42
Tinted wiping stain, quart	—	Qt	7.50	—	7.50
Tinted wiping stain, gallon	—	Gal	30.00	—	30.00
Danish oil, pint	—	Pt	10.10	—	10.10
Danish oil, quart	—	Qt	12.70	—	12.70
Danish oil, gallon	—	Gal	35.90	—	35.90
Gel stain, quart	—	Qt	18.30	—	18.30
Interior water-based stain. Fast-drying and easy clean-up.					
White wash pickling stain, quart	—	Qt	35.40	—	35.40
White wash pickling stain, gallon	—	Gal	64.40	—	64.40
Tinting stain, half-pint	—	Ea	8.36	—	8.36
Tinting stain, quart	—	Qt	15.00	—	15.00
Paint specialties					
Asphalt-fiber roof and foundation coating, 75 SF per gallon on roof or concrete.					
Solvent type, 900 SF per 4 gallons	—	4 Gal	32.80	—	32.80
Driveway coating					
Acrylic driveway revitalizer (500-700 SF per 4 Gal)	—	4 Gal	44.60	—	44.60
Latex block filler					
(1,000 SF per 5 Gal)	—	5 Gal	124.00	—	124.00
Traffic paint, acrylic, 450 SF per gallon					
Blue, white, yellow or red, 1 gallon	—	Gal	26.30	—	26.30
Blue, white, yellow or red, 5 gallon	—	5 Gal	91.50	—	91.50
Swimming pool enamel					
Insul-X, rubber-based pool paint (350 SF per Gal)	—	Gal	71.40	—	71.40
Insul-X, acrylic, waterborne pool paint (250 SF per Gal)	—	Gal	52.60	—	52.60
Multi-surface waterproofer. For wood, brick, concrete, stucco and masonry. Can be applied to new pressure-treated wood. Paintable. Allows wood to weather naturally. Goes on milky white, dries clear.					
Aerosol can, 11.5 ounces	—	Can	5.34	—	5.34
Gallon	—	Gal	12.90	—	12.90
5 gallon	—	5 Gal	85.50	—	85.50
Paint and varnish remover, 150 SF per gallon					
Quart	—	Qt	14.70	—	14.70
Gallon	—	Gal	44.90	—	44.90

Painting, Labor

	Craft@Hrs	Unit	Material	Labor	Total
Spackling compound (vinyl-paste)					
Interior, 8-ounce	—	Ea	6.00	—	6.00
Wood filler paste	—	Pint	8.62	—	8.62
Thinners					
Acetone	—	Gal	18.90	—	18.90
Industrial thinner	—	Qt	8.56	—	8.56
Denatured alcohol	—	Qt	7.81	—	7.81
Mineral spirits	—	Gal	16.10	—	16.10
Paint thinner	—	Gal	13.50	—	13.50
Shellac or lacquer thinner	—	Gal	20.70	—	20.70
Turpentine	—	Qt	7.85	—	7.85

Painting, Labor Single coat applications except as noted. Not including equipment rental costs. These figures are based on hand work (roller, and brush where required) on residential jobs. Where spray equipment can be used to good advantage, reduce these costs 30% to 40%. Spray painting will increase paint requirements by 30% to 60%. Protection of adjacent materials is included in these costs, but little or no surface preparation is assumed. Per SF of surface area to be painted. Figures in parentheses show how much work should be done in an hour. For more complete coverage of painting costs, see *National Painting Cost Estimator* at <https://craftsman-book.com/national-estimator-cloud>.

Exterior surfaces, per coat, paint grade					
Door and frame, 6 sides (2.5 doors/hour)	PT@.400	Ea	—	15.40	15.40
Siding, smooth, wood (250 SF/hour)	PT@.004	SF	—	.15	.15
Siding, rough or shingle (200 SF/hour)	PT@.005	SF	—	.19	.19
Shutters (50 SF/hour)	PT@.020	SF	—	.77	.77
Stucco (300 SF/hour)	PT@.003	SF	—	.12	.12
Trim, posts, rails (20 LF/hour)	PT@.050	LF	—	1.93	1.93
Windows, including mullions, per SF of opening,					
one side only (67 SF/hour)	PT@.015	SF	—	.58	.58
Add for light sanding (330 SF/hour)	PT@.003	SF	—	.12	.12
Interior surfaces, per coat					
Ceiling, flat latex (250 SF/hour)	PT@.004	SF	—	.15	.15
Ceiling, enamel (200 SF/hour)	PT@.005	SF	—	.19	.19
Walls, flat latex (500 SF/hour)	PT@.002	SF	—	.08	.08
Walls, enamel (400 SF/hour)	PT@.003	SF	—	.12	.12
Baseboard (120 LF/hour)	PT@.008	LF	—	.31	.31
Bookcases, cabinets (90 SF/hour)	PT@.011	SF	—	.42	.42
Floors, wood					
Filling	PT@.007	SF	—	.27	.27
Staining	PT@.006	SF	—	.23	.23
Shellacking	PT@.006	SF	—	.23	.23
Varnishing	PT@.006	SF	—	.23	.23
Waxing, machine	PT@.006	SF	—	.23	.23
Polishing, machine	PT@.008	SF	—	.31	.31
Sanding, hand	PT@.012	SF	—	.46	.46
Sanding, machine	PT@.007	SF	—	.27	.27

Painting, Subcontract

	Craft@Hrs	Unit	Material	Labor	Total
Walls, brick, concrete and masonry					
Oiling and sizing (140 SF/hour)	PT@.007	SF	—	.27	.27
Sealer coat (150 SF/hour)	PT@.007	SF	—	.27	.27
Brick or masonry (165 SF/hour)	PT@.006	SF	—	.23	.23
Concrete (200 SF/hour)	PT@.005	SF	—	.19	.19
Concrete steps, 3 coats (38 SF/hour)	PT@.026	SF	—	1.00	1.00
Window frames and sash, using primer to mask glass and prime sash, topcoats as shown					
1 topcoat (100 SF/hour)	PT@.010	SF	—	.39	.39
2 topcoats (67 SF/hour)	PT@.015	SF	—	.58	.58
Score and peel primer from glass (peels from glass only)					
Per lite	PT@.020	Ea	—	.77	.77

Day Week Month

Paint Spraying Equipment Rental Complete spraying outfit including paint cup, hose, spray gun.

8 CFM electric compressor	109.00	323.00	658.00
44 CFM gas-driven compressor	205.00	522.00	1,120.00
Professional airless, complete outfit	196.00	656.00	1,830.00



Painting, Subcontract, Rule of Thumb Including material, labor, equipment and the subcontractor's overhead and profit.

	Craft@Hrs	Unit	Material	Labor	Total
Typical subcontract costs per square foot of floor area for painting the interior and exterior of residential buildings, including only minimum surface preparation					
Economy, 1 or 2 coats, little brushwork	—	SF	—	—	3.20
Good quality, 2 or 3 coats	—	SF	—	—	7.44

Painting, Subcontract, Cost Breakdown The costs that follow are based on the area of the surface being prepared or painted. Typical subcontract costs, including labor, material, equipment and the subcontractor's overhead and profit.

Surface preparation, subcontract Work performed by hand.

Water blasting (pressure washing), using wheel-mounted portable 2,200 PSI pressure washer					
Light blast (250 SF per hour)	—	SF	—	—	.24
Most work (150 SF per hour)	—	SF	—	—	.38
Rough surface, grime (75 SF per hour)	—	SF	—	—	.73
Light cleaning to remove surface dust and stains					
Concrete or masonry surfaces	—	SF	—	—	.38
Gypsum or plaster surfaces	—	SF	—	—	.38
Wood surfaces	—	SF	—	—	.37
Normal preparation including scraping, patching and puttying					
Concrete or masonry surface					
Painted	—	SF	—	—	.38
Unpainted	—	SF	—	—	.31
Gypsum or plaster surfaces					
Painted	—	SF	—	—	.38
Unpainted	—	SF	—	—	.19
Metal surfaces, light sanding	—	SF	—	—	.18
Wood surfaces, surface preparation, subcontract					
Painted	—	SF	—	—	.37
Unpainted	—	SF	—	—	.18
Puttying	—	LF	—	—	1.66

Painting, Subcontract

	Craft@Hrs	Unit	Material	Labor	Total
Exterior painting, subcontract The estimates below are for hand work (brush and roller). Costs will be 15% to 30% lower when spray equipment can be used to good advantage. These costs include only minimum surface preparation. Add additional surface preparation, if required, from the figures above. Typical subcontract costs.					
Brick or concrete, including acrylic latex masonry primer and latex paint					
1 coat latex	—	SF	—	—	1.00
2 coats latex	—	SF	—	—	1.39
Concrete floors, etch and epoxy enamel	—	SF	—	—	.57
Columns and pilasters, per coat	—	SF	—	—	.81
Cornices, per coat	—	SF	—	—	2.06
Doors, including trim, exterior only					
3 coats	—	Ea	—	—	65.80
2 coats	—	Ea	—	—	47.40
Downspouts and gutters					
Per coat	—	LF	—	—	1.67
Eaves					
No rafters, per coat	—	SF	—	—	.81
With rafters, per coat, brush	—	SF	—	—	1.39
Fences (gross area)					
Plain, 2 coats (per side)	—	SF	—	—	1.93
Plain, 1 coat (per side)	—	SF	—	—	1.15
Picket, 2 coats (per side)	—	SF	—	—	1.79
Picket, 1 coat (per side)	—	SF	—	—	1.03
Lattice work					
1 coat 1 side, gross area	—	SF	—	—	.89
Metal, typical					
1 coat	—	SF	—	—	.72
2 coats	—	SF	—	—	1.25
Porch rail and balusters, per coat					
Gross area	—	SF	—	—	1.76
Handrail only	—	LF	—	—	1.21
Roofs, wood shingle					
1 coat stain plus 1 coat sealer					
Flat roof	—	SF	—	—	.83
4 in 12 pitch	—	SF	—	—	1.07
8 in 12 pitch	—	SF	—	—	1.12
12 in 12 pitch	—	SF	—	—	1.33
1 coat stain plus 2 coats sealer					
Flat roof	—	SF	—	—	1.32
4 in 12 pitch	—	SF	—	—	1.60
8 in 12 pitch	—	SF	—	—	1.72
12 in 12 pitch	—	SF	—	—	1.85
Siding, plain					
Sanding and puttying, typical	—	SF	—	—	.54
Siding and trim, 3 coats	—	SF	—	—	1.68
Siding and trim, 2 coats	—	SF	—	—	1.25
Trim only, 2 coats	—	SF	—	—	1.32
Trim only, 3 coats	—	SF	—	—	1.79
Siding, shingle, including trim					
2 coats oil paint	—	SF	—	—	1.28
1 coat oil paint	—	SF	—	—	.79
2 coats stain	—	SF	—	—	1.21
1 coat stain	—	SF	—	—	.69



Painting, Subcontract

	Craft@Hrs	Unit	Material	Labor	Total
Steel sash					
3 coats (per side)	—	SF	—	—	1.61
Stucco					
1 coat, smooth surface	—	SF	—	—	.81
2 coats, smooth surface	—	SF	—	—	1.22
1 coat, rough surface	—	SF	—	—	.89
2 coats, rough surface	—	SF	—	—	1.46
Window frames and sash, 3 coats					
Per side, one lite	—	Ea	—	—	50.30
Per side, add for each additional lite	—	Ea	—	—	2.81

Interior painting, subcontract The estimates below are for hand work (roller with some brush cut-in). Costs will be 15% to 30% lower when spray equipment can be used to good advantage. These costs include only minimum surface preparation. Add for additional surface preparation, if required, from the preceding pages. Typical subcontract costs.

Cabinets, bookcases, cupboards, per SF of total surface area					
3 coats, paint	—	SF	—	—	4.04
Stain, shellac, varnish or plastic	—	SF	—	—	4.14
Concrete block or brick					
Primer and 1 coat latex	—	SF	—	—	.94
Doors, including trim					
3 coats (per side)	—	SF	—	—	2.48
2 coats (per side)	—	SF	—	—	1.73
Plaster or drywall walls, latex. Add for ceilings from below					
Prime coat or sealer	—	SF	—	—	.51
1 coat smooth surface	—	SF	—	—	.60
1 coat rough surface	—	SF	—	—	.67
1 coat sealer, 1 coat flat					
Smooth surface	—	SF	—	—	.83
Rough surface	—	SF	—	—	1.11
1 coat sealer, 2 coats flat					
Smooth surface	—	SF	—	—	1.12
Rough surface	—	SF	—	—	1.47
1 coat sealer, 2 coats gloss or semi-gloss					
Smooth surface	—	SF	—	—	1.07
Rough surface	—	SF	—	—	1.46
Add for ceilings	—	%	—	—	45.0
Stairs, including risers					
3 coats paint	—	SF	—	—	2.84
Stain, shellac, varnish	—	SF	—	—	2.92
Woodwork, painting					
Priming	—	SF	—	—	.67
2 coats	—	SF	—	—	1.05
2 coats, top workmanship	—	SF	—	—	1.32
3 coats	—	SF	—	—	1.73
3 coats, top workmanship	—	SF	—	—	2.29
Woodwork, staining					
Apply stain	—	SF	—	—	.55
Filling (paste wood filler)	—	SF	—	—	.86
Sanding	—	SF	—	—	.50
Apply wax and polish	—	SF	—	—	.51

Paneling

	Craft@Hrs	Unit	Material	Labor	Total
Paneling See also Hardwood under Lumber and Hardboard.					
Solid plank paneling, unfinished, "V"-joint or T&G, costs include nails and waste.					
Cherry, 3-1/8" wide	BC@.050	SF	3.55	1.88	5.43
Red oak, 3-1/8" wide	BC@.050	SF	7.59	1.88	9.47
Hickory, 3-1/8" wide	BC@.050	SF	6.49	1.88	8.37
Maple, beaded, 3-1/8" wide	BC@.050	SF	6.49	1.88	8.37
Knotty pine, beaded, 3-1/2" wide	BC@.050	SF	2.00	1.88	3.88
Knotty pine, wainscot, 3-1/2" wide	BC@.050	SF	1.41	1.88	3.29
Cape Cod, beaded, 7" wide	BC@.050	SF	2.07	1.88	3.95
Pine, V-edge, 3-1/2" wide	BC@.050	SF	2.00	1.88	3.88
Plywood and hardboard paneling Prefinished 4' x 8' x 1/8" panels with hardboard back. Costs include nails, adhesive and 5% waste.					
Harbor white	BC@.030	SF	1.35	1.13	2.48
Vintage maple	BC@.030	SF	1.32	1.13	2.45
Traditional oak	BC@.030	SF	1.30	1.13	2.43
Honey oak	BC@.030	SF	1.30	1.13	2.43
Cherry oak	BC@.030	SF	1.30	1.13	2.43
Beadboard, v-groove, white	BC@.030	SF	.74	1.13	1.87
Aquatile, water-resistant	BC@.030	SF	.82	1.13	1.95
Aquatile, water-resistant with mosaic insert	BC@.030	SF	.95	1.13	2.08
Hardwood plywood paneling Unfinished 4' x 8' panels. Costs include nails, adhesive and 5% waste					
Birch plywood paneling					
1/8" x 4' x 8'	BC@.032	SF	.91	1.21	2.12
1/4" x 4' x 8'	BC@.032	SF	1.10	1.21	2.31
1/2" x 4' x 8'	BC@.040	SF	1.86	1.51	3.37
3/4" x 4' x 8'	BC@.042	SF	2.29	1.58	3.87
Oak plywood paneling					
1/4" x 4' x 8'	BC@.032	SF	2.28	1.21	3.49
1/2" x 4' x 8'	BC@.040	SF	2.04	1.51	3.55
3/4" x 4' x 8', red oak	BC@.042	SF	2.29	1.58	3.87
Cedar hardwood paneling, natural					
1/4" x 4' x 8'	BC@.032	SF	1.33	1.21	2.54
3/8" x 4' x 8'	BC@.040	SF	1.51	1.51	3.02
1/2" x 4' x 8'	BC@.040	SF	2.41	1.51	3.92
5/8" x 4' x 8'	BC@.042	SF	2.77	1.58	4.35
3/4" x 4' x 8'	BC@.042	SF	3.22	1.58	4.80
Golden Virola paneling					
1/4" x 2' x 2'	BC@.032	SF	1.49	1.21	2.70
1/4" x 2' x 4'	BC@.032	SF	1.49	1.21	2.70
1/4" x 4' x 4'	BC@.032	SF	.98	1.21	2.19
1/4" x 4' x 8'	BC@.032	SF	1.06	1.21	2.27
3/8" x 4' x 8'	BC@.040	SF	1.44	1.51	2.95
1/2" x 2' x 2'	BC@.040	SF	2.26	1.51	3.77
5/8" x 4' x 8'	BC@.042	SF	2.02	1.58	3.60
3/4" x 2' x 2'	BC@.042	SF	3.17	1.58	4.75
Maple paneling					
1/2" x 4' x 8', C-2 grade	BC@.040	SF	2.30	1.51	3.81
3/4" x 4' x 8', B-3 grade	BC@.042	SF	3.82	1.58	5.40
3/4" x 4' x 8', maple/birch	BC@.042	SF	2.39	1.58	3.97



Paving, Subcontract



		Craft@Hrs	Unit	Material	Labor	Total
Vinyl-clad hardboard paneling Vinyl-clad film over hardboard, 4' x 8' x 1/4" panels. Costs include nails, adhesive and 5% waste.						
	White or Aegean Gold	BC@.032	SF	1.58	1.21	2.79
	Blue marble	BC@.032	SF	.60	1.21	1.81
	Harvest pattern	BC@.032	SF	1.22	1.21	2.43
FRP wall and ceiling paneling Fiberglass-reinforced plastic, textured, 0.09" thick, Class C flame spread, 24" x 48" panels. Includes fasteners, adhesive and 5% waste.						
	White or almond	BC@.032	SF	1.12	1.21	2.33
Bamboo tambour paneling 4' x 8' panels. Costs include nails, adhesive and 5% waste.						
	Unfinished natural	BC@.032	SF	4.51	1.21	5.72
	Prefinished natural	BC@.032	SF	5.14	1.21	6.35
	Unfinished amber	BC@.032	SF	4.51	1.21	5.72
	Prefinished amber	BC@.032	SF	5.14	1.21	6.35
	Raw amber	BC@.032	SF	4.51	1.21	5.72
	Raw green	BC@.032	SF	4.51	1.21	5.72
	Raw black	BC@.032	SF	4.51	1.21	5.72
Z-brick paneling Non-ceramic mineral brick-like veneer. Interior or exterior. Coverage per carton is 3-1/2 square feet, 5% added for waste. Include the cost for adhesive from below.						
	Red classic brick, 2-1/4" x 8" x 7/16"	BC@.050	SF	6.50	1.88	8.38
	Inca decorative brick, 2-1/4" x 8" x 7/16"	BC@.050	SF	5.78	1.88	7.66
	Used brick (Inca), 2-1/4" x 8" x 5/16"	BC@.050	SF	5.78	1.88	7.66
	Old Chicago brick, 2-3/8" x 8-1/8" x 5/16"	BC@.050	SF	5.78	1.88	7.66
	Liberty grey brick, 2-1/4" x 8" x 7/16"	BC@.050	SF	6.50	1.88	8.38
	Wheat brick, 2-1/4" x 8" x 7/16"	BC@.050	SF	5.78	1.88	7.66
	Burnt sienna brick, 2-1/4" x 8" x 7/16"	BC@.050	SF	7.23	1.88	9.11
	Mesa beige brick, 2-1/4" x 8" x 7/16"	BC@.050	SF	7.23	1.88	9.11
	Z-Ment mortar adhesive	BC@.012	SF	1.87	.45	2.32
	Z-Ment mortar adhesive, 16 to 20 SF per Gal	—	Gal	33.70	—	33.70
Paving, Subcontract Small areas such as walks and driveways around residential buildings. Typical costs including material, labor, equipment and subcontractor's overhead and profit. No substrate preparation included. Use \$1,800 as a minimum job charge.						
Asphalt paving, including oil seal coat, small or irregular areas (driveways)						
	2" asphalt wear course	—	SF	—	—	3.00
	3" asphalt wear course	—	SF	—	—	3.37
	4" asphalt wear course	—	SF	—	—	4.32
	6" stone base, compacted and graded	—	SF	—	—	1.81
	8" stone base, compacted and graded	—	SF	—	—	2.34
Asphalt seal coats						
	Applied with broom or squeegee	—	SF	—	—	.50
	Fog seal, thin layer of diluted SS1H oil	—	SF	—	—	.22
Seal and sand						
	Thin layer of oil with sand finish	—	SF	—	—	.50
Simco "walk-top"						
or other quick-dry applications						
	Creamy oil	—	SF	—	—	.49
Brick paving						
	On concrete, grouted, laid flat, including concrete base	—	SF	—	—	17.30

Plastering, Subcontract

	Craft@Hrs	Unit	Material	Labor	Total
On concrete, laid solid on edge, 8" x 2-1/4" exposure, no grouting, including concrete base	—	SF	—	—	18.80
On sand bed, laid flat	—	SF	—	—	13.50
On sand bed, 8" x 2-1/4" exposure	—	SF	—	—	15.30
Concrete (including fine grading) paving					
3" concrete, unreinforced	—	SF	—	—	3.83
4" concrete, unreinforced	—	SF	—	—	4.59
4" concrete, mesh reinforcing	—	SF	—	—	4.67
4" concrete, seeded aggregate finish	—	SF	—	—	8.06
Add for colored concrete, most colors	—	SF	—	—	.55
Excavate to 18" below final grade, remove spoil, set edge forms, import Class 2 base, fine grade, set and tie 1/2" rebar 18" o.c. each way, pump 3,250 p.s.i. 6" concrete, score and broom finish concrete	—	SF	—	—	12.20
Porous paving systems Thin-walled HDPE plastic rings connected by an interlocking geogrid structure, installed on a porous base course for residential applications. Rings transfer loads from the surface to the grid structure to an engineered course base. Installed on a prepared base. www.invisiblestructures.com					
Porous paving system with grass filler. Grid rolled out over base course and seeded with grass mixture. Includes fertilizer and soil polymer mix for spreading over base.					
3.3' wide by 33' long rolls	BL@.003	SF	2.99	.09	3.08
Add for 1" sand fill	BL@.001	SF	.10	.03	.13
Porous paving system with gravel fill. Grid rolled out over base course and covered with decorative fill gravel.					
3.3' wide by 33' long rolls	BL@.004	SF	2.91	.12	3.03
Add for 1" gravel fill	BL@.001	SF	.16	.03	.19
Plastering, Subcontract See also Lathing. Typical costs including material, labor, equipment and subcontractor's overhead and profit.					
Acoustical plaster					
Including brown coat, 1-1/4" total thickness	—	SY	—	—	43.20
Plaster on concrete or masonry, with bonding agent					
Gypsum plaster, 1/2" sanded	—	SY	—	—	22.60
Plaster on interior wood frame walls, no lath included					
Gypsum plaster, 7/8", 3 coats	—	SY	—	—	34.00
Keene's cement finish, 3 coats	—	SY	—	—	35.20
Cement plaster finish, 3 coats	—	SY	—	—	37.00
Gypsum plaster, 2 coats, tract work	—	SY	—	—	29.10
Add for ceiling work	—	%	—	—	15.0
Plaster for tile					
Scratch coat	—	SY	—	—	16.50
Brown coat and scratch coat	—	SY	—	—	25.00
Exterior plaster (stucco)					
Walls, 3 coats, 7/8", no lath included					
Textured finish	—	SY	—	—	23.10
Float finish	—	SY	—	—	27.30
Dash finish	—	SY	—	—	30.40
Add for soffits	—	%	—	—	15.0
Portland cement plaster, including metal lath, exterior, 3 coats, 7/8" on wood frame					
Walls	—	SY	—	—	36.80
Soffits	—	SY	—	—	42.40
Deduct for paper back lath	—	SY	—	—	-.15



Plumbing Fixtures and Equipment

Craft@Hrs Unit Material Labor Total

Plumbing Fixtures and Equipment Costs are for good to better quality fixtures and trim installed with the accessories listed. All vitreous china, enameled steel, cast iron, and fiberglass fixtures are white except as noted. Colored acrylic fiberglass fixtures will cost about 6% more. Colored enameled steel, cast iron, or vitreous fixtures will cost about 25% more. No rough plumbing included. Rough plumbing is the drain, waste and vent (DWV) piping and water supply piping that isn't exposed when construction is complete. See costs for rough plumbing at the end of this section. Minimum quality fixtures and trim will cost 10% to 20% less. Deluxe fixtures will cost much more. Installation times assume standard quality work and uncomplicated layouts. For expanded coverage of plumbing cost estimates, see the *National Plumbing & HVAC Estimator* at <https://craftsman-book.com/national-estimator-cloud>.

Bathtubs

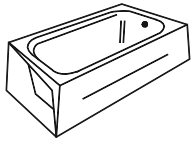

Acrylic fiberglass one-piece bathtub and shower, 5' L, 32" W, 72" H. Includes \$320 allowance for polished chrome pop-up drain/overflow. Mixing valve, tub filler, and 2.5 GPM shower head

Acrylic tub, shower and trim	P1@4.50	Ea	586.00	167.00	753.00
------------------------------	---------	----	--------	--------	--------

Enameled cast iron bathtub, 5' L, 32" W, 15" H for recessed installation. Includes \$320 allowance for polished chrome

pop-up drain/overflow, mixing valve, tub filler and 2.5 GPM shower head

Cast iron tub and trim	P1@3.50	Ea	773.00	130.00	903.00
------------------------	---------	----	--------	--------	--------

Enameled steel bathtub, 5' L, 30" W, 15" H for recessed installations. With full wall flange, and \$320 allowance for pop-up drain/overflow, chrome mixing valve, tub filler, shower flange and 2.5 GPM shower head

Enameled steel tub and trim	P1@1.40	Ea	550.00	52.10	602.10
-----------------------------	---------	----	--------	-------	--------

Enameled steel bathtub with chrome grab rails, 5' L, 32" W, 16" H. Includes \$320 allowance for polished chrome pop-up drain/overflow, mixing valve, tub filler, and 2.5 GPM shower head

Enameled steel tub with handrail and trim	P1@5.25	Ea	1,000.00	195.00	1,195.00
---	---------	----	----------	--------	----------

Recessed whirlpool bathtub with built-in 1.25 HP 115-volt motor and pump, integral drain. With eight multidirectional and adjustable jets. Acrylic with fiberglass reinforcement. White. Includes \$345 allowance for polished chrome pop-up drain/overflow, mixing valve, tub filler, and 2.5 GPM shower head

Whirlpool tub and trim	P1@5.50	Ea	1,280.00	205.00	1,485.00
------------------------	---------	----	----------	--------	----------

Add for electrical connection	—	Ea	—	—	246.00
-------------------------------	---	----	---	---	--------

Indoor whirlpool tub Acrylic fiberglass drop-in whirlpool bathtub, includes \$440 allowance for chrome pop-up drain/overflow, mixing valve and tub filler, with pump and air actuator switch. Add for the electrical connection and tub-support system

6 jets, 1.25 HP, 60" x 36" x 20"	P1@4.00	Ea	1,920.00	149.00	2,069.00
----------------------------------	---------	----	----------	--------	----------

6 jets, 1.25 HP, 60" x 36" x 20", corner	P1@4.00	Ea	1,720.00	149.00	1,869.00
--	---------	----	----------	--------	----------

8 jets, 2 HP, 72" x 42" x 22"	P1@5.00	Ea	2,450.00	186.00	2,636.00
-------------------------------	---------	----	----------	--------	----------

8 jets, 2 HP, 72" x 42" x 22", corner	P1@5.00	Ea	2,680.00	186.00	2,866.00
---------------------------------------	---------	----	----------	--------	----------

Add for polished brass Roman tub filler	P1@1.50	Ea	325.00	55.80	380.80
---	---------	----	--------	-------	--------

Add for chrome Roman tub hand shower	P1@1.50	Ea	228.00	55.80	283.80
--------------------------------------	---------	----	--------	-------	--------

Add for auxiliary in-line water heater	P1@2.00	Ea	228.00	74.40	302.40
--	---------	----	--------	-------	--------

Add for non-load-bearing tub apron	P1@1.00	Ea	305.00	37.20	342.20
------------------------------------	---------	----	--------	-------	--------

Add for electrical connection	—	Ea	—	—	243.00
-------------------------------	---	----	---	---	--------

Whirlpool tub support system, including 150 pounds per square foot pre-tested bracing joists, galvanized cross members, vertical structural 2" pipe bracing, vertical support plate and tub grout pad.

1,500 pound capacity (60" x 36" x 20")	B1@8.00	Ea	783.00	273.00	1,056.00
--	---------	----	--------	--------	----------

2,500 pound capacity (72" x 42" x 22")	B1@8.00	Ea	946.00	273.00	1,219.00
--	---------	----	--------	--------	----------

Hot tub Whirlpool type, illuminated, corner or central, 24" platform mounted, with water temperature regulating heater, whirlpool re-circulating pump, 2" diameter drain, filter and cleanout, custom plywood frame reinforcement, underfloor joist cross-bracing and joist support bracing, subfloor PEX piping to hot water and cold water lines, with valves, control wiring and ground fault protection. NSF, Underwriters Laboratories, and CSA rating.

56-gallon tub and trim	—	Ea	5,470.00	—	5,470.00
------------------------	---	----	----------	---	----------

85-gallon tub and trim	—	Ea	6,560.00	—	6,560.00
------------------------	---	----	----------	---	----------

110-gallon tub and trim	—	Ea	7,070.00	—	7,070.00
-------------------------	---	----	----------	---	----------



Plumbing Fixtures and Equipment

	Craft@Hrs	Unit	Material	Labor	Total
Prepping and sealing of floor pad	B9@8.00	Ea	—	267.00	267.00
Installation of drain	P1@2.00	Ea	341.00	74.40	415.40
Installation of PEX piping and valves	P1@2.00	Ea	216.00	74.40	290.40
Cutting and assembly of wood frame	B1@16.0	Ea	582.00	546.00	1,128.00
Final electrical connections to circulation pump and submerged tub lighting	CE@4.00	Ea	190.00	244.00	434.00

Walk-in Doored Bathtub, ADA-compliant, aerated hydrotherapy type, step-in with watertight sealing door, reinforced fiberglass, illuminated, corner or stand-alone, floor flush-mounted, with submersible seat, handrails and non-slip integral floor and seat surfaces, handheld flexible shower fixture with switchover valve, water temperature regulating 1,500 watt heater, whirlpool re-circulating pump, 2" diameter drain, filter and cleanout, under-floor joist cross-bracing and joist support vertical bracing, sub-floor PEX piping to hot water and cold water lines, with valves, control wiring and ground fault protection. NSF, Underwriters Laboratories, Americans with Disabilities Act, and CSA ratings.

55" long x 30" wide x 40" high (tub only)	—	Ea	2,000.00	—	2,000.00
Prepping and sealing of floor pad	B9@8.00	Ea	—	267.00	267.00
Installation of drain	P1@2.00	Ea	341.00	74.40	415.40
Installation of PEX piping, pump and valves	P1@2.00	Ea	216.00	74.40	290.40
Mounting of tub, cross-joists, vertical column support bracing, and leveling	B1@16.0	Ea	1,390.00	546.00	1,936.00
Final electrical connections to circulation pump, submerged tub lighting and grounding	CE@4.00	Ea	187.00	244.00	431.00

Acrylic shower stalls

Acrylic fiberglass shower stall, 36" W, 36" D, 72" H, includes mixing valve, shower head and door					
Fiberglass 32" shower stall and trim	P1@4.15	Ea	1,510.00	154.00	1,664.00
Acrylic fiberglass shower stall, 48" W, 35" D, 72" H with integral soap dishes, grab bar and drain, mixing valve, shower head and door					
Fiberglass 48" shower stall and trim	P1@4.65	Ea	1,680.00	173.00	1,853.00
Acrylic fiberglass shower stall, 60" W, 35" D, 72" H with integral soap dishes, grab bar, drain, mixing valve, shower head and door					
Fiberglass 60" shower stall and trim	P1@4.80	Ea	1,630.00	179.00	1,809.00
Roll-in wheelchair stall and trim	P1@5.40	Ea	2,300.00	201.00	2,501.00
Add for shower cap (roof)	P1@.500	Ea	236.00	18.60	254.60

Tile shower stalls, subcontract

Framing, plumbing and hot mop for a tiled corner stall shower. Includes framing for L-access dam under door, corner niche and floor slope to center drain, hang and tape Dens Shield tile backer, connect valve, shower head and drain to existing rough-in piping, hot mop shower floor to 10" height. Subcontract. Add the cost of tile, glass enclosure, valve and shower head.

36" x 36" corner shower stall	—	Ea	—	—	3,540.00
Tile for a corner stall shower. Includes 60 SF of 12" x 24" matte finish wall tile with bull nose edges, 14 SF of floor tile and corner shelf. Stacked joint pattern with 1/8" sealed grout joints. Subcontract					
36" x 36" corner shower stall	—	Ea	—	—	2,840.00
Glass enclosure for a corner stall shower. Hinged door. Frameless 3/8" clear or rain glass. Subcontract					
36" x 36" corner shower stall	—	Ea	—	—	1,480.00
Framing and plumbing for a tiled bathtub/shower. Includes alignment of framing and drain for the tub, frame a built-in wall niche, tub installation, hang and tape Dens Shield tile backer on three walls above the tub, connect valve, shower head and drain to existing rough-in piping, installation of valve, shower head and drain. Includes a 5' porcelain tub. Add the cost of tile, glass enclosure, valve and shower head.					
5' bathtub/shower	—	Ea	—	—	3,000.00
Tile for three walls above a bathtub/shower. Includes 80 SF of 12" x 24" matte finish wall tile with 11' of accent border tile and a wall niche. Stacked joint pattern with 1/8" sealed grout joints.					
5' bathtub/shower	—	Ea	—	—	2,350.00
Glass enclosure for a tiled bathtub/shower. Sliding, by-passing doors. Frameless 1/4" clear or rain glass.					
5' bathtub/shower	—	Ea	—	—	493.00

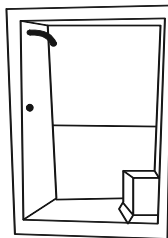
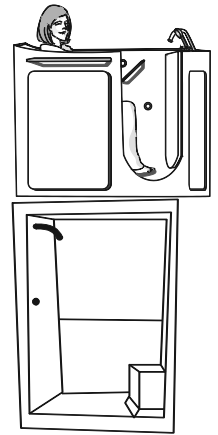

Plumbing Fixtures and Equipment

Craft@Hrs Unit Material Labor Total

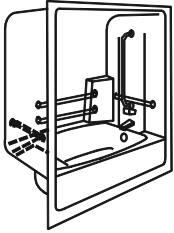

Handicapped tub and shower

Handicapped and elderly access fiberglass tub and shower, 60" x 30" H with integral soap dishes, seat and four grab bars, body washer shower, polished chrome pop-up drain/overflow, mixing valve and tub filler

Handicapped shower-tub and trim	P1@4.75	Ea	6,090.00	177.00	6,267.00
Add for shower curtain rod	P1@.572	Ea	24.90	21.30	46.20

Water closets

Floor-mounted, residential tank type 1.6 gal. vitreous china toilet, valved closet supply, and toilet seat with cover

Floor-mount tank type water closet and trim	P1@2.10	Ea	217.00	78.20	295.20
---	---------	----	--------	-------	--------

Floor-mounted, back outlet, residential tank type 1.6 gal. vitreous china toilet, valved closet supply, elongated bowl, and toilet seat with cover

Floor-mount, back outlet tank type WC and trim	P1@2.35	Ea	346.00	87.50	433.50
--	---------	----	--------	-------	--------

Wall-mounted, tank type 1.6 gal. vitreous china toilet, toilet carrier, valved closet supply, elongated bowl, and toilet seat with cover

Wall-mount, tank type WC, carrier and trim	P1@3.65	Ea	482.00	136.00	618.00
--	---------	----	--------	--------	--------

One piece, 1.6 gal. floor-mounted vitreous china toilet including toilet seat and valved closet supply

One-piece water closet and trim	P1@2.35	Ea	357.00	87.50	444.50
---------------------------------	---------	----	--------	-------	--------

Floor-mounted vitreous china 1.6 gal. pressure assist toilet, including toilet seat and valved closet supply

Pressure assist water closet and trim	P1@2.25	Ea	350.00	83.70	433.70
---------------------------------------	---------	----	--------	-------	--------

Add for elongated bowl models	—	Ea	77.70	—	77.70
-------------------------------	---	----	-------	---	-------

Bidets Standard vitreous china bidet with floor-mounted hardware, hot and cold valved supplies and polished chrome faucet

Vitreous china bidet, vertical spray, and trim	P1@2.50	Ea	456.00	93.10	549.10
--	---------	----	--------	-------	--------

Vitreous china bidet, over the rim, and trim	P1@2.50	Ea	654.00	93.10	747.10
--	---------	----	--------	-------	--------

Lavatories

Oval self-rimming enameled steel lavatory, hot and cold valved supplies, single lever faucet and pop-up drain fitting and trap assembly

Oval self-rim steel lavatory and trim	P1@2.50	Ea	223.00	93.10	316.10
---------------------------------------	---------	----	--------	-------	--------

Oval, self-rimming vitreous china lavatory, hot and cold valved supplies, single lever faucet and pop-up drain fitting and trap assembly

Oval self-rim china lavatory and trim	P1@2.00	Ea	287.00	74.40	361.40
---------------------------------------	---------	----	--------	-------	--------

Oval, pedestal-mounted vitreous china lavatory, hot and cold valved supplies, single lever faucet and pop-up drain fitting and trap

Oval pedestal-mount china lavatory and trim	P1@2.50	Ea	355.00	93.10	448.10
---	---------	----	--------	-------	--------

Rectangular, pedestal-mount vitreous china lavatory, hot and cold valved supplies, single lever faucet and pop-up drain fitting and trap

Rectangular pedestal china lavatory and trim	P1@2.50	Ea	526.00	93.10	619.10
--	---------	----	--------	-------	--------

Rectangular, self-rimming vitreous china lavatory, hot and cold valved supplies, single lever faucet and pop-up drain fitting and trap assembly

Counter-type rectangular china lavatory & trim	P1@2.00	Ea	567.00	74.40	641.40
--	---------	----	--------	-------	--------

Rectangular, wall-hung vitreous china lavatory, hot and cold valved supplies, single lever faucet and pop-up drain fitting and trap assembly

Wall-hung china lavatory and trim	P1@2.50	Ea	290.00	93.10	383.10
-----------------------------------	---------	----	--------	-------	--------

Wheelchair access lavatory, wall-hung vitreous china, with carrier insulated hot and cold valved supplies, gooseneck faucet with wrist handles and pop-up drain and insulated offset trap

Wall-hung wheelchair lavatory and trim	P1@2.75	Ea	290.00	102.00	392.00
--	---------	----	--------	--------	--------

Bar sinks Includes \$130 allowance for chrome faucet, hot and cold water valved supplies and P-trap assembly.

Acrylic bar sink, 15" L, 15" W, 6" D, self-rimming.

Acrylic bar sink and trim	P1@2.00	Ea	281.00	74.40	355.40
---------------------------	---------	----	--------	-------	--------





Enameled cast iron bar sink, 13" L, 15" W, 7" D, undermount

Enameled cast iron bar sink and trim	P1@2.25	Ea	513.00	83.70	596.70
--------------------------------------	---------	----	--------	-------	--------

Stainless steel bar sink, 15" L, 15" W, 5", drop-in

Stainless steel bar sink and trim	P1@2.00	Ea	197.00	74.40	271.40
-----------------------------------	---------	----	--------	-------	--------

Plumbing Fixtures and Equipment

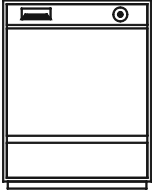
	Craft@Hrs	Unit	Material	Labor	Total	
Kitchen sinks Includes \$184 allowance for chrome faucet and sprayer, P-trap assembly and valved supplies.						
Single bowl, enameled cast iron, self-rimming, 25" L, 22" W, 8" D						
Single bowl cast iron sink and trim	P1@1.75	Ea	401.00	65.10	466.10	
Single bowl, stainless steel, self-rimming sink, 25" L, 22" W, 10" D						
Single bowl stainless sink and trim	P1@2.00	Ea	313.00	74.40	387.40	
Double bowl, enameled cast iron, self-rimming sink, 33" L, 22" W, 8" D						
Double bowl cast iron sink and trim	P1@2.00	Ea	878.00	74.40	952.40	
Double bowl, stainless steel, self-rimming sink, 32" L, 22" W, 8" D						
Double bowl stainless sink and trim	P1@2.25	Ea	297.00	83.70	380.70	
Triple bowl, stainless steel, self-rimming sink, 43" L, 22" W						
Triple bowl stainless sink and trim	P1@2.75	Ea	607.00	102.00	709.00	
Laundry sinks						
Enameled cast iron laundry sink, 48" L, 20" D, 14" D, wall-mounted faucet with integral stops and vacuum breaker, strainer and P-trap assembly						
Cast iron laundry sink and trim	P1@2.76	Ea	2,730.00	103.00	2,833.00	
Acrylic laundry sink, 25" L, 22" D, 12" D, deck-mounted faucet valved supplies, and P-trap assembly						
Acrylic laundry sink and trim	P1@2.00	Ea	475.00	74.40	549.40	
Service sinks						
Enameled cast iron service sink, 22" L, 18" D, wall mounted faucet with integral stops and vacuum breaker, strainer and cast iron P-trap						
Cast iron service sink and trim	P1@3.00	Ea	747.00	112.00	859.00	
Garbage disposers						
Small, 1/3 HP kitchen disposer, including fittings, no waste pipe						
1/3 HP kitchen disposer	P1@2.00	Ea	164.00	74.40	238.40	
Standard, 5/8 HP kitchen disposer, including fittings, no waste pipe						
5/8 HP kitchen disposer	P1@2.00	Ea	264.00	74.40	338.40	
Standard, 3/4 HP kitchen disposer, including fittings, no waste pipe						
3/4 HP kitchen disposer	P1@2.00	Ea	214.00	74.40	288.40	
Septic system, 3/4 HP kitchen disposer, including fittings, no waste pipe						
3/4 HP kitchen disposer	P1@2.00	Ea	323.00	74.40	397.40	
Large capacity, 1 HP kitchen disposer, including fittings, no waste pipe						
1 HP kitchen disposer	P1@2.15	Ea	435.00	80.00	515.00	
Add for electrical connection and switch	BE@1.00	Ea	39.50	41.00	80.50	
Dishwashers Under-counter installation, connected to existing drain. Add the cost of electrical work, if required.						
Deluxe, stainless steel, steam pre wash	P1@2.40	Ea	1,700.00	89.30	1,789.30	
Standard, 5-cycle	P1@2.40	Ea	800.00	89.30	889.30	
Economy, 3 wash levels	P1@2.40	Ea	370.00	89.30	459.30	
Add for electrical connection	BE@1.00	Ea	36.00	41.00	77.00	
Water heaters See also Accessories, water heater for safety pans, earthquake strapping, stands and connections						
Gas water heaters. Includes labor to connect to existing water supply piping and gas line. 6 year warranty. Labor column includes cost of installing heater and making the gas and water connections, but not the cost of the supply lines.						
30 gallon tall, 30,000 BTU, 30.3 GPH	P1@1.90	Ea	539.00	70.70	609.70	
40 gallon short, 34,000 BTU, 36.4 GPH	P1@2.00	Ea	499.00	74.40	573.40	
40 gallon tall, 36,000 BTU, 38.4 GPH	P1@2.00	Ea	479.00	74.40	553.40	
50 gallon tall, 40,000 BTU, 40.4 GPH	P1@2.15	Ea	644.00	79.30	768.30	

Plumbing Fixtures and Equipment

	Craft@Hrs	Unit	Material	Labor	Total
75 gallon tall, 75,100 BTU, 75.8 GPH	P1@3.50	Ea	1,150.00	130.00	1,280.00
40 gallon, 40 MBtu, power vent	P1@2.00	Ea	961.00	74.40	1,035.40
50 gallon, 42 MBtu, power vent	P1@2.15	Ea	1,110.00	80.00	1,190.00
Add for power vent electrical connection	BE@1.00	Ea	37.00	41.00	78.00

Tankless gas water heaters. Includes labor to connect to existing water supply piping and gas line. 6 year warranty. Labor column includes cost of installing the heater and making the gas and water connections but not the cost of the supply lines.

6.4 GPM, 150 MBTU	P1@4.15	Ea	760.00	154.00	914.00
8.4 GPM, 180 MBTU	P1@4.15	Ea	926.00	154.00	1,080.00
9.5 GPM, 200 MBTU	P1@4.15	Ea	1,020.00	154.00	1,174.00
Add for Cat III stainless horizontal vent kit	P1@2.00	Ea	154.00	74.40	228.40
Add for remote temperature control	BE@1.00	Ea	36.30	41.00	77.30
Add for electrical connection	BE@1.00	Ea	44.00	41.00	85.00

Propane water heaters. Includes labor to connect to existing water supply piping. 6 year warranty. Flammable vapor ignition resistant. Labor column includes cost of installing heater and making the water connections, but not the cost of the supply lines.

30 gallon, 30 MBtu	P1@2.00	Ea	749.00	74.40	823.40
40 gallon, 32 MBtu	P1@2.00	Ea	649.00	74.40	723.40
50 gallon, 36 MBtu	P1@2.15	Ea	749.00	80.00	829.00
40 gallon, 40 MBtu, power vent	P1@2.00	Ea	1,150.00	74.40	1,224.40
50 gallon, 36 MBtu, power vent	P1@2.15	Ea	1,200.00	80.00	1,280.00
Add for power vent electrical connection	BE@1.00	Ea	37.00	41.00	78.00

Electric water heaters. Includes labor to connect to existing water supply piping. Add for the cost of supply piping.

30 gallon 30 GPH, 6 year	P1@2.15	Ea	396.00	80.00	476.00
40 gallon 53 GPH, 6 year	P1@2.15	Ea	519.00	80.00	599.00
50 gallon 63 GPH, 6 year	P1@2.25	Ea	449.00	83.70	532.70
50 gallon 55 GPH, 9 year	P1@2.15	Ea	599.00	80.00	679.00
50 gallon 63 GPH, 12 year	P1@2.25	Ea	779.00	83.70	862.70
85 gallon 87 GPH, 12 year	P1@3.50	Ea	1,380.00	130.00	1,510.00
105 gallon 108 GPH, 9 year	P1@3.50	Ea	1,580.00	130.00	1,710.00
40 gallon tall, heat pump technology, 12 year	P1@3.50	Ea	2,240.00	130.00	2,370.00
50 gallon tall, heat pump technology, 12 year	P1@4.00	Ea	2,840.00	149.00	2,989.00

Thermal expansion tank. Controls thermal expansion of water in domestic hot water systems

2 gallon, polypropylene lined steel	P1@.300	Ea	58.80	11.20	70.00
4 gallon, polypropylene lined steel	P1@.300	Ea	87.70	11.10	98.80

Solar water heating system Water storage tanks compatible with most closed-loop solar water heating systems, heat transfer by insulated all-copper heat exchanger, collector feed and return fittings. With pressure-temperature relief valve and back-up 4,500 watt electric heating element. Rheem.

80 gallon	P1@8.44	Ea	2,080.00	314.00	2,394.00
-----------	---------	----	----------	--------	----------

Passive thermosiphon domestic hot water system with integral 80 gallon water tank, retrofitted to an existing single story structure, with 5 year limited warranty

Passive solar water heater system (retrofit)	P1@6.50	Ea	4,300.00	242.00	4,542.00
--	---------	----	----------	--------	----------

Active solar hot water system for 100 or 120 gallon water supply tank, fitted with automatic drain retrofitted to existing single story, single family unit, 5 year warranty

Active solar water heater system (retrofit)	—	Ea	—	—	6,950.00
---	---	----	---	---	----------

Add for strengthening existing roof structure under solar collectors

Per SF of roof strengthened	—	SF	—	—	2.14
-----------------------------	---	----	---	---	------

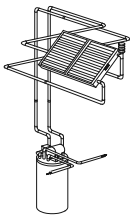

Plumbing Fixtures and Equipment

	Craft@Hrs	Unit	Material	Labor	Total
Active solar hot water system for new one-story home					
Including design and engineering (new work)	—	Ea	—	—	5,670.00
For designs requiring special cosmetic treatment					
Add for concealment of pipe, collectors, etc.	—	%	—	—	15.50
Solar pool heater, active heater for pools with freeze-tolerant collector, roof-mounted					
Per SF of collector area	—	SF	—	—	8.10
Water softening system 24 volt electronic controls, demand-driven regeneration, 5,200 grams per gallon efficiency, 200 pound salt capacity, with bypass valve and drain tubing, 2 hour regeneration time.					
30,400 grain capacity, 95 grams/gallon max hardness removal, 5 grams/gallon max iron reduction, 23 to 30 gallon regeneration	P1@4.00	Ea	397.00	149.00	546.00
40,000 grain capacity, 100 grams/gallon max hardness removal, 7 grams/gallon max iron reduction, 40 to 50 gallon regeneration	P1@4.00	Ea	497.00	149.00	646.00
Water distillation unit Potable central household water system type, Polar Bear 200-L or equal. Underwriters Laboratories and CSA approved, Water Quality Association and certified performance tested to U.S. Environmental Protection Agency Water Quality Act testing standards. Permanent basement mounting, all-electric, 2 parts per million total dissolved solids warranted purity. 220/208/240 volts, 22 amps, 5,300 watts electrical rating. For residential single- and multi-family applications. Includes process condition and flow monitor and 75 gallon tank. Add \$500.00 for optional auto-drain kit.					
50 gal/day distilled water unit	—	Ea	8,040.00	—	8,040.00
Prepping and pouring of pad	P1@2.00	Ea	158.00	74.40	232.40
Mounting of unit	P1@4.00	Ea	—	149.00	149.00
Piping of unit	P1@3.00	Ea	210.00	112.00	322.00
Wiring of controls	CE@4.00	Ea	158.00	244.00	402.00
Piping of vents, pipe and drains	P1@1.00	Ea	158.00	37.20	195.20
Startup and inspection	P1@1.00	Ea	—	37.20	37.20

Plumbing System Components

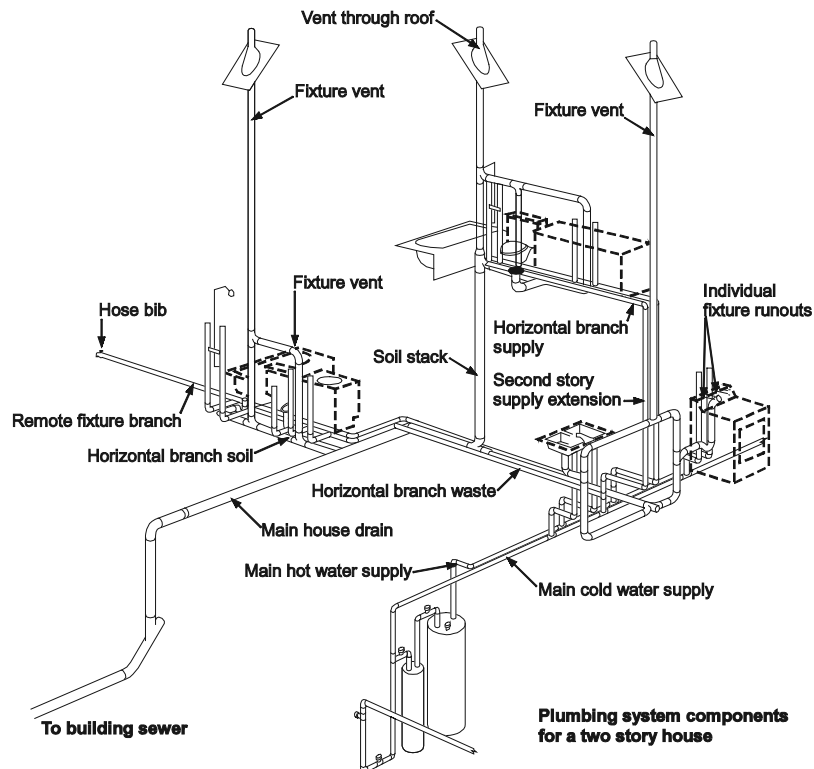

Plumbing, Whole House Rough-In

Craft@Hrs Unit Material Labor Total

Whole House Plumbing Rough-In

Rough plumbing is the drain, waste and vent (DWV) piping and water supply piping that isn't visible when construction is complete. Rough plumbing costs vary with the number of fixtures and length of the pipe runs. The figures in this section show rough plumbing costs for a typical single-family home using plastic drainage and copper water supply materials. No plumbing fixtures, equipment or their final connections are included in these costs. See Plumbing Fixtures and Equipment for fixture and fixture connection costs. These costs include the subcontractor's markup. Add the general contractor's markup when applicable. For more complete information on plumbing and piping costs, see *National Plumbing & HVAC Estimator* at <https://craftsman-book.com/national-estimator-cloud>.

Single story homes

Hot and cold potable water rough-in	P1@15.0	Ea	1,600.00	558.00	2,158.00
Drainage and venting rough-in	P1@20.0	Ea	842.00	744.00	1,586.00
Single story, total plumbing rough-in	P1@35.0	Ea	2,442.00	1,302.00	3,744.00

Two story homes

Hot and cold potable water rough-in	P1@20.0	Ea	2,360.00	744.00	3,104.00
Drainage and venting rough-in	P1@25.0	Ea	1,040.00	931.00	1,971.00
Two story, total plumbing rough-in	P1@45.0	Ea	3,400.00	1,675.00	5,075.00

Plumbing Fixture Rough-In Assemblies Includes labor and material costs for the installation of a typical water supply, drain and vent piping system on new residential construction projects. For renovation projects, add 20% to labor and 10% to material costs to allow for connection to existing service lines and working within existing spaces. Add the cost of any demolition or removal required before the new rough-in can be installed. No plumbing fixtures or fixture connections are included in these costs. See Plumbing Fixtures and Equipment on the following pages for fixture and fixture connection costs. These costs include the subcontractor's markup. Add the general contractor's mark-up.

3-piece washroom group rough-in assembly Includes the water supply, drain and vent piping to connect all three fixtures (tub, toilet and sink) in the group to one common waste, one vent, one hot and one cold water supply line that will be connected to each respective main service drain, vent or supply pipe. These figures are based on the main service piping being within 5' of the fixture group. Add the cost of main water supply, drain and vent lines to which the fixture group will connect.

Hot and cold water supply: 26' of 1/2" type M hard copper pipe (straight lengths), including associated soldered wrought copper fittings, solder, flux, and pipe clips.

Drains and vents: 5' of 3" drainage pipe on the water closet, 38' of 1-1/2" pipe serving all other drains and vents. 43' total plastic drain and vent pipe, with associated fittings, glue and strapping. Make additional allowances for final fixture connections. (See Plumbing Fixtures and Equipment for fixture and connection costs.)

Hot and cold water supply	P1@2.50	Ea	40.40	93.10	133.50
Drains and vents	P1@3.35	Ea	46.80	125.00	171.80
Total washroom group rough-in assembly	P1@5.85	Ea	87.20	218.10	305.30
Add for shower head rough-in	P1@.350	Ea	9.32	13.00	22.32

Kitchen sink rough-in assembly

Hot and cold water supply: 10' of 1/2" type M hard copper pipe, (straight lengths), including associated soldered wrought copper fittings, solder, flux, and pipe clips. Drains and vents: 15' of 1-1/2" plastic drain and vent pipe with associated fittings, glue and strapping. Make additional allowance for final fixture connection. (See Plumbing Fixtures and Equipment for fixture and connection costs.)

Hot and cold water supply	P1@.750	Ea	15.50	27.90	43.40
Drains and vents	P1@1.00	Ea	13.60	37.20	50.80
Total kitchen sink rough-in assembly	P1@1.75	Ea	29.10	65.10	94.20

Plumbing Rough-In Assemblies

Craft@Hrs Unit Material Labor Total

Laundry tub and washing machine rough-in assembly

Hot and cold water supply: 16' of 1/2" type M hard copper pipe (straight lengths), including associated fittings, solder, flux, and pipe clips. Drains and vents: 21' of 1-1/2" plastic drain and vent pipe with associated fittings, glue and strapping.

Hot and cold water supply	P1@1.00	Ea	24.90	37.20	62.10
Drains and vents	P1@1.35	Ea	19.00	50.20	69.20
Total tub & washer rough-in assembly	P1@2.35	Ea	43.90	87.40	131.30

Hot water tank rough-in assembly

Hot and cold water supply: 10' of 3/4" type M hard copper pipe (straight lengths), including associated soldered wrought copper fittings, solder, flux, and pipe clips

Hot and cold water supply	P1@.500	Ea	25.40	18.60	44.00
Add for 3/4" isolation valve	P1@.250	Ea	23.00	9.31	32.31

Water softener rough-in assembly

Hot and cold water supply: 10' of 3/4" type M hard copper pipe (straight lengths), including associated soldered wrought copper fittings, solder, flux, and pipe clips. Regeneration drain: 10' of Schedule 40 PVC, including associated fittings, glue and strapping

Cold water supply and return	P1@.500	Ea	25.40	18.60	44.00
Regeneration drain	P1@.500	Ea	5.58	18.60	24.18

Natural gas appliance rough-in assembly

Includes labor and material to install and test 12' of 3/4" Schedule 40 black steel piping, associated 150 lb malleable iron fittings and a plug valve to serve a typical residential gas fired appliance. Add for the natural gas main supply line running through the building, meter connection and final connection to the appliance. Assembly assumes the appliance is within 5' of the main supply line.

Gas fired domestic hot water heater	P1@.650	Ea	36.20	24.20	60.40
Gas fired hot water heating boiler	P1@.650	Ea	36.20	24.20	60.40
Gas fired forced air furnace	P1@.650	Ea	36.20	24.20	60.40
Gas fired stove and oven	P1@.650	Ea	36.20	24.20	60.40
Gas fired clothes dryer	P1@.650	Ea	36.20	24.20	60.40
Gas main, 1" dia. with fittings and hangers	P1@.120	LF	15.70	4.47	20.17
Gas meter connection (house side only)	P1@.750	Ea	84.10	27.90	112.00

Natural gas appliance connections

Includes labor and material to connect and test a typical residential natural gas fired appliance. Make additional allowances for the natural gas main supply line running through the building, the appliance gas supply rough-in and labor to set the appliance in place.

1/2" FIP x 1/2" MIP coated stainless steel					
12" L	P1@.650	Ea	11.60	24.20	35.80
24" L	P1@.650	Ea	12.60	24.20	36.80
36" L	P1@.650	Ea	14.70	24.20	38.90
48" L	P1@.650	Ea	23.60	24.20	47.80
60" L	P1@.650	Ea	25.80	24.20	50.00
3/4" FIP x 3/4" MIP coated stainless steel					
24" L	P1@.650	Ea	30.20	24.20	54.40
36" L	P1@.650	Ea	20.20	24.20	44.40
48" L	P1@.650	Ea	37.60	24.20	61.80

Plumbing Heating System

Craft@Hrs Unit Material Labor Total

Central hot water heating system

Includes 150' of 1-1/2" insulated supply and return mains, 150' of 3/4" insulated branch piping, 10 radiant baseboard convectors (50'), a 110 Mbh high efficiency gas fired hot water boiler, a circulation pump, electric controls, installed and tested. (Based on 1,200 SF of heated space)

Distribution system	P1@46.0	Ea	1,360.00	1,710.00	3,070.00
Distribution system (second floor)	P1@16.0	Ea	585.00	596.00	1,181.00
Boiler, pump and controls	P1@16.0	Ea	5,770.00	596.00	6,366.00
Radiant baseboard and valves	P1@16.0	Ea	3,520.00	596.00	4,116.00
Radiant baseboard and valves (2nd floor)	P1@12.0	Ea	2,360.00	447.00	2,807.00
Total hot water heating system, 1 story	P1@78.0	Ea	10,650.00	2,902.00	13,552.00
Total hot water heating system, 2 story	P1@106	Ea	13,595.00	3,945.00	17,540.00

Plumbing Access Doors for plumbing, primer coated steel 14 gauge door, 18 gauge frame, with cam lock, for masonry, drywall, tile, wall or ceiling. L&L Louvers

Standard, wall or ceiling

8" x 8"	SW@.500	Ea	18.30	21.30	39.60
12" x 12"	SW@.500	Ea	24.80	21.30	46.10
14" x 14"	SW@.500	Ea	33.20	21.30	54.50
16" x 16"	SW@.500	Ea	35.00	21.30	56.30
18" x 18"	SW@.500	Ea	39.50	21.30	60.80
22" x 22"	SW@.500	Ea	51.10	21.30	72.40
22" x 30"	SW@.500	Ea	63.60	21.30	84.90
24" x 24"	SW@.500	Ea	57.70	21.30	79.00
24" x 36"	SW@.500	Ea	76.30	21.30	97.60
30" x 30"	SW@.500	Ea	104.00	21.30	125.30
Add for cylinder lock	—	Ea	13.70	—	13.70
Add for louvers	—	%	150.0	—	—
Add for fire rating, non-insulated	—	%	400.0	—	—
Add for fire rating and insulated	—	%	500.0	—	—
Add for stainless steel, 304-2B	—	%	400.0	—	—

Polyethylene Film, Clear or Black Material costs include 5% for waste and 10% for laps.

Labor shown is for installation on grade.

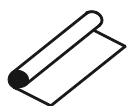

4 mil (.004" thick)					
50 LF rolls, 3' to 20' wide	BL@.002	SF	.08	.06	.14
6 mil (.006" thick)					
50 LF rolls, 3' to 40' wide	BL@.002	SF	.10	.06	.16
Add for installation on walls, ceilings and roofs, tack stapled, typical	BL@.001	SF	—	.03	.03

Railings, Steel, Prefabricated See also Ornamental Iron. Porch or step rail, site fitted.

2'-10" high, 6" OC 1/2" solid twisted pickets, 4' or 6' sections.

1" x 1/2" rails	RI@.171	LF	5.51	6.78	12.29
1" x 1" rails	RI@.180	LF	7.62	7.14	14.76
Add for newel post 3' H with hardware	—	Ea	21.00	—	21.00
Add lamb's tongue for end post	—	Ea	7.64	—	7.64

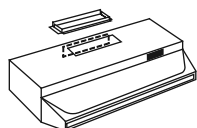

Range Hoods Material costs are for ducted or ductless range hood only, no electrical wiring included.

Add for ducting and electrical connection. Labor costs are for installation of range hood only. No carpentry work included. All models are steel construction with baked enamel finish in various colors.

Economy ducted range hood. Under-cabinet-mounted 190 CFM (cubic feet per minute) exhaust.

6.0 sones. 7" duct connector. 18" deep x 6" high. Washable charcoal filter with replaceable charcoal filter pad. Uses 75-watt lamp. Polymeric lens.

24" or 30" wide, enamel finish	SW@1.42	Ea	96.00	60.40	156.40
24" or 30" wide, stainless steel	SW@1.42	Ea	141.00	60.40	201.40

Range Hoods

	Craft@Hrs	Unit	Material	Labor	Total
36" wide, enamel finish	SW@1.42	Ea	96.00	60.40	156.40
36" wide, stainless steel	SW@1.42	Ea	141.00	60.40	201.40
42" wide, enamel finish	SW@1.42	Ea	99.00	60.40	159.40
42" wide, stainless steel	SW@1.42	Ea	144.00	60.40	204.40
Add for ducted hood with a duct damper	—	Ea	16.00	—	16.00

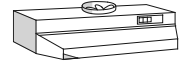

Standard quality ducted range hood. Under-cabinet-mounted 190 CFM (cubic feet per minute) 3-speed blower. 3.5 sones. Either vertical or horizontal 3-1/4" x 10" duct, 7" round duct. Powder-coated 22 gauge steel. 18" deep x 6" high. Uses one 40-watt incandescent lamp.

24" or 30" wide, ducted, black	SW@1.42	Ea	138.00	60.40	198.40
24" or 30" wide, ducted, stainless	SW@1.42	Ea	244.00	60.40	304.40
36" wide, ducted, black	SW@1.42	Ea	153.00	60.40	213.40
36" wide, ducted, stainless	SW@1.42	Ea	223.00	60.40	283.40
42" wide, ducted, black	SW@1.42	Ea	164.00	60.40	224.40
42" wide, ducted, stainless	SW@1.42	Ea	256.00	60.40	316.40
Add for ductless range hood	—	Ea	53.00	—	53.00

Better quality range hood, Allure III NuTone. Under-cabinet-mounted 400 CFM (cubic feet per minute). 0.4 sones at 100 CFM. Teflon-coated bottom pan. Dual halogen lamps. Sensor detects excessive heat and adjusts vent speed. 20" deep x 7-1/4" high. Four ducting options: 3 1/4" x 10" horizontal or vertical vent, 7" round vertical vent or non-ducted.

30" wide, polyester finish	SW@1.42	Ea	518.00	60.40	578.40
30" wide, stainless steel finish	SW@1.42	Ea	565.00	60.40	625.40
36" wide, polyester finish	SW@1.42	Ea	527.00	60.40	587.40
36" wide, stainless steel finish	SW@1.42	Ea	581.00	60.40	641.40
42" wide, polyester finish	SW@1.42	Ea	516.00	60.40	576.40
42" wide, stainless steel finish	SW@1.42	Ea	598.00	60.40	658.40
Add for filter for ducted application	—	Ea	52.00	—	52.00
Add for filter for non-ducted application	—	Ea	27.70	—	27.70

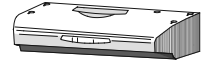

Wall-mount range hood, Ballista NuTone. Stainless steel finish with hood-mounted blower. Three-speed control. Dual 20-watt halogen bulbs. Adjusts to fit under 8' to 10' ceiling. Stainless steel grease filter. Built-in backdraft damper. 20" deep. 33" to 54" high.

30" wide, 450 CFM	SW@2.50	Ea	1,710.00	106.00	1,816.00
36" wide, 450 CFM	SW@2.50	Ea	1,730.00	106.00	1,836.00
48" wide, 900 CFM	SW@2.50	Ea	1,930.00	106.00	2,036.00
Deduct for exterior blower	—	Ea	- 456.00	—	- 456.00

Ceiling-hung range hood, Provisa NuTone. Stainless steel finish with hood-mounted blower. Three-speed control. Four 20-watt halogen bulbs. Telescopic flue adjusts to fit under 8' to 9' ceiling. Stainless steel grease filter. Built-in backdraft damper. 27" deep. 33" high.

40" wide, 900 CFM	SW@3.50	Ea	3,310.00	149.00	3,459.00
Deduct for exterior blower	—	Ea	- 320.00	—	- 320.00

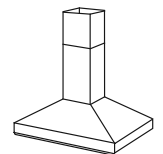

Custom range hood power package. Exhaust system components installed in a custom-built range hood 24" to 30" above the cooking surface. Stainless steel. With variable speed control, filters and halogen or incandescent lighting. Bulbs not included. No ductwork included. Add the cost of a decorative enclosure, ducting and electrical connection.

700 CFM, dual blowers, 7" duct, 1.5 to 4.6 sones

30" wide x 22" deep	SW@1.42	Ea	549.00	60.40	609.40
32" wide x 22" deep	SW@1.42	Ea	597.00	60.40	657.40
36" wide x 28" deep	SW@1.42	Ea	678.00	60.40	738.40
42" wide x 28" deep	SW@1.42	Ea	747.00	60.40	807.40
48" wide x 28" deep	SW@1.42	Ea	845.00	60.40	905.40

Ranges, Built-In

	Craft@Hrs	Unit	Material	Labor	Total
1,300 CFM, dual blowers, twin 7" ducts, 1.5 to 4.6 sones					
30" wide x 22" deep	SW@1.42	Ea	888.00	60.40	948.40
32" wide x 22" deep	SW@1.42	Ea	970.00	60.40	1,030.40
36" wide x 28" deep	SW@1.42	Ea	1,110.00	60.40	1,170.40
42" wide x 28" deep	SW@1.42	Ea	1,210.00	60.40	1,270.40
48" wide x 28" deep	SW@1.42	Ea	1,370.00	60.40	1,430.40
Range splash plate, Broan. Mounts behind range with screws.					
30" x 24", reversible white or almond	SW@.165	Ea	28.40	7.02	35.42
30" x 24", stainless steel	SW@.165	Ea	43.30	7.02	50.32
36" x 24", reversible white or almond	SW@.165	Ea	30.80	7.02	37.82
36" x 24", stainless steel	SW@.165	Ea	49.30	7.02	56.32

Ranges, Built-In Good to better quality counter-mounted cooktops. Labor costs are for carpentry installation only. Add for gas and electric runs and venting. Vented cooktops require exhaust venting. See Range Hoods above.



Gas, pilot-free ignition

Four sealed burners, 30" wide x 21" deep					
Baked enamel top	P1@1.92	Ea	352.00	71.50	423.50
Stainless steel top	P1@1.92	Ea	395.00	71.50	466.50
Five sealed burners, 36" wide x 21" deep					
Stainless steel top	P1@1.92	Ea	766.00	71.50	837.50
Ceramic top	P1@1.92	Ea	1,180.00	71.50	1,251.50

Electric

Conventional coil type cooktop					
Two coils, 21" wide	BE@.903	Ea	382.00	37.10	419.10
Four coils, 30" wide, black	BE@.903	Ea	432.00	37.10	469.10
Four coils, 30" wide, stainless	BE@.903	Ea	560.00	37.10	597.10
Four element smooth glass-ceramic cooktop, 30" wide					
6" and 9" elements	BE@.903	Ea	610.00	37.10	647.10
6"/9"/12" elements	BE@.903	Ea	923.00	37.10	960.10
6" and 12" elements, vented	BE@.903	Ea	1,380.00	37.10	1,417.10
Five element smooth glass-ceramic cooktop, 36" wide					
6"/9"/12" elements	BE@.903	Ea	921.00	37.10	958.10
6"/9"/12" elements, touch controls	BE@.903	Ea	1,420.00	37.10	1,457.10
Five element induction smooth glass-ceramic cooktop, 36" wide					
6"/7"/8"/11" elements, touch controls	BE@.903	Ea	2,050.00	37.10	2,087.10

Ovens, Built-In Material costs are for good to better quality 30" wide built-in self-cleaning ovens with stainless steel exterior and a clear window (except as noted). Labor costs are for setting the oven in a prepared opening and making the electrical connection. Add the cost of electric runs.

Single oven, black on black	BE@1.67	Ea	1,120.00	68.50	1,188.50
Single oven, stainless steel front	BE@1.67	Ea	1,310.00	68.50	1,378.50
Single thermal oven, stainless steel	BE@1.67	Ea	2,130.00	68.50	2,198.50
Double convection/microwave oven	BE@1.67	Ea	2,420.00	68.50	2,488.50
Double convection/thermal oven	BE@1.67	Ea	2,730.00	68.50	2,798.50
Double thermal oven, GE Monogram series	BE@1.67	Ea	4,860.00	68.50	4,928.50
30" warming drawer, stainless steel	BE@1.00	Ea	1,520.00	41.00	1,561.00

Roofing Rule of Thumb Typical subcontract prices per square (100 SF). Based on a 1,500 to 2,000 SF job not over two stories above ground level. Add the cost of flashing and deck preparation, if required. See detailed labor and material costs in the following sections. Many communities restrict use of wood roofing products.

Asphalt shingles (class A, 235 Lb.)	—	Sq	—	—	171.00
Composition shingles (class C, 310 Lb.)	—	Sq	—	—	416.00
Built-up roof, 3-ply and gravel	—	Sq	—	—	270.00

Roofing

	Craft@Hrs	Unit	Material	Labor	Total
Cedar shingles, 16", 5" exposure	—	Sq	—	—	789.00
Split cedar shakes, 24", fire treated	—	Sq	—	—	981.00
Clay mission tile	—	Sq	—	—	383.00
Concrete tile	—	Sq	—	—	422.00

Built-Up Roofing Installed over existing suitable substrate. Add the cost of equipment rental (the kettle) and consumable supplies (mops, brooms, gloves). Typical cost for equipment and consumable supplies is \$15 per 100 square feet applied.

Type 1: 2-ply felt and 1-ply 90-pound cap sheet, including 2 plies of hot mop asphalt

Base sheet, nailed down, per 100 SF	R1@.250	Sq	6.05	9.06	15.11
Hot mop asphalt, 30 lbs. per 100 SF	R1@.350	Sq	17.20	12.70	29.90
Asphalt felt, 15 lbs. per 100 SF	R1@.100	Sq	6.05	3.62	9.67
Hot mop asphalt, 30 lbs. per 100 SF	R1@.350	Sq	17.20	12.70	29.90
Mineral surface 90 lb. cap sheet, per 100 SF	R1@.200	Sq	57.70	7.24	64.94
Type 1, total per 100 SF	R1@1.25	Sq	104.20	45.32	149.52

Type 2: 3-ply asphalt, 1-ply 30 lb felt, 2 plies 15 lb felt, 3 coats hot mop asphalt and gravel

Asphalt felt, 30 lbs. nailed down	R1@.300	Sq	12.10	10.90	23.00
Hot mop asphalt, 30 lbs. per 100 SF	R1@.350	Sq	17.20	12.70	29.90
Asphalt felt, 15 lbs. per 100 SF	R1@.100	Sq	6.05	3.62	9.67
Hot mop asphalt, 30 lbs. per 100 SF	R1@.350	Sq	17.20	12.70	29.90
Asphalt felt, 15 lbs. per 100 SF	R1@.100	Sq	6.05	3.62	9.67
Hot mop asphalt, 30 lbs. per 100 SF	R1@.350	Sq	17.20	12.70	29.90
Gravel, 400 lbs. per 100 SF	R1@.600	Sq	35.00	21.70	56.70
Type 2, total per 100 SF	R1@2.15	Sq	110.80	77.94	188.74

Type 3: 4-ply asphalt, 4 plies 15 lb felt including 4 coats hot mop and gravel

Base sheet, nailed down, per 100 SF	R1@.250	Sq	6.05	9.06	15.11
Hot mop asphalt, 30 lbs. per 100 SF	R1@.350	Sq	17.20	12.70	29.90
Asphalt felt, 15 pound, per 100 SF	R1@.100	Sq	6.05	3.62	9.67
Hot mop asphalt, 30 lbs. per 100 SF	R1@.350	Sq	17.20	12.70	29.90
Asphalt felt, 15 pound, per 100 SF	R1@.100	Sq	6.05	3.62	9.67
Hot mop asphalt, 30 lbs. per 100 SF	R1@.350	Sq	17.20	12.70	29.90
Asphalt felt, 15 lbs. per 100 SF	R1@.100	Sq	6.05	3.62	9.67
Hot mop asphalt, 30 lbs. per 100 SF	R1@.350	Sq	17.20	12.70	29.90
Gravel, 400 lbs. per 100 SF	R1@.600	Sq	35.00	21.70	56.70
Type 3, total per 100 square feet	R1@2.55	Sq	128.00	92.42	220.42

Roof Coatings and Adhesives

Roofing asphalt, 100 lb carton					
145 to 165 degree and Type III (low melt)	—	Ea	52.00	—	52.00
185 degree, certified (high melt) — Type IV	—	Ea	41.90	—	41.90
Asphalt emulsion coating, (35 SF per gallon)					
4.75 gallons	—	Ea	42.40	—	42.40
Wet patch roof cement, Western Colloid #101, (12.5 SF per gallon at 1/8" thick)					
0.9 gallon	—	Ea	21.20	—	21.20
3.3 gallons	—	Ea	52.90	—	52.90
Roof patch elastomeric, seals vertical and horizontal seams (67 SF per gallon)					
0.9 gallon	—	Ea	42.40	—	42.40

Obtaining Roof Area from Plan Area			
Rise	Factor	Rise	Factor
3"	1.031	8"	1.202
3½"	1.042	8½"	1.225
4"	1.054	9"	1.250
4½"	1.068	9½"	1.275
5"	1.083	10"	1.302
5½"	1.100	10½"	1.329
6"	1.118	11"	1.357
6½"	1.137	11½"	1.385
7"	1.158	12"	1.414
7½"	1.179		

When a roof has to be figured from a plan only, and the roof pitch is known, the roof area may be fairly accurately computed from the table above. The horizontal or plan area (including overhangs) should be multiplied by the factor shown in the table opposite the rise, which is given in inches per horizontal foot. The result will be the roof area.



Roof Coatings and Adhesives

	Craft@Hrs	Unit	Material	Labor	Total
Elastomeric white roof coating, non-fibered, white acrylic (100 SF per gallon per coat)					
0.9 gallon	—	Ea	27.30	—	27.30
4.75 gallons	—	Ea	69.80	—	69.80
Fibered aluminum roof coating, non-asbestos fiber, (50 SF per gallon on built-up or smooth surface, 65 SF per gallon on metal surface)					
0.9 gallon	—	Ea	36.90	—	36.90
4.75 gallons	—	Ea	86.10	—	86.10
Silicon roof coating, GacoFlex (50 SF per gallon using two 11 mil coats)					
1 gallon	—	Ea	71.80	—	71.80
5 gallons	—	Ea	244.00	—	244.00
Flashing compound, Western Colloid #106, (12.5 SF per gallon at 1/8" thick)					
0.9 gallon	—	Ea	14.50	—	14.50
2.8 gallons	—	Ea	37.40	—	37.40
4.75 gallons	—	Ea	53.20	—	53.20
Lap cement, Henry #108, (280 LF at 2" lap per gallon)					
0.9 gallon	—	Ea	17.00	—	17.00
4.75 gallons	—	Ea	69.50	—	69.50
Plastic roof cement (12-1/2 SF at 1/8" thick per gallon)					
0.9 gallon	—	Ea	15.90	—	15.90
4.75 gallons	—	Ea	63.10	—	63.10
Non-fibered roof coating, (80 SF per gallon on masonry surfaces or roofing, 100 SF per gallon on metal surfaces)					
0.9 gallon	—	Ea	17.70	—	17.70
4.75 gallons	—	Ea	44.60	—	44.60
Reflective fibered aluminum-flake roof coating (50 SF per gallon on built-up roof or smooth surface, Henry 558 70 SF per gallon on metal surface)					
0.9 gallon	—	Ea	34.30	—	34.30
4.75 gallons	—	Ea	106.00	—	106.00
Wet-dry premium roof cement (12-1/2 SF per gallon at 1/8" thick)					
10.3 oz cartridge for caulking gun	—	Ea	2.97	—	2.97
0.9 gallon	—	Ea	13.50	—	13.50
4.75 gallons	—	Ea	46.90	—	46.90
Cotton mat reinforcing for roof coatings					
6" x 150' roll	—	Ea	25.90	—	25.90
Polyester fabric reinforcing for roof coatings, Henry					
3 oz per SY, 36" x 375'	—	Sq	26.70	—	26.70
Roofing Materials					
Mineral surface roll roofing. Roll covers 1 square (100 square feet).					
90-pound fiberglass mat reinforced	R1@.200	Sq	50.00	7.24	57.24
GAF Mineral Guard	R1@.200	Sq	50.00	7.24	57.24
SBS-modified bitumen, Flintlastic	R1@.200	Sq	77.20	7.24	84.44
Add for mopping in 30-pound hot asphalt	R1@.350	Sq	17.20	12.70	29.90
Roofing felt. Asphalt saturated. Per square. 15-pound roll covers 400 square feet. 30-pound roll covers 200 square feet. Nailed down.					
15-pound, ASTM compliant	R1@.140	Sq	6.05	5.07	11.12
30-pound, ASTM-D226	R1@.150	Sq	12.10	5.43	17.53
Add for mopping in 30-pound hot asphalt	R1@.350	Sq	17.20	12.70	29.90
Fiberglass ply IV roll roofing. ASTM D-2178 Type IV. 500 square foot roll.					
Per 100 square feet	R1@.140	Sq	22.90	5.07	27.97
Add for mopping in 30-pound hot asphalt	R1@.350	Sq	17.20	12.70	29.90

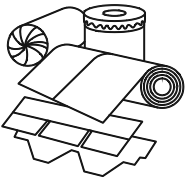

Roofing Shingles

	Craft@Hrs	Unit	Material	Labor	Total
Fiberglass base sheet ASTM D-4601. 300 square foot roll. Nailed down					
Per 100 square feet	R1@.300	Sq	18.20	10.90	29.10
Modified bitumen adhesive. Rubberized. Use to adhere SBS modified bitumen membranes and rolled roofing. Blind nailing cement. Brush grade.					
5 gallons	—	Ea	80.10	—	80.10
Cold process and lap cement. Bonds plies of built-up roofing and gravel to bare spots on existing gravel roof. Restores severely worn roof. Gallon covers 50 square feet.					
0.9 gallon	—	Ea	14.40	—	14.40
4.75 gallons	—	Ea	44.70	—	44.70
Cold-Ap® built-up roofing cement, Henry. Bonds layers of conventional built-up roofing or SBS base and cap sheets. Replaces hot asphalt in built-up roofing. For embedding polyester fabric, gravel and granules. Not recommended for saturated felt. ASTM D3019 Type III. Two gallons cover 100 square feet.					
0.9 gallon	—	Ea	19.20	—	19.20
4.75 gallons	—	Ea	74.90	—	74.90
Cold-process and lap cement. ASTM D3019 Type III. Two gallons cover 100 square feet.					
5 gallons	—	Ea	57.30	—	57.30
Composition Roofing Shingles Material costs include 5% waste. Labor costs include roof loading and typical cutting and fitting for roofs of average complexity. Class A shingles have the highest fire rating.					
3-tab asphalt fiberglass® shingles, Three bundles per square (100 square feet). 5" exposure, Class A fire rating. 60 MPH wind resistance.					
20 year, no algae-resistance	R1@1.83	Sq	61.40	66.30	127.70
25-30 year, algae-resistant	R1@1.83	Sq	87.00	66.30	153.30
Architectural grade laminated shingles, Owens Corning, GAF and similar. Three bundles per square (100 square feet). Class A fire rating. 110 MPH to 130 MPH wind resistance. Limited lifetime warranty.					
No algae resistance	R1@1.83	Sq	114.00	66.30	180.30
Algae resistant, 110mph	R1@1.83	Sq	109.00	66.30	175.30
Algae resistant, 130mph	R1@1.83	Sq	111.00	66.30	177.30
Impact resistant, architectural grade laminated shingles, Class 4, limited lifetime warranty, incl algae-resistance, 130MPH wind resistance, Class A fire. Three bundles per square (100 square feet). Class A fire rating. 110 MPH to 130 MPH wind resistance.					
Class 4 impact rated, lifetime warranty, 130MPH	R1@1.83	Sq	130.00	66.30	196.30
Premium grade laminated shingles, Owens Corning, GAF and similar. Limited lifetime warranty, algae-resistant, Class A fire rating. 110 MPH to 130 MPH wind resistance. Three bundles per square (100 square feet).					
5-inch exposure, 110MPH	R1@1.83	Sq	191.00	66.30	257.30
5-inch exposure, cool roof Title 24, 130MPH	R1@1.83	Sq	216.00	66.30	282.30
Premium, to 8-inch exposure, 130mph	R1@1.83	Sq	312.00	66.30	378.30
Hip and ridge shingles with sealant, Per linear foot of hip or ridge.					
ProEdge hip and ridge	R1@.028	LF	1.83	1.01	2.84
StormMaster hip and ridge	R1@.028	LF	2.06	1.01	3.07
Decorative ridge	R1@.028	LF	2.76	1.01	3.77
Shingle starter strip, Peel 'n' stick SBS membrane. Rubberized to seal around nails and resist wind lift.					
9" x 33' roll	R1@.460	Ea	21.00	16.70	37.70
Per linear foot	R1@.014	LF	.64	.51	1.15
Allowance for felt, flashing, fasteners, and vents.					
Typical cost	—	Sq	25.00	—	25.00

Roofing Papers See also Building Paper. Labor laying paper on 3-in-12 pitch roof.

Asphalt roofing felt (115.5 SF covers 100 SF), labor to roll and mop					
15 lb (432 SF roll)	R1@.490	Sq	6.05	17.70	23.75
30 lb (216 SF roll)	R1@.500	Sq	12.10	18.10	30.20

Roofing Shingles



	Craft@Hrs	Unit	Material	Labor	Total
Glass base sheet (40" x 98' roll covers 300 SF)					
Base for torch applied membranes	R1@.360	Sq	18.20	13.00	31.20
Roofing asphalt, 100 lbs/Sq	—	Sq	52.00	—	52.00
Mineral surfaced roll roofing, 36" x 36' roll covers 100 square feet (1 square)					
90 lb, black or white	R1@1.03	Sq	38.80	37.30	76.10
90 lb, tan	R1@1.03	Sq	47.90	37.30	85.20
Mineral surfaced selvage edge roll roofing, 39.4" x 32.6' roll covers 100 square feet (1 square) with 2" selvage edge overlap					
90 lb, white or colors	R1@1.03	Sq	50.00	37.30	87.30
Roofing Shakes and Shingles					
Red cedar. No pressure treating. Labor includes typical flashing.					
Taper split No. 1 medium cedar shakes, four bundles cover 100 square feet (1 square) at 10" exposure. Includes 10% for waste.					
No. 1 medium shakes	R1@3.52	Sq	409.00	127.00	536.00
Add for pressure treated shakes	—	%	30.0	—	—
Deduct in the Pacific Northwest	—	%	-20.0	—	—
Shake felt, 30 lb	R1@.500	Sq	12.40	18.10	30.50
Hip and ridge shakes, medium, 20 per bundle, covers 16.7 LF at 10" and 20 LF at 12" exposure					
Per bundle	R1@1.00	Ea	77.50	36.20	113.70
Per linear foot, 10" exposure	R1@.060	LF	5.11	2.17	7.28
Per linear foot, 12" exposure	R1@.058	LF	4.26	2.10	6.36
Sawn shakes, sawn 1 side, Class "C" fire retardant					
1/2" to 3/4" x 24" (4 bdle/sq at 10" exp.)	R1@3.52	Sq	483.00	127.00	610.00
3/4" to 5/4" x 24" (5 bdle/sq at 10" exp.)	R1@4.16	Sq	668.00	151.00	819.00
Cedar roofing shingles, No. 1 Grade. Four bundles of Perfection Grade 18" shingles cover 100 square feet (1 square) at 5-1/2" exposure. Five Perfections are 2-1/4" thick. Four bundles of 5X Perfect Grade shingles cover 100 square feet (1 square) at 5" exposure. Five Perfects are 2" thick.					
Perfections	R1@3.52	Sq	386.00	127.00	513.00
Perfects	R1@3.52	Sq	318.00	127.00	445.00
No. 2 Perfections	R1@3.52	Sq	318.00	127.00	445.00
Add for pitch over 6 in 12	—	%	—	40.0	—
No. 2 cedar ridge shingles, medium, bundle covers 16 linear feet					
Per bundle	R1@1.00	Ea	74.10	36.20	110.30
Per linear foot	R1@.062	LF	4.63	2.25	6.88
Fire treated cedar shingles, 18", 5-1/2" exposure, 5 shingles are 2-1/4" thick, (5/2-1/4)					
No. 1 (houses)	R1@3.52	Sq	569.00	127.00	696.00
No. 2, red label (houses or garages)	R1@3.52	Sq	474.00	127.00	601.00
No. 3 (garages)	R1@3.52	Sq	407.00	127.00	534.00
Eastern white cedar shingles, smooth butt edge, four bundles cover 100 square feet (1 square) at 5" exposure					
White extras	R1@3.52	Sq	314.00	127.00	441.00
White clears	R1@3.52	Sq	251.00	127.00	378.00
White No. 2 clears	R1@3.52	Sq	170.00	127.00	297.00
Cedar shim shingles, tapered Western red cedar					
Builder's 12-pack, per pack	—	Ea	6.18	—	6.18

Roofing Sheets

	Craft@Hrs	Unit	Material	Labor	Total
Roofing Sheets See also Fiberglass Panels.					
Metal sheet roofing, utility gauge					
26" wide, 5-V crimp (includes 15% coverage loss)					
6' to 12' lengths	R1@.027	SF	2.03	.98	3.01
26" wide, corrugated (includes 15% coverage loss)					
6' to 12' lengths	R1@.027	SF	1.16	.98	2.14
27-1/2" wide, corrugated (includes 20% coverage loss)					
6' to 12' lengths	R1@.027	SF	1.13	.98	2.11
Ridge roll, plain					
10" wide	R1@.030	LF	3.40	1.09	4.49
Ridge cap, formed, plain, 12"					
12" x 10' roll	R1@.061	LF	1.61	2.21	3.82
Sidewall flashing, plain					
3" x 4" x 10'	R1@.035	LF	1.12	1.27	2.39
V-5 crimp closure strips					
24" long	R1@.035	Ea	1.69	1.27	2.96
Endwall flashing, 2-1/2" corrugated					
10" x 28"	R1@.035	LF	2.34	1.27	3.61
Wood filler strip, corrugated					
7/8" x 7/8" x 6'	R1@.035	LF	.48	1.27	1.75
Steel Panel Roofing Simulated tile, Met-Tile™. 15% waste included.					
Roofing panels, 2' to 20' long					
26 gauge .019" thick	R1@.027	SF	2.26	.98	3.24
End cap					
4-3/4"	R1@.030	Ea	4.42	1.09	5.51
5-3/4" round	R1@.030	Ea	4.42	1.09	5.51
9-1/2" oversized	R1@.030	Ea	5.86	1.09	6.95
Flashing, galvanized steel					
End wall	R1@.047	LF	2.26	1.70	3.96
Plain side wall	R1@.047	LF	2.26	1.70	3.96
Valley cover	R1@.047	LF	2.25	1.70	3.95
Valley pan	R1@.047	LF	2.98	1.70	4.68
Contoured end wall	R1@.047	LF	5.86	1.70	7.56
Ridge-hip-gables					
Spanish 18" x 14-1/2"	R1@.035	Ea	6.35	1.27	7.62
Standard 7-1/2" x 42"	R1@.030	Ea	12.90	1.09	13.99
Trim					
Standard eave trim	R1@.035	LF	1.81	1.27	3.08
Flat edge trim	R1@.035	LF	1.81	1.27	3.08
Shake eave trim	R1@.035	LF	2.35	1.27	3.62
Hood vents					
18" x 22"	R1@.448	Ea	2.35	16.20	18.55
Roofing Slate Local delivery included. Costs will be higher where slate is not mined. Add freight cost at 800 to 1,000 pounds per 100 SF. Includes 20" long random width slate, 3/16" thick, 7-1/2" exposure.					
Meets Standard SS-S-451.					
Semi-weathering green and gray	R1@11.3	Sq	528.00	409.00	937.00
Vermont black and gray black	R1@11.3	Sq	629.00	409.00	1,038.00
China black or gray	R1@11.3	Sq	713.00	409.00	1,122.00
Unfading and variegated purple	R1@11.3	Sq	713.00	409.00	1,122.00
Unfading mottled green and purple	R1@11.3	Sq	713.00	409.00	1,122.00
Unfading green	R1@11.3	Sq	584.00	409.00	993.00
Red slate	R1@13.6	Sq	1,830.00	493.00	2,323.00
Add for other specified widths and lengths	—	%	20.0	—	—

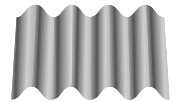

Roofing, Tile

Craft@Hrs Unit Material Labor Total

Fiber Cement Slate Roofing Eternit™, Stonit™, or Thrutone™, various colors. Non-asbestos formulation. Laid over 1/2" sheathing. Includes 30 lb. felt and one copper storm anchor per slate. Add for sheathing, flashing, hip, ridge and valley units.

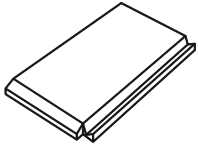

23-5/8" x 11-7/8", English (420 lb, 30 year)					
2" head lap (113 pieces per Sq)	R1@5.50	Sq	580.00	199.00	779.00
3" head lap (119 pieces per Sq)	R1@5.75	Sq	609.00	208.00	817.00
4" head lap (124 pieces per Sq)	R1@6.00	Sq	630.00	217.00	847.00
Add for hip and ridge units, in mastic	R1@0.10	LF	11.80	3.62	15.42
15-3/4" x 10-5/8", Continental (420 lb, 30 year)					
2" head lap (197 pieces per Sq)	R1@6.50	Sq	598.00	235.00	833.00
3" head lap (214 pieces per Sq)	R1@6.75	Sq	652.00	244.00	896.00
4" head lap (231 pieces per Sq)	R1@7.00	Sq	706.00	254.00	960.00
Add for hip and ridge units, in mastic	R1@0.10	LF	10.90	3.62	14.52
Copper storm anchors, box of 1,000 (\$44.00)	—	Ea	.04	—	.04
Stainless steel slate hooks	—	Ea	.47	—	.47
Add for extra felt under 5-in-12 pitch	R1@0.20	Sq	6.05	7.24	13.29

Roofing Tile, Clay Material costs include felt and flashing. No freight or waste included. Costs will be higher where clay tile is not manufactured locally. U.S. Tile Co.

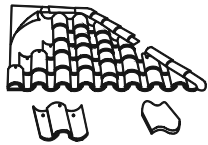

Spanish tile, "S"-shaped, 88 pieces per square, (800 lbs per square at 11" centers and 15" exposure)					
Natural red clay tile	R1@4.50	Sq	330.00	163.00	493.00
Add for coloring ("flashed")	—	Sq	15.30	—	15.30
Red hip and ridge units	R1@.047	LF	1.16	1.70	2.86
Color hip and ridge units	R1@.047	LF	1.65	1.70	3.35
Red rake units	R1@.047	LF	2.21	1.70	3.91
Color rake units	R1@.047	LF	2.43	1.70	4.13
Red clay mission tile 2-piece, 86 pans and 86 tops per square, 7-1/2" x 18" x 8-1/2" tiles at 11" centers and 15" exposure					
Natural red clay tile	R1@5.84	Sq	384.00	212.00	596.00
Add for coloring (costs vary widely)	—	Sq	58.30	—	58.30
Red hip and ridge units	R1@.047	LF	1.22	1.70	2.92
Color hip and ridge units	R1@.047	LF	1.65	1.70	3.35
Red rake units	R1@.047	LF	2.21	1.70	3.91
Color rake units	R1@.047	LF	2.43	1.70	4.13

Concrete Roof Tile Material includes felt, nails and flashing. Approximately 90 pieces per square. Monier Lifetile

Shake, slurry color	R1@4.25	Sq	184.00	154.00	338.00
Slate, thru color	R1@4.25	Sq	224.00	154.00	378.00
Espana, slurry coated	R1@4.25	Sq	224.00	154.00	378.00
Monier 2000	R1@4.25	Sq	237.00	154.00	391.00
Vignette	R1@4.25	Sq	209.00	154.00	363.00
Collage	R1@4.25	Sq	209.00	154.00	363.00
Tapestry	R1@4.25	Sq	228.00	154.00	382.00
Split shake	R1@4.25	Sq	252.00	154.00	406.00
Villa, slurry coat	R1@4.25	Sq	207.00	154.00	361.00
Villa, Roma, thru color	R1@4.25	Sq	213.00	154.00	367.00
Trim tile					
Mansard "V"-ridge or rake, slurry coated	—	Ea	2.93	—	2.93
Mansard, ridge or rake, thru color	—	Ea	3.06	—	3.06
Hipstarters, slurry coated	—	Ea	25.20	—	25.20
Hipstarters, thru color	—	Ea	32.10	—	32.10

Safes

	Craft@Hrs	Unit	Material	Labor	Total
Accessories					
Eave closure or birdstop	R1@.030	LF	1.75	1.09	2.84
Hurricane or wind clips	R1@.030	Ea	.63	1.09	1.72
Underlayment or felt	R1@.050	Sq	12.10	1.81	13.91
Metal flashing and nails	R1@.306	Sq	13.10	11.10	24.20
Pre-formed plastic flashings					
Hip (13" long)	R1@.020	Ea	45.20	.72	45.92
Ridge (39" long)	R1@.030	Ea	46.30	1.09	47.39
Anti-ponding foam	R1@.030	LF	.40	1.09	1.49
Batten extenders	R1@.030	Ea	1.56	1.09	2.65
Roof loading					
Add to load tile and accessories on roof	R1@.822	Sq	—	29.80	29.80

Wall Safes, Residential UL approved combination lock, flush combination dial, 1/2" thick door. Fits between 16" on center studs. Installed during new construction.

For 2 x 4 wall thickness, outside dimensions 13.5" x 14" x 3.75"					
Capacity 400 cu. inches	BC@.788	Ea	629.00	29.70	658.70
For 2 x 6 wall thickness, outside dimensions 13.5" x 14" x 5.75"					
Capacity 750 cu. inches	BC@.788	Ea	658.00	29.70	687.70
For 2 x 12 wall thickness, outside dimensions 13.5" x 14" x 10.25"					
Capacity 1,350 cu. inches	BC@.950	Ea	696.00	35.80	731.80
For 2 x 12 wall thickness, outside dimensions 14" x 14" x 10.25"					
Capacity 1,550 cu. inches	BC@.950	Ea	906.00	35.80	941.80
Optional equipment					
Jewelry interior	—	Ea	78.80	—	78.80
Installation kit	—	Ea	21.00	—	21.00

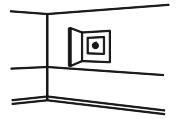

Floor Safes, Residential 1/2" thick spring counter-balanced square door (13" x 13"), UL approved Group Two combination lock, metal cover plate – creates flush floor surface. Installed during new construction.

Outside dimensions 14.5" x 16" x 10.25"					
Capacity 1,100 cu. inches	BC@1.10	Ea	567.00	41.40	608.40
Outside dimensions 14.5" x 16" x 16.25"					
Capacity 2,325 cu. inches	BC@1.25	Ea	672.00	47.10	719.10
Outside dimensions 14.5" x 16" x 21.75"					
Capacity 3,545 cu. inches	BC@1.35	Ea	781.00	50.80	831.80
Outside dimensions 14.5" x 25" x 16.25"					
Capacity 3,970 cu. inches	BC@1.42	Ea	951.00	53.50	1,004.50
Outside dimensions 25" x 25" x 16.75"					
Capacity 7,050 cu. inches	BC@1.55	Ea	1,100.00	58.40	1,158.40
Outside dimensions 14.5" x 48" x 16.25"					
Capacity 7,775 cu. inches	BC@1.60	Ea	1,320.00	60.30	1,380.30
Upgrade to CB-Rating, 1" thick steel door, 1/4" body					
	—	%	15.0	—	—
Optional equipment					
Electronic push button lock	—	Ea	205.00	—	205.00
Dual key lock – in place of combination lock	—	Ea	36.80	—	36.80
Slotted doors (deposit slot)	—	Ea	78.80	—	78.80
Combination change kit	—	Ea	10.50	—	10.50

Sandblasting

Craft@Hrs Unit Material Labor Total

Man Safes, Residential Pry resistant door design, reinforced door jambs, 1" locking bolts, UL approved Group Two combination lock, basic drawer configuration. Installed during new construction.

Outside dimensions 15" x 19" x 17" Capacity 2 cu. feet	BC@1.75	Ea	6,280.00	65.90	6,345.90
Outside dimensions 21" x 19" x 22" Capacity 4 cu. feet	BC@2.00	Ea	6,800.00	75.30	6,875.30
Outside dimensions 41" x 19" x 42" Capacity 7 cu. feet	BC@2.25	Ea	7,850.00	84.70	7,934.70

Sandblasting, Waterblasting, Subcontract The minimum charge for on-site (truck-mounted) sandblasting and waterblasting will usually be about \$500.00. Add the cost of extra liability insurance and physical barriers to protect adjacent swimming pools, residences, process plants, etc. No scaffolding included. Based on sandblasting with 375 CFM, 125 PSI compressor. Portable hydroblast and sandblast equipment for worksites beyond 30 miles from base will incur a \$50 transit time fee. Typical fuel surcharge is \$100 per 8-hour shift.



Sandblasting most surfaces					
Water soluble paints	—	SF	—	—	2.89
Oil paints	—	SF	—	—	3.30
Heavy mastic	—	SF	—	—	3.64
Sandblasting masonry					
Brick	—	SF	—	—	4.25
Block walls, most work	—	SF	—	—	3.17
Remove heavy surface grime	—	SF	—	—	3.82
Heavy, exposing aggregate	—	SF	—	—	4.18
Sandblasting concrete tilt-up panels					
Light blast	—	SF	—	—	3.36
Medium, exposing aggregate	—	SF	—	—	4.28
Heavy, exposing aggregate	—	SF	—	—	4.82
Sandblasting steel					
New, uncoated (commercial grade)	—	SF	—	—	3.76
New, uncoated (near white grade)	—	SF	—	—	4.67
Epoxy coated (near white grade)	—	SF	—	—	5.40
Sandblasting wood					
Medium blast, clean and texture	—	SF	—	—	3.55
Waterblast (hydroblast) with mild detergent					
To 5,000 PSI blast (4 hour minimum)	—	Hr	—	—	422.00
5,000 to 10,000 PSI blast (8 hour min.)	—	Hr	—	—	437.00
Over 10,000 PSI blast (8 hour minimum)	—	Hr	—	—	697.00
Wet sandblasting					
(4 hour minimum)	—	Hr	—	—	587.00

Sauna Rooms Costs listed are for labor and materials to install sauna rooms as described. Units are shipped as a disassembled kit complete with kiln dried softwood paneling boards, sauna heater, temperature and humidity controls and monitors, pre-assembled benches, prehung door, water bucket and dipper, and interior light. No electrical work included.

Western red cedar panel built sauna room package with heater, controls, duckboard floor and accessories. Glass front. Furniture grade interior. Ready for nailing to existing framed and insulated walls with exterior finish. Ceiling height 7'.

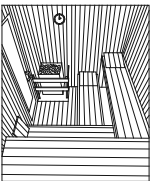

4' x 4' room	B1@6.68	Ea	5,990.00	228.00	6,218.00
4' x 6' room	B1@6.68	Ea	8,100.00	228.00	8,328.00
6' x 6' room	B1@8.00	Ea	8,670.00	273.00	8,943.00
6' x 8' room	B1@8.00	Ea	10,100.00	273.00	10,373.00
8' x 8' room	B1@10.7	Ea	13,400.00	365.00	13,765.00
8' x 10' room	B1@10.7	Ea	14,600.00	365.00	14,965.00
Add for electrical connection wiring	—	LS	—	—	335.00

Screen

	Craft@Hrs	Unit	Material	Labor	Total
Custom-cut 100% vertical grain redwood or clear western red cedar sauna room package with heater, controls and accessories (including non-skid removable rubberized flooring). Ready for nailing to existing framed and insulated walls, exterior 7' ceiling height.					
4' x 4' room	B1@8.00	Ea	4,580.00	273.00	4,853.00
4' x 6' room	B1@8.00	Ea	5,180.00	273.00	5,453.00
5' x 6' room	B1@8.00	Ea	5,470.00	273.00	5,743.00
6' x 6' room	B1@10.0	Ea	5,940.00	341.00	6,281.00
6' x 8' room	B1@12.0	Ea	6,830.00	409.00	7,239.00
8' x 8' room	B1@14.0	Ea	9,470.00	478.00	9,948.00
8' x 10' room	B1@15.0	Ea	10,200.00	512.00	10,712.00
10' x 10' room	B1@16.0	Ea	10,900.00	546.00	11,446.00
10' x 12' room	B1@16.0	Ea	11,800.00	546.00	12,346.00
Add for electrical connection wiring	—	LS	—	—	335.00
			7-foot roll	10-foot roll	25-foot roll
					100-foot roll
Screen Wire Vinyl-coated fiberglass, noncombustible					
Charcoal or gray, cost per roll					
36" wide roll	7.76		—	16.90	49.00
48" wide roll	9.98		—	19.50	60.00
60" wide roll	—		10.80	35.60	133.00
72" wide roll	—		13.00	36.20	136.00
84" wide roll	—		15.10	29.10	205.00
96" wide roll	—		17.30	33.40	131.00
			7-foot roll	25-foot roll	50-foot roll
					100-foot roll
Screen Wire, solar Blocks 90% of the sun's heat and glare. Protect interior surfaces from fading.					
Black, cost per roll					
36" wide roll	17.00		54.90	126.00	244.00
48" wide roll	22.80		68.40	173.00	303.00
60" wide roll	33.50		134.00	233.00	395.00
84" wide roll	—		—	356.00	541.00
			Craft@Hrs	Unit	Material
			Labor	Total	
Labor to install screen wire					
Includes measure, lay out, cut and attach screen wire to an existing metal or wood frame.					
Per linear foot of perimeter of frame	BC@.040	LF	—	1.51	1.51
Security Alarms, Subcontract Costs are for securing building perimeter and all accessible openings with electronic alarm system, including all labor and materials. Costs assume that no interior wall, floor, or ceiling finishes are in place. All equipment is good to better quality.					
Alarm control panel	—	Ea	—	—	557.00
Wiring, detectors per opening, with switch	—	Ea	—	—	96.50
Monthly monitoring charge	—	Mo	—	—	39.60
Alarm options (installed)					
Audio detectors	—	Ea	—	—	139.00
Communicator (central station service)	—	Ea	—	—	310.00
Digital touch pad control	—	Ea	—	—	171.00
Entry/exit delay	—	Ea	—	—	121.00
Fire/smoke detectors	—	Ea	—	—	207.00
Interior/exterior sirens	—	Ea	—	—	92.30
Motion detector	—	Ea	—	—	280.00
Panic button	—	Ea	—	—	68.70
Passive infrared detector	—	Ea	—	—	386.00
Pressure mat	—	LF	—	—	112.00
Security light control	—	Ea	—	—	676.00
Add for wiring detectors and controls in existing buildings					
With wall and ceiling finishes already in place	—	%	—	—	25.0

Security Guards

	Craft@Hrs	Unit	Material	Labor	Total
Security Guards, Subcontract Construction site security guards, unarmed, in uniform with two-way radio, backup patrol car, bond, and liability insurance. Per manhour.					
Short term (1 night to 1 week)	—	Hr	—	—	48.30
Medium duration (1 week to 1 month)	—	Hr	—	—	47.00
Long term (1 to 6 months)	—	Hr	—	—	31.80
Add for licensed armed guard	—	Hr	—	—	7.26
Add for holidays	—	%	—	—	55.0
Construction site guard dog service for sites with totally enclosed perimeter, 24 hour per day, 7 day per week service. Local business codes may restrict or prohibit unattended guard dogs. Includes dog handling training session, liability insurance, on-site kennel. Cost per month.					
Contractor feeding and tending dog	—	Mo	—	—	823.00
Daily delivery of guard dog at quitting time and pickup at starting time by guard dog service (special hours require advance notice)					
Service feeding and tending dog	—	Mo	—	—	861.00
Construction site man and dog guard team, includes two-way radio communication with guard service office, backup patrol car, and liability insurance. Guard service may require that a telephone and guard shack be provided by the contractor. Cost for man and dog per hour.					
Short term (1 week to 1 month)	—	Hr	—	—	52.30
Long term (1 to 6 months)	—	Hr	—	—	37.50
Septic Sewer Systems, Subcontract Soils testing (percolation test) by qualified engineer (required by some communities when applying for septic system permit). Does not include application fee.					
Minimum cost	—	Ea	—	—	2,480.00
Residential septic sewer tanks. Costs include excavation for tank with good site conditions, placing of tank, inlet and outlet fittings, and backfill after hookup.					
Steel reinforced concrete tanks					
1,250 gallons (3 or 4 bedroom house)	—	Ea	—	—	2,710.00
1,500 gallons (5 or 6 bedroom house)	—	Ea	—	—	2,870.00
Fiberglass tanks					
1,000 gallons (3 bedroom house)	—	Ea	—	—	2,490.00
1,250 gallons (4 bedroom house)	—	Ea	—	—	2,550.00
1,500 gallons (5 or 6 bedroom house)	—	Ea	—	—	2,760.00
Polyethylene tanks					
500 gallons	—	Ea	—	—	786.00
750 gallons	—	Ea	—	—	1,300.00
1,000 gallons	—	Ea	—	—	1,420.00
1,250 gallons	—	Ea	—	—	2,270.00
1,500 gallons	—	Ea	—	—	2,530.00
Residential septic sewer drain fields (leach lines). Costs include labor, unsaturated paper, piping, gravel, excavation with good site conditions, backfill, and disposal of excess soil. 4" PVC pipe (ASTM D2729) laid in 3' deep by 1' wide trench.					
With 12" gravel base	—	LF	—	—	13.50
With 24" gravel base	—	LF	—	—	15.90
With 36" gravel base	—	LF	—	—	17.40
Add for pipe laid 6' deep	—	LF	—	—	4.56
Add for piping from house to septic tank, and from septic tank to remote drain fields					
4" PVC Schedule 40	—	LF	—	—	9.60
Basic pumping systems for residential waste , including fiberglass basin, pump, installation from septic tank or sewer line, 40' pipe run, and automatic float switch (no electric work or pipe included).					
To 15' head	—	LS	—	—	3,530.00
To 25' head	—	LS	—	—	4,180.00



Sewer, Pipes

	Craft@Hrs	Unit	Material	Labor	Total
To 30' head	—	LS	—	—	5,430.00
Add for high water or pump failure alarm	—	LS	—	—	772.00
Better quality pump system with two alternating pumps, 700 to 800 gallon concrete or fiberglass basin, automatic float switch, indoor control panel, high water or pump failure alarm, explosion proof electrical system but no electric work or pipe.					
Per pump system	—	LS	—	—	10,200.00
Pipe locating service to detect sewage and water leaks, breaks, and stoppages in pipes with diameter of 2" or more. Equipment can't be used where pipe has 90 degree turns. Maximum depth is 18" for cast iron and 30" for vitreous clay.					
Residential 1/2 day rate	—	LS	—	—	485.00
Commercial 1/2 day rate	—	LS	—	—	647.00
Add for each additional pipe entered	—	LS	—	—	76.70
Plus per LF of pipe length	—	LF	—	—	2.79
Add for travel over 15 miles, per mile	—	Ea	—	—	1.05
Sewer Connections, Subcontract Including typical excavation and backfill.					
4" vitrified clay pipeline, house to property line					
Long runs	—	LF	—	—	26.60
Short runs	—	LF	—	—	28.20
6" vitrified clay pipeline					
Long runs	—	LF	—	—	29.60
Short runs	—	LF	—	—	34.80
Street work	—	LF	—	—	70.80
4" PVC sewer pipe, city installed, property line to main line					
Up to 40 feet (connect in street)	—	LS	—	—	3,870.00
Up to 40 feet (connect in alley)	—	LS	—	—	2,800.00
Each foot over 40 feet	—	LF	—	—	86.90
6" PVC sewer pipe, city installed, property line to main line					
Up to 40 feet (connect in street)	—	LS	—	—	6,200.00
Up to 40 feet (connect in alley)	—	LS	—	—	4,440.00
Each foot over 40 feet	—	LF	—	—	139.00
8" PVC sewer pipe, city installed, property line to main line					
Up to 40 feet (connect in street)	—	LS	—	—	8,640.00
Up to 40 feet (connect in alley)	—	LS	—	—	6,730.00
Each foot over 40 feet	—	LF	—	—	176.00
Access Doors					
Metal access doors, concealed metal hinge					
8" x 8"	SW@.363	Ea	22.70	15.40	38.10
14" x 14"	SW@.363	Ea	29.60	15.40	45.00
18" x 18"	SW@.363	Ea	47.60	15.40	63.00
24" x 24"	SW@.363	Ea	58.70	15.40	74.10
ABS access doors, paintable					
6" x 9"	SW@.363	Ea	10.50	15.40	25.90
14" x 14"	SW@.363	Ea	15.40	15.40	30.80
24" x 18"	SW@.363	Ea	62.70	15.40	78.10
24" x 24"	SW@.363	Ea	73.70	15.40	89.10
24" x 18", screen only	—	Ea	20.30	—	20.30
24" x 24", screen only	—	Ea	23.20	—	23.20
Tub access doors					
6" x 9", white ABS	SW@.363	Ea	10.50	15.40	25.90
14" x 14", white ABS	SW@.363	Ea	15.50	15.40	30.90
14" x 14", galvanized steel	SW@.363	Ea	23.60	15.40	39.00

Sheet Metal

Craft@Hrs Unit Material Labor Total

Sheet Metal Area Walls Provides light well for basement windows, galvanized, corrugated. Add the cost of excavation and backfill.

12" deep, 6" projection, 37" wide	SW@.410	Ea	38.40	17.40	55.80
18" deep, 6" projection, 37" wide	SW@.410	Ea	50.50	17.40	67.90
24" deep, 6" projection, 37" wide	SW@.410	Ea	68.90	17.40	86.30
30" deep, 6" projection, 37" wide	SW@.410	Ea	78.50	17.40	95.90
Add for steel grille cover	—	Ea	89.30	—	89.30

Sheet Metal Flashing

Aluminum flashing .0175" thickness is commercial grade. Mill finish except as noted.

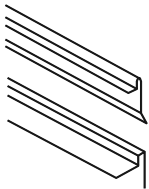

Chimney flash kit (base, cricket & step flash)	SW@.900	Ea	35.90	38.30	74.20
Drip cap, 1-5/8" x 10' x .0175", white	SW@.350	Ea	5.90	14.90	20.80
Drip edge, 2-1/2" x 1" x .0145", 10' long	SW@.350	Ea	4.12	14.90	19.02
Drip edge, 6-1/2" x 1", 10' long	SW@.350	Ea	13.20	14.90	28.10
Flex corner, 2" x 2" x 3-1/2" radius	SW@.050	Ea	3.63	2.13	5.76
Gravel stop, 10' x 5-1/2", "C"-shape	SW@.350	Ea	5.93	14.90	20.83
Roll 6" x 10' x .011"	SW@.400	Ea	6.14	17.00	23.14
Roll 6" x 25' x .0175"	SW@.400	Ea	14.60	17.00	31.60
Roll 8" x 10' x .011"	SW@.400	Ea	7.68	17.00	24.68
Roll 8" x 25' x .0175"	SW@.400	Ea	17.00	17.00	34.00
Roll 10" x 10' x .011"	SW@.400	Ea	9.29	17.00	26.29
Roll 10" x 10' x .0175"	SW@.400	Ea	15.40	17.00	32.40
Roll 14" x 10' x .011"	SW@.400	Ea	11.60	17.00	28.60
Roll 14" x 25' x .0175"	SW@.400	Ea	27.30	17.00	44.30
Roll 20" x 10' x .011"	SW@.400	Ea	14.70	17.00	31.70
Roll 20" x 25' x .0175"	SW@.400	Ea	39.00	17.00	56.00
Roof edge, 2-1/2" x 1-1/2" x 10'	SW@.350	Ea	5.58	14.90	20.48
Roof edge, 4-1/2" x 1-1/2" x 10'	SW@.350	Ea	14.70	14.90	29.60
Sheet, 1' x 1', black	SW@.250	Ea	11.10	10.60	21.70
Sheet, 1' x 1', mill finish	SW@.250	Ea	8.53	10.60	19.13
Sheet, 1' x 2', black	SW@.250	Ea	19.80	10.60	30.40
Sheet, 1' x 2' x .020", lincaine perforated	SW@.250	Ea	20.80	10.60	31.40
Sheet, 2' x 3', mill finish	SW@.500	Ea	13.20	21.30	34.50
Sheet, 3' x 3', mill finish	SW@.500	Ea	22.60	21.30	43.90
Sheet, 3' x 3', lincaine perforated	SW@.500	Ea	41.20	21.30	62.50
Step flashing bent, 2-1/2" x 2-1/2" x 7"	SW@.040	Ea	.58	1.70	2.28
Step flashing, bent, 4" x 4" x 8"	SW@.040	Ea	.63	1.70	2.33
Step flashing, bent, 5" x 7", pack of 10	SW@.400	Ea	2.94	17.00	19.94
Trim coil 24" x 50', white and black	SW@2.50	Ea	103.00	106.00	209.00
Trim coil nails, box of 800	—	Ea	9.31	—	9.31

Copper flashing 16 ounce per square foot, .021 gauge, bright.

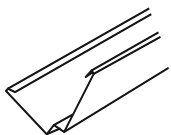

Roll 8" x 20'	SW@.750	Ea	45.00	31.90	76.90
Roll 12" x 20'	SW@.500	Ea	65.20	21.30	86.50
Roll 12" x 20', 3 ounce	SW@1.00	Ea	72.60	42.50	115.10
Roof edging, 1-1/2" x 2" x 10'	SW@.350	Ea	91.70	14.90	106.60
Roof edging, 2" x 2" x 10'	SW@.350	Ea	105.00	14.90	119.90
Roof-to-wall flashing, 4" x 6" x 10'	SW@.350	Ea	251.00	14.90	265.90
Shingle flashing, 8" x 12"	SW@.040	Ea	29.30	1.70	31.00
Step flashing, 5" x 7"	SW@.040	Ea	13.80	1.70	15.50
W-valley flashing, 18" x 10'	SW@.500	Ea	369.00	21.30	390.30
Copper nails, 1-1/4", box of 100	—	Box	23.70	—	23.70

Sheet Metal, Flashing

	Craft@Hrs	Unit	Material	Labor	Total
Plastic/poly-backed copper flashing 3 ounce per square foot. Compatible with ACQ-treated lumber. Laminated to plastic/poly backing.					
Roll 8" x 20'	SW@.500	Ea	43.50	21.30	64.80
Roll 10" x 20'	SW@.500	Ea	51.40	21.30	72.70
Roll 12" x 20'	SW@.500	Ea	67.20	21.30	88.50
Galvanized steel flashing Galvanized mill (plain) finish except as noted. 26 gauge. Galvanized steel flashing has a zinc coating which resists corrosion. Bonderized steel flashing adds a colored phosphate coating which improves paint adhesion.					
ACQ-compatible flashing, 8" x 20'	SW@1.00	Ea	41.40	42.50	83.90
ACQ-compatible flashing, 10" x 20'	SW@1.00	Ea	57.60	42.50	100.10
Angle flashing, 3" x 5" x 10', 90-degree	SW@.500	Ea	11.50	21.30	32.80
Angle flashing, 4" x 4" x 10', 90-degree	SW@.500	Ea	9.75	21.30	31.05
Angle flashing, 6" x 6" x 10', 90-degree	SW@.500	Ea	14.00	21.30	35.30
Angle hem flashing, 4" x 3-1/2" x 10'	SW@.400	Ea	11.00	17.00	28.00
Chimney flash kit (base/cricket/step)	SW@.900	Ea	35.40	38.30	73.70
Counter flash, 1/2" x 6" x 10', bonderized	SW@.400	Ea	35.10	17.00	52.10
Deck ledger, 2" x 2" x 10', ACQ lumber	SW@.400	Ea	11.30	17.00	28.30
Deck ledger, 2" x 2" x 8', galvanized	SW@.350	Ea	8.36	14.90	23.26
Dormer flashing, 7", black	SW@.250	Ea	15.70	10.60	26.30
Dormer flashing, 7", mill finish	SW@.250	Ea	11.80	10.60	22.40
Drip cap, 1-1/2" x 10'	SW@.400	Ea	4.94	17.00	21.94
Drip edge, 2-1/2" x 1" x 10', white	SW@.400	Ea	6.54	17.00	23.54
Drip edge, 5" x 2" x 10', mill finish	SW@.400	Ea	9.34	17.00	26.34
Drip edge, 6" x 10', Beige,	SW@.400	Ea	12.80	17.00	29.80
Endwall flashing, 3" x 4" x 10'	SW@.400	Ea	14.30	17.00	31.30
Fascia cap, 2" x 10', bonderized	SW@.400	Ea	11.50	17.00	28.50
Fungus preventer, 2-1/2" x 50' zinc strip	SW@1.25	Ea	32.10	53.20	85.30
Girder shield flashing, 2" x 8" x 2" x 10'	SW@.400	Ea	15.40	17.00	32.40
Gravel guard, 6" x 10', type "E"	SW@.400	Ea	8.40	17.00	25.40
Gravel stop, 2" x 4" x 10', bonderized	SW@.400	Ea	13.60	17.00	30.60
Gravel stop, 2" x 4" x 10', galvanized	SW@.400	Ea	11.70	17.00	28.70
Gutter apron, 2' x 3' x 10', galvanized	SW@.400	Ea	23.40	17.00	40.40
Gutter apron, 2" x 3" x 10', bonderized	SW@.400	Ea	10.10	17.00	27.10
Half round square dormer, 12" x 12"	BC@.871	Ea	68.00	32.80	100.80
L-flashing, 2" x 2" x 10', bonderized	SW@.400	Ea	9.20	17.00	26.20
L-flashing, 2" x 2" x 10', galvanized	SW@.400	Ea	7.97	17.00	24.97
L-flashing, 4" x 6" x 10', bonderized	SW@.400	Ea	30.10	17.00	47.10
L-flashing, 4" x 6" x 10', galvanized	SW@.400	Ea	16.50	17.00	33.50
Moss preventer, 2-2/3" x 50', zinc	SW@1.25	Ea	50.10	53.20	103.30
Parapet coping, 2" x 8" x 2" x 10'	SW@.500	Ea	20.40	21.30	41.70
Vent pipe flash cone, 1/2" pipe	SW@.250	Ea	7.74	10.60	18.34
Vent pipe flash cone, 1" pipe	SW@.250	Ea	11.10	10.60	21.70
Vent pipe flash cone, 3" pipe	SW@.311	Ea	12.40	13.20	25.60
Vent pipe flash cone, 4" pipe	SW@.311	Ea	14.30	13.20	27.50
Vent pipe flash cone, 5" pipe	SW@.311	Ea	17.80	13.20	31.00
Rain diverter, 7-1/2" x 10'	SW@.400	Ea	11.80	17.00	28.80
Reglet, 3/4" x 10', snap top, bonderized	SW@.500	Ea	18.20	21.30	39.50
Reglet, 3/4" x 10', snap top, mill finish	SW@.500	Ea	10.20	21.30	31.50
Roll 6" x 10', galvanized	SW@.500	Ea	9.39	21.30	30.69
Roll 7" x 10', galvanized	SW@.500	Ea	11.10	21.30	32.40
Roll 8" x 10', bonderized	SW@.500	Ea	18.90	21.30	40.20
Roll 8" x 50', galvanized	SW@2.50	Ea	33.20	106.00	139.20

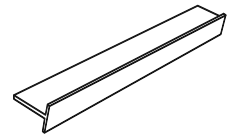

Sheet Metal, Flashing

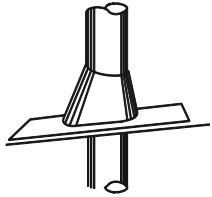

	Craft@Hrs	Unit	Material	Labor	Total
Roll 10" x 10', galvanized	SW@.500	Ea	12.30	21.30	33.60
Roll 14" x 10', galvanized	SW@.500	Ea	20.00	21.30	41.30
Roll 20" x 10', galvanized	SW@.500	Ea	24.60	21.30	45.90
Roll 20" x 50', galvanized	SW@.500	Ea	90.50	21.30	111.80
Roll valley, 20" x 50', gray	SW@2.50	Ea	100.00	106.00	206.00
Roll valley, 20" x 50', brown	SW@2.50	Ea	98.80	106.00	204.80
Roll valley, 30" x 25', galvanized	SW@1.75	Ea	48.70	74.40	123.10
Roll valley, 30" x 50', galvanized	SW@2.50	Ea	77.80	106.00	183.80
Roof apron, 5" x 10', bonderized	SW@.400	Ea	6.79	17.00	23.79
Roof edge, 1" x 2" x 10', brown	SW@.400	Ea	5.49	17.00	22.49
Roof edge, 1" x 2" x 10', gray	SW@.400	Ea	5.49	17.00	22.49
Roof edge, 3" x 3" x 10', brown	SW@.400	Ea	13.30	17.00	30.30
Roof edge, 2" x 2" x 10', weatherwood	SW@.400	Ea	5.65	17.00	22.65
Roof edge, 1-1/2" x 2" x 10', galvanized	SW@.400	Ea	8.42	17.00	25.42
Roof edge, 1-1/2" x 2" x 10', bonderized	SW@.500	Ea	8.42	21.30	29.72
Roof edge, 6" x 6" x 10', galvanized	SW@.400	Ea	22.90	17.00	39.90
Roof grip edge, 2" x 3" x 10', bonderized	SW@.400	Ea	11.70	17.00	28.70
Roof-to-wall flashing, 2" x 3" x 10'	SW@.400	Ea	10.90	17.00	27.90
Roof-to-wall flashing, 4" x 5" x 10'	SW@.400	Ea	22.00	17.00	39.00
Saddle stock, 4" x 14" x 10'	SW@.400	Ea	28.10	17.00	45.10
Sheet 3' x 4', 26-gauge	SW@.500	Ea	24.30	21.30	45.60
Shingle flashing, 5" x 7", box of 10	SW@.400	Box	3.54	17.00	20.54
Starter strip, 4-1/4" x 10', bonderized	SW@.500	Ea	7.39	21.30	28.69
Step flashing, bent 2" x 3" x 7", .031"	SW@.040	Ea	.61	1.70	2.31
Step flashing, bent, 4" x 12", bonderized	SW@.040	Ea	2.27	1.70	3.97
Step flashing, bent, 8" x 8", brown	SW@.040	Ea	.50	1.70	2.20
Trim coil, 24" x 50'	SW@2.50	Ea	130.00	106.00	236.00
Tile roof pan, bent 3-1/2" x 6" x 1/2" x 10'	SW@.400	Ea	25.40	17.00	42.40
Tin repair shingles, 5" x 7", galvanized	SW@.040	Ea	.92	1.70	2.62
Tin repair shingles, 8" x 12", bonderized	SW@.040	Ea	2.04	1.70	3.74
Water table, 1-1/2" x 10', bonderized	SW@.400	Ea	10.90	17.00	27.90
Water table, 1-1/2" x 10', galvanized	SW@.400	Ea	9.93	17.00	26.93
W-valley, 18" x 10', 28 gauge	SW@.500	Ea	32.70	21.30	54.00
W-valley, 20" x 10', 28 gauge, brown	SW@.500	Ea	30.40	21.30	51.70
W-valley, 24" x 10', bonderized	SW@.500	Ea	47.40	21.30	68.70
Z-bar flashing, 1/2" x 1-1/2" x 2" x 10'	SW@.400	Ea	4.22	17.00	21.22
Z-bar flashing, 2" x 5/8" x 1" x 10'	SW@.400	Ea	4.33	17.00	21.33
Z-bar flashing, 2" x 1" x 3" x 10'	SW@.400	Ea	13.80	17.00	30.80

Lead flashing

Roll 8" wide, per linear foot	SW@.050	Ea	4.68	2.13	6.81
Roll 10" wide, per linear foot	SW@.066	Ea	6.13	2.81	8.94
Roll 12" wide, per linear foot	SW@.075	Ea	7.36	3.19	10.55
Vent pipe flash cone, 1-1/2" pipe	SW@.311	Ea	18.40	13.20	31.60
Vent pipe flash cone, 2" pipe	SW@.311	Ea	19.90	13.20	33.10
Vent pipe flash cone, 3" pipe	SW@.311	Ea	23.70	13.20	36.90
Vent pipe flash cone, 4" pipe	SW@.311	Ea	13.20	13.20	26.40

Sheet Metal, Hoods

	Craft@Hrs	Unit	Material	Labor	Total
Vinyl flashing For windows, fascia, soffits, siding and posts in contact with ACQ-treated lumber.					
Deck ledger, J-channel, 4" x 10' x .035"	SW@.350	Ea	14.10	14.90	29.00
Roll 20" x 50', tan	SW@3.50	Ea	56.90	149.00	205.90
Roll 10" x 50', white	SW@2.50	Ea	33.00	106.00	139.00
Roof edge, 1-7/8" x 10'	SW@.400	Ea	9.61	17.00	26.61
Vent pipe flash cone, 1" to 3" pipe	SW@.250	Ea	20.40	10.60	31.00
Vent pipe flash cone, 3" to 4" pipe	SW@.311	Ea	20.40	13.20	33.60
Sheet Metal Hoods					
Entrance hoods, galvanized					
48" x 22" x 12", double mold	SW@1.00	Ea	139.00	42.50	181.50
60" x 24" x 12", double mold	SW@1.00	Ea	132.00	42.50	174.50
48" x 22" x 12", scalloped edge	SW@1.00	Ea	174.00	42.50	216.50
60" x 24" x 12", scalloped edge	SW@1.00	Ea	182.00	42.50	224.50
Side hoods, galvanized, square					
4" x 4"	SW@.190	Ea	13.20	8.08	21.28
6" x 6"	SW@.216	Ea	22.40	9.19	31.59
7" x 7"	SW@.272	Ea	25.10	11.60	36.70
Shelving					
Wood shelving, using 1" thick #3 & Btr paint grade board lumber. Costs shown include an allowance for ledger boards, nails and normal waste. Painting not included. Based on a six foot shelf. For other lengths up to ten feet, use the same labor cost but adjust for material.					
Closet shelves, with 1" diameter clothes pole and pole support brackets each 3' OC					
10" wide shelf, 6'L	BC@.250	Ea	38.00	9.42	47.42
12" wide shelf, 6'L	BC@.250	Ea	41.00	9.42	50.42
18" wide shelf, 6'L	BC@.250	Ea	49.80	9.42	59.22
Linen cabinet shelves, cost of linen closet not included					
18" wide shelf, 6'L	BC@.250	Ea	39.70	9.42	49.12
24" wide shelf, 6'L	BC@.300	Ea	48.60	11.30	59.90
Utility shelves, laundry room walls, garage walls, etc.					
10" wide shelf, 6'L	BC@.250	Ea	26.60	9.42	36.02
12" wide shelf, 6'L	BC@.250	Ea	29.50	9.42	38.92
18" wide shelf, 6'L	BC@.250	Ea	39.70	9.42	49.12
24" wide shelf, 6'L	BC@.300	Ea	48.60	11.30	59.90
Wire shelving kits, vinyl coated steel wire 1" OC. Includes support braces and clamps.					
Heavy-duty garage shelf					
6' x 12"	BC@.800	Ea	21.00	30.10	51.10
6' x 16"	BC@.800	Ea	30.80	30.10	60.90
Linen shelf					
4' x 16"	BC@.600	Ea	28.80	22.60	51.40
Pantry shelf					
6' x 20"	BC@.600	Ea	54.20	22.60	76.80
Closet organizer. Wire shelf above and clothes hanging rack below					
5'-8' wide shelving	BC@1.00	Ea	62.80	37.70	100.50
5' wide, with free-slide clothes	BC@1.00	Ea	136.00	37.70	173.70
Glass shelving kits, includes wall support bracket(s)					
8" x 24" x 3/8", wall, silver support bracket	BC@.400	Ea	36.10	15.10	51.20
8" x 36" x 3/8", wall, silver support bracket	BC@.400	Ea	39.20	15.10	54.30
8" x 48" x 3/8", wall, silver support bracket	BC@.450	Ea	73.80	16.90	90.70
12" x 24" x 3/8", wall, silver support bracket	BC@.400	Ea	48.10	15.10	63.20
12" x 36" x 3/8", wall, silver support bracket	BC@.400	Ea	84.70	15.10	99.80
12" x 48" x 3/8", wall, silver support bracket	BC@.450	Ea	74.70	16.90	91.60
12" x 12", corner, silver support brackets	BC@.500	Ea	16.60	18.70	34.40
Add for opaque glass	—	%	12.7	—	—

Shower and Tub Doors

	Craft@Hrs	Unit	Material	Labor	Total
Glass shelf, 3/8" glass. Add shelf supports below.					
24" x 8", clear	BC@.100	Ea	20.30	3.77	24.07
24" x 12", clear	BC@.100	Ea	21.80	3.77	25.57
36" x 8", clear	BC@.100	Ea	27.40	3.77	31.17
36" x 12", clear	BC@.100	Ea	32.40	3.77	36.17
48" x 8", clear	BC@.100	Ea	30.40	3.77	34.17
48" x 12", clear	BC@.100	Ea	44.60	3.77	48.37
Brackets for glass shelf, per bracket					
Pelican bracket, any color, min 2 per shelf	BC@.250	Ea	8.08	9.42	17.50
Decorator bracket, silver-ish finish	BC@.250	Ea	10.00	9.42	19.42

Shower and Tub Doors

Swinging shower doors, with hardware, tempered safety glass

Minimum quality pivot shower door, 64" high, silver finish frame, obscure glass

28" to 31" wide	BG@1.57	Ea	141.00	57.20	198.20
31" to 34" wide	BG@1.57	Ea	147.00	57.20	204.20

Better quality pivot shower door, 64" high, silver or gold tone frame, obscure glass

24" to 26" wide	BG@1.57	Ea	170.00	57.20	227.20
26" to 28" wide	BG@1.57	Ea	185.00	57.20	242.20
30" to 32" wide	BG@1.57	Ea	193.00	57.20	250.20
32" to 34" wide	BG@1.57	Ea	210.00	57.20	267.20
48" wide	BG@1.57	Ea	275.00	57.20	332.20

Frameless swinging shower doors, to 60" wide by 70" high

1/4" clear glass	BG@1.57	Ea	359.00	57.20	416.20
Silver solstice	BG@1.57	Ea	485.00	57.20	542.20
Nickel solstice	BG@1.57	Ea	528.00	57.20	585.20
Silver clear	BG@1.57	Ea	485.00	57.20	542.20

Sliding shower doors, 2 panels, 5/32" tempered glass, anodized aluminum frame, 70" high, outside towel bar

Non-textured glass, 48" wide	BG@1.57	Ea	328.00	57.20	385.20
Non-textured glass, 56" wide	BG@1.57	Ea	343.00	57.20	400.20
Non-textured glass, 64" wide	BG@1.57	Ea	349.00	57.20	406.20
Texture, opaque, 48" wide	BG@1.57	Ea	375.00	57.20	432.20
Texture, opaque, 56" wide	BG@1.57	Ea	399.00	57.20	456.20
Texture, opaque, 64" wide	BG@1.57	Ea	410.00	57.20	467.20
One panel double mirrored, one bronze tinted	BG@1.57	Ea	424.00	57.20	481.20
Snap-on plastic trim kit, per set of doors	BG@.151	Ea	38.90	5.50	44.40

Sliding shower doors, 2 panels, 1/4" tempered glass, anodized aluminum frame, 70" high, outside towel bar

Non-textured glass, 48" wide	BG@1.57	Ea	450.00	57.20	507.20
Non-textured glass, 56" wide	BG@1.57	Ea	445.00	57.20	502.20
Non-textured glass, 64" wide	BG@1.57	Ea	495.00	57.20	552.20
Frosted opaque design, 48" wide	BG@1.57	Ea	590.00	57.20	647.20
Frosted opaque design, 56" wide	BG@1.57	Ea	623.00	57.20	680.20
Frosted, opaque design, 64" wide	BG@1.57	Ea	656.00	57.20	713.20

Tub doors, two sliding panels, 54" high, to 60" wide opening, with towel bar

Minimum quality, hammered glass	BG@1.77	Ea	141.00	64.50	205.50
Better quality, textured glass	BG@1.77	Ea	203.00	64.50	267.50
5/32-inch glass, silk screen design	BG@1.77	Ea	498.00	64.50	562.50
Frameless with 1/4" clear glass	BG@1.77	Ea	445.00	64.50	509.50
Frameless with 1/4" box lite glass	BG@1.77	Ea	415.00	64.50	479.50
Frameless with 1/4" delta frost glass	BG@1.77	Ea	488.00	64.50	552.50

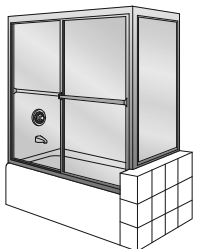

Shower Stalls

Craft@Hrs Unit Material Labor Total

Shower Stalls No plumbing, piping or valves included.

Three-wall molded fiberglass shower stall with integrated soap shelf and textured bottom. White. 72" high. Add the cost of a shower door from the preceding section.

32" x 32"	P1@3.90	Ea	305.00	145.00	450.00
36" x 36"	P1@3.90	Ea	368.00	145.00	513.00
48" x 34"	P1@3.90	Ea	523.00	145.00	668.00
48" x 34" with bench seats	P1@3.90	Ea	577.00	145.00	722.00
60" x 34" with bench seats	P1@3.90	Ea	581.00	145.00	726.00

Neo-angle 2-wall molded fiberglass shower stalls with integrated soap shelf and textured bottom but no door or glass walls. White. 72" high.

38" x 38"	P1@2.50	Ea	718.00	93.10	811.10
Add for neo-angle glass walls and pivot door	P1@1.40	Ea	652.00	52.10	704.10

Neo-angle 4-wall molded fiberglass shower stalls with integrated soap shelf, textured bottom, glass walls and door. 72" high. Obscure glass in an aluminum frame.

38" x 38", chrome frame	P1@3.90	Ea	558.00	145.00	703.00
38" x 38", chrome frame, French glass	P1@3.90	Ea	890.00	145.00	1,035.00
42" x 42", chrome frame	P1@3.90	Ea	991.00	145.00	1,136.00
42" x 42", nickel frame	P1@3.90	Ea	1,240.00	145.00	1,385.00

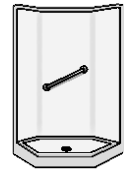

Corner entry shower stall, 2 molded polystyrene walls and a two-panel aluminum-framed sliding glass door. With integrated corner shelves, textured base and drain. White with chrome frame.

32" x 32" x 74"	P1@3.250	Ea	646.00	121.00	767.00
-----------------	----------	----	--------	--------	--------

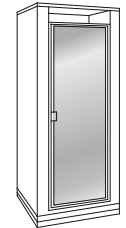

Round shower stall, white aluminum frame and walls, polystyrene sliding door and panel. With soap dishes, 6" textured base, drain and drain cover.

32" x 32" x 74"	P1@3.250	Ea	873.00	121.00	994.00
-----------------	----------	----	--------	--------	--------

Fiberglass shower receptors One-piece molded fiberglass shower floor. Slip resistant with a starburst pattern. Drain molded-in with seal for 2" ABS, PVC, iron pipe and strainer. White. Single threshold 7" high.

36", neo-angle	PM@.600	Ea	168.00	26.30	194.30
38", neo-angle	PM@.800	Ea	191.00	35.10	226.10
32" x 32", square	PM@.600	Ea	116.00	26.30	142.30
36" x 36", square	PM@.600	Ea	127.00	26.30	153.30
32" x 48", rectangular	PM@.800	Ea	144.00	35.10	179.10
34" x 48", rectangular	PM@.800	Ea	171.00	35.10	206.10
34" x 60", rectangular	PM@.800	Ea	183.00	35.10	218.10
Cultured marble receptor, 36" x 48"	PM@2.00	Ea	495.00	87.80	582.80

Shower bed, mortar Includes vapor barrier, lath, mortar and hand floating. Add adjustable floor drain and rough-in plumbing.

Construct built-up mortar shower base	B6@.191	SF	4.06	6.35	10.41
---------------------------------------	---------	----	------	------	-------

Exterior shutters Louvered co-polymer. Price per pair. If needed, add hinges and anchors from the section below.

15" x 39"	BC@.200	Pr	32.60	7.53	40.13
15" x 43"	BC@.200	Pr	35.60	7.53	43.13
15" x 48"	BC@.200	Pr	35.80	7.53	43.33
15" x 52"	BC@.320	Pr	39.70	12.10	51.80
15" x 55"	BC@.320	Pr	42.80	12.10	54.90
15" x 60"	BC@.320	Pr	43.80	12.10	55.90

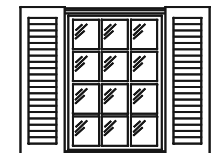

Shutters

Craft@Hrs Unit Material Labor Total

Installation of exterior shutters Figures in the material column show the cost of anchors and hinges.

Installing shutters on hinges

Wood frame construction, 1-3/8" throw

25" to 51" high

BC@.400 Pr 34.70 15.10 49.80

52" to 80" high

BC@.634 Pr 52.10 23.90 76.00

Masonry construction, 4-1/4" throw

25" to 51" high

BC@.598 Pr 55.60 22.50 78.10

52" to 80" high

BC@.827 Pr 74.10 31.10 105.20

Installing fixed shutters, any size

BC@.390 Pr 6.59 14.70 21.29

Shutters, hurricane protection Exterior shutters for residential and commercial applications.

International Building Code Standard D-4355, Dade County Building Code standard E-1886. ASTM D-5621. Tested to ASTM specifications in excess of 150 MPH wind speed. Folding Shutter Corporation Armor Screen. Add for a 30-foot rolling scissor lift, if required, for installation.

Roll-up hurricane shutters, corrugated metal. Includes retractor reel, enclosure box, hand crank, guide rails, above-window aluminum support bar with lag bolt plate and mounting bolts. Electric drive module includes drive motor, switch and 12-volt rechargeable battery pack for power out operation.

Standard window and door sizes

B1@.015 SF 31.60 .51 32.11

Custom window and door sizes

B1@.015 SF 35.50 .51 36.01

Add for optional electric drive, battery & switch

— Ea 1,340.00 — 1,340.00

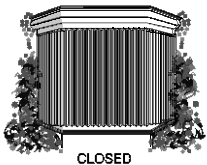

Accordion-type hurricane shutters, flat metal or reinforced vinyl panels. Includes above-window guide-rail mount with bottom rail bearing track, vertical retractor reel, enclosure box, bearing-mounted guide rails, supporting mount plates with lag bolts and hand crank. Electric drive module includes drive motor, switch and 12-volt rechargeable battery pack for power out operation.

Standard window and door sizes

B1@.010 SF 27.60 .34 27.94

Custom window and door sizes

B1@.010 SF 35.50 .34 35.84

Add for optional electric drive, battery & switch

— Ea 1,040.00 — 1,040.00



Fixed corrugated panel hurricane shutters. Galvanized steel, ground anti-cut plastic-coated edges with F-shaped steel and paint-coated vertical mounting tracks. Includes studcons with wing nuts or lag bolt tie-downs and edge-seal water barrier stripping.

Standard window and door sizes

B1@.015 SF 15.00 .51 15.51

Custom window and door sizes

B1@.015 SF 16.30 .51 16.81

Bahama type coated metal, vinyl-coated wood or reinforced vinyl panels. Includes above-window single-panel swivel mount with bottom rail twin support outriggers. Not suitable for covering doors. Secured with either lag bolts or studcons with wing nuts.

Standard window sizes

B1@.012 SF 21.40 .41 21.81

Custom window sizes

B1@.012 SF 27.60 .41 28.01

Colonial type hurricane shutters. Coated metal, vinyl-coated wood, or reinforced vinyl panels. Includes side swivel-mounted twin-panel with hold-open lag bolts or studcons with wing nuts. Deployed mode uses supplied hold-closed barrier bar with tie-down lag bolts or studcons with wing nuts. Not suitable for covering doors.

Standard window sizes

B1@.015 SF 13.90 .51 14.41

Custom window sizes

B1@.015 SF 16.30 .51 16.81

Kevlar window and door hurricane protection. Padded flexible Kevlar or equal plastic fabric secured with lag bolts or studcons with wing nut tie-downs. Secured to wall studs or the window/door frame and removed.

Standard window sizes

B1@.010 SF 30.20 .34 30.54

Custom window sizes

B1@.010 SF 32.70 .34 33.04

Siding

	Craft@Hrs	Unit	Material	Labor	Total
Additional hurricane shutter costs, when applicable.					
Add for Lexan or equal ballistic plastic panels	—	%	15.0	—	—
Add for transparent flexible panels	—	%	10.0	—	—
Add for wind sensor module	—	%	10.0	—	—

Cover window or door with plywood panel Single use, minimum 5/8 inch thickness. Installed with lag bolts or studcons with wing nut tie-downs. Secured to wall studs or the window/door frame and removed.

Per SF or window or door covered	B1@.020	SF	2.05	.68	2.73
----------------------------------	---------	----	------	-----	------

Siding See also Siding in the Lumber Section, Plywood and Hardboard.

Fiber cement lap siding, HardiPlank® 6-1/4" width requires 20 planks per 100 square feet of wall. 7-1/4" width requires 17 planks per 100 square feet of wall. 8-1/4" width requires 15 planks per 100 square feet of wall. 9-1/4" width requires 13 planks per 100 square feet of wall. 12" width requires 10 planks per 100 square feet of wall. Material price includes 10% for waste and fasteners.

6-1/4" x 12', cedarmill	B1@.058	SF	3.17	1.98	5.15
6-1/4" x 12', smooth	B1@.058	SF	2.76	1.98	4.74
7-1/4" x 12', cedarmill	B1@.052	SF	2.92	1.77	4.69
8-1/4" x 12', colonial roughsawn	B1@.048	SF	2.58	1.64	4.22
8-1/4" x 12', cedarmill	B1@.048	SF	1.75	1.64	3.39
8-1/4" x 12', beaded cedarmill	B1@.048	SF	2.78	1.64	4.42
8-1/4" x 12', beaded	B1@.048	SF	2.36	1.64	4.00
8-1/4" x 12', smooth	B1@.048	SF	2.69	1.64	4.33
9-1/4" x 12', cedarmill	B1@.046	SF	2.96	1.57	4.53
12" x 12', smooth	B1@.042	SF	2.67	1.43	4.10
12" x 12', cedarmill	B1@.042	SF	2.19	1.43	3.62

Fiber cement panel siding Primed, HardiPanel®, 4' x 8' panels. Includes 10% for waste and fasteners.

Sierra, Grooves 8" OC	BC@.042	SF	1.46	1.58	3.04
Stucco	BC@.042	SF	1.78	1.58	3.36

Fiber cement fiber trim Primed cement fiber trim, HardiTrim®, per linear foot

Rustic, 3/4" x 4", 12'	BC@.032	LF	1.88	1.21	3.09
Rustic, 3/4" x 6", 12'	BC@.032	LF	2.15	1.21	3.36
Smooth, 5/4" x 4", 10'	BC@.032	LF	2.07	1.21	3.28
Smooth, 5/4" x 6", 10'	BC@.032	LF	2.69	1.21	3.90

Fiber cement fiber soffit Primed cement fiber soffit, James Hardie

Solid, 1/4" x 4' x 8' panel	BC@.031	SF	1.98	1.17	3.15
Vented, 1/4" x 12" wide	BC@.031	LF	2.87	1.17	4.04

Hardboard panel siding Cost per square foot including 5% waste. 4' x 8' panels.

7/16" plain panel	B1@.022	SF	1.36	.75	2.11
7/16" grooved 8" OC	B1@.022	SF	1.68	.75	2.43
7/16" Sturdi-Panel grooved 8" OC	B1@.022	SF	1.12	.75	1.87
7/16" cedar, grooved 8" OC	B1@.022	SF	1.32	.75	2.07
7/16" cedar, plain, textured	B1@.022	SF	1.57	.75	2.32
15/32" Duratemp, grooved 8" OC	B1@.022	SF	1.85	.75	2.60
5/16" SmartSide, grooved 8" OC	B1@.022	SF	1.37	.75	2.12
Add for 4' x 9' panels	—	SF	.27	—	.27

Siding

	Craft@Hrs	Unit	Material	Labor	Total
Hardboard lap siding Primed plank siding. With 8% waste, 6" x 16' covers 5.6 square feet, 8" x 16' covers 7.4 square feet, 9-1/2" x 16' covers 9.7 square feet.					
7/16" x 6" x 16', smooth lap	B1@.033	SF	1.30	1.13	2.43
7/16" x 6" x 16', textured cedar	B1@.033	SF	1.81	1.13	2.94
7/16" x 8" x 16', textured cedar	B1@.031	SF	1.38	1.06	2.44
7/16" x 8" x 16', smooth	B1@.031	SF	2.05	1.06	3.11
1/2" x 8" x 16', self-aligning	B1@.031	SF	2.06	1.06	3.12
1/2" x 8" x 16', old mill sure lock	B1@.031	SF	2.35	1.06	3.41
3/8" x 8" x 16', smartside lap siding	B1@.031	SF	2.11	1.06	3.17
7/16" x 6" joint cover	—	Ea	.73	—	.73
7/16" x 6" corner	—	Ea	1.12	—	1.12
7/16" x 8" joint cover	—	Ea	1.37	—	1.37
7/16" x 8" corner	—	Ea	1.39	—	1.39
7/16" x 9-1/2" joint cover	—	Ea	1.34	—	1.34
7/16" x 9-1/2" corner	—	Ea	1.44	—	1.44
OSB siding Oriented strand board. Includes 6% waste.					
Lap siding, smooth finish					
3/8" x 8" x 16' (190 LF per Sq)	B1@.033	SF	1.95	1.13	3.08
Lap siding, rough-sawn finish					
7/16" x 6" x 16' (250 LF per Sq)	B1@.033	SF	2.60	1.13	3.73
7/16" x 8" x 16' (190 LF per Sq)	B1@.031	SF	2.14	1.06	3.20
Smart Panel II siding					
3/8" x 4' x 8', smooth	B1@.022	SF	1.41	.75	2.16
3/8" x 4' x 9', 8" grooved	B1@.022	SF	1.53	.75	2.28
7/16" x 4' x 8', 4" grooved	B1@.022	SF	2.05	.75	2.80
7/16" x 4' x 8', 8" grooved	B1@.022	SF	1.92	.75	2.67
5/8" x 4' x 8', borate treated	B1@.022	SF	2.50	.75	3.25
Primed Smart Trim. Per linear foot of trim, including 10% waste.					
4/4" x 4" x 16'	B1@.012	LF	1.91	.41	2.32
4/4" x 6" x 16'	B1@.017	LF	2.68	.58	3.26
4/4" x 8" x 16'	B1@.021	LF	2.87	.72	3.59
Pre-stained finish, Olympic machine coat, any of 85 colors, factory applied					
One-coat application, 5-year warranty	—	SF	.20	—	.20
Two-coat application, 10-year warranty	—	SF	.28	—	.28
Oriented strand board soffit panels. Textured Smart Soffit. Including 10% waste.					
3/8" x 4" x 8'	B1@.033	SF	1.68	1.13	2.81
Plywood siding 4' x 8' panels. Includes caulking, nails and 6% waste. For T1-11 siding, see Plywood in the Lumber section.					
11/32" satin bead	B1@.025	SF	1.05	.85	1.90
3/8" plybead, 16" grooved	B1@.025	SF	1.08	.85	1.93
3/8" southern pine	B1@.025	SF	1.08	.85	1.93
3/8" premium plain fir	B1@.025	SF	1.37	.85	2.22
15/32" primed, 8" grooved	B1@.025	SF	1.31	.85	2.16
15/32" fir, 8" grooved	B1@.025	SF	1.53	.85	2.38
19/32" primed, 8" grooved	B1@.025	SF	1.82	.85	2.67
5/8" rough sawn pine	B1@.025	SF	1.66	.85	2.51
5/8" premium fir	B1@.025	SF	2.21	.85	3.06
Yellow pine 4' x 8' plywood batten siding. Battens are 10" wide each 12" on center. Includes caulking, nails and 6% waste.					
19/32" thick	B1@.025	SF	1.38	.85	2.23
5/8" ACQ treated	B1@.025	SF	2.21	.85	3.06

Siding

	Craft@Hrs	Unit	Material	Labor	Total
Aluminum sheet siding					
Aluminum corrugated 4-V x 2-1/2", plain or embossed finish. Includes 15% waste and coverage loss.					
17 gauge, 26" x 6' to 24'	B1@.034	SF	3.12	1.16	4.28
19 gauge, 26" x 6' to 24'	B1@.034	SF	3.23	1.16	4.39
Rubber filler strip, 3/4" x 7/8" x 6'	—	LF	.42	—	.42
Flashing for corrugated aluminum siding, embossed					
End wall, 10" x 52"	B1@.048	Ea	5.57	1.64	7.21
Side wall, 7-1/2" x 10'	B1@.015	LF	2.40	.51	2.91
Aluminum smooth 24 gauge, horizontal patterns, non-insulated					
8" or double 4" widths, acrylic finish	B1@2.77	Sq	222.00	94.50	316.50
12" widths, bonded vinyl finish	B1@2.77	Sq	225.00	94.50	319.50
Add for foam backing	—	Sq	41.00	—	41.00
Starter strip	B1@.030	LF	.54	1.02	1.56
Inside and outside corners	B1@.033	LF	1.61	1.13	2.74
Casing and trim	B1@.033	LF	.54	1.13	1.67
Drip cap	B1@.044	LF	.55	1.50	2.05
Galvanized steel siding					
28 gauge, 27-1/2" wide (includes 20% coverage loss)					
6' to 12' standard lengths	B1@.034	SF	1.72	1.16	2.88
26 gauge, 26" wide (includes 15% coverage loss)					
6' to 12' standard lengths	B1@.034	SF	2.10	1.16	3.26
Shingle siding					
Cedar sidewall shingles, bundle covers 25 square feet, 16" long, 7-1/2" exposure, 5 shingles are 2" thick (5/2)					
#2 Western red cedar	B1@3.86	Sq	276.00	132.00	408.00
Bleached cedar, rebuttet and re-jointed	B1@3.86	Sq	423.00	132.00	555.00
Sanded cedar	B1@3.86	Sq	506.00	132.00	638.00
Grooved cedar	B1@3.86	Sq	505.00	132.00	637.00
Primed smooth cedar	B1@3.86	Sq	536.00	132.00	668.00
Panelized shingle siding Shakertown, KD, regraded shingle on plywood backing, no waste included.					
8' long x 7" wide single course					
Colonial 1	B1@.033	SF	5.35	1.13	6.48
Cascade	B1@.033	SF	5.16	1.13	6.29
8' long x 14" wide, single course					
Colonial 1	B1@.033	SF	5.35	1.13	6.48
8' long x 14" wide, double course					
Colonial 2	B1@.033	SF	5.86	1.13	6.99
Cascade Classic	B1@.033	SF	5.16	1.13	6.29
Decorative shingles, 5" wide x 18" long, Shakertown, fancy cuts, 9 hand-shaped patterns					
7-1/2" exposure	B1@.035	SF	6.26	1.19	7.45
Deduct for 10" exposure	—	SF	-.68	—	-.68
Vinyl siding Solid vinyl. Embossed wood grain texture.					
Double 4" traditional lap profile, 12' 6" long panels, 8" exposure. Each panel covers 8.33 SF before cutting waste. Case of 24 panels covers 200 square feet. Cost per square (100 square feet).					
.040" thick, lighter colors	B1@3.34	Sq	67.80	114.00	181.80
.040" thick, darker colors and textures	B1@3.34	Sq	93.10	114.00	207.10
.042" thick, lighter colors	B1@3.34	Sq	86.40	114.00	200.40
.042" thick, darker colors and textures	B1@3.34	Sq	91.60	114.00	205.60
.044" thick, most colors and textures	B1@3.34	Sq	89.40	114.00	203.40

Siding

	Craft@Hrs	Unit	Material	Labor	Total
Double 4.5" traditional lap profile, 12' 1" long panels, 9" exposure. Each panel covers 9.09 SF. Case of 22 panels covers 200 square feet. Cost per square (100 square feet).					
.040" thick, most colors	B1@3.34	Sq	91.20	114.00	205.20
.040" thick, darker colors and textures	B1@3.34	Sq	91.20	114.00	205.20
Double 5" traditional lap profile, 12' long panels, 10" exposure. Each panel covers 10 SF. Case of 20 panels covers 200 square feet. Cost per square (100 square feet).					
.042" thick, lighter colors	B1@3.34	Sq	91.20	114.00	205.20
.042" thick, darker colors and textures	B1@3.34	Sq	91.20	114.00	205.20
Rigid PVC shingle panel lap siding. 3/4" thick. Cost per square (100 square feet).					
5" exposure, 6-1/2" x 5' panels	B1@3.34	Sq	353.00	114.00	467.00
7" exposure, 8-1/2" x 5' panels	B1@3.34	Sq	377.00	114.00	491.00
Trim for vinyl siding					
Starter strip, 2-1/4" x 12.6'	B1@.030	LF	.49	1.02	1.51
"J"-channel trim at wall openings, 12.5' long	B1@.033	LF	.52	1.13	1.65
Outside or inside corner, 10' long	B1@.033	LF	2.18	1.13	3.31
Casing and trim, 12.5' long	B1@.033	LF	.57	1.13	1.70
Mini mounting block, 4" x 6"	B1@.350	Ea	12.90	11.90	24.80
Vinyl "J"-block, 7" x 9"	B1@.350	Ea	13.80	11.90	25.70
Add for R-3 insulated vinyl siding	B1@.350	Sq	79.60	11.90	91.50
Thermoplastic resin siding Nailite™ 9/10" thick panels installed over sheathing. Add for trim board, corners, starter strips, "J"-channels and mortar fill. Based on five nails per piece. Includes 10% waste.					
Hand-split shake, 41-3/8" x 18-3/4"	B1@.043	SF	3.52	1.47	4.99
Hand-laid brick, 44-1/4" x 18-5/8"	B1@.043	SF	3.76	1.47	5.23
Hand-cut stone, 44-1/4" x 18-5/8"	B1@.043	SF	3.76	1.47	5.23
Rough sawn cedar, 59-1/4" x 15"	B1@.043	SF	3.90	1.47	5.37
Perfection plus cedar, 36-1/8" x 15"	B1@.043	SF	3.90	1.47	5.37
Ledge trim					
Brick ledge trim	B1@.033	LF	8.11	1.13	9.24
Stone ledge trim	B1@.033	LF	8.11	1.13	9.24
Corners					
Hand-split shake, 4" x 18"	B1@.030	LF	15.50	1.02	16.52
Rough sawn cedar 3" x 26"	B1@.030	LF	16.40	1.02	17.42
Hand-laid brick 4" x 18"	B1@.030	LF	16.40	1.02	17.42
Hand-cut stone 4" x 18"	B1@.030	LF	16.40	1.02	17.42
Perfection plus cedar 3" x 13"	B1@.030	LF	13.60	1.02	14.62
Starter strips					
12' universal	B1@.025	LF	.84	.85	1.69
"J"-channels					
Hand-split shake 3/4" opening	B1@.025	LF	1.23	.85	2.08
Hand-split shake 1-1/4" flexible opening	B1@.027	LF	2.46	.92	3.38
Rough sawn cedar 3/4" opening	B1@.025	LF	.92	.85	1.77
Rough sawn cedar 1-1/4" flexible opening	B1@.027	LF	2.46	.92	3.38
Hand-laid brick 3/4" opening	B1@.025	LF	.92	.85	1.77
Hand-cut stone 3/4" opening	B1@.025	LF	.92	.85	1.77
Perfection plus cedar 3/4" opening	B1@.025	LF	.92	.85	1.77
Thermoplastic siding accessories					
Mortar fill, 12 tubes and 200 LF per carton	—	Ea	41.00	—	41.00
Touch up paint, 6 oz. aerosol can	—	Ea	6.09	—	6.09
Skylights Polycarbonate dome, clear transparent or tinted, roof opening sizes, price each, Crestline Skylights, curb or flush mount, self-flashing. Comfort™					
Single dome, 2' x 2'	B1@2.58	Ea	97.70	88.00	185.70
Single dome, 2' x 4'	B1@2.58	Ea	151.00	88.00	239.00
Double dome, 4' x 4'	B1@2.84	Ea	282.00	96.90	378.90

Skylights

Craft@Hrs Unit Material Labor Total

Tempered over laminated low-E argon gas filled doubled insulated fixed glass skylights. Includes costs for flashing. For installation on roofs with 15- to 85-degree slope. Labor costs are for installation of skylight and flashing. Roll shade costs are for factory attached shades. No carpentry or roofing included.



Operable skylight, Velux®, VS® Comfort™ models. Prices include EDL® flashing.

21-1/2" x 38-1/2", #104	B1@3.42	Ea	1,150.00	117.00	1,267.00
21-1/2" x 46-3/8", #106	B1@3.42	Ea	1,230.00	117.00	1,347.00
21-1/2" x 55", #108	B1@3.42	Ea	1,320.00	117.00	1,437.00
30-5/8" x 38-1/2", #304	B1@3.42	Ea	1,260.00	117.00	1,377.00
30-5/8" x 46-3/8", #306	B1@3.42	Ea	1,320.00	117.00	1,437.00
30-5/8" x 55", #308	B1@3.52	Ea	1,380.00	120.00	1,500.00
44-3/4" x 46-1/2", #606	B1@3.52	Ea	1,490.00	120.00	1,610.00
Add for electric operation	—	%	—	—	225.0
Add for ComfortPlus™ Laminated Low E	—	%	10.0	—	—
Add for roll shade, natural					
21-1/2" x 27-1/2" to 55" width	—	Ea	75.60	—	75.60
30-5/8" x 38-1/2" to 55" width	—	Ea	87.00	—	87.00

Fixed skylight, low-E laminated and tempered insulating glass. Wood frame. Aluminum exterior.

5-5/16" x 46-3/8"	B1@3.42	Ea	285.00	117.00	402.00
21-1/2" x 27-1/2"	B1@3.42	Ea	230.00	117.00	347.00
21-1/2" x 38-1/2"	B1@3.42	Ea	293.00	117.00	410.00
21-1/2" x 46-3/8"	B1@3.42	Ea	327.00	117.00	444.00
30-5/8" x 38-1/2"	B1@3.42	Ea	345.00	117.00	462.00
30-5/8" x 46-3/8"	B1@3.42	Ea	393.00	117.00	510.00
30-5/8" x 55"	B1@3.52	Ea	443.00	120.00	563.00
Add for roll shade, natural					
21-1/2" x 27-1/2" to 70-7/8" width	—	Ea	80.60	—	80.60
30-5/8" x 38-1/2" to 55" width	—	Ea	85.10	—	85.10

Fixed ventilation skylight with removable filter on ventilation flap, Velux® model FSF® ComfortPlus™. Prices include EDL® flashing.

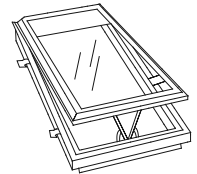

21-1/2" x 27-1/2", #101	B1@3.14	Ea	318.00	107.00	425.00
21-1/2" x 38-1/2", #104	B1@3.14	Ea	371.00	107.00	478.00
21-1/2" x 46-1/2", #106	B1@3.14	Ea	422.00	107.00	529.00
21-1/2" x 70-7/8", #108	B1@3.42	Ea	460.00	117.00	577.00
30-5/8" x 38-1/2", #304	B1@3.14	Ea	454.00	107.00	561.00
30-5/8" x 46-3/8", #306	B1@3.14	Ea	518.00	107.00	625.00
30-5/8" x 55", #308	B1@3.39	Ea	562.00	116.00	678.00
44-3/4" x 27-1/2", #601	B1@3.36	Ea	495.00	115.00	610.00
44-3/4" x 46-1/2", #606	B1@3.39	Ea	652.00	116.00	768.00
Add for roll shade, natural					
21-1/2" x 27-1/2" to 70-7/8" width	—	Ea	90.80	—	90.80
30-5/8" x 38-1/2" to 55" width	—	Ea	103.00	—	103.00

Curb mounted fixed skylight, Velux model FCM™

22-1/2" x 22-1/2", #2222	B1@3.14	Ea	176.00	107.00	283.00
22-1/2" x 34-1/2", #2234	B1@3.14	Ea	231.00	107.00	338.00
22-1/2" x 46-1/2", #2246	B1@3.14	Ea	251.00	107.00	358.00
30-1/2" x 30-1/2", #3030	B1@3.14	Ea	279.00	107.00	386.00
46-1/2" x 46-1/2", #4646	B1@3.14	Ea	427.00	107.00	534.00

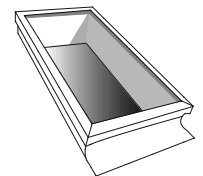

Soffit Systems

Craft@Hrs Unit Material Labor Total

Top hinged roof windows Aluminum-clad wood frame, double insulated tempered over laminated low-E gas filled double insulated glass, including prefabricated flashing, exterior awning, interior roller blind and insect screen. Sash rotates 180 degrees. For installation on roofs with 20- to 55-degree slope. Labor costs are for installation of roof window, flashing and sun screening accessories. No carpentry or roofing work other than curb included. Add for interior trim. Listed by actual unit dimensions, top hung, Velux® model GPL™ Comfort™ Roof Window.

30-5/8" wide x 55" high, #308	B1@3.42	Ea	1,010.00	117.00	1,127.00
44-3/4" wide x 46-3/8" high, #606	B1@3.52	Ea	1,130.00	120.00	1,250.00

Soffit Systems

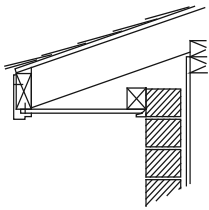

Baked enamel finish, 6" fascia, "J"-channel, 8" perforated or solid soffit, .019 gauge aluminum.

12" soffit	B1@.047	LF	5.09	1.60	6.69
18" soffit	B1@.055	LF	5.90	1.88	7.78
24" soffit	B1@.060	LF	6.70	2.05	8.75
F-channel	B1@.019	LF	.97	.65	1.62

Vinyl soffit systems

12" soffit	B1@.030	LF	4.18	1.02	5.20
18" soffit	B1@.030	LF	4.81	1.02	5.83
24" soffit	B1@.030	LF	5.42	1.02	6.44
F-channel	B1@.019	LF	.82	.65	1.47

Aluminum fascia alone

4" fascia	B1@.030	LF	1.27	1.02	2.29
6" fascia	B1@.030	LF	1.54	1.02	2.56
8" fascia	B1@.030	LF	1.80	1.02	2.82

Soil Testing

Field observation and testing

Soil technician (average)	—	Hr	—	—	67.60
---------------------------	---	----	---	---	-------

Soil testing, per test

Moisture retention	—	Ea	—	—	38.60
Bulk density (loose or core)	—	Ea	—	—	28.80
Porosity	—	Ea	—	—	45.30
Organic matter	—	Ea	—	—	39.20
Plasticity (Liquid and Plastic Limit)	—	Ea	—	—	61.80
Water holding capacity	—	Ea	—	—	38.20
Herbicide detection	—	Ea	—	—	61.80
Complete mineral analysis	—	Ea	—	—	77.20

Foundation investigation (bearing capacity, lateral loads, piles, seismic, stability, settlement for design purposes) and preliminary soils investigation (depth of fill, classification and profile of soil, expansion, shrinkage, grading, drainage recommendations). Including drilling and sampling costs.

Drill rig (driller and helper)	—	Hr	—	—	160.00
Staff engineer	—	Hr	—	—	77.20
Project engineer, RCE	—	Hr	—	—	92.80
Principal engineer	—	Hr	—	—	154.00
Transportation	—	Mile	—	—	1.34
Transportation	—	Hr	—	—	15.50
Laboratory testing (general)	—	Hr	—	—	77.20
Laboratory testing (varies on individual test basis)	—	Ea	—	—	56.60

Report preparation

Analysis, conclusions, recommendations	—	Ea	—	—	2,300.00
Court preparation (Principal Engineer)	—	Hr	—	—	181.00
Expert witness court appearance	—	Hr	—	—	310.00
Add for hazardous studies	—	%	—	—	20.0

Soil Treatments, Subcontract

Craft@Hrs Unit Material Labor Total

Soil Treatments, Subcontract Costs based on total square footage inside of, and including, foundation. Includes inside and outside perimeter of foundation, interior foundation walls, and underneath all slabs. Three-plus year re-application guarantee against existence of termites. Use \$300 as a minimum job charge.

Dursban T.C, Primus, or Equity. Mix applied per manufacturers' and state and federal specifications.
 Complete application — SF — — — .48

Solar Photovoltaic Electrical Systems, Subcontract Costs are for solar electric generating systems. These estimates include engineering, installation, application for permits and application for financial incentives, where available. Costs do not consider tax incentives or rebates. Production capacity figures assume 8 hours of sun time daily. Cost will be higher where less sun time is available.

Small remote vacation home system (12 volt DC). 64 watt solar electric module (98 amp hours), digital voltage regulator, mounting rack and wiring.

384 watt-hours per day — LS — — 1,140.00

Larger remote primary home system (120 volt AC). Includes eight storage batteries (1,050 amp hours), voltage regulator, mounting rack, 2,400 watt DC to AC inverter.

2,880 watt-hours per day — LS — — 6,840.00

Basic two room solar power package. Includes three 48 watt PV panels, one 12 amp voltage regulator, one 220 Amp hour battery with hydrocaps, one 600 watt inverter, mounting frame, hardware and two receptacles

12 amp regulator, with 600 watt inverter — LS — — 2,770.00

Small home solar power package. 90% solar powered system for 1,500 SF home. Includes six 60 watt PV panels, one 750 Amp hour battery, 20 amp voltage regulator and DC distribution box and one 2.2 kW inverter. Costs also include one solar hot water system, one water source heat pump, one 19 cubic foot refrigerator freezer, one ringer type washing machine, six 12 volt lights and three 12 volt ceiling fans

20 amp regulator, 12 volt system — LS — — 14,400.00

Medium sized home solar power package. 80% solar powered system for 2,500 SF home. Includes ten 45 watt PV panels, one 750 Amp hour battery, one 30 amp voltage regulator and one 2 kW inverter with charger. Costs also include one solar domestic hot water system and 22 assorted 12 volt light fixtures

30 amp regulator, 12 volt system — LS — — 8,660.00

Grid-connected solar power package. For use when the electric utility company buys excess power (meter spins backward). 102 poly panels (1,768 SF) with inverter and mounting rack. Peak power is 23.5 kW DC and 21.5 kW AC. Annual production is 35,350 kWh. Includes a 5-year warranty and one year of maintenance.

Net-metered 21 kW system — LS — — 80,900.00

Photovoltaic roofing systems Photovoltaic panels and shingles. Converts sunlight into electric energy and distributes it directly to the building. The solar electric roofing products are configured in series or parallel on the roof deck to form an array. The array is then integrated into the roof following standard roofing specifications. Installation time does not include electrical connections.

Architectural or structural standing photovoltaic seam panels

70 watt panel, 58" x 14"	RR@.035	SF	164.00	1.47	165.47
100 watt panel, 45" x 27"	RR@.035	SF	226.00	1.47	227.47
205 watt panel, 60" x 40"	RR@.033	SF	283.00	1.38	284.38
285 watt panel, 65" x 39"	RR@.033	SF	323.00	1.38	324.38

Photovoltaic shingles, 12" x 86" panel

62 watt shingle panel	RR@.230	Ea	309.00	9.63	318.63
144 watt shingle panel	RR@.260	Ea	368.00	10.90	378.90

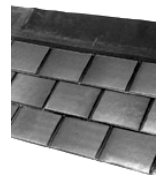

Stairs

	Craft@Hrs	Unit	Material	Labor	Total
Photovoltaic roofing system accessories					
Add for combiner box	—	Ea	538.00	—	538.00
Add for 2.8 kW inverter	—	Ea	1,620.00	—	1,620.00
Add for 3.6 kW inverter	—	Ea	1,830.00	—	1,830.00
Add for 6 volt DC 350 Ah storage batteries	—	Ea	160.00	—	160.00
Add for utility ground fault protection device	—	Ea	309.00	—	309.00

Solar pool heating system

Pool system, eight panels, valves, and piping	—	LS	—	—	5,400.00
Spa system, one panel, valves and piping	—	LS	—	—	1,620.00

Spas, fiberglass, outdoor Includes pump and standard heater. Add the cost of a concrete slab base.

63" x 79", 31 jets	P1@3.50	Ea	3,040.00	130.00	3,170.00
72" x 72", 14 jets	P1@4.00	Ea	2,830.00	149.00	2,979.00
76" x 76", 51 jets	P1@4.00	Ea	3,040.00	149.00	3,189.00
92" x 92", 104 jets	P1@4.00	Ea	5,220.00	149.00	5,369.00
Add for electrical connection	—	Ea	—	—	245.00

Stairs

Factory-cut and assembled straight closed box stairs, unfinished, 36" width

Oak treads with 7-1/2" risers, price per riser					
3'0" wide	B1@.324	Ea	153.00	11.10	164.10
3'6" wide	B1@.324	Ea	198.00	11.10	209.10
4'0" wide	B1@.357	Ea	212.00	12.20	224.20
Deduct for pine treads and plywood risers	—	%	-22.0	—	—
Add for prefinished assembled stair rail with balusters and newel, per riser	B1@.257	Ea	78.70	8.77	87.47
Add for prefinished handrail, with brackets and balusters	B1@.135	LF	27.40	4.60	32.00

Basement stairs, open riser, delivered to job site assembled, 12 treads, 2' 11-3/4" wide

13 risers at 7-13/16" riser height	B1@4.00	Ea	341.00	136.00	477.00
13 risers at 8" riser height	B1@4.00	Ea	350.00	136.00	486.00
13 risers at 8-3/16" riser height	B1@4.00	Ea	359.00	136.00	495.00
Add for handrail	B1@.161	LF	14.30	5.49	19.79

Curved stair, clear oak, self-supporting, 8'6" radii, factory cut, unfinished, unassembled

Open one side (1 side against wall)					
8'9" to 9'4" rise	B1@24.6	Ea	7,930.00	839.00	8,769.00
9'5" to 10'0" rise	B1@24.6	Ea	8,550.00	839.00	9,389.00
10'1" to 10'8" rise	B1@26.5	Ea	9,160.00	904.00	10,064.00
10'9" to 11'4" rise	B1@26.5	Ea	9,820.00	904.00	10,724.00
Open two sides					
8'9" to 9'4" rise	B1@30.0	Ea	14,300.00	1,020.00	15,320.00
9'5" to 10'0" rise	B1@30.0	Ea	15,300.00	1,020.00	16,320.00
10'1" to 10'8" rise	B1@31.9	Ea	16,200.00	1,090.00	17,290.00
10'9" to 11'4" rise	B1@31.9	Ea	17,200.00	1,090.00	18,290.00
Add for newel posts	B1@.334	Ea	98.90	11.40	110.30

Straight stairs, red oak, factory cut, unassembled, 36" tread, includes two 1-1/2" x 3-1/2" handrails and 7/8" round balusters.

70" to 77" with 10 risers	B1@12.0	Ea	2,130.00	409.00	2,539.00
77" to 85" with 11 risers	B1@12.0	Ea	2,410.00	409.00	2,819.00
85" to 93" with 12 risers	B1@12.0	Ea	2,830.00	409.00	3,239.00
93" to 100" with 13 risers	B1@14.0	Ea	2,840.00	478.00	3,318.00
100" to 108" with 14 risers	B1@14.0	Ea	3,080.00	478.00	3,558.00

Stairs

	Craft@Hrs	Unit	Material	Labor	Total
108" to 116" with 15 risers	B1@14.0	Ea	3,250.00	478.00	3,728.00
116" to 124" with 16 risers	B1@16.0	Ea	3,520.00	546.00	4,066.00
124" to 131" with 17 risers	B1@16.0	Ea	3,640.00	546.00	4,186.00
131" to 139" with 18 risers	B1@16.0	Ea	4,070.00	546.00	4,616.00
Add for 44" tread, any of above	—	Ea	134.00	—	134.00
Add for straight rail, unbored	B1@.060	LF	15.90	2.05	17.95
Add for straight nosing	B1@.060	LF	9.89	2.05	11.94
Add for round balusters, 7/8" x 42"	B1@.334	Ea	6.21	11.40	17.61
Add for square balusters, 1-1/8" x 1-1/8" x 44"	B1@.334	Ea	12.80	11.40	24.20
Add for newel posts, 3" x 3" x 44"	B1@.334	Ea	56.10	11.40	67.50
Spiral stairs, red oak, FOB factory, double handrails, 5' diameter					
74" to 82" with 9 risers	B1@16.0	Ea	4,650.00	546.00	5,196.00
82" to 90" with 10 risers	B1@16.0	Ea	4,980.00	546.00	5,526.00
90" to 98" with 11 risers	B1@16.0	Ea	5,060.00	546.00	5,606.00
98" to 106" with 12 risers	B1@16.0	Ea	5,160.00	546.00	5,706.00
106" to 114" with 13 risers	B1@20.0	Ea	5,250.00	682.00	5,932.00
114" to 122" with 14 risers	B1@20.0	Ea	5,460.00	682.00	6,142.00
122" to 130" with 15 risers	B1@20.0	Ea	5,730.00	682.00	6,412.00
Add for 6' diameter	—	%	20.0	—	—
Add for 8'6" diameter	—	%	25.0	—	—
Add for mahogany, any of above	—	%	10.0	—	—
Add for straight rail, unbored	B1@.060	LF	21.10	2.05	23.15
Add for straight nosing, unbored	B1@.060	LF	10.10	2.05	12.15
Add for balusters, 7/8" x 42"	B1@.334	Ea	6.49	11.40	17.89
Add for newel posts 1-7/8" x 44"	B1@.334	Ea	39.00	11.40	50.40
Spiral stairs, aluminum, delivered to job site unassembled, 7-3/4" or 8-3/4" riser heights, 5' diameter					
85-1/4" to 96-1/4" with 10 treads	B1@9.98	Ea	3,290.00	340.00	3,630.00
93" to 105" with 11 treads	B1@10.7	Ea	3,560.00	365.00	3,925.00
100-3/4" to 113-3/4" with 12 treads	B1@11.3	Ea	3,890.00	385.00	4,275.00
108-1/2" to 122-1/2" with 13 treads	B1@12.0	Ea	4,180.00	409.00	4,589.00
116-1/4" to 131-1/4" with 14 risers	B1@12.6	Ea	4,430.00	430.00	4,860.00
124" to 140" with 15 risers	B1@12.8	Ea	4,800.00	437.00	5,237.00
131-3/4" to 148-3/4" with 16 risers	B1@13.5	Ea	5,040.00	460.00	5,500.00
138-1/2" to 157-1/2" with 17 risers	B1@14.2	Ea	5,290.00	484.00	5,774.00
147-1/4" to 166-1/4" with 18 risers	B1@14.8	Ea	5,650.00	505.00	6,155.00
Deduct for 4' diameter	—	%	-20.0	—	—
Deduct for 4'6" diameter	—	%	-10.0	—	—
Add for additional aluminum treads	—	Ea	302.00	—	302.00
Add for oak tread inserts	—	Ea	118.00	—	118.00
Spiral stairs, steel, tubular steel handrail, composition board treads, delivered unassembled, 5' diameter					
86" to 95" with 10 risers	B1@9.98	Ea	2,020.00	340.00	2,360.00
95" to 105" with 11 risers	B1@10.7	Ea	2,230.00	365.00	2,595.00
105" to 114" with 12 risers	B1@11.3	Ea	2,370.00	385.00	2,755.00
114" to 124" with 13 risers	B1@12.0	Ea	2,660.00	409.00	3,069.00
124" to 133" with 14 risers	B1@12.7	Ea	3,020.00	433.00	3,453.00
Deduct for 4' diameter	—	%	-20.0	—	—
Add for 6' diameter	—	%	24.0	—	—
Add for oak treads	—	%	25.0	—	—
Add for oak handrail	—	%	45.0	—	—

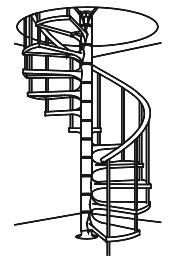

Stairs

Craft@Hrs Unit Material Labor Total

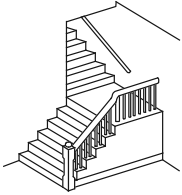

Job-built stairways 3 stringers cut from 2" x 12" Douglas fir material, treads and risers from 3/4" CDX plywood or OSB sheathing. Cost per 7-1/2" rise, 36" wide

Using 2" Douglas fir, per MBF	—	MBF	1,350.00	—	1,350.00
Using 3/4" CDX plywood, per MSF	—	MSF	1,530.00	—	1,530.00
Using 3/4" OSB sheathing, per MSF	—	MSF	1,900.00	—	1,900.00
Using 1" x 6" white pine, per MBF	—	MBF	2,120.00	—	2,120.00
Straight run, 8'0" to 10'0" rise, plywood, per riser	B1@.530	Ea	23.80	18.10	41.90
Straight run, 8'0" to 10'0" rise, OSB, per riser	B1@.530	Ea	27.00	18.10	45.10
"L"- or "U"-shape, plywood, add for landings	B1@.625	Ea	26.70	21.30	48.00
"L"- or "U"-shape, per riser, OSB, add for landings	B1@.625	Ea	29.90	21.30	51.20
Semi-circular, repetitive work, plywood, per riser	B1@.795	Ea	26.70	27.10	53.80
Semi-circular, repetitive work, OSB, per riser	B1@.795	Ea	29.90	27.10	57.00
Landings, from 2" x 6" Douglas fir and 3/4" CDX plywood or 3/4" OSB, surfaced,					
per SF of landing surface, plywood	B1@.270	SF	6.04	9.21	15.25
per SF of landing surface, OSB	B1@.270	SF	6.70	9.21	15.91

Stair treads and risers Unfinished. Including layout, cutting, fitting, and installation of treads, risers and typical tread nosing. Includes a miter return on one side of each tread. 9' rise is usually 14 treads and 15 risers

Yellow pine treads, 11-1/2" x 48"	—	Ea	17.70	—	17.70
Oak treads, 11-1/2" x 48"	—	Ea	41.30	—	41.30
Oak curved first (return) tread, 11-1/2" x 48"	—	Ea	34.90	—	34.90
Oak risers, 8" x 48"	—	Ea	25.60	—	25.60
Oak nosing	—	LF	9.92	—	9.92
Oak treads, risers and nosing for 9' rise stairway	BC@2.50	Ea	1,060.00	94.20	1,154.20
Skirt board with dadoes for treads and risers	BC@3.75	Ea	44.40	141.00	185.40
Skirt board on open side, mitered risers	BC@5.50	Ea	44.40	207.00	251.40
Oak shoe rail with fillet, 1-1/4" plowed, 2-1/2" x 3/4"	BC@.030	LF	3.89	1.13	5.02
Oak landing tread, 1" x 5-1/2"	BC@.180	LF	7.51	6.78	14.29
False treads, 4-3/4" x 16-1/4" x 6"					
Right end	BC@.180	Ea	16.70	6.78	23.48
Left end	BC@.180	Ea	16.70	6.78	23.48
Wall tread, 4-3/4" x 13-1/4"	BC@.180	Ea	20.20	6.78	26.98
False stair tread cap and riser - Repair	BC@.250	Ea	50.30	9.42	59.72
Anti-skid adhesive strips. Peel and stick on wood, concrete or metal.					
2-3/4" x 14"	BC@.050	Ea	4.14	1.88	6.02
4" x 16"	BC@.050	Ea	6.51	1.88	8.39

Stair rails, posts and balusters Unfinished. Including layout, cutting, fitting and installation

Newel posts, 3" x 3" x 48" high					
Half newel, ball top, hemlock	BC@2.50	Ea	33.20	94.20	127.40
Half newel, ball top, oak	BC@2.50	Ea	45.30	94.20	139.50
Starting newel, ball top, hemlock	BC@2.50	Ea	52.30	94.20	146.50
Starting newel, ball top, oak	BC@2.50	Ea	73.30	94.20	167.50
Starting newel, peg top, oak	BC@2.50	Ea	73.50	94.20	167.70
Landing newel, ball top, hemlock	BC@2.50	Ea	57.40	94.20	151.60
Landing newel, ball top, oak	BC@2.50	Ea	98.10	94.20	192.30
Starting newel, peg top, oak	BC@2.50	Ea	104.00	94.20	198.20
Starting newel, ball top, poplar	BC@2.50	Ea	62.00	94.20	156.20

Stairs, Attic

	Craft@Hrs	Unit	Material	Labor	Total
Handrail, 2-3/8" D x 2-1/4" W, set between posts					
Oak, set over newel posts	BC@.150	LF	9.30	5.65	14.95
Oak, set between newel posts	BC@.250	LF	9.30	9.42	18.72
Oak with fillet, set over newel posts	BC@.250	LF	11.00	9.42	20.42
Hemlock, set between newel posts	BC@.150	LF	7.33	5.65	12.98
Poplar, set between newel posts	BC@.150	LF	7.26	5.65	12.91
Hemlock, set over newel posts	BC@.250	LF	7.26	9.42	16.68
Poplar, set over newel posts	BC@.250	LF	7.26	9.42	16.68
Flat bottom, set over newel posts	BC@.250	LF	4.54	9.42	13.96
Balusters, 1-1/4" D x 2-1/4" W, round top					
Oak, 34" high	BC@.330	Ea	10.70	12.40	23.10
Oak, 36" high	BC@.330	Ea	9.14	12.40	21.54
Poplar, 34" high	BC@.330	Ea	7.26	12.40	19.66
Poplar, 36" high	BC@.330	Ea	7.65	12.40	20.05
Hemlock, 31" high, square top	BC@.330	Ea	6.94	12.40	19.34
Hemlock, 34" high, tapered top	BC@.330	Ea	7.71	12.40	20.11
Hemlock, 36" high, tapered top	BC@.330	Ea	8.67	12.40	21.07
Hemlock, 36" high, square top	BC@.330	Ea	8.22	12.40	20.62
Hemlock, 41" high, tapered top	BC@.330	Ea	9.60	12.40	22.00
Hemlock, 41" high, square top	BC@.330	Ea	8.05	12.40	20.45
Handrail easings and transition fittings, oak					
Gooseneck riser	BC@1.75	LF	99.40	65.90	165.30
Upeasing	BC@1.75	Ea	31.60	65.90	97.50
Opening cap	BC@1.75	Ea	25.80	65.90	91.70
Quarter return	BC@1.75	Ea	24.50	65.90	90.40
Volute	BC@1.75	Ea	110.00	65.90	175.90
Turnout	BC@1.75	Ea	61.50	65.90	127.40
Starting easing	BC@1.75	Ea	43.60	65.90	109.50
Over easing	BC@1.75	Ea	31.10	65.90	97.00
Stairs, attic Economy folding stairway, tri-fold design, sanded plywood door, full width main hinge, fir door panel, 3/16" handrail, preassembled, 1" x 4" x 13" treads, 1" x 5" stringer, 22" x 54" opening size					
7' to 8'9" ceiling height, 64" landing	B1@5.00	Ea	139.00	171.00	310.00
8' 9" to 10' ceiling height, 67" landing	B1@5.00	Ea	164.00	171.00	335.00
Economy all-aluminum tri-fold stairway, sanded plywood door, full width main hinge, double-riveted treads, 3/16" handrail, preassembled, 25" x 54" opening size					
8'9" ceiling height, 64" landing	B1@5.00	Ea	244.00	171.00	415.00
10' ceiling height, 67" landing	B1@5.00	Ea	229.00	171.00	400.00
Good quality folding stairway, Bessler Stairways, full width main hinge, fir door panel, molded handrail, preassembled, 1" x 6" treads, 1" x 5" stringer and frame of select yellow pine, "space saver" for narrow openings, 22", 25-1/2", or 30" wide by 54" long					
8'9" or 10' height	B1@5.00	Ea	540.00	171.00	711.00
Superior quality, Bessler Stairways, solid one-piece stringer sliding stairway, stringer and treads of clear yellow pine, unassembled, full-width piano hinge at head of stairs, with springs.					
Compact model 26/26T, for a 22-1/2" x 54" to 22-1/2" x 74" opening, 7'7" to 9'3" height					
1" x 4" stringers and treads	B1@6.00	Ea	1,040.00	205.00	1,245.00
Standard unit, for openings from 25-1/2" x 5'6" to 2'6" x 6'0", 7'7" to 10'10" heights					
1" x 6" stringers and treads	B1@6.00	Ea	1,040.00	205.00	1,245.00
Heavy-duty unit, for openings from 2'6" x 5'10" to 2'6" x 8'0", 7'7" to 12'10" heights					
1" x 8" stringers and treads	B1@9.00	Ea	1,990.00	307.00	2,297.00

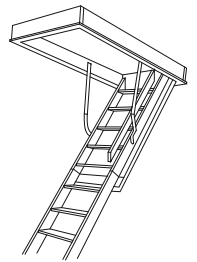

Steam Bath Generators

Craft@Hrs Unit Material Labor Total

Steam Bath Generators Steam bath equipment, 240 volts AC, single phase, UL approved. Costs include steam generator and controls. Labor costs include installation of steam unit and connections to existing supply, steam and drain piping, no rough plumbing or electrical included. Installed in existing, adequately sealed, tub enclosure. Maximum enclosure size as shown. www.amerec.com

4.5kW, 160 cubic feet max	P1@2.50	Ea	1,300.00	93.10	1,393.10
6kW, 180 cubic feet max	P1@2.50	Ea	1,370.00	93.10	1,463.10
7.5kW, 220 cubic feet max	P1@2.50	Ea	1,430.00	93.10	1,523.10
9kW, 260 cubic feet max	P1@2.50	Ea	1,440.00	93.10	1,533.10
10.5kW, 300 cubic feet max	P1@2.50	Ea	1,480.00	93.10	1,573.10
12kW, 360 cubic feet max	P1@2.50	Ea	1,610.00	93.10	1,703.10
20kW, 875 cubic feet max	P1@2.50	Ea	3,650.00	93.10	3,743.10
30kW, 1,275 cubic feet max	P1@2.50	Ea	4,040.00	93.10	4,133.10

Tarpaulins

Polyethylene, heavy duty. Water repellant, with rustproof grommets, cut sizes

6' x 8'	—	Ea	8.80	—	8.80
9' x 9'	—	Ea	14.10	—	14.10
8' x 10'	—	Ea	12.50	—	12.50
12' x 16'	—	Ea	29.80	—	29.80
16' x 20'	—	Ea	50.80	—	50.80
20' x 30'	—	Ea	77.60	—	77.60
40' x 60'	—	Ea	237.00	—	237.00

Canvas, 8 oz.

8' x 10'	—	Ea	57.80	—	57.80
10' x 12'	—	Ea	82.80	—	82.80
10' x 16'	—	Ea	110.00	—	110.00
14' x 20'	—	Ea	226.00	—	226.00
20' x 20'	—	Ea	289.00	—	289.00

Taxes, Payroll

Employer's cost for payroll taxes and insurance, expressed as a percent of total payroll. See also, Insurance for more detailed information.

Rule of thumb: When actual payroll taxes and insurance are not known, estimate that for each \$1 paid in wages the employer must pay an additional \$.30

Payroll taxes and insurance	—	%	—	—	30.0
-----------------------------	---	---	---	---	------

Specific taxes, percent of total payroll

Typical SUI, State unemployment insurance	—	%	—	—	3.40
Typical Disability Insurance (CA, HI, NJ, NY, RI)	—	%	—	—	.90
FICA Social Security 6.20%, Medicare 1.45%	—	%	—	—	7.65
FUTA, Federal Unemployment Insurance	—	%	—	—	.60

Thresholds

Aluminum threshold with vinyl feet

3-3/8" x 5/8" x 36", economy	BC@.515	Ea	7.02	19.40	26.42
3-3/4" x 1" x 36", bronze	BC@.515	Ea	10.40	19.40	29.80
3-3/4" x 1" x 36", silver	BC@.515	Ea	16.70	19.40	36.10
3-1/2" x 5/8" x 72", brown	BC@.730	Ea	27.20	27.50	54.70
3-1/2" x 5/8" x 72", silver	BC@.730	Ea	23.60	27.50	51.10
3-1/2" x 5/8" x 72", gold	BC@.730	Ea	28.90	27.50	56.40

Aluminum bumper threshold with replaceable vinyl insert and vinyl feet

3-3/16" x 5/8" x 36", silver	BC@.515	Ea	16.10	19.40	35.50
3-3/8" x 1" x 36" silver	BC@.515	Ea	11.70	19.40	31.10
3-3/8" x 1" x 36", gold	BC@.515	Ea	23.30	19.40	42.70

Thresholds

	Craft@Hrs	Unit	Material	Labor	Total
3-1/2" x 3/4" x 36", silver	BC@.515	Ea	10.70	19.40	30.10
3-1/2" x 3/4" x 36", gold	BC@.515	Ea	31.60	19.40	51.00
3-3/8" x 1" x 72", silver	BC@.730	Ea	32.70	27.50	60.20
Aluminum saddle interior threshold, smooth flat top, covers floor seams					
1-3/4" x 1/8" x 36", silver	BC@.515	Ea	8.85	19.40	28.25
1-3/4" x 1/8" x 36", gold	BC@.515	Ea	10.70	19.40	30.10
2-1/2" x 1/4" x 36", gold	BC@.515	Ea	8.72	19.40	28.12
Aluminum commercial fluted saddle threshold, UL fire labeled					
5" x 1/2" x 36", mill finish	BC@.515	Ea	20.60	19.40	40.00
5" x 1/2" x 72", mill finish	BC@.730	Ea	44.20	27.50	71.70
Aluminum adjustable threshold, height adjusts from 7/8" to 1-5/16", vinyl top insert and vinyl feet					
3-1/2" x 36", silver	BC@.515	Ea	20.40	19.40	39.80
Aluminum saddle exterior threshold, 1" minimum door clearance, for under-door and drip cap door bottoms.					
3-1/2" x 1" x 36", silver	BC@.515	Ea	13.10	19.40	32.50
4" x 1" x 36", silver	BC@.515	Ea	18.10	19.40	37.50
Aluminum saddle exterior threshold, with vinyl bottom insert					
5" x 36", chrome	BC@.515	Ea	21.90	19.40	41.30
5" x 36", gold	BC@.515	Ea	20.50	19.40	39.90
Oak and aluminum adjustable threshold, height adjusts from 1-1/8" to 1-3/8"					
5-5/8" x 36", silver	BC@.515	Ea	27.90	19.40	47.30
Oak bumper threshold, clear vinyl insert					
3-1/2" x 1" x 36"	BC@.515	Ea	24.00	19.40	43.40
Oak low boy threshold					
3-1/2" x 3/4" x 36"	BC@.515	Ea	13.80	19.40	33.20
3-1/2" x 3/4" x 72"	BC@.730	Ea	37.20	27.50	64.70
Aluminum under-door threshold kit, with vinyl insert.					
1-1/4" x 36", silver	BC@.515	Ea	7.86	19.40	27.26
3-3/4" x 36", gold	BC@.515	Ea	23.60	19.40	43.00
Vinyl replacement threshold insert					
1-7/8" x 36", gray	BC@.100	Ea	2.68	3.77	6.45
1-1/2" x 36", brown	BC@.100	Ea	2.89	3.77	6.66
Oak sill, adjustable, commercial grade, adjusts to accommodate gaps					
1-1/8" x 4-9/16" x 36", in-swing	BC@.750	Ea	31.50	28.20	59.70
1-1/8" x 4-9/16" x 36", out-swing	BC@.750	Ea	57.80	28.20	86.00
Aluminum sill nosing					
1-1/2" x 2-3/4" x 36", silver	BC@.381	Ea	6.30	14.30	20.60
2-3/4" x 4-1/2" x 36", bronze	BC@.381	Ea	14.40	14.30	28.70
2-3/4" x 1-1/2" x 72", mill	BC@.540	Ea	19.70	20.30	40.00
Aluminum sill cover, for use over rough concrete sills					
2-3/4" x 1-1/2" x 36"	BC@.381	Ea	12.80	14.30	27.10
2-3/4" x 1-1/2" x 72"	BC@.540	Ea	13.10	20.30	33.40
Aluminum sill edging					
2-3/4" x 1-1/2" x 36"	BC@.381	Ea	10.80	14.30	25.10
Aluminum door shoe, with vinyl insert					
1-3/8" x 36", brown	BC@.381	Ea	11.50	14.30	25.80
1-3/4" x 36" brown, with drip cap	BC@.381	Ea	13.10	14.30	27.40
Aluminum "L"-shape door bottom, with drip cap and vinyl weather seal					
1-3/4" x 36", gold	BC@.381	Ea	12.00	14.30	26.30

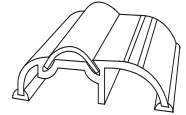

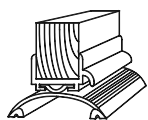

	Craft@Hrs	Unit	Material	Labor	Total
Aluminum "U"-shape door bottom, for exterior doors, with vinyl insert					
1-3/4" x 36"	BC@.381	Ea	14.30	14.30	28.60
1-3/4" x 36", with drip cap	BC@.381	Ea	20.30	14.30	34.60
Aluminum commercial door bottom, UL fire labeled					
36", mill finish	BC@.381	Ea	14.10	14.30	28.40
36", bronze anodized	BC@.381	Ea	12.20	14.30	26.50
Brush door bottom, with brush sweep					
1-3/4" x 36", vinyl	BC@.381	Ea	7.62	14.30	21.92
2-1/8" x 36", rubber	BC@.381	Ea	9.78	14.30	24.08
2" x 36", wood	BC@.381	Ea	12.80	14.30	27.10
Aluminum drip cap door bottom					
1-3/4" x 36", silver	BC@.381	Ea	9.47	14.30	23.77
1-1/2" x 36", heavy duty	BC@.381	Ea	14.40	14.30	28.70
Vinyl slide-on door bottom					
1-3/4" x 36"	BC@.381	Ea	8.11	14.30	22.41
Aluminum and vinyl door bottom					
36", aluminum	BC@.381	Ea	14.00	14.30	28.30
Aluminum door bottom and sweep, interior or exterior doors					
2" x 36", heavy duty	BC@.381	Ea	14.20	14.30	28.50
Oak door sweep, unfinished					
36" wide	BC@.381	Ea	13.20	14.30	27.50



Tile Typical materials costs for common sizes from 4" x 4" to 20" x 20". Subtract 20% for minimum or builder quality tile. Add 25% for better quality tile. Add the cost of mortar or adhesive, grout and labor to install tile from the section below. Costs assume a standard 'checkerboard' layout and 10% breakage and cutting waste. Allow an additional 5% to 10% for any other layout pattern. Tiles can vary greatly in cost. Decorative and imported tile will cost more. See also Shower Stalls.

Ceramic tile					
4-1/4" x 4-1/4", 8 tile cover 1 SF	—	SF	4.03	—	4.03
12" x 12", 1 tile covers 1 SF	—	SF	1.45	—	1.45
16" x 16", 1 tile covers 1.8 SF	—	SF	1.40	—	1.40
18" x 18", 1 tile covers 2.25 SF	—	SF	1.59	—	1.59
Porcelain tile					
6" x 6", 4 tile cover 1 SF	—	SF	4.90	—	4.90
12" x 12", 1 tile covers 1 SF	—	SF	1.95	—	1.95
18" x 18", 1 tile covers 2.25 SF	—	SF	2.36	—	2.36
20" x 20", 1 tile covers 2.8 SF	—	SF	2.01	—	2.01
Travertine tile					
4" x 4", 9 tile cover 1 SF	—	SF	6.66	—	6.66
6" x 6", 4 tile cover 1 SF	—	SF	10.70	—	10.70
12" x 12", 1 tile covers 1 SF	—	SF	3.33	—	3.33
16" x 16", 1 tile covers 1.8 SF	—	SF	2.22	—	2.22
18" x 18", 1 tile covers 2.25 SF	—	SF	3.46	—	3.46
Slate tile					
4" x 4", 9 tile cover 1 SF	—	SF	6.67	—	6.67
12" x 12", 1 tile covers 1 SF	—	SF	1.67	—	1.67
12" x 24", 1 tile covers 2 SF	—	SF	4.68	—	4.68
Marble tile					
6" x 6", 4 tile cover 1 SF	—	SF	9.34	—	9.34
12" x 12", 1 tile covers 1 SF	—	SF	6.82	—	6.82
18" x 18", 1 tile covers 2.25 SF	—	SF	6.69	—	6.69

Tile

	Craft@Hrs	Unit	Material	Labor	Total
Granite tile					
12" x 12", 1 tile covers 1 SF	—	SF	7.98	—	7.98
Glass tile					
2" x 2", 36 tile cover 1 SF	—	SF	36.30	—	36.30
3" x 6", 8 tile cover 1 SF	—	SF	15.30	—	15.30
4" x 4", 9 tile cover 1 SF	—	SF	37.20	—	37.20
Unglazed ceramic tile (pavers), costs do not include sealing					
Minimum quality 'Saltillo'	—	SF	1.10	—	1.10
Good quality 'Paver'	—	SF	1.32	—	1.32
Better quality 'kiln-dried'	—	SF	3.99	—	3.99
Handmade	—	SF	8.30	—	8.30
Handmade, medallion	—	SF	28.80	—	28.80
Mosaic tile, face-mounted or mesh-backed sheets, typically 12" x 12". Costs will vary widely					
Ceramic mosaic tile					
Good quality	—	SF	5.60	—	5.60
Glass mosaic tile					
Good quality	—	SF	15.60	—	15.60
Combination media (glass and stone) mosaic tile					
Good quality	—	SF	14.80	—	14.80
Natural stone mosaic tile					
Good quality	—	SF	18.90	—	18.90
Decorative tile, listellos, pencil liners, mosaic trim, bullnose and accent tiles, etc. Costs will vary widely.					
Bullnose or wall cap tiles					
Good quality, per SF	—	SF	13.50	—	13.50
Good quality, per LF	—	LF	3.08	—	3.08
Listellos, pencil liners					
Good quality	—	LF	4.60	—	4.60
Decorative trim and accent tile					
Typical cost	—	SF	27.30	—	27.30
Ceramic fixtures, glazed.					
Toothbrush/tumbler holder	TL@.250	Ea	7.65	9.00	16.65
Soap dish	TL@.250	Ea	11.20	9.00	20.20
Towel bar assembly, 24" long	TL@.550	Ea	18.30	19.80	38.10
Bath corner shelf, 8" x 8"	TL@.500	Ea	14.80	18.00	32.80
Toilet tissue holder, 4-1/4" x 6"	TL@.250	Ea	30.90	9.00	39.90
Towel ring	TL@.550	Ea	13.40	19.80	33.20
Robe hook	TL@.550	Ea	6.08	19.80	25.88

Tile installation The costs below are for setting and grouting tile only. Smaller and more complex jobs will cost more. Add the cost of preparing the surface for installation (tile backer) and the tile. See Ditra Slab Membrane for detachable membrane costs.

Ceramic tile adhesive. Premixed Type 1, Acryl-4000. 1 gallon covers 70 SF applied with #1 trowel (3/16" x 5/32" "V"-notch), 50 SF applied with #2 trowel (3/16" x 1/4" "V"-notch) or 40 SF applied with #3 trowel (1/4" x 1/4" square-notch).

1 quart	—	Ea	6.12	—	6.12
1 gallon	—	Ea	12.30	—	12.30
3-1/2 gallons	—	Ea	38.50	—	38.50
Tile adhesive applied with #2 trowel	—	SF	.23	—	.23

Tile, Installation

Craft@Hrs Unit Material Labor Total

Thin-set tile mortar. 50 pound bag covers 100 SF applied with #1 trowel (1/4" x 1/4" square-notch), 80 SF applied with #2 trowel (1/4" x 3/8" square-notch), 45 SF applied with #3 trowel (1/2" x 1/2" square notch).

Cost per 50 pound bag.

Standard, gray	—	Ea	5.18	—	5.18
Standard, white	—	Ea	7.77	—	7.77
VersaBond, gray	—	Ea	12.10	—	12.10
VersaBond, white	—	Ea	13.00	—	13.00
FlexiBond, gray	—	Ea	32.80	—	32.80
Marble and granite mix	—	Ea	31.10	—	31.10
VersaBond, gray applied with #3 trowel	—	SF	.27	—	.27

Tile grout. Polymer-modified dry grout for joints 1/16" to 1/2". Coverage varies with tile and joint size.

Typically, a 25 lb. bag of sanded grout will cover 100 SF of 12" x 12" tile with a 1/8" spacing.

CustomBuildingProducts.com offers a grout material calculator.

Unsanded, 10 lb. bag	—	Ea	14.50	—	14.50
Sanded, all colors, 25 lb. bag	—	Ea	14.00	—	14.00
Saltillo grout, gray, 50 lb. bag	—	Ea	14.40	—	14.40

Installation of tile in adhesive Includes adhesive and grout. Adhesive installation not recommended for 'wet' areas. Add the cost of preparing the surface for installation (tile backer) and the cost of tile.

Countertops and backsplashes

Mosaic tile	TL@.203	SF	.31	7.31	7.62
4-1/4" x 4-1/4" to 6" x 6" glazed field tile	TL@.180	SF	.38	6.48	6.86
Countertop trim pieces and edge tile	TL@.180	LF	.08	6.48	6.56

Floors

Mosaic tile	TL@.121	SF	.36	4.36	4.72
6" x 6" to 20" x 20" glazed field tile	TL@.110	SF	.37	3.96	4.33
Floor trim pieces and edge tile	TL@.110	LF	.07	3.96	4.03

Walls

Mosaic tile	TL@.143	SF	.36	5.15	5.51
6" x 6" glazed field tile	TL@.131	SF	.37	4.72	5.09
Wall trim pieces and edge tile	TL@.131	LF	.07	4.72	4.79

Installation of tile in thin-set mortar Includes grout. Costs are for mortar and grout. Add the cost of surface preparation (backerboard) and tile.

Countertops and backsplashes

Mosaic tile	TL@.407	SF	.27	14.70	14.97
4-1/4" x 4-1/4" to 6" x 6" glazed field tile	TL@.352	SF	.27	12.70	12.97
Stone; granite, marble, travertine, 3/8" thick	TL@.455	SF	.53	16.40	16.93
Countertop trim pieces and edge tile	TL@.352	LF	.05	12.70	12.75

Floors

Mosaic tile	TL@.238	SF	.29	8.57	8.86
4-1/4" x 4-1/4" to 6" x 6" glazed field tile	TL@.210	SF	.29	7.56	7.85
8" x 8" to 12" x 12" glazed field tile	TL@.200	SF	.29	7.20	7.49
16" x 16" to 20" x 20" glazed field tile	TL@.200	SF	.30	7.20	7.50
Floor trim pieces and edge tile	TL@.210	LF	.05	7.56	7.61
Quarry or paver tile	TL@.167	SF	.41	6.01	6.42
Stone; granite, marble, travertine, 3/8" thick	TL@.354	SF	.53	12.70	13.23

Walls

Mosaic tile	TL@.315	SF	.53	11.30	11.83
4-1/4" x 4-1/4" to 6" x 6" glazed field tile	TL@.270	SF	.29	9.72	10.01
Stone; granite, marble, travertine, 3/8" thick	TL@.455	SF	.53	16.40	16.93
Wall trim pieces and edge tile	TL@.270	LF	.05	9.72	9.77

Tile Backerboard

Craft@Hrs Unit Material Labor Total

Tile backerboard (Durock™ or Wonderboard™). Water-resistant underlayment for ceramic tile on floors, walls, countertops and other interior wet areas. Material cost for 100 square feet (CSF) of board includes waterproofing membrane, the backerboard (and 10% waste), 50 pounds of job mixed latex-fortified mortar for the joints and surface skim coat, 75 linear feet of fiberglass joint tape, 200 1-1/4" backerboard screws. For scheduling purposes, estimate that a crew of 2 can install, tape and apply the skim coat on the following quantity of backerboard in an 8-hour day: countertops 180 SF, floors 525 SF, and walls 350 SF. Use \$250 as a minimum charge for this type work.

Using 15 Lb. felt waterproofing, per 400 SF roll	—	Roll	24.00	—	24.00
Using 1/4" backerboard, per 100 SF	—	CSF	65.20	—	65.20
Using 1/2" backerboard, per 100 SF	—	CSF	82.30	—	82.30
Using 50 Lb. of latex-fortified mortar each 100 SF, per 50 Lb. sack	—	Sack	12.10	—	12.10
Using 75 LF of backerboard tape each 100 SF, per 50 LF roll	—	Roll	4.93	—	4.93
Using 200 backerboard screws for each 100 SF, per pack of 200 screws	—	Pack	10.80	—	10.80
1/2" Backerboard with waterproofing, mortar, tape and screws					
Floors	T1@.030	SF	1.19	1.00	2.19
Walls	T1@.045	SF	1.19	1.50	2.69
Countertops	T1@.090	SF	1.19	3.00	4.19
1/2" Backerboard with felt, board and fasteners only					
Floors	T1@.018	SF	.95	.60	1.55
Walls	T1@.025	SF	.95	.83	1.78
Subtract for 1/4" backerboard	—	SF	-0.17	—	-0.17

Vacuum Cleaning Systems, Central Subcontract. Costs listed are for better quality central vacuum power unit, piping to 4 remote outlets, hose and attachments (adequate for typical 2,000 SF home). Assumes that all vacuum tubes are installed before any interior finishes are applied.

Basic package with 23' hose	—	LS	—	—	1,670.00
Additional remote outlets	—	Ea	—	—	157.00
Add for electric or turbo power head	—	Ea	—	—	210.00

Vanity cabinets Sink base with no countertop, no lavatory bowl and no plumbing included. Prefinished. See also Countertops and Plumbing. 3/4" furniture-grade sides with veneer interior, overlay doors and drawers, and concealed hinges, 31-1/2" high.

Door only sink base vanity cabinets, white exterior finish. Maple interior finish, concealed hinges.					
18" x 16", 1 door	BC@.400	Ea	84.90	15.10	100.00
24" x 18", 2 doors	BC@.400	Ea	111.00	15.10	126.10
30" x 18", 2 doors	BC@.400	Ea	124.00	15.10	139.10
Standard quality vanity cabinets, veneer doors, drawer front(s) and face frame					
24" x 18", 1 door, 2 drawers	BC@.400	Ea	191.00	15.10	206.10
30" x 18", 1 door, 2 drawers	BC@.400	Ea	212.00	15.10	227.10
36" x 18", 2 doors, 2 drawers	BC@.400	Ea	242.00	15.10	257.10
Good quality vanity cabinets, white or hardwood exterior finish, ball bearing drawer glides					
24" x 21", 1 door, 1-drawer	BC@.400	Ea	330.00	15.10	345.10
30" x 21", 1 door, 4-drawers	BC@.400	Ea	340.00	15.10	355.10
36" x 21", 2 doors, 4 drawers	BC@.400	Ea	379.00	15.10	394.10
48" x 21", 2 doors, 7 drawers	BC@.500	Ea	449.00	18.80	467.80
Premium quality vanity cabinets, cinnamon oak doors and drawer fronts, adjustable hinges					
24" x 21", 1 door, 2 drawer	BC@.400	Ea	294.00	15.10	309.10
30" x 21", 1 door, 2 drawer	BC@.400	Ea	392.00	15.10	407.10
36" x 21", 1 door, 2 drawers	BC@.400	Ea	464.00	15.10	479.10
48" x 21", 1 door, 4 drawers	BC@.500	Ea	615.00	18.80	633.80
60" x 21", 2 doors, 4 drawers	BC@.500	Ea	672.00	18.80	690.80
Over the toilet vanity cabinet, 8" deep x 24" high					
24" wide, 2 doors, 1 shelf	B1@1.37	Ea	136.00	46.70	182.70
30" wide, 2 doors, 1 shelf	B1@1.37	Ea	183.00	46.70	229.70

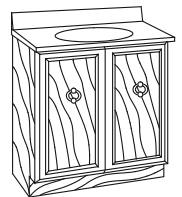

Vents and Louvers

	Craft@Hrs	Unit	Material	Labor	Total
Vents and Louvers					
Attic and gable louver vents, UV stabilized copolymer, screened, rough opening sizes					
12" x 12", 38 sq. inch vent area	SW@.448	Ea	37.70	19.10	56.80
12" x 18", 86 sq. inch vent area	SW@.448	Ea	43.10	19.10	62.20
18" x 24", 140 sq. inch vent area	SW@.871	Ea	54.50	37.00	91.50
21" x 27" oval	SW@.871	Ea	89.50	37.00	126.50
22" x 34", half round, 100 sq. inch vent area	SW@.871	Ea	75.80	37.00	112.80
16" round, 50 sq. inch vent area	SW@.448	Ea	88.60	19.10	107.70
12" x 18", round top 50 sq. inch vent area	SW@.448	Ea	62.70	19.10	81.80
22" octagon, 54 sq. inch vent area	SW@.871	Ea	66.70	37.00	103.70
Chimney caps					
9" x 9" rectangular	SW@.324	Ea	31.80	13.80	45.60
9" x 13" rectangular	SW@.324	Ea	34.80	13.80	48.60
13" x 13" rectangular	SW@.324	Ea	37.80	13.80	51.60
13" x 13" rectangular, stainless	SW@.324	Ea	62.10	13.80	75.90
8" x 8" to 13" x 13" adjustable	SW@.324	Ea	36.90	13.80	50.70
13" x 18" fixed, black	SW@.324	Ea	41.50	13.80	55.30
Clothes dryer vent set, aluminum, with hood, inside plate, 8' of flexible duct pipe, clamps and collar					
4" diameter vent kit	SW@.440	Ea	14.20	18.70	32.90
Flex hose, 4" diameter, 8' length	—	Ea	11.10	—	11.10
Flex hose clamps, 4" diameter	—	Ea	2.26	—	2.26
Code caps					
4" diameter, top only	SW@.324	Ea	26.10	13.80	39.90
6" diameter, top only	SW@.324	Ea	33.30	13.80	47.10
8" diameter, top only	SW@.324	Ea	40.60	13.80	54.40
6" diameter shake base	SW@.324	Ea	31.20	13.80	45.00
8" diameter shake base	SW@.324	Ea	32.50	13.80	46.30
Dormer louver vents, galvanized, 1/4" mesh screen					
19" x 3", low profile, rectangular	BC@.871	Ea	47.30	32.80	80.10
24" x 12", half round	BC@.871	Ea	48.80	32.80	81.60
Add for 1/8" mesh	—	%	3.0	—	—
Under-eave louver vents, rectangular, with 1/4" mesh screen, 16" wide					
16" x 4", mill finish	SW@.255	Ea	1.88	10.80	12.68
16" x 8", mill finish	SW@.255	Ea	2.35	10.80	13.15
16" x 8", brown finish	SW@.255	Ea	2.41	10.80	13.21
16" x 4", white finish	SW@.255	Ea	2.16	10.80	12.96
16" x 8", white finish	SW@.255	Ea	2.28	10.80	13.08
Foundation screen vents, galvanized, with screen, no louvers					
14" x 6"	SW@.255	Ea	3.79	10.80	14.59
16" x 4"	SW@.255	Ea	3.23	10.80	14.03
16" x 6"	SW@.255	Ea	3.50	10.80	14.30
16" x 8"	SW@.255	Ea	3.96	10.80	14.76
Automatic foundation vent, fits 8" x 16" concrete block opening, aluminum mesh on front and molded plastic screen on back. Opens at 72 degrees, closes at 38 degrees. 1" frame each side					
Automatic open and close	SW@.255	Ea	18.60	10.80	29.40
Foundation vent with manual damper, sheet metal					
4" x 16"	SW@.255	Ea	7.77	10.80	18.57
6" x 16"	SW@.255	Ea	8.52	10.80	19.32
8" x 16"	SW@.255	Ea	8.99	10.80	19.79
Foundation access door					
24" x 24"	BC@.363	Ea	33.80	13.70	47.50
32" x 24"	BC@.363	Ea	40.20	13.70	53.90

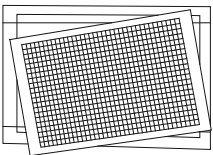

Vents and Louvers

	Craft@Hrs	Unit	Material	Labor	Total
Heater closet door vents, louver					
70 square inches, louvers only	SW@.220	Ea	6.89	9.36	16.25
70 square inches, louvers and screen	SW@.255	Ea	12.70	10.80	23.50
38 square inches, louvers only	SW@.190	Ea	6.70	8.08	14.78
38 square inches, louvers and screen	SW@.210	Ea	10.10	8.93	19.03
Circular louver vents, for moisture control in sidewalls, resin					
2" circular vent	SW@.255	Ea	1.85	10.80	12.65
3" circular vent	SW@.255	Ea	3.67	10.80	14.47
4" circular vent	SW@.255	Ea	3.44	10.80	14.24
Rafter eave vents, galvanized steel with nailing flange, 1/8" mesh, galvanized, louver					
14" x 5"	SW@.220	Ea	4.71	9.36	14.07
14" x 6"	SW@.220	Ea	5.82	9.36	15.18
22" x 3"	SW@.220	Ea	4.60	9.36	13.96
22" x 6"	SW@.220	Ea	6.05	9.36	15.41
22" x 7"	SW@.220	Ea	6.07	9.36	15.43
Rafter bay vent channel, keeps attic insulation away from vents, promotes circulation.					
Rafters 16" on center, 14" wide, 15" net-free vent area	BC@.220	Ea	2.16	8.29	10.45
Rafters 24" on center, 22" wide, 26" net-free vent area	BC@.220	Ea	2.87	8.29	11.16
Ridge ventilators, 1/8" louver opening, double baffle, aluminum					
10' long, black	BC@.650	Ea	20.80	24.50	45.30
10' long, brown	BC@.650	Ea	19.70	24.50	44.20
10' long, white	BC@.650	Ea	19.70	24.50	44.20
4' long, hinged for steep roof	BC@.255	Ea	12.60	9.60	22.20
Joint strap	BC@.010	LF	2.08	.38	2.46
End connector plug	BC@.010	Ea	2.54	.38	2.92
Roof vents, with mesh screen, for roof venting of kitchen and bath exhaust fans					
Square cap type, 26" L x 23" D x 5" H	SW@.448	Ea	60.80	19.10	79.90
Dormer type, 20" L x 10" D x 6" H	SW@.448	Ea	40.00	19.10	59.10
Rotary roof ventilators, with base, by turbine diameter					
12", galvanized	SW@.694	Ea	29.70	29.50	59.20
12", brown	SW@.694	Ea	38.20	29.50	67.70
14", galvanized	SW@.694	Ea	46.60	29.50	76.10
14", brown	SW@.694	Ea	72.10	29.50	101.60
16", galvanized	SW@.930	Ea	114.00	39.60	153.60
18", galvanized	SW@1.21	Ea	133.00	51.50	184.50
Round louver vents, 1/8" mesh, galvanized					
12" or 14" diameter	SW@.440	Ea	52.50	18.70	71.20
16" diameter	SW@.440	Ea	60.40	18.70	79.10
18" diameter	SW@.440	Ea	66.60	18.70	85.30
24" diameter	SW@.661	Ea	119.00	28.10	147.10
Soffit vents, aluminum louvers, 8' long, reversible					
2-5/8" wide, white finish	SW@.440	Ea	5.55	18.70	24.25
2-5/8" wide, mill finish	SW@.440	Ea	3.70	18.70	22.40
Under eave soffit vents, screen type					
4" or 8" x 16"	B1@.500	Ea	10.70	17.10	27.80
Continuous aluminum soffit vents					
2" x 8'	B1@.050	LF	.79	1.71	2.50

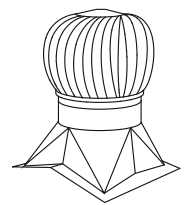
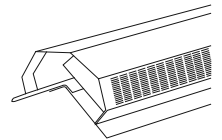

Wallcoverings

	Craft@Hrs	Unit	Material	Labor	Total
Wall louvers, reversible for flush or recessed mounting. White finish. Screened					
12" x 12", aluminum	SW@.440	Ea	11.50	18.70	30.20
12" x 18", aluminum	SW@.440	Ea	14.10	18.70	32.80
14" x 24", aluminum	SW@.440	Ea	21.70	18.70	40.40
18" x 24", aluminum	SW@.440	Ea	24.90	18.70	43.60
12" x 18", plastic	SW@.440	Ea	9.19	18.70	27.89
18" x 24", plastic	SW@.440	Ea	15.60	18.70	34.30



Wallboard Partitions, Subcontract

Costs for interior partitions in one- and two-story buildings. 1/4" gypsum wallboard on 2 sides with "V"-grooved edges and plastic molding at corners fastened to 25 gauge metal framing at 24" OC, including framing, per LF of wall.

Vinyl covered 8' high	—	LF	—	—	48.90
Vinyl covered 10' high	—	LF	—	—	61.10
Paintable paper-covered 8' high	—	LF	—	—	35.60
Paintable paper-covered 10' high	—	LF	—	—	49.50
Add for glued vinyl base on two sides	—	LF	—	—	3.29

Wallcoverings Costs listed are for good to better quality materials installed on a clean, smooth surface and include adhesive, edge trimming, pattern matching, and normal cutting and fitting waste. Surface preparation such as patching and priming are extra. Typical roll is 8 yards long and 18" wide (approximately 36 square feet).

Scrape off old wallpaper, up to 2 layers	PP@.015	SF	—	.52	.52
Paper stripper (1,000 SF per gallon)	—	Gal	14.70	—	14.70
Patch holes, scrape marks	PP@.010	SF	.05	.35	.40
Blank stock (underliner)					
Bath, kitchen, and laundry room	PP@.668	Roll	10.40	23.10	33.50
Other rooms	PP@.558	Roll	10.40	19.30	29.70
Textured basket weave					
Bath, kitchen, and laundry rooms	PP@.995	Roll	25.30	34.40	59.70
Other rooms	PP@.830	Roll	25.30	28.70	54.00
Papers, vinyl-coated papers, trimmed, and pre-pasted					
Bath, kitchen, and laundry rooms	PP@.884	Roll	25.90	30.60	56.50
Other rooms	PP@.780	Roll	25.90	27.00	52.90
Misc. patterns					
Bath, kitchen, and laundry rooms	PP@1.12	Roll	14.20	38.70	52.90
Other rooms	PP@.844	Roll	14.20	29.20	43.40
Designer paper and hand-painted prints					
Bath, kitchen, and laundry rooms	PP@1.68	Roll	71.60	58.10	129.70
Other rooms	PP@1.41	Roll	71.60	48.70	120.30
Murals, no pattern					
Solid vinyl	PP@.844	Yd	24.90	29.20	54.10
Coordinating borders, vinyl coated					
roll is 4" to 6" x 12' to 15'	PP@.017	LF	.98	.59	1.57
Wallpaper adhesive					
Clear, strippable (300 SF per gallon)	—	Gal	22.80	—	22.80
Clear, strippable, per SF	—	SF	.08	—	.08
Mildew-resistant (250 SF per gallon)	—	Gal	15.70	—	15.70
Adhesive, per SF	—	SF	.06	—	.06

Waterproofing

	Craft@Hrs	Unit	Material	Labor	Total
Waterproofing					
Below grade waterproofing, applied to concrete or masonry walls, no surface preparation, excavation, or backfill included, typical job					
Bentonite waterproofing					
One layer, nailed in place	BL@.079	SF	2.21	2.41	4.62
Cementitious waterproofing with protection board					
Spray or brush applied, 2 coats	BL@.077	SF	1.52	2.35	3.87
Crystalline waterproofing					
Spray or brush applied, 3 coats	BL@.110	SF	1.89	3.36	5.25
Elastomeric waterproofing 30 mm per coat					
Sprayed, troweled, or rolled, 2 coats	BL@.065	SF	.34	1.99	2.33
Roll system waterproof membrane 30 mm per coat					
One layer, adhered in place	BL@.079	SF	2.22	2.41	4.63
Waterproof flashing membrane, up to 9" wide	BL@.012	LF	.56	.37	.93
Above grade waterproofing, applied to smooth concrete or plywood deck, no surface preparation included, typical job					
Between slabs membrane					
Sprayed, troweled or rolled, 2 coats	PT@.047	SF	1.27	1.81	3.08
Pedestrian walking surface, elastomeric membrane,					
Applied 4 coats thick with aggregate	PT@.086	SF	2.34	3.32	5.66
Chloroprene/Neoprene latex deck					
Surfacing	PT@.144	SF	4.50	5.55	10.05
Waterproofing system for foundations Wrapped over concrete foundation footing. System should be tied into a perimeter drain system at or around the footing. Cover top of system with at least 6 inches of soil and backfill immediately after installation. No surface preparation, excavation, or backfill included.					
MiraDRI™ 860					
rubberized asphalt membrane	B1@.075	SF	1.04	2.56	3.60
Latex-based primer (400 SF per gal)	B1@.075	SF	.15	2.56	2.71
LM-800 liquid membrane	B1@.034	SF	.32	1.16	1.48
Carlisle 704 mastic,					
1/8" x 3/4", 130 LF per gallon	B1@.034	LF	.14	1.16	1.30
Mira Drain™ 6200 (200 SF Roll)	B1@.075	SF	.35	2.56	2.91
Quick Drain™ (16" x 50' Roll)	B1@.075	SF	3.31	2.56	5.87
Weatherstripping Materials					
Door bottom seals, brass					
Brass "U"-shaped door bottom with adjustment for gaps					
36" x 1-3/8"	BC@.250	Ea	19.40	9.42	28.82
36" x 1-3/4"	BC@.250	Ea	23.50	9.42	32.92
Door frame seal sets					
Spring bronze, nailed every 1-3/8 inch					
36" x 6'8" door	BC@.500	Ea	22.20	18.80	41.00
36" x 7'0" door	BC@.500	Ea	23.50	18.80	42.30
Rigid PVC frame, with silicon bulb / screws	BC@.008	Ea	15.60	.30	15.90
Header and jamb side stripping, adhesive (Peel N Stick®)					
36" x 6'8" door, brass stripping	BC@.500	Ea	30.90	18.80	49.70
Window seal sets, spring brass, adhesive (Peel N Stick®), linear feet per side					
Double hung window, head and sill	BC@.008	LF	1.82	.30	2.12
Add to remove & replace window sash	BC@.250	Ea	—	9.42	9.42
Casement window, head and sill	BC@.008	LF	.80	.30	1.10
Gray or black pile gasket	BC@.008	LF	.40	.30	.70
Gray or black pile gasket with adhesive	BC@.006	LF	.85	.23	1.08
Garage door top and side seal					
Vinyl garage door top and side seal					
9' x 7' door / screws	BC@.500	Ea	23.90	18.80	42.70
16' x 7' door / screws	BC@.600	Ea	31.10	22.60	53.70
Flexible EPDM in aluminum frame	BC@.050	LF	1.88	1.88	3.76

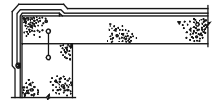
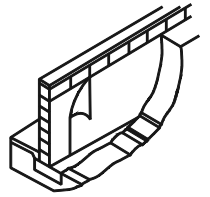

Well Drilling, Subcontract

	Craft@Hrs	Unit	Material	Labor	Total
Garage door bottom seal. Set with adhesive					
'U' shape, vinyl, 2-2/4" wide	BC@.042	LF	.92	1.58	2.50
'U' shape, vinyl, with aluminum door bottom	BC@.064	LF	2.28	2.41	4.69
Blade style, vinyl, 2-1/4"	BC@.042	LF	.98	1.58	2.56
Rodent blocking kit, 1 car garage	BC@3.50	Ea	81.60	132.00	213.60
Rodent blocking kit, 2 car garage	BC@4.00	Ea	156.00	151.00	307.00

Well Drilling, Subcontract Typical costs shown, based on well depth including welded steel casing (or continuous PVC casing). Actual costs will depend on specific conditions, i.e. hard-rock, alluvial riverbed or a combination of conditions. The amount of casing needed depends on soil conditions. Some types of rock require casings at the well surface only. Your local health department can probably provide information on the average well depth and subsurface conditions in the community. Note that unforeseen subsurface conditions can increase drilling costs substantially. Most subcontractors will estimate costs on an hourly basis.

Well hole with 4" ID F480 PVC casing	—	LF	—	—	39.30
Well hole with 6" ID steel casing	—	LF	—	—	69.50
Well hole with 8" ID steel casing	—	LF	—	—	96.90
6" well hole in sturdy rock (no casing)	—	LF	—	—	22.50
Add per well for 6" diameter bottom filter screen, if needed due to site conditions					
Stainless steel	—	LS	—	—	238.00
Low carbon steel	—	LS	—	—	125.00
Add per well for drive shoe	—	LS	—	—	226.00
Add for 6" surface seal, if needed due to local code or site conditions					
20' sanitary seal – for individual well	—	LS	—	—	24.30
50' sanitary seal – for community well	—	LS	—	—	3,770.00
Add per well for well drilling permit. Costs varies per local area.					
Individual water well	—	LS	—	—	679.00
Community water well with Source Assessment	—	LS	—	—	1,800.00
Add for automatic electric pumping system with pressure tank(s) domestic use, no electrical work included.					
Individual (18 GPM @ 400 TDH), typical	—	LS	20,600.00	—	20,600.00
Community (60 GPM @ 400 TDH), typical	—	LS	20,600.00	—	20,600.00
Add for electrical service drop pole					
Typical cost 100 amp 230 volt 1 phase service	—	LS	—	—	1,580.00

Window and Door Mantels, Aluminum Includes hardware, aluminum crown mold and roof. Modern design, bright copper or primed aluminum finish.

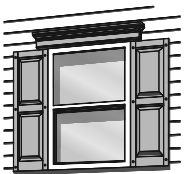

Up to 24" width	SW@.500	Ea	149.00	21.30	170.30
25" to 36" width	SW@.500	Ea	200.00	21.30	221.30
37" to 48" width	SW@.500	Ea	248.00	21.30	269.30
49" to 60" width	SW@.600	Ea	297.00	25.50	322.50
61" to 72" width	SW@.600	Ea	347.00	25.50	372.50
73" to 84" width	SW@.600	Ea	398.00	25.50	423.50
85" to 96" width	SW@.700	Ea	450.00	29.80	479.80
97" to 108" width	SW@.700	Ea	500.00	29.80	529.80
109" to 120" width	SW@.700	Ea	550.00	29.80	579.80
Add for aged copper or brass aluminum finish	—	%	10.0	—	—
Add for units over 120"	—	LF	66.90	—	66.90

Window Sills

	Craft@Hrs	Unit	Material	Labor	Total
Window Sills, Cultured Stone					
Marble sill 40" or less	B1@.687	Ea	58.00	23.40	81.40
Marble sill 41" to 60"	B1@.730	Ea	79.00	24.90	103.90
Onyx sill 40" or less	B1@.687	Ea	79.00	23.40	102.40
Onyx sill 41" to 60"	B1@.730	Ea	110.00	24.90	134.90
Granite sill 40" or less	B1@.687	Ea	95.00	23.40	118.40
Granite sill 41" to 60"	B1@.730	Ea	142.00	24.90	166.90

Window Sills, Vinyl Solid vinyl. Set with latex or solvent base adhesive. Hard, scratch resistant surface. Ultraviolet protection to prevent yellowing. Gloss finish

3-1/2" x 3'	BC@.129	Ea	17.70	4.86	22.56
3-1/2" x 4'	BC@.172	Ea	22.60	6.48	29.08
3-1/2" x 5'	BC@.215	Ea	27.50	8.10	35.60
3-1/2" x 6'	BC@.258	Ea	38.30	9.72	48.02
4-1/4" x 3'	BC@.129	Ea	22.10	4.86	26.96
4-1/4" x 4'	BC@.172	Ea	28.20	6.48	34.68
4-1/4" x 5'	BC@.215	Ea	33.50	8.10	41.60
4-1/4" x 6'	BC@.258	Ea	47.20	9.72	56.92
5-1/2" x 3'	BC@.129	Ea	25.40	4.86	30.26
5-1/2" x 4'	BC@.172	Ea	32.50	6.48	38.98
5-1/2" x 5'	BC@.215	Ea	42.10	8.10	50.20
5-1/2" x 6'	BC@.258	Ea	39.50	9.72	49.22
6-1/4" x 3'	BC@.129	Ea	38.20	4.86	43.06
6-1/4" x 4'	BC@.172	Ea	52.10	6.48	58.58
6-1/4" x 5'	BC@.215	Ea	60.50	8.10	68.60
6-1/4" x 6'	BC@.258	Ea	78.00	9.72	87.72

Window Treatments Blinds and shades. See also Draperies.

Horizontal blinds. Per square foot of blind, width × height. Includes head rail and wand tilter. Standard colors and custom sizes.

1" wide PVC	BC@.083	SF	1.60	3.13	4.73
1" wide aluminum	BC@.083	SF	1.68	3.13	4.81
1" wide basswood	BC@.083	SF	7.09	3.13	10.22
2" wide faux wood	BC@.083	SF	2.54	3.13	5.67
2" wide basswood	BC@.083	SF	5.96	3.13	9.09
2" wide American hardwood	BC@.083	SF	9.47	3.13	12.60
2-1/2" wide faux wood	BC@.083	SF	3.24	3.13	6.37
2-1/2" wide beveled basswood	BC@.083	SF	7.22	3.13	10.35

Roll-up blinds. Per square foot of blind, width × height. Includes aluminum head rail, valance and roller chain lift. Standard colors and custom sizes.

Woven wood (rattan and jute)	BC@.083	SF	6.98	3.13	10.11
Bamboo	BC@.083	SF	6.95	3.13	10.08
Vinyl-fiberglass, translucent	BC@.083	SF	2.32	3.13	5.45
Room darkening fabric	BC@.083	SF	7.38	3.13	10.51
Denim fabric	BC@.083	SF	2.00	3.13	5.13
Decorative woven cotton fabric	BC@.083	SF	3.90	3.13	7.03
Sun control vinyl fiberglass sheer weave	BC@.083	SF	3.88	3.13	7.01

Vertical blinds. 3-1/2" vanes. Per square foot of blind, width × height. Includes aluminum head rail, tension pulley and dust cover valance. Standard colors and custom sizes. Left or right pull.

Smooth surface PVC	BC@.083	SF	2.84	3.13	5.97
Textured surface PVC	BC@.083	SF	3.62	3.13	6.75
Premium textured surface PVC	BC@.083	SF	5.69	3.13	8.82
Faux wood	BC@.083	SF	3.58	3.13	6.71
Add for center pull, per blind	—	Ea	26.10	—	26.10
Add for tile or molding cutout, per blind	—	Ea	26.10	—	26.10
Add for motorized remote control, per blind	—	Ea	131.00	—	131.00

Windows

	Craft@Hrs	Unit	Material	Labor	Total
Cellular shades, polyester. With head rail and mounting hardware.					
3/8" double cell light filter	BC@.083	SF	4.74	3.13	7.87
3/8" single cell translucent	BC@.083	SF	6.62	3.13	9.75
3/8" double cell room darkening	BC@.083	SF	6.05	3.13	9.18
3/8" single cell blackout	BC@.083	SF	7.48	3.13	10.61
1/2" double cell light filter	BC@.083	SF	6.70	3.13	9.83
1/2" single cell light filter	BC@.083	SF	6.44	3.13	9.57
3/4" single cell extreme light	BC@.083	SF	6.99	3.13	10.12
3/4" single cell blackout	BC@.083	SF	9.87	3.13	13.00
Add for width over 8'	—	%	20.0	—	—
Add for continuous loop lift cord	—	%	25.0	—	—
Add for no lift cord (child safety), per blind	—	Ea	46.80	—	46.80
Add for tile or molding cutout, per blind	—	Ea	23.40	—	23.40

Windows See also Skylights.

Single-hung insulating glass vinyl windows. 5/8" insulating glass with grid between the lites. 4/4 grid means the upper lite is divided into four panes and the lower lite is divided into four panes. Tilt sash for easy cleaning. Includes half screen. Dimensions are rough opening sizes, width × height. White finish.



1'8" x 4'2", 4/4 grid	BC@.500	Ea	19.10	18.80	37.90
2'0" x 3'0", 4/4 grid	BC@.500	Ea	110.00	18.80	128.80
2'0" x 6'0", 6/4 grid	BC@.500	Ea	133.00	18.80	151.80
2'8" x 3'0", 6/6 grid	BC@.500	Ea	122.00	18.80	140.80
2'8" x 4'4", 6/6 grid	B1@1.00	Ea	141.00	34.10	175.10
2'8" x 5'0", 6/6 grid	B1@1.00	Ea	144.00	34.10	178.10
2'8" x 6'0", 6/6 grid	B1@1.00	Ea	151.00	34.10	185.10
3'0" x 3'0", 6/6 grid	BC@.500	Ea	127.00	18.80	145.80
3'0" x 4'0", 6/6 grid	B1@1.00	Ea	143.00	34.10	177.10
3'0" x 4'4", 6/6 grid	B1@1.00	Ea	143.00	34.10	177.10
3'0" x 5'0", 6/6 grid	B1@1.50	Ea	160.00	51.20	211.20
3'0" x 6'0", 9/6 grid	B1@1.50	Ea	176.00	51.20	227.20

Single-hung insulated low-E glass vinyl windows. Low-E (energy efficient) 5/8" insulating glass with grids between the glass. 4/4 grid means the upper light is divided into four panes and the lower light is divided into four panes. White finish. Tilt sash for easy cleaning. Includes half screen. Dimensions are rough opening sizes, width × height.

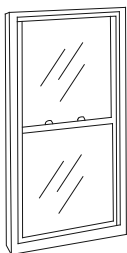

2'0" x 3'0", 4/4 grid	BC@.500	Ea	92.10	18.80	110.90
2'0" x 5'0", 4/4 grid	BC@.500	Ea	157.00	18.80	175.80
2'0" x 6'0", 6/4 grid	B1@1.00	Ea	177.00	34.10	211.10
2'8" x 3'0", 6/6 grid	BC@.500	Ea	131.00	18.80	149.80
2'8" x 4'4", 6/6 grid	B1@1.00	Ea	176.00	34.10	210.10
2'8" x 5'0", 6/6 grid	B1@1.00	Ea	159.00	34.10	193.10
2'8" x 6'0", 9/6 grid	B1@1.50	Ea	194.00	51.20	245.20
3'0" x 3'0", 6/6 grid	BC@.500	Ea	124.00	18.80	142.80
3'0" x 4'0", 6/6 grid	B1@1.00	Ea	164.00	34.10	198.10
3'0" x 4'4", 6/6 grid	B1@1.00	Ea	183.00	34.10	217.10
3'0" x 5'0", 6/6 grid	B1@1.50	Ea	185.00	51.20	236.20
3'0" x 6'0", 9/6 grid	B1@1.50	Ea	205.00	51.20	256.20

Double-hung insulating glass vinyl windows with low-E glass insulating glass. Upper and lower lites are divided into panes by a vinyl grid between the sheets of glass. Sash tilts for easy cleaning. With full screen. 4-9/16" white jamb. Built-in "J"-channel. Designed for new construction. Dimensions are rough opening sizes, width × height.

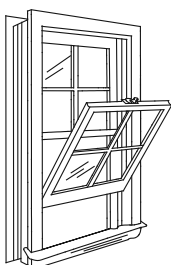

2'4" x 3'2"	BC@.500	Ea	176.00	18.80	194.80
2'4" x 3'10"	BC@.500	Ea	186.00	18.80	204.80
2'4" x 4'2"	BC@.500	Ea	203.00	18.80	221.80
2'4" x 4'6"	BC@.500	Ea	208.00	18.80	226.80

Windows

	Craft@Hrs	Unit	Material	Labor	Total
2'8" x 3'2"	BC@.500	Ea	183.00	18.80	201.80
2'8" x 3'10"	BC@.500	Ea	202.00	18.80	220.80
2'8" x 4'2"	BC@.500	Ea	208.00	18.80	226.80
2'8" x 4'6"	B1@1.00	Ea	212.00	34.10	246.10
3'0" x 4'2"	B1@1.50	Ea	215.00	51.20	266.20
3'0" x 4'6"	B1@1.00	Ea	230.00	34.10	264.10

Double-hung insulating glass vinyl windows. White, with full screen. Low-E (energy-efficient) insulating glass. By rough opening size, width × height. Actual size is 1/2" less. Upper and lower lites are divided into six panes by a vinyl grid between the sheets of glass. 4-9/16" wide jamb.

2'0" x 3'2"	BC@.500	Ea	172.00	18.80	190.80
2'4" x 2'10"	BC@.500	Ea	159.00	18.80	177.80
2'4" x 3'2"	BC@.500	Ea	170.00	18.80	188.80
2'4" x 3'10"	BC@.500	Ea	175.00	18.80	193.80
2'4" x 4'6"	B1@1.00	Ea	196.00	34.10	230.10
2'8" x 2'10"	BC@.500	Ea	175.00	18.80	193.80
2'8" x 3'2"	BC@.500	Ea	170.00	18.80	188.80
2'8" x 3'10"	BC@.500	Ea	181.00	18.80	199.80
2'8" x 4'2"	B1@1.00	Ea	177.00	34.10	211.10
2'8" x 4'6"	B1@1.00	Ea	192.00	34.10	226.10
3'0" x 3'10"	B1@1.00	Ea	218.00	34.10	252.10
3'0" x 4'6"	B1@1.00	Ea	229.00	34.10	263.10

Horizontal sliding single-glazed vinyl windows. By nominal size, width × height. Actual size is 1/2" less.

With screen.

2'0" x 2'0"	BC@.500	Ea	85.20	18.80	104.00
3'0" x 2'0"	BC@.500	Ea	107.00	18.80	125.80
3'0" x 3'0"	BC@.500	Ea	127.00	18.80	145.80
4'0" x 3'0"	B1@1.00	Ea	145.00	34.10	179.10
4'0" x 4'0"	B1@1.50	Ea	171.00	51.20	222.20
5'0" x 4'0"	B1@1.50	Ea	188.00	51.20	239.20

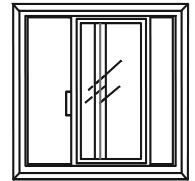

Horizontal sliding insulated low-E glass vinyl windows. Argon filled. For new construction. By rough opening size, width × height. With screen.

2'0" x 2'0"	BC@.500	Ea	98.50	18.80	117.30
2'0" x 3'0"	BC@.500	Ea	107.00	18.80	125.80
2'4" x 4'6"	BC@.500	Ea	174.00	18.80	192.80
2'8" x 4'6"	B1@1.00	Ea	185.00	34.10	219.10
3'0" x 2'0"	BC@.500	Ea	125.00	18.80	143.80
3'0" x 3'0"	BC@.500	Ea	127.00	18.80	145.80
3'0" x 4'0"	B1@1.00	Ea	175.00	34.10	209.10
3'0" x 5'2"	B1@1.50	Ea	200.00	51.20	251.20
3'0" x 6'0"	B1@1.50	Ea	200.00	51.20	251.20
4'0" x 2'0"	BC@.500	Ea	177.00	18.80	195.80
4'0" x 3'0"	B1@1.00	Ea	173.00	34.10	207.10
4'0" x 4'0"	B1@1.50	Ea	174.00	51.20	225.20
5'0" x 4'0"	B1@1.50	Ea	240.00	51.20	291.20

Horizontal sliding replacement windows, white vinyl frame, insulated low-E glass. Argon filled. For existing construction. Set in an existing frame. Including on site measure, custom fabrication, delivery, breakout and disposal of the existing glass. By frame size, width × height. With screen.

2'0" x 2'0" (fixed)	BC@0.75	Ea	198.00	28.20	226.20
3'0" x 2'0" (fixed)	BC@0.85	Ea	213.00	32.00	245.00
3'9" x 2'0" (fixed)	BC@0.90	Ea	235.00	33.90	268.90
5'0" x 4'0" (two lites, half venting)	BC@2.00	Ea	348.00	75.30	423.30
6'0" x 3'6" (two lites, half venting)	BC@2.00	Ea	355.00	75.30	430.30
6'0" x 4'0" (two lites, half venting)	BC@2.00	Ea	380.00	75.30	455.30
6'0" x 4'0" (four lites, 22" x 22" venting)	BC@2.00	Ea	581.00	75.30	656.30
6'0" x 5'0" (two lites, half venting)	BC@2.25	Ea	433.00	84.70	517.70
10'0" x 6'8" door (three lites, one sliding)	BC@8.00	Ea	2,280.00	301.00	2,581.00
Add for color vinyl frame	—	%	10.0	—	—

Windows

Craft@Hrs Unit Material Labor Total

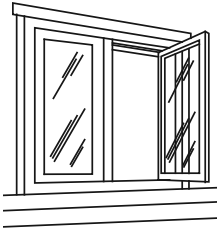

Casement insulated low-E glass vinyl windows. Argon filled. By window size, width × height. With screen. Sash opening direction when viewed from the interior.

28" x 48", left opening	BC@.500	Ea	260.00	18.80	278.80
28" x 48", right opening	BC@.500	Ea	260.00	18.80	278.80
30" x 36", left opening	BC@.500	Ea	310.00	18.80	328.80
30" x 36", right opening	B1@1.00	Ea	310.00	34.10	344.10
30" x 48", right opening	B1@1.00	Ea	354.00	34.10	388.10
30" x 48", right opening	B1@1.00	Ea	354.00	34.10	388.10
36" x 42", right opening	B1@1.50	Ea	338.00	51.20	389.20
36" x 42", left opening	B1@1.50	Ea	338.00	51.20	389.20

Casement bay insulating glass vinyl windows. Fixed center lite and two casement flankers. White vinyl. Factory assembled. By nominal (opening) size, width × height. Actual size is 1/2" less in both width and height. Includes two screens.

69" x 50"	B1@4.00	Ea	1,340.00	136.00	1,476.00
74" x 50"	B1@4.00	Ea	1,350.00	136.00	1,486.00
93" x 50"	B1@4.50	Ea	1,560.00	153.00	1,713.00
98" x 50"	B1@4.50	Ea	1,650.00	153.00	1,803.00

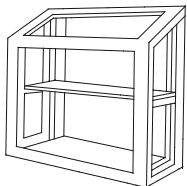

Garden insulating glass vinyl windows. Single front awning vent. White vinyl construction with wood frame. Tempered glass shelf. 5/4" vinyl laminated head and seat board. With hardware and screen. By nominal (opening) size, width × height. Replacement window. Labor includes removing the old stops and sash and setting new "J"-trim as needed.

36" x 36"	B1@2.75	Ea	732.00	93.80	825.80
36" x 36", low-E glass	B1@2.75	Ea	776.00	93.80	869.80
36" x 48", low-E glass	B1@2.75	Ea	842.00	93.80	935.80

Fixed half circle (picture) insulating glass vinyl windows. White frame. Low-E (energy-efficient) glass. Stock units for new construction. By width × height.

20" x 10"	B1@2.75	Ea	612.00	93.80	705.80
30" x 16"	B1@2.75	Ea	612.00	93.80	705.80
40" x 20"	B1@2.75	Ea	817.00	93.80	910.80
50" x 26"	B1@2.75	Ea	965.00	93.80	1,058.80
60" x 30"	B1@2.75	Ea	1,090.00	93.80	1,183.80
80" x 40"	B1@2.75	Ea	1,590.00	93.80	1,683.80

Fixed (picture) low-E insulating glass vinyl windows. Argon filled. White frame. Dimensions are rough opening sizes, width × height.

24" x 36"	BC@.500	Ea	102.00	18.80	120.80
24" x 48"	BC@.500	Ea	132.00	18.80	150.80
24" x 60"	BC@.500	Ea	145.00	18.80	163.80
30" x 36"	BC@.500	Ea	140.00	18.80	158.80
30" x 48"	BC@.500	Ea	142.00	18.80	160.80
36" x 48"	B1@1.00	Ea	145.00	34.10	179.10
36" x 60"	B1@1.00	Ea	176.00	34.10	210.10
48" x 48"	B1@1.50	Ea	174.00	51.20	225.20
48" x 60"	B1@1.50	Ea	192.00	51.20	243.20
60" x 48"	B1@1.50	Ea	201.00	51.20	252.20

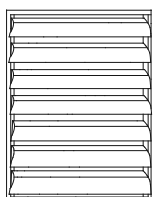

Jalousie (louver) vinyl windows. Positive locking handle for security. By opening size, width × height.

24" x 35-1/2", clear	BC@.500	Ea	346.00	18.80	364.80
24" x 35-1/2", obscure glass	BC@.500	Ea	393.00	18.80	411.80
30" x 35-1/2", clear	BC@.500	Ea	370.00	18.80	388.80
30" x 35-1/2", obscure glass	BC@.500	Ea	425.00	18.80	443.80
36" x 35-1/2", clear	BC@.500	Ea	382.00	18.80	400.80
36" x 35-1/2", obscure glass	BC@.500	Ea	451.00	18.80	469.80

Windows

	Craft@Hrs	Unit	Material	Labor	Total
Hopper insulating glass vinyl windows. Low-E (energy-efficient) insulating glass. Argon filled. Frame depth 3-5/16". By opening size, width × height.					
32" x 15"	BC@.500	Ea	108.00	18.80	126.80
32" x 17"	BC@.500	Ea	115.00	18.80	133.80
32" x 19"	BC@.500	Ea	119.00	18.80	137.80
32" x 23"	BC@.500	Ea	124.00	18.80	142.80
Vinyl-clad double-hung insulating glass wood windows. Pine interior. White vinyl exterior. Tilt sash. By nominal (opening) size, width × height. Actual width is 1-5/8" more. Actual height is 3-1/4" more. Add the cost of screens and colonial grilles.					
2'0" x 3'0"	BC@.500	Ea	210.00	18.80	228.80
2'4" x 3'6"	BC@.500	Ea	247.00	18.80	265.80
2'4" x 4'0"	BC@.500	Ea	270.00	18.80	288.80
2'4" x 4'6"	B1@1.00	Ea	288.00	34.10	322.10
2'4" x 4'9"	B1@1.00	Ea	301.00	34.10	335.10
2'8" x 3'0"	B1@1.00	Ea	240.00	34.10	274.10
2'8" x 3'6"	B1@1.00	Ea	263.00	34.10	297.10
2'8" x 4'0"	B1@1.00	Ea	278.00	34.10	312.10
2'8" x 4'6"	B1@1.00	Ea	304.00	34.10	338.10
2'8" x 4'9"	B1@1.00	Ea	315.00	34.10	349.10
3'0" x 3'6"	B1@1.00	Ea	277.00	34.10	311.10
3'0" x 4'0"	B1@1.00	Ea	299.00	34.10	333.10
3'0" x 4'9"	B1@1.00	Ea	328.00	34.10	362.10
Screens for vinyl-clad wood windows. By window nominal size.					
2'0" x 3'0"	BC@.050	Ea	27.90	1.88	29.78
2'4" x 3'0"	BC@.050	Ea	30.70	1.88	32.58
2'4" x 3'6"	BC@.050	Ea	34.00	1.88	35.88
2'4" x 4'0"	BC@.050	Ea	35.20	1.88	37.08
2'4" x 4'6"	BC@.050	Ea	38.40	1.88	40.28
2'4" x 4'9"	BC@.050	Ea	39.70	1.88	41.58
2'8" x 3'0"	BC@.050	Ea	30.30	1.88	32.18
2'8" x 3'6"	BC@.050	Ea	35.00	1.88	36.88
2'8" x 4'0"	BC@.050	Ea	38.50	1.88	40.38
2'8" x 4'6"	BC@.050	Ea	39.80	1.88	41.68
2'8" x 4'9"	BC@.050	Ea	41.00	1.88	42.88
3'0" x 3'6"	BC@.050	Ea	35.10	1.88	36.98
3'0" x 4'0"	BC@.050	Ea	39.90	1.88	41.78
3'0" x 4'6"	BC@.050	Ea	42.70	1.88	44.58
3'0" x 4'9"	BC@.050	Ea	42.80	1.88	44.68
Vinyl-clad insulating glass wood awning windows. Prefinished pine interior. White vinyl exterior. Add the cost of screens. By nominal (opening) size, width × height.					
2'1" x 2'0"	BC@.500	Ea	261.00	18.80	279.80
3'1" x 2'0"	BC@.500	Ea	313.00	18.80	331.80
4'1" x 2'0"	BC@.500	Ea	329.00	18.80	347.80
White vinyl-clad insulating glass wood casement windows, Andersen. Prefinished pine interior. White vinyl exterior. Tilt sash. With nailing flange for new construction. By nominal (opening) size, width × height. Add the cost of screens. Hinge operation as viewed from the exterior.					
2'1" x 3'0", right hinge	BC@.500	Ea	304.00	18.80	322.80
2'1" x 3'0", left hinge	BC@.500	Ea	304.00	18.80	322.80
2'1" x 3'6", right hinge	BC@.500	Ea	343.00	18.80	361.80
2'1" x 3'6", left hinge	BC@.500	Ea	348.00	18.80	366.80
2'1" x 4'0", right hinge	BC@.500	Ea	362.00	18.80	380.80
2'1" x 4'0", left hinge	BC@.500	Ea	355.00	18.80	373.80

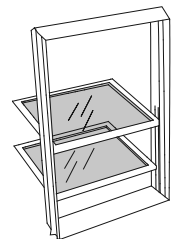

Windows

	Craft@Hrs	Unit	Material	Labor	Total
2'1" x 5'0", right hinge	B1@1.00	Ea	403.00	34.10	437.10
2'1" x 5'0", left hinge	B1@1.00	Ea	403.00	34.10	437.10
4'1" x 3'0", left and right hinge	B1@1.00	Ea	450.00	34.10	484.10
4'1" x 3'5", left and right hinge	B1@1.00	Ea	614.00	34.10	648.10
4'1" x 4'0", left and right hinge	B1@1.00	Ea	750.00	34.10	784.10
2'1" x 3'6", right hinge, egress	BC@.500	Ea	667.00	18.80	685.80
2'1" x 3'6", left hinge, egress	BC@.500	Ea	348.00	18.80	366.80
2'1" x 4'0", right hinge, egress	BC@.500	Ea	391.00	18.80	409.80
3'5" x 3'5", left hinge, egress	B1@1.00	Ea	679.00	34.10	713.10

Vinyl-clad insulating glass wood casement windows. Vinyl exterior. Unfinished wood interior. With hardware. Add the cost of grilles and screens. By nominal size, width × height.

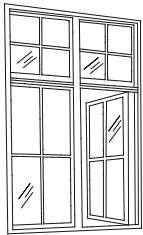

2'1" x 3'6", single opening, egress	BC@.500	Ea	309.00	18.80	327.80
2'1" x 4'0", single opening, egress	BC@.500	Ea	393.00	18.80	411.80
3'5" x 3'5", single opening	BC@.500	Ea	548.00	18.80	566.80
4'1" x 3'0", double opening	B1@1.50	Ea	572.00	51.20	623.20
4'1" x 3'5", double opening	B1@1.50	Ea	614.00	51.20	665.20
4'1" x 4'0", double opening	B1@1.50	Ea	707.00	51.20	758.20

Vinyl-clad insulating glass wood basement windows. Prefinished pine interior. White vinyl exterior. Tilt sash. With nailing flange for new construction. By nominal (opening) size, width × height. With screen.

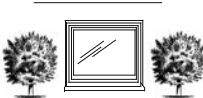

2'8" x 1'3"	BC@.500	Ea	116.00	18.80	134.80
2'8" x 1'7"	BC@.500	Ea	131.00	18.80	149.80
2'8" x 2'0"	BC@.500	Ea	146.00	18.80	164.80

Aluminum single-hung vertical sliding windows. Removable sash. Dual sash weatherstripping. Includes screen. By nominal (opening) size, width × height. With nailing flange for new construction.

Mill finish, single glazed

2'0" x 3'0"	BC@.500	Ea	94.50	18.80	113.30
2'8" x 3'0"	BC@.500	Ea	107.00	18.80	125.80
2'8" x 4'4"	BC@.500	Ea	131.00	18.80	149.80
2'8" x 5'0"	BC@.500	Ea	145.00	18.80	163.80
3'0" x 3'0"	BC@.500	Ea	110.00	18.80	128.80
3'0" x 4'0"	BC@.500	Ea	130.00	18.80	148.80
3'0" x 4'4"	BC@.500	Ea	130.00	18.80	148.80
3'0" x 5'0"	BC@.500	Ea	150.00	18.80	168.80

White finish, insulated glass, with grid

2'0" x 3'0"	BC@.500	Ea	115.00	18.80	133.80
2'8" x 3'0"	BC@.500	Ea	130.00	18.80	148.80
2'8" x 4'4"	BC@.500	Ea	160.00	18.80	178.80
2'8" x 5'0"	BC@.500	Ea	177.00	18.80	195.80
3'0" x 3'0"	BC@.500	Ea	101.00	18.80	119.80
3'0" x 4'0"	B1@1.00	Ea	160.00	34.10	194.10
3'0" x 4'4"	B1@1.00	Ea	170.00	34.10	204.10
3'0" x 5'0"	B1@1.50	Ea	180.00	51.20	231.20
3'0" x 6'0"	B1@1.50	Ea	207.00	51.20	258.20

Solar bronze insulating glass

2'0" x 2'0"	BC@.500	Ea	136.00	18.80	154.80
2'0" x 3'0"	BC@.500	Ea	136.00	18.80	154.80
2'0" x 4'0"	BC@.500	Ea	162.00	18.80	180.80
3'0" x 3'0"	BC@.500	Ea	174.00	18.80	192.80
3'0" x 4'0"	B1@1.00	Ea	235.00	34.10	269.10

Impact-resistant aluminum single hung windows. Glass bonded with clear polyvinyl. With screen.

26" x 38", obscure	BC@.500	Ea	304.00	18.80	322.80
37" x 26"	BC@.500	Ea	340.00	18.80	358.80
37" x 50"	B1@1.00	Ea	443.00	34.10	477.10

Windows

	Craft@Hrs	Unit	Material	Labor	Total
37" x 63"	B1@1.50	Ea	529.00	51.20	580.20
53" x 38"	B1@1.50	Ea	500.00	51.20	551.20
53" x 50"	B1@1.50	Ea	623.00	51.20	674.20
Aluminum horizontal sliding windows. Right sash is operable when viewed from the interior. With screen, 7/8" nailing fin setback for 3-coat stucco or wood siding. By nominal (opening) size, width × height. Obscure glass is usually available in smaller (1' and 2') windows at no additional cost.					
Mill finish windows, single glazed					
2'0" x 2'0"	BC@.500	Ea	52.00	18.80	70.80
3'0" x 2'0"	BC@.500	Ea	59.10	18.80	77.90
3'0" x 3'0"	BC@.500	Ea	74.00	18.80	92.80
3'0" x 4'0"	B1@1.00	Ea	89.60	34.10	123.70
4'0" x 3'0"	B1@1.00	Ea	89.60	34.10	123.70
4'0" x 4'0"	BC@1.50	Ea	105.00	56.50	161.50
6'0" x 3'0"	BC@1.50	Ea	119.00	56.50	175.50
6'0" x 4'0"	BC@1.50	Ea	136.00	56.50	192.50
White finish windows, insulating glass					
2'0" x 2'0"	BC@.500	Ea	74.00	18.80	92.80
3'0" x 1'0"	BC@.500	Ea	86.80	18.80	105.60
3'0" x 2'0"	BC@.500	Ea	96.10	18.80	114.90
3'0" x 3'0"	BC@.500	Ea	119.00	18.80	137.80
3'0" x 4'0"	B1@1.00	Ea	145.00	34.10	179.10
4'0" x 3'0"	B1@1.00	Ea	145.00	34.10	179.10
4'0" x 4'0"	BC@1.50	Ea	151.00	56.50	207.50
White finish windows, insulating glass, with grid					
3'0" x 3'0"	BC@.500	Ea	153.00	18.80	171.80
3'0" x 4'0"	B1@1.00	Ea	186.00	34.10	220.10
4'0" x 3'0"	B1@1.00	Ea	185.00	34.10	219.10
4'0" x 4'0"	B1@1.50	Ea	215.00	51.20	266.20
5'0" x 3'0"	B1@1.50	Ea	214.00	51.20	265.20
5'0" x 4'0"	B1@1.50	Ea	228.00	51.20	279.20
6'0" x 3'0"	B1@1.50	Ea	246.00	51.20	297.20
6'0" x 4'0"	B1@1.50	Ea	262.00	51.20	313.20
Solar bronze insulating glass windows					
2'0" x 2'0"	BC@.500	Ea	99.10	18.80	117.90
3'0" x 3'0"	BC@.500	Ea	158.00	18.80	176.80
3'0" x 4'0"	B1@1.00	Ea	166.00	34.10	200.10
4'0" x 3'0"	B1@1.00	Ea	166.00	34.10	200.10
4'0" x 4'0"	B1@1.50	Ea	197.00	51.20	248.20
5'0" x 4'0"	B1@1.50	Ea	219.00	51.20	270.20
6'0" x 4'0"	B1@1.50	Ea	255.00	51.20	306.20
White finish windows, insulating low-E glass					
3'0" x 3'0"	BC@.500	Ea	153.00	18.80	171.80
3'0" x 4'0"	B1@1.00	Ea	193.00	34.10	227.10
4'0" x 3'0"	B1@1.00	Ea	185.00	34.10	219.10
4'0" x 4'0"	B1@1.50	Ea	206.00	51.20	257.20
5'0" x 4'0"	B1@1.50	Ea	228.00	51.20	279.20
6'0" x 4'0"	BC@1.50	Ea	276.00	56.50	332.50
Aluminum single glazed awning windows. With hardware and screen. Painted powder polyurethane finish. Solar bronze glass. Opening (nominal) sizes, width × height.					
24" x 20-1/8", one lite high	BC@.500	Ea	67.10	18.80	85.90
24" x 28-3/4", two lites high	BC@.500	Ea	96.10	18.80	114.90
24" x 37-3/8", three lites high	B1@1.00	Ea	101.00	34.10	135.10

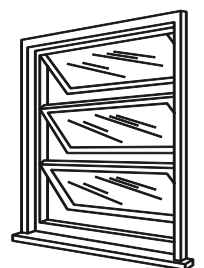
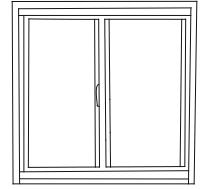

Windows

	Craft@Hrs	Unit	Material	Labor	Total
24" x 46", four lites high	B1@1.00	Ea	101.00	34.10	135.10
24" x 54-5/8", five lites high	B1@1.50	Ea	129.00	51.20	180.20
24" x 63-1/4", six lites high	B1@1.50	Ea	136.00	51.20	187.20
30" x 20-1/8", one lite high	BC@.500	Ea	82.20	18.80	101.00
30" x 28-3/4", two lites high	BC@.500	Ea	94.20	18.80	113.00
30" x 37-3/8", three lites high	B1@1.00	Ea	110.00	34.10	144.10
30" x 46", four lites high	B1@1.00	Ea	122.00	34.10	156.10
30" x 54-5/8", five lites high	B1@1.50	Ea	144.00	51.20	195.20
30" x 63-1/4", six lites high	B1@1.50	Ea	166.00	51.20	217.20
36" x 20-1/8", one lite high	BC@.500	Ea	82.00	18.80	100.80
36" x 28-3/4", two lites high	BC@.500	Ea	105.00	18.80	123.80
36" x 37-3/8", three lites high	B1@1.00	Ea	112.00	34.10	146.10
36" x 46", four lites high	B1@1.00	Ea	129.00	34.10	163.10
36" x 54-5/8", five lites high	B1@1.50	Ea	156.00	51.20	207.20
36" x 63-1/4", six lites high	B1@1.50	Ea	225.00	51.20	276.20

Double-hung insulating glass wood windows. Treated western pine. Natural wood interior. 4-9/16" jamb width. 5/8" insulating glass. Weatherstripped. Tilt-in, removable sash. With hardware. Nominal sizes, width × height. With screen.

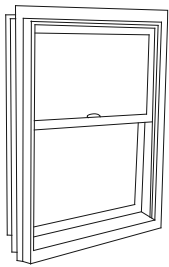

2'0" x 3'2"	BC@.500	Ea	196.00	18.80	214.80
2'4" x 3'2"	BC@.500	Ea	216.00	18.80	234.80
2'4" x 4'6"	BC@.500	Ea	246.00	18.80	264.80
2'8" x 3'2"	BC@.500	Ea	231.00	18.80	249.80
2'8" x 3'10"	BC@.500	Ea	238.00	18.80	256.80
2'8" x 4'6"	B1@1.00	Ea	258.00	34.10	292.10
2'8" x 5'2"	B1@1.00	Ea	270.00	34.10	304.10
2'8" x 6'2"	B1@1.00	Ea	299.00	34.10	333.10
3'0" x 3'2"	BC@.500	Ea	238.00	18.80	256.80
3'0" x 3'10"	B1@1.00	Ea	235.00	34.10	269.10
3'0" x 4'6"	B1@1.00	Ea	267.00	34.10	301.10
3'0" x 5'2"	B1@1.00	Ea	278.00	34.10	312.10
3'0" x 6'2"	B1@1.00	Ea	336.00	34.10	370.10
2'8" x 4'6", twin	B1@1.00	Ea	477.00	34.10	511.10
3'0" x 4'6", twin	B1@1.00	Ea	555.00	34.10	589.10

Fixed octagon wood windows. Stock units for new construction.

24", 9-lite beveled glass	BC@1.50	Ea	191.00	56.50	247.50
24", insulating glass	BC@1.50	Ea	166.00	56.50	222.50
24", beveled glass	BC@1.50	Ea	133.00	56.50	189.50
24", single glazed	BC@1.50	Ea	129.00	56.50	185.50
24", venting insulating glass	BC@1.50	Ea	221.00	56.50	277.50

Angle bay windows. Fixed center lite and two double-hung flankers. 30-degree angle. Pine with aluminum cladding insulating glass. With screen. White or bronze finish. 4-9/16" wall thickness. Opening (nominal) sizes, width × height. Add the cost of interior trim and installing or framing the bay window roof. See the figures that follow.

6'4" x 4'8"	B1@4.00	Ea	2,280.00	136.00	2,416.00
7'2" x 4'8"	B1@4.00	Ea	2,290.00	136.00	2,426.00
7'10" x 4'8"	B1@4.50	Ea	2,470.00	153.00	2,623.00
8'6" x 4'8"	B1@4.50	Ea	2,840.00	153.00	2,993.00
8'10" x 4'8"	B1@4.50	Ea	3,000.00	153.00	3,153.00
9'2" x 4'8"	B1@5.00	Ea	2,950.00	171.00	3,121.00
9'10" x 4'8"	B1@5.00	Ea	3,100.00	171.00	3,271.00
Add for 45 degree angle windows	—	Ea	116.00	—	116.00
Add for roof framing kit	—	Ea	356.00	—	356.00

Windows

	Craft@Hrs	Unit	Material	Labor	Total
Bay window roof cover. Architectural copper roof system for standard angle bay windows. Includes hardware. Stock units for new construction.					
Up to 48" width	SW@.500	Ea	1,590.00	21.30	1,611.30
49" to 60" width	SW@.500	Ea	1,840.00	21.30	1,861.30
61" to 72" width	SW@.600	Ea	2,010.00	25.50	2,035.50
73" to 84" width	SW@.600	Ea	2,240.00	25.50	2,265.50
85" to 96" width	SW@.600	Ea	2,470.00	25.50	2,495.50
97" to 108" width	SW@.700	Ea	2,690.00	29.80	2,719.80
109" to 120" width	SW@.700	Ea	2,940.00	29.80	2,969.80
121" to 132" width	SW@.800	Ea	3,350.00	34.00	3,384.00
133" to 144" width	SW@.800	Ea	3,560.00	34.00	3,594.00
145" to 156" width	SW@1.00	Ea	3,810.00	42.50	3,852.50
157" to 168" width	SW@1.00	Ea	4,020.00	42.50	4,062.50
Add for aged copper, brass or aluminum finish	—	%	20.0	—	—
Add for 24" to 26" projection	—	%	10.0	—	—
Add for 26" to 28" projection	—	%	15.0	—	—
Add for 28" to 30" projection	—	%	20.0	—	—
Add for brick soffit kit	—	%	45.0	—	—
Add for 90-degree bays	—	Ea	87.60	—	87.60
Casement bow windows. Insulating glass, assembled, with screens, weatherstripped, unfinished pine, 16" projection, 22" x 56" lites, 4-7/16" jambs. Add the cost of interior trim and installing or framing the bow window roof. Stock units for new construction. Generally a roof kit is required for projections of 12" or more. See the figures that follow.					
8'1" wide x 4'8" (4 lites, 2 venting)	B1@4.75	Ea	2,410.00	162.00	2,572.00
8'1" wide x 5'4" (4 lites, 2 venting)	B1@4.75	Ea	2,610.00	162.00	2,772.00
8'1" wide x 6'0" (4 lites, 2 venting)	B1@4.75	Ea	2,820.00	162.00	2,982.00
10' wide x 4'8" (5 lites, 2 venting)	B1@4.75	Ea	2,930.00	162.00	3,092.00
10' wide x 5'4" (5 lites, 2 venting)	B1@4.75	Ea	3,160.00	162.00	3,322.00
10' wide x 6'0" (5 lites, 2 venting)	B1@4.75	Ea	3,480.00	162.00	3,642.00
Add for roof framing kit, 5 lites	—	Ea	316.00	—	316.00
Add for interior and exterior trim					
3, 4 or 5 lites	B1@2.00	Set	99.40	68.20	167.60
Bow or bay window roof framed on site. 1/2" plywood sheathing, fiberglass batt insulation, fascia board, cove molding, roof flashing, 15-pound felt, 240-pound seal-tab asphalt shingles, and cleanup.					
Up to 120" width	B1@3.50	Ea	146.00	119.00	265.00
Add per linear foot of width over 10'	B1@.350	LF	14.60	11.90	26.50
Basement storm windows. White aluminum frame with removable Plexiglass window. Clips on over aluminum or wood basement window. Screen included. Nominal window sizes, width x height.					
32" x 14"	BC@.420	Ea	32.30	15.80	48.10
32" x 18"	BC@.420	Ea	32.30	15.80	48.10
32" x 22"	BC@.420	Ea	30.90	15.80	46.70
Aluminum storm windows. Removable glass inserts. Removable screen. Double track. Includes weatherstripping. Adaptable to aluminum single-hung windows.					
24" x 39", mill finish	BC@.420	Ea	46.70	15.80	62.50
24" x 39", white finish	BC@.420	Ea	52.20	15.80	68.00
24" x 55", mill finish	BC@.420	Ea	68.50	15.80	84.30
24" x 55", white finish	BC@.420	Ea	68.50	15.80	84.30
28" x 39", mill finish	BC@.420	Ea	53.20	15.80	69.00
28" x 39", white finish	BC@.420	Ea	56.20	15.80	72.00
28" x 47", white finish	BC@.420	Ea	63.90	15.80	79.70
28" x 55", mill finish	BC@.420	Ea	62.30	15.80	78.10
28" x 55", white finish	BC@.420	Ea	70.00	15.80	85.80
32" x 39", mill finish	BC@.420	Ea	54.00	15.80	69.80

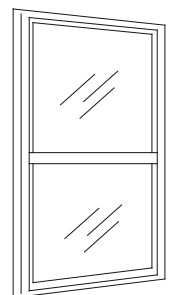
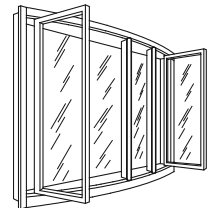

Window Wells

	Craft@Hrs	Unit	Material	Labor	Total
32" x 39", white finish	BC@.420	Ea	60.50	15.80	76.30
32" x 47", white finish	BC@.420	Ea	73.50	15.80	89.30
32" x 55", mill finish	BC@.420	Ea	64.10	15.80	79.90
32" x 55", white finish	BC@.420	Ea	68.50	15.80	84.30
32" x 63", mill finish	BC@.420	Ea	76.40	15.80	92.20
32" x 63", white finish	BC@.420	Ea	76.40	15.80	92.20
32" x 75", white finish	BC@.420	Ea	91.90	15.80	107.70
36" x 39", mill finish	BC@.420	Ea	54.80	15.80	70.60
36" x 39", white finish	BC@.420	Ea	64.10	15.80	79.90
36" x 55", mill finish	BC@.420	Ea	65.50	15.80	81.30
36" x 55", white finish	BC@.420	Ea	73.00	15.80	88.80
36" x 63", mill finish	BC@.420	Ea	75.00	15.80	90.80
36" x 63", white finish	BC@.420	Ea	81.70	15.80	97.50

Window wells ScapeWel egress window, meets code requirements for basement escape window. Snaps into place on site. For new construction and remodeling, attaches directly to foundation. Bilco.

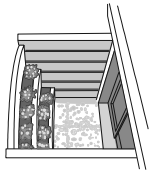

Model 4048-42, 42" x 48" two tier	B1@1.50	Ea	1,070.00	51.20	1,121.20
4042C polycarbonate window well cover					
Fits Model 4048-42	—	Ea	446.00	—	446.00

Model 4048-54, 54" x 48" two tier	B1@1.50	Ea	1,150.00	51.20	1,201.20
4054C polycarbonate window well cover					
Fits Model 4048-54	—	Ea	496.00	—	496.00

Model 4048-66, 66" x 48" two tier	B1@1.50	Ea	1,230.00	51.20	1,281.20
4066C polycarbonate window well cover					
Fits Model 4048-66	—	Ea	530.00	—	530.00

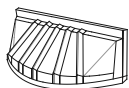

Model 4862-42, 42" x 62" three tier	B1@1.50	Ea	1,310.00	51.20	1,361.20
4842C polycarbonate window well cover					
Fits Model 4862-42	—	Ea	479.00	—	479.00

Model 4862-54, 54" x 62" three tier	B1@1.50	Ea	1,360.00	51.20	1,411.20
4854C polycarbonate window well cover					
Fits Model 4862-54	—	Ea	496.00	—	496.00

Model 4862-66, 66" x 62" three tier	B1@1.50	Ea	1,590.00	51.20	1,641.20
4866C polycarbonate window well cover					
Fits Model 4862-66	—	Ea	533.00	—	533.00

Single Family Home Costs

Use the costs below to check your estimates and to verify bids submitted by subcontractors. These costs are based on a 1,600 square foot home (as described on page 307) built during the third quarter of 2021 at a forecasted cost of \$140.31 per square foot. Figures in the column “% of Total” are the same as those listed in the Residential Rule of Thumb Construction Costs on page 307. These are averages and will vary widely with the type and quality of construction.

Item	Total manpower required	% of Total	Unit	\$ Material	\$ Labor	\$ Equipment	Total \$ per SF	Total \$ 1600 SF
Excavation	3 men 2 days	1.2%	SF	—	\$1.26	\$0.42	\$1.68	\$2,688
Foundation, slab, piers	3 men 4 days	3.7%	SF	\$2.08	2.60	0.51	5.19	8,304
Flatwork (drive and walk)	3 men 3 days	2.4%	SF	1.35	1.69	0.33	3.37	5,392
Brick hearth & veneer	2 men 1 day	0.7%	SF	0.39	0.49	0.10	0.98	1,568
Rough hardware		0.6%	SF	0.34	0.42	0.08	0.84	1,344
Finish hardware		0.2%	SF	0.17	0.11	—	0.28	448
Rough lumber		6.4%	SF	8.98	—	—	8.98	14,368
Finish lumber		0.5%	SF	0.70	—	—	0.70	1,120
Rough carpentry labor	2 men 20 days	8.9%	SF	—	12.49	—	12.49	19,984
Finish carpentry labor	1 man 7 days	1.7%	SF	—	2.39	—	2.39	3,824
Countertops	1 man 2 days	1.5%	SF	1.26	0.84	—	2.10	3,360
Cabinets	2 men 2 days	3.7%	SF	4.15	1.04	—	5.19	8,304
Insulation (R19 ceiling)	1 man 3 days	2.3%	SF	2.10	1.13	—	3.23	5,168
Roofing	4 men 3 days	5.5%	SF	4.63	3.09	—	7.72	12,352
Painting	2 men 3 days	3.6%	SF	1.77	3.28	—	5.05	8,080
Shower & tub enclosure	1 man 1 day	0.5%	SF	0.42	0.28	—	0.70	1,120
Prefabricated fireplace	1 man 1 day	0.9%	SF	0.95	0.25	0.06	1.26	2,016
Bath accessories	1 man 1 day	0.7%	SF	0.65	0.33	—	0.98	1,568
Built-in appliances	1 man 1 day	1.6%	SF	2.02	0.22	—	2.24	3,584
Heating and ducting	2 men 5 days	2.9%	SF	1.63	2.44	—	4.07	6,512
Plmbg & sewer connections	3 men 5 days	7.3%	SF	4.10	5.12	1.02	10.24	16,384
Doors	2 men 2 days	1.9%	SF	1.74	0.93	—	2.67	4,272
Garage door	1 man 1 day	0.4%	SF	0.42	0.14	—	0.56	896
Alum windows/slidg drs	1 man 2 days	1.2%	SF	1.01	0.67	—	1.68	2,688
Exterior stucco	3 men 3 days	6.4%	SF	5.84	2.69	0.45	8.98	14,368
Gypsum wallboard	2 men 6 days	4.7%	SF	2.95	3.64	—	6.59	10,544
Resilient flooring	1 man 1 day	2.0%	SF	1.32	1.49	—	2.81	4,496
Carpeting	2 men 1 day	2.4%	SF	2.70	0.67	—	3.37	5,392
Wiring (Romex)	1 man 10 days	3.2%	SF	1.80	2.69	—	4.49	7,184
Lighting fixtures		1.2%	SF	1.34	0.34	—	1.68	2,688
Subtotal, DIRECT JOB COSTS		80.2%		\$56.81	\$52.73	\$2.97	\$112.51	\$180,016
Amount above, as a percent of total direct costs				50.49%	46.87%	2.64%	100.00%	—
Indirect Costs		%	of Total	\$	\$	\$	Total \$	Total \$
			Unit	Material	Labor	Equipment	per SF	1600 SF
Insurance, payroll tax		4.8%	SF	\$6.73	—	—	\$6.73	\$10,768
Plans & specs		0.4%	SF	0.56	—	—	0.56	896
Permits & utilities		1.7%	SF	2.39	—	—	2.39	3,824
Final cleanup		0.4%	SF	—	0.56	—	0.56	896
Subtotal, INDIRECT JOB COSTS		7.3%		\$9.68	\$0.56	—	\$10.24	16,384
Overhead & profit		12.5%	SF	\$17.56	—	—	\$17.56	\$28,096
Total all costs, rounded (based on 1600 SF)		100.0%	SF	\$84.05	\$53.29	\$2.97	\$140.31	\$224,496
Amount above, as a percent of total direct costs =				59.90%	37.98%	2.12%	100.00%	—

The “Manpower” column assumes work is done in phases. Elapsed time, from breaking ground to final cleanup, will be about 10 weeks, plus delays due to weather, shortages and schedule conflicts.

Construction Economics Division

Construction Cost Index for New Single Family Homes

Period	% of 1967 Cost	\$ per SF of Floor	Period	% of 1967 Cost	\$ per SF of Floor	Period	% of 1967 Cost	\$ per SF of Floor
2004			2010			2016		
1st quarter	557.54	78.01	1st quarter	712.93	99.75	1st quarter	833.78	116.66
2nd quarter	578.42	80.93	2nd quarter	726.72	101.68	2nd quarter	838.41	117.31
3rd quarter	587.05	82.10	3rd quarter	732.20	102.45	3rd quarter	837.71	117.98
4th quarter	611.14	85.51	4th quarter	735.44	102.90	4th quarter	840.98	118.44
2005			2011			2017		
1st quarter	608.70	85.17	1st quarter	744.17	104.12	1st quarter	848.78	119.54
2nd quarter	616.87	86.31	2nd quarter	751.04	104.94	2nd quarter	858.77	120.95
3rd quarter	621.21	87.18	3rd quarter	755.55	105.91	3rd quarter	865.06	121.83
4th quarter	631.35	88.34	4th quarter	757.83	106.66	4th quarter	868.41	122.30
2006			2012			2018		
1st quarter	641.63	89.77	1st quarter	762.28	106.66	1st quarter	876.46	123.44
2nd quarter	641.73	89.79	2nd quarter	767.30	107.37	2nd quarter	881.32	124.12
3rd quarter	644.78	89.87	3rd quarter	770.24	107.82	3rd quarter	894.46	125.97
4th quarter	655.91	91.77	4th quarter	773.50	108.23	4th quarter	901.95	127.03
2007			2013			2019		
1st quarter	656.08	91.80	1st quarter	778.13	108.87	1st quarter	904.05	127.32
2nd quarter	653.57	91.45	2nd quarter	781.69	109.37	2nd quarter	904.36	127.37
3rd quarter	655.00	91.67	3rd quarter	785.74	109.94	3rd quarter	907.56	127.82
4th quarter	658.00	92.07	4th quarter	788.05	110.26	4th quarter	913.09	128.60
2008			2014			2020		
1st quarter	665.00	93.04	1st quarter	792.90	110.94	1st quarter	919.74	129.53
2nd quarter	677.06	94.73	2nd quarter	796.73	111.48	2nd quarter	922.73	129.95
3rd quarter	699.06	95.17	3rd quarter	805.49	112.70	3rd quarter	926.32	130.46
4th quarter	720.45	100.80	4th quarter	813.67	113.85	4th quarter	936.96	131.96
2009			2015			2021		
1st quarter	707.78	99.03	1st quarter	814.22	113.92	1st quarter	956.17	134.66
2nd quarter	704.72	98.60	2nd quarter	815.65	114.12	2nd quarter	978.77	137.85
3rd quarter	704.69	98.59	3rd quarter	820.60	114.82	3rd quarter	996.25	140.31
4th quarter	704.85	98.62	4th quarter	823.08	115.16	4th quarter		

The figures under the column "\$ per SF of Floor" show construction costs for building a good quality home in a suburban area under competitive conditions in each calendar quarter since 2004. This home is described below under the section "Residential Rule of Thumb." These costs include the builder's overhead and profit and a 450 square foot garage but no basement. The cost of a finished basement per square foot will be approximately 30% of the square foot cost of living area. If the garage area is more than 450 square feet, use 50% of the living area cost to adjust for the larger or smaller garage. To find the total construction cost of the home, multiply the living area (excluding the garage) by the cost in the column "\$ per SF of Floor."

Deduct for rural areas	5.0%
Add for 1,800 SF house (better quality)	4.0
Add for 2,000 SF house (better quality)	3.0
Deduct for over 2,400 SF house	3.0
Add for split level house	3.0
Add for 3-story house	10.0
Add for masonry construction	9.0

Construction costs are higher in some cities and lower in others. Square foot costs listed in the table above are national averages. To modify these costs to your job site, apply the appropriate area modification factor from pages 12 through 15 of this manual. But note that area modifications on pages 12 through 15 are based on recent construction and may not apply to work that was completed many years ago.

Residential Rule of Thumb

Construction Costs

The following figures are percentages of total construction cost for a standard quality single family residence: 1,600 square foot single story, 3-bedroom, 1¾ bath home plus attached two car (450 SF) garage. Costs assume a conventional floor, stucco exterior, wallboard interior, shingle roof, single fireplace, forced air heat, PVC water supply and drain lines, range with double oven, disposer, dishwasher and 900 SF of concrete flatwork.

Item	Percent	Item	Percent	Item	Percent	Item	Percent	Item	Percent
Excavation	1.2	Finish lumber	.5	Painting	3.6	Doors	1.9	Wiring (Romex)	3.2
Flatwork (drive & walk)	2.4	Rough carpentry labor	8.9	Shower & tub enclosure	.5	Garage door	.4	Lighting fixtures	1.2
Foundation, slab, piers	3.7	Finish carpentry labor	1.7	Prefabricated fireplace	.9	Alum. windows, door	1.2	Insurance, tax	4.8
Brick hearth & veneer	.7	Countertops	1.5	Bath accessories	.7	Exterior stucco	6.4	Plans and specs	.4
Rough hardware	.6	Cabinets	3.7	Built-in appliances	1.6	Gypsum wallboard	4.7	Permits & utilities	1.7
Finish hardware	.2	Insulation (R19 ceiling)	2.3	Heating and ducting	2.9	Resilient flooring	2.0	Final cleanup	.4
Rough lumber	6.4	Roofing	5.5	Plumb. & sewer conn.	7.3	Carpeting	2.4	Overhead & profit	12.5

Industrial and Commercial Division Contents

A complete index begins on page 640

01 General Requirements	310-332	Ecclesiastical equipment.....	460
Markup & overhead.....	310	Theater & stage equipment.....	462
Equipment rental rates.....	320	Athletic equipment.....	464
02 Existing Conditions	332-338	12 Furnishings	470-475
Site clearing and demolition.....	332	Window treatment.....	471
Building demolition.....	334	Cabinets.....	472
03 Concrete	338-371	Seating and benches.....	474
Excavation for concrete.....	338	13 Special Construction	475-488
Concrete formwork.....	339	Access for the disabled.....	476
Reinforcing steel.....	346	Pre-fab steel buildings.....	480
Ready-mix concrete.....	350	14 Conveying Equipment	488-491
Concrete assemblies.....	352	Elevators.....	489
Concrete finishing.....	356	Hoists and cranes.....	490
Precast and tilt-up concrete.....	357	21 Fire Suppression	491-493
Foundations.....	361	Sprinkler systems.....	491
04 Masonry	371-382	Hoses and extinguishers.....	493
Reinforcing and flashing.....	372	22 Plumbing	494-535
Brick and block walls.....	373	Black steel pipe and fittings.....	494
Glass block.....	380	Copper pipe & fittings.....	503
Pavers.....	382	PVC pipe and fittings.....	506
05 Metals	383-389	Copper DWV pipe & fittings.....	512
Structural steel.....	383	ABS DWV pipe & fittings.....	512
Steel floor and roof decking.....	384	Hangers and supports.....	516
Stairways.....	385	Valves, pumps, gauges.....	519
06 Wood and Composites	389-397	Cleanouts and drains.....	525
Framing carpentry.....	389	Plumbing equipment.....	526
Panelized roof & wall systems.....	392	Sump pumps.....	528
Laminated glued beams.....	396	Rough-in assemblies.....	530
07 Thermal & Moisture Protection	397-412	23 HVAC	535-541
Damproofing.....	397	Gas fired heaters.....	535
Thermal insulation.....	398	Hydronic & steam heating.....	537
Roof insulation.....	399	26 Electrical	541-588
Membrane roofing.....	401	Light and power circuits.....	542
Flashing & sheet metal.....	403	Rigid steel conduit.....	543
Gutters & downspouts.....	404	EMT conduit.....	544
Fireproofing.....	407	PVC conduit.....	547
Sealants & caulking.....	410	Conduit hangers & supports.....	554
08 Openings	412-423	Wire and cable.....	557
Metal doors.....	412	Boxes, receptacles, switches.....	561
Windows.....	419	Switchboards.....	569
Hardware.....	420	Circuit breakers.....	574
09 Finishes	423-440	Lighting.....	582
Gypsum wallboard.....	423	27 Communications	589-594
Plastering.....	426	Security & alarm systems.....	589
Metal framed shaft walls.....	427	Computer network cable.....	592
Ceramic tile.....	427	31 Earthwork	594-609
Ceilings and flooring.....	429	Site grading.....	596
Wall coverings.....	434	Trench excavation and backfill.....	597
Surface prep and painting.....	435	Slope protection.....	604
10 Specialties	440-449	Shoring, bulkheads, piles.....	605
Identifying devices.....	441	32 Exterior Improvements	609-626
Compartments and cubicles.....	442	Paving and curbs.....	609
Partitions.....	443	Fencing and gates.....	617
Toilet and bath accessories.....	445	Irrigation systems.....	618
Postal specialties.....	447	Planting & landscaping.....	622
Flagpoles.....	448	33 Utilities	626-639
11 Equipment	449-470	Pressure water pipe.....	628
Service station equipment.....	449	Drain pipe.....	630
Bank equipment.....	452	Catch basins & manholes.....	635
Food service equipment.....	453		
Educational equipment.....	458		

Industrial and Commercial Division

Hourly Labor Costs

The hourly labor costs shown in the column headed "Hourly Cost" have been used to compute the manhour costs for the crews on pages 8 and 9 and the costs in the "Labor" column on pages 310 to 639 of this book. All figures are in U.S. dollars per hour.

"Hourly Wage and Benefits" includes the wage, welfare, pension, vacation, apprentice and other mandatory contributions. The "Typical Employer's Burden" is the cost to the contractor for Unemployment Insurance (FUTA), Social Security (FICA) and Medicare, state unemployment insurance, workers' compensation insurance and liability insurance. Tax and insurance expense included in these labor-hour costs are itemized in the sections beginning on pages 185 and 285.

These hourly labor costs will apply within a few percent on many jobs. But wages may be much higher or lower on the job you are estimating. If the hourly cost on this page is not accurate for your jobs, use the labor cost adjustment procedure on page 11.

If your hourly labor cost is not known and can't be estimated, use both labor and material figures in this book without adjustment. When all material and labor costs have been compiled, multiply the total by the appropriate figure in the area modification table on pages 12 through 15.

Craft	Hourly Wage and Benefits (\$)	Typical Employer Burden (%)	Employer's Burden Per Hour (\$)	Hourly Cost (\$)
Air Tool Operator	32.34	37.57%	12.15	44.49
Asbestos Worker	44.30	38.74%	17.16	61.46
Boilermaker	45.07	38.10%	17.17	62.24
Bricklayer	40.83	33.60%	13.72	54.55
Bricklayer Tender	31.29	33.62%	10.52	41.81
Building Laborer	31.12	33.87%	10.54	41.66
Carpenter	40.34	32.70%	13.19	53.53
Cement Mason	38.40	35.00%	13.44	51.84
Crane Operator	42.17	37.54%	15.83	58.00
Drywall Installer	40.36	30.85%	12.45	52.81
Electrician	46.95	29.95%	14.06	61.01
Elevator Constructor	44.92	28.65%	12.87	57.79
Floor Layer	38.37	35.18%	13.50	51.87
Glazier	42.31	32.50%	13.75	56.06
Iron Worker (Structural)	44.85	48.58%	21.79	66.64
Lather	36.52	32.58%	11.90	48.42
Marble Setter	41.23	32.69%	13.48	54.71
Millwright	41.03	32.56%	13.36	54.39
Mosaic & Terrazzo Worker	38.89	32.66%	12.70	51.59
Painter	40.55	32.63%	13.23	53.78
Pile Driver	41.92	37.12%	15.56	57.48
Pipefitter	47.42	33.02%	15.66	63.08
Plasterer	41.08	34.96%	14.36	55.44
Plasterer Helper	33.89	34.94%	11.84	45.73
Plumber	48.23	33.03%	15.93	64.16
Reinforcing Ironworker	47.00	39.89%	18.75	65.75
Roofer	36.03	38.58%	13.90	49.93
Sheet Metal Worker	46.41	32.00%	14.85	61.26
Sprinkler Fitter	49.71	31.70%	15.76	65.47
Tractor Operator	42.01	37.56%	15.78	57.79
Truck Driver	33.93	37.58%	12.75	46.68

01 General Requirements

General Contractor's Markup Costs in this manual do not include the general contractor's markup. Costs in sections identified as *subcontract* are representative of prices quoted by subcontractors and include the subcontractor's markup. See pages 3 through 5 for more on subcontracted work and markup. Typical markup for general contractors handling commercial and industrial projects is shown at the bottom of this page. The two sections that follow, Indirect Overhead and Direct Overhead, give a more detailed breakdown.

Indirect Overhead (home office overhead)

This cost, usually estimated as a percentage, is calculated by dividing average annual indirect overhead costs by average annual receipts. Temporary increases or decreases in revenue usually won't affect indirect overhead expense as much as direct overhead expense.

The figures below show typical indirect overhead costs per \$1,000 of estimated project costs for a general contractor handling non-residential projects from \$1 to \$5 million. Indirect overhead costs vary widely but will be about 8% of gross for most profitable firms. Total indirect overhead cost (\$20.00 per \$1,000 for materials and \$60.00 per \$1,000 for labor) appears as 2.0% and 6.0% under Total General Contractor's Markup at the bottom of this page.

	Craft@Hrs	Unit	Material	Labor	Total
Rent, office supplies, utilities, equipment, advertising, etc.	—	M\$	20.00	—	20.00
Office salaries and professional fees	—	M\$	—	60.00	60.00
General Contractor's indirect overhead	—	M\$	20.00	60.00	80.00

Direct Overhead (job site overhead)

The figures below show typical direct overhead costs per \$1,000 of a project's total estimated costs for a general contractor handling non-residential projects from \$1 to \$5 million and require 6 to 12 months for completion. Use these figures for preliminary estimates and to check final bids. Add the cost of mobilization, watchmen, fencing, hoisting, permits, bonds, scaffolding and testing. Total direct overhead cost (\$14.30 per \$1,000 for materials and \$58.70 per \$1,000 for labor) appears as 1.4% and 5.9% under Total General Contractor's Markup at the bottom of this page. These costs can be expected to vary and will usually be lower on larger projects.

Job supervision	—	M\$	—	44.00	44.00
Truck and fuel for superintendent (\$450 per month)	—	M\$	4.50	—	4.50
Temporary power, light and heat (\$250 per month)	—	M\$	2.50	—	2.50
Temporary water (\$100 per month)	—	M\$	1.00	—	1.00
Cellphone (\$50 per month)	—	M\$.50	—	.50
Job site toilets (\$100 per month)	—	M\$	1.00	—	1.00
Job site office trailer 8' x 16' (\$150 per month)	—	M\$	1.50	—	1.50
Storage bin and tool shed 8' x 8' (\$80 per month)	—	M\$.80	—	.80
Job site cleanup & debris removal (\$300 per month)	—	M\$	—	3.00	3.00
Job signs & first aid equipment (\$50 per month)	—	M\$.50	—	.50
Small tools, supplies (\$200 per month)	—	M\$	2.00	—	2.00
Taxes and insurance on wages (typical)	—	M\$	—	11.70	11.70
Total General Contractor's direct overhead	—	M\$	14.30	58.70	73.00

Total General Contractor's Markup Typical costs for commercial and industrial projects.

Indirect overhead (home office overhead)	—	%	2.0	6.0	8.0
Direct overhead (job site overhead)	—	%	1.4	5.9	7.3
Contingency (allowance for unknown conditions)	—	%	—	—	2.0
Profit (varies widely, mid-range shown)	—	%	—	—	7.5
Total General Contractor's markup	—	%	—	—	24.8

01 General Requirements

Craft@Hrs Unit Material Labor Total

Project Financing Construction loans are usually made for a term of up to 18 months. The maximum loan will be based on the value of the land and building when completed. Typically, this maximum is 75% for commercial, industrial and apartment buildings and 77.5% for tract housing.

The initial loan disbursement will be about 50% of the land cost. Periodic disbursements are based on the percentage of completion as verified by voucher or inspection. The last 20% of loan proceeds is disbursed when an occupancy permit is issued. Fund control fees cover the cost of monitoring disbursements. Typical loan fees, loan rates and fund control fees are listed below.

Loan origination fee, based on amount of loan

Tracts	—	%	—	—	2.5
Apartments	—	%	—	—	2.0
Commercial, industrial buildings	—	%	—	—	3.0

Loan interest rate, prime rate plus

Tracts, commercial, industrial	—	%	—	—	2.0
Apartments	—	%	—	—	1.5

Fund control fees (costs per \$1,000 disbursed)

To \$100,000	—	LS	—	—	800.00
Over \$100,000 to \$300,000, \$800 plus	—	M\$	—	—	3.00
Over \$300,000 to \$500,000, \$1,340 plus	—	M\$	—	—	2.25
Over \$500,000 to \$1,000,000, \$1,790 plus	—	M\$	—	—	2.00
Over \$1,000,000 to \$7,000,000, \$2,795 plus	—	M\$	—	—	.90
Over \$7,000,000, \$8,195 plus	—	M\$	—	—	.75

Project Scheduling by CPM (Critical Path Method). Includes consultation, review of construction documents, development of construction logic, and graphic schedule. Project scheduling software can be purchased for home use. Costs typically will be between \$1,000.00 and \$2,500.00

Wood frame buildings, one or two stories

Simple schedule	—	LS	—	—	915.00
Complex schedule	—	LS	—	—	2,190.00

Tilt-up concrete buildings, 10,000 to 50,000 SF

Simple schedule	—	LS	—	—	1,250.00
Complex schedule	—	LS	—	—	1,860.00

Two to five story buildings (mid rise)

Simple schedule	—	LS	—	—	2,250.00
Complex schedule	—	LS	—	—	3,190.00

Five to ten story buildings (high rise)

Simple schedule	—	LS	—	—	3,650.00
Complex schedule	—	LS	—	—	9,150.00

Manufacturing plants and specialized use low rise buildings

Simple schedule	—	LS	—	—	1,630.00
Complex schedule	—	LS	—	—	2,240.00

Comprehensive schedules to meet government or owner specifications may cost 20% to 40% more. Daily schedule updates can increase costs by 40% to 50%.

Sewer Connection Fees Check with the local sanitation district for actual charges. These costs are typical for work done by city or county crews and include excavation, re-compaction and repairs to the street. Note that these costs are set by local government and will vary widely. These costs do not include capacity fees or other charges which are often levied on connection to new construction. The capacity fee per living unit may be \$3,000 or more. For commercial buildings, figure 20 fixture units equal one living unit. A 6" sewer connection will be required for buildings that include more than 216 fixture units. (Bathtubs, showers and sinks are 2 fixture units, water closets are 4, clothes washers are 3 and lavatories are 1.) The costs shown assume that work will be done by sanitation district crews. Similar work done by a private contractor under a public improvement permit may cost 50% less.

01 General Requirements

	Craft@Hrs	Unit	Material	Labor	Total
Typical charges based on main up to 11' deep and lateral up to 5' deep.					
4" connection and 40' run to main in street	—	LS	—	—	1,830.00
4" pipe runs over 40' to street	—	LF	—	—	41.30
6" connection and 40' run to main in street	—	LS	—	—	2,980.00
6" pipe runs over 40' to street	—	LF	—	—	70.50
4" connection and 15' run to main in alley	—	LS	—	—	1,330.00
6" connection and 15' run to main in alley	—	LS	—	—	2,140.00
Manhole cut-in	—	Ea	—	—	362.00
Add for main depths over 5'					
Over 5' to 8'	—	%	—	—	30.0
Over 8' to 11'	—	%	—	—	60.0
Over 11'	—	%	—	—	100.0
Water Meters Check with the local water district for actual charges. These costs are typical for work done by city or county crews and include excavation and pipe to 40' from the main, meter, vault, re-compaction and repairs to the street. These costs do not include capacity fees or other charges which are often levied on connection to new construction. The capacity fee per living unit is typically \$5,000. For commercial buildings, figure 20 fixture units equal one living unit. (Bathtubs, showers and sinks are 2 fixture units, water closets are 4, clothes washers are 3 and lavatories are 1.) The cost for discontinuing service will usually be about the same as the cost for starting new service, but no capacity fee will be charged. Add the backflow device and capacity fee, if required.					
1" service, 3/4" meter	—	LS	—	—	3,160.00
1" service, 1" meter	—	LS	—	—	3,260.00
Add for 1" service per LF over 40'	—	LF	—	—	75.40
2" service, 1-1/2" meter	—	LS	—	—	3,650.00
2" service, 2" meter	—	LS	—	—	3,800.00
Add for 2" service per LF over 40'	—	LF	—	—	81.10
Two 2" service lines and meter manifold	—	LS	—	—	6,000.00
Add for two 2" lines per LF over 40'	—	LF	—	—	110.00
Hydrant meter, typical deposit is \$1,000 to \$2,000, typical water cost is \$5 per 1,000 gallons					
Rental per day	—	Day	—	—	13.30
Installation of meter only. Connected to existing water service if correct size line exists from the water main to the meter box location					
3/4" meter	—	LS	—	—	139.00
1" x 3/4" meter	—	LS	—	—	132.00
1" meter	—	LS	—	—	158.00
1-1/2" meter	—	LS	—	—	511.00
2" meter	—	LS	—	—	743.00
2" meter (double line)	—	LS	—	—	1,310.00
Backflow preventer with single check valve. Includes pressure vacuum breaker (PVB), two ball valves, one air inlet and one check valve					
1" pipe	—	LS	—	—	335.00
2" pipe	—	LS	—	—	659.00
Backflow preventer with double check valves. Includes pressure vacuum breaker (PVB), two ball or gate valves, one air inlet and two check valves					
3/4" pipe	—	LS	—	—	438.00
1" pipe	—	LS	—	—	460.00
1-1/2" pipe	—	LS	—	—	537.00
2" pipe	—	LS	—	—	719.00
Reduced pressure backflow preventer. Includes pressure reducing vacuum breaker (PRVB), two ball or gate valves, one air inlet and two check valves and a relief valve					
1" pipe	—	LS	—	—	1,160.00
2" pipe	—	LS	—	—	1,410.00
Two 2" pipes (double installation)	—	LS	—	—	2,790.00

01 General Requirements

	Craft@Hrs	Unit	Material	Labor	Total
Surveying					
Surveying party, 2 or 3 technicians					
Typical cost	—	Day	—	—	1,350.00
Higher cost	—	Day	—	—	1,730.00
Data reduction and drafting	—	Hr	—	—	81.60
Surveys Including wood hubs or pipe markers as needed. These figures assume that recorded monuments are available adjacent to the site. See also Building Layout in the Earthwork section.					
Residential lot, tract work, 4 corners	—	LS	—	—	812.00
Residential lot, individual, 4 corners	—	LS	—	—	1,390.00
Commercial lot, based on 30,000 SF lot	—	LS	—	—	1,490.00
Over 30,000 SF, add per acre	—	Acre	—	—	236.00
Lots without recorded markers cost more, depending on distance to the nearest recorded monument.					
Add up to	—	%	—	—	100.0
Some states require that a corner record be prepared and filed with the county surveyor's office when new monuments are set. The cost of preparing and filing a corner record will be about \$400.00.					
Aerial Mapping Typical costs based on a scale of 1" to 40'.					
Back up ground survey including flagging model	—	Ea	—	—	3,900.00
(Typical "model" is approximately 750' by 1,260' or 25 acres)					
Aerial photo flight, plane and crew, per local flight. One flight can cover several adjacent models					
Per local flight	—	Ea	—	—	478.00
Vertical photos (2 required per model)	—	Ea	—	—	52.00
Data reduction and drafting, per hour	—	Hr	—	—	72.70
Complete survey with finished drawing, per model, including both field work and flying					
Typical cost per model	—	Ea	—	—	4,000.00
Deduct if ground control is marked on the ground by others					
Per model	—	LS	—	—	-1,040.00
Typical mapping cost per acre including aerial control, flight and compilation					
Based on 25 acre coverage	—	Acre	—	—	187.00
Aerial photos, oblique (minimum 4 per job), one 8" x 10" print					
Black and white	—	Ea	—	—	52.00
Color	—	Ea	—	—	104.00
Quantitative studies for earthmoving operations to evaluate soil quantities moved					
Ground control and one flight	—	Ea	—	—	3,280.00
Each additional flight	—	Ea	—	—	2,230.00
Engineering Fees Typical billing rates.					
Registered engineers (calculations, design and drafting)					
Assistant engineer	—	Hr	—	—	101.00
Senior engineer	—	Hr	—	—	172.00
Principal engineers (cost control, project management, client contact)					
Assistant principal engineer	—	Hr	—	—	182.00
Senior principal engineer	—	Hr	—	—	243.00
Job site engineer (specification compliance)	—	Hr	—	—	101.00
Estimating Cost Compiling detailed labor and material cost estimate for commercial and industrial construction, in percent of job cost. Actual fees are based on time spent plus cost of support services.					
Most types of buildings, typical fees					
Under \$100,000 (range of .75 to 1.5%)	—	%	—	—	1.1
Over \$100,000 to \$500,000 (range of .5 to 1.25%)	—	%	—	—	0.9
Over \$500,000 to \$1,000,000 (range of .5 to 1.0%)	—	%	—	—	0.8
Over \$1,000,000 (range of .25 to .75%)	—	%	—	—	0.5

01 General Requirements

	Craft@Hrs	Unit	Material	Labor	Total
Complex, high-tech, research or manufacturing facilities or other buildings with many unique design features, typical fees					
Under \$100,000 (range of 2.3 to 3%)	—	%	—	—	2.7
Over \$100,000 to \$500,000 (range of 1.5 to 2.5%)	—	%	—	—	2.0
Over \$500,000 to \$1,000,000 (range of 1.0 to 2.0%)	—	%	—	—	1.5
Over \$1,000,000 (range of .5 to 1.0%)	—	%	—	—	0.8
Typical estimator's fee per hour	—	Hr	—	—	51.60

Specifications Fee Preparing detailed construction specifications to meet design requirements for commercial and industrial buildings, in percent of job cost. Actual fees are based on time spent plus cost of support services, if any.

Typical fees for most jobs	—	%	—	—	0.5
Small or complex jobs					
Typical cost	—	%	—	—	1.0
High cost	—	%	—	—	1.5
Large jobs or repetitive work					
Typical cost	—	%	—	—	0.2
High cost	—	%	—	—	0.5

Job Layout Setting layout stakes for the foundation from monuments identified on the plans and existing on site.

Per square foot of building first floor area. Typical costs. Actual costs will be based on the time required.

Smaller or more complex jobs	—	SF	—	—	.95
Large job, easy work	—	SF	—	—	.60

General Non-Distributable Supervision and Expense

Project manager, typical	—	Mo	—	—	7,120.00
Job superintendent	—	Mo	—	—	5,520.00
Factory representative	—	Day	—	—	850.00
Timekeeper	—	Mo	—	—	2,280.00
Job site engineer for layout	—	Mo	—	—	4,250.00
Office manager	—	Mo	—	—	2,560.00
Office clerk	—	Mo	—	—	1,890.00

Mobilization Typical costs for mobilization and demobilization within a 50 mile radius as a percent of total contract price. Includes cost of moving general contractor-owned equipment and job office to the site, setting up a fenced material yard, and removing equipment, office and fencing at job completion.

Allow, as a percentage of total contract price	—	%	—	—	0.5
--	---	---	---	---	-----

Aggregate Testing

Add for sample prep	—	Hr	—	—	53.20
Abrasion, L.A. Rattler, 100/500 cycles, ASTM C 131	—	Ea	—	—	131.00
Absorption, ASTM C 127, 128	—	Ea	—	—	64.50
Acid solubility	—	Ea	—	—	37.80
Aggregate test for mix design, including sieve analysis, specific gravity, number 200 wash,					
organic impurities	—	Ea	—	—	53.20
Clay lumps and friable particles, ASTM C 142	—	Ea	—	—	71.00
Coal and lignite, ASTM C 123	—	Ea	—	—	114.00
Material finer than #200 sieve, ASTM C 117	—	Ea	—	—	43.90
Organic impurities, ASTM C 40	—	Ea	—	—	55.90
Percent crushed particles, CAL 205	—	Ea	—	—	74.00
Percent flat or elongated particles, CRD C 119	—	Ea	—	—	119.00
Potential reactivity, chemical method, 3 determinations per series,					
ASTM C 289	—	Ea	—	—	374.00
Potential reactivity, mortar bar method, ASTM C 227	—	Ea	—	—	354.00

01 General Requirements

	Craft@Hrs	Unit	Material	Labor	Total
Sieve analysis, pit run aggregate	—	Ea	—	—	74.00
Lightweight aggregate ASTM C 123	—	Ea	—	—	82.80
Sand equivalent	—	Ea	—	—	94.50
Sieve analysis, processed (each size), ASTM C 136	—	Ea	—	—	86.00
Soft particles, ASTM C 235	—	Ea	—	—	74.00
Soundness, sodium or magnesium, 5 cycle, per series, ASTM C 88	—	Ea	—	—	161.00
Specific gravity, coarse, ASTM C 127	—	Ea	—	—	64.50
Specific gravity, fine, ASTM C 127	—	Ea	—	—	89.10
Unit weight per cubic foot, ASTM C 29	—	Ea	—	—	37.80
Asphaltic Concrete Testing Minimum fee is usually \$40.00.					
Asphaltic concrete core drilling, field or laboratory					
Per linear inch	—	Ea	—	—	5.69
Add for equipment and technician for core drilling	—	Hr	—	—	75.10
Asphaltic core density	—	Ea	—	—	26.80
Extraction, percent asphalt (Method B), excluding ash correction, ASTM D 2172	—	Ea	—	—	64.40
Gradation on extracted sample (including wash), ASTM C 136	—	Ea	—	—	80.70
Maximum density, lab mixed, Marshall, 1559	—	Ea	—	—	188.00
Maximum density, premixed, Marshall, 1559	—	Ea	—	—	135.00
Maximum theoretical unit weight (Rice Gravity), ASTM 2041	—	Ea	—	—	80.70
Penetration, ASTM D 5	—	Ea	—	—	64.50
Stability, lab mixed, Marshall, ASTM D 1559	—	Ea	—	—	268.00
Stability, premixed, Marshall, ASTM D 1559	—	Ea	—	—	163.00
Concrete Testing Minimum fee is usually \$40.00.					
Aggregate tests for concrete mix designs only, including sieve analysis, specific gravity, number 200 wash, organic impurities, weight per cubic foot					
Per aggregate size	—	Ea	—	—	77.30
Amend or re-type existing mix designs					
Not involving calculations	—	Ea	—	—	45.10
Compression test, 2", 4", or 6" cores (excludes sample preparation) ASTM C 42	—	Ea	—	—	39.70
Compression test, 6" x 12" cylinders, including mold ASTM C 39	—	Ea	—	—	14.00
Core cutting in laboratory	—	Ea	—	—	45.10
Cylinder pickup within 40 miles of laboratory					
Cost per cylinder (minimum of 3)	—	Ea	—	—	9.66
Flexure test, 6" x 6" beams, ASTM C 78	—	Ea	—	—	56.90
Laboratory trial, concrete batch, ASTM C 192	—	Ea	—	—	372.00
Length change (3 bars, 4 readings, up to 90 days)					
ASTM C 157 modified	—	LS	—	—	256.00
Additional readings, per set of 3 bars	—	LS	—	—	39.70
Storage over 90 days, per set of 3 bars, per month	—	Mo	—	—	39.80
Modulus of elasticity test, static, ASTM C 469	—	Ea	—	—	78.30
Mix design, determination of proportions	—	Ea	—	—	84.90
Pick up aggregate sample					
Within 40 mile radius of laboratory, per trip	—	Ea	—	—	50.50
Pickup or delivery of shrinkage molds, per trip	—	Ea	—	—	34.40
Prepare special strength documentation for mix design	—	Ea	—	—	95.50

01 General Requirements

	Craft@Hrs	Unit	Material	Labor	Total
Proportional analysis, cement factor and percent of aggregate					
Per analysis	—	Ea	—	—	246.00
Review mix design prepared by others	—	Ea	—	—	73.00
Splitting tensile, 6" x 12" cylinder, ASTM C 496	—	Ea	—	—	34.40
Weight per cubic foot determination of lightweight concrete cylinders	—	Ea	—	—	6.45
Masonry and Tile Testing					
Brick, ASTM C 67					
Modulus of rupture (flexure) or compressive strength	—	Ea	—	—	29.10
Absorption initial rate, 5 hour or 24 hour	—	Ea	—	—	23.60
Boil, 1, 2, or 5 hours	—	Ea	—	—	23.40
Efflorescence	—	Ea	—	—	29.00
Dimensions, overall, coring, shell and web	—	Ea	—	—	23.60
Compression of core	—	Ea	—	—	39.70
Cores, shear, 6" and 8" diameter, 2 faces, per core	—	Ea	—	—	50.50
Coefficient of friction (slip test)	—	Ea	—	—	90.20
Concrete block, ASTM C 140					
Moisture content as received	—	Ea	—	—	23.60
Absorption	—	Ea	—	—	29.00
Compression	—	Ea	—	—	34.40
Shrinkage, modified British, ASTM C 426	—	Ea	—	—	73.00
Compression, 4", 6", 8" cores	—	Ea	—	—	39.70
Fireproofing, oven dry density	—	Ea	—	—	34.40
Guniting					
Compression, 2", 4", 6" cores, ASTM C 42	—	Ea	—	—	39.80
Pickup guniting field sample (40 mile trip maximum)	—	Ea	—	—	56.90
Building stone					
Compression	—	Ea	—	—	34.40
Flex strength	—	Ea	—	—	34.40
Modules/rupture	—	Ea	—	—	34.40
Specific gravity	—	Ea	—	—	34.40
Water absorption	—	Ea	—	—	34.40
Masonry prisms, ASTM E 447					
Compression test, grouted prisms	—	Ea	—	—	146.00
Pickup prisms, within 40 miles of lab	—	Ea	—	—	39.70
Mortar and grout, UBC Standard 24-22 & 24-28					
Compression test, 2" x 4" mortar cylinder	—	Ea	—	—	19.40
Compression test, 3" x 6" grout prisms	—	Ea	—	—	25.60
Compression test, 2" cubes, ASTM C 109	—	Ea	—	—	50.50
Roof fill, lightweight ASTM C 495					
Compression test	—	Ea	—	—	23.60
Density	—	Ea	—	—	17.30
Roofing tile					
Roofing tile breaking strength, UBC	—	Ea	—	—	23.40
Roofing tile absorption	—	Ea	—	—	23.40
Reinforcement Testing					
Sampling at fabricator's plant (within 40 miles of lab), \$50.00 minimum					
During normal business hours, per sample	—	Ea	—	—	19.40
Other than normal business hours, per sample	—	Ea	—	—	29.10
Tensile test, mechanically spliced bar	—	Ea	—	—	108.00
Tensile test, number 11 bar or smaller, ASTM 615	—	Ea	—	—	28.00

01 General Requirements

	Craft@Hrs	Unit	Material	Labor	Total
Tensile test, number 14 bar or smaller, ASTM 615	—	Ea	—	—	62.20
Tensile test, number 18 bar, ASTM 615	—	Ea	—	—	73.00
Tensile test, welded number 11 bar or smaller	—	Ea	—	—	39.80
Tensile test, welded number 14 bar	—	Ea	—	—	72.90
Tensile test, welded number 18 bar	—	Ea	—	—	90.20
Tensile and elongation test for pre-stress strands					
24" test, ASTM A 416	—	Ea	—	—	90.10
10" test, ASTM A 421	—	Ea	—	—	50.50
Soils and Aggregate Base Testing Minimum fee is usually \$400.					
Bearing ratio (excluding moisture-density curve)	—	Ea	—	—	119.00
Consolidation test (single point)	—	Ea	—	—	80.60
Consolidation test (without rate data)	—	Ea	—	—	102.00
Direct shear test					
Unconsolidated, undrained	—	Ea	—	—	69.80
Consolidated, undrained	—	Ea	—	—	108.00
Consolidated, drained	—	Ea	—	—	135.00
Durability index – coarse and fine	—	Ea	—	—	150.00
Expansion index test, UBC 29-2	—	Ea	—	—	119.00
Liquid limit or plastic limit, Atterberg limits	—	Ea	—	—	108.00
Mechanical analysis – ASTM D1140 (wash 200 sieve)	—	Ea	—	—	43.90
Mechanical analysis – sand and gravel (wash sieve)	—	Ea	—	—	125.00
Moisture content	—	Ea	—	—	16.30
Moisture-density curve for compacted fill, ASTM 1557					
4-inch mold	—	Ea	—	—	140.00
6-inch mold	—	Ea	—	—	150.00
Permeability (falling head)	—	Ea	—	—	240.00
Permeability (constant head)	—	Ea	—	—	188.00
Resistance value	—	Ea	—	—	234.00
Sand equivalent	—	Ea	—	—	69.90
Specific gravity – fine-grained soils	—	Ea	—	—	64.50
Unconfined compression test (undisturbed sample)	—	Ea	—	—	75.10
Unit dry weight and moisture content (undisturbed sample)	—	Ea	—	—	22.50
Steel Testing \$100.00 minimum for machine time.					
Charpy impact test, reduced temperature	—	Ea	—	—	28.00
Charpy impact test, room temperature	—	Ea	—	—	14.00
Electric extensometer	—	Ea	—	—	67.60
Hardness tests, Brinell or Rockwell	—	Ea	—	—	23.60
Photo micrographs					
20× to 2,000×	—	Ea	—	—	23.60
With negative	—	Ea	—	—	28.00
Tensile test, under 100,000 lbs	—	Ea	—	—	39.70
Welder Qualification Testing. Add \$36 minimum per report					
Tensile test	—	Ea	—	—	39.70
Bend test	—	Ea	—	—	28.00
Macro etch	—	Ea	—	—	56.90
Fracture test	—	Ea	—	—	34.40
Machining for weld tests, 1/2" and less	—	Ea	—	—	39.80
Machining for weld tests, over 1/2"	—	Ea	—	—	56.90

01 General Requirements

	Craft@Hrs	Unit	Material	Labor	Total
Construction Photography Digital, professional quality work, hand printed, labeled, numbered and dated. High resolution photographs on a memory card or lower resolution delivered as an email attachment.					
Job progress photos, includes shots of all building corners, two 8" x 10" color prints of each shot, per visit					
Typical cost	—	LS	—	—	592.00
High cost	—	LS	—	—	675.00
Periodic survey visits to job site to figure angles (for shots of all building corners)					
Minimum two photos, per visit	—	Ea	—	—	384.00
Exterior completion photographs, two 8" x 10" prints (two angles)					
Black and white	—	Ea	—	—	586.00
Color	—	Ea	—	—	588.00
Interior completion photographs, with lighting setup, two 8" x 10" prints of each shot (minimum three shots)					
Black and white	—	Ea	—	—	670.00
Color	—	Ea	—	—	688.00
Reprints or enlargements from existing digital file. Hand (custom) prints					
8" x 10", black and white	—	Ea	—	—	26.40
11" x 14", black and white	—	Ea	—	—	37.20
8" x 10", color	—	Ea	—	—	29.20
11" x 14", color	—	Ea	—	—	40.00
Retouching services (taking out phone lines, power poles, autos, signs, etc.) will run about \$100.00 per hour of computer time.					
Signs and Markers Pipe markers, self-stick vinyl, by overall outside diameter of pipe or covering, meets OSHA and ANSI requirements. Costs are based on standard wording and colors.					
3/4" to 1-3/8" diameter, 1/2" letters, 8" long	PA@.077	Ea	3.35	4.14	7.49
1-1/2" to 2 3/8" diameter, 3/4" letters, 8" long	PA@.077	Ea	3.35	4.14	7.49
2 1/2" to 7 7/8" diameter, 1-1/4" letters, 12" long	PA@.077	Ea	5.10	4.14	9.24
8" to 10" diameter, 2-1/2" letters, 24" long	PA@.095	Ea	7.30	5.11	12.41
Flow arrows, 2" wide tape x 108' roll, perforated every 8" (use \$50.00 as minimum material cost)	PA@.095	Ea	71.90	5.11	77.01
Barrier tapes, 3" wide x 1,000' long. "Caution", "Danger", "Open Trench", and other stock wording (Use \$35.00 as minimum material cost.) Labor shown is based on one man installing 500 LF in 1 hour.					
3 mil thick, short-term or indoor use	PA@.002	LF	.02	.11	.13
4 mil thick, long-term or outdoor use	PA@.002	LF	.06	.11	.17
Traffic control signage, "No Parking Between Signs", "Customer Parking", and other stock traffic control signs and graphics, reflective aluminum signs except as noted.					
12" x 18"	PA@.455	Ea	51.40	24.50	75.90
18" x 24"	PA@.455	Ea	89.70	24.50	114.20
24" x 8", Diamond grade (highly reflective)	PA@.455	Ea	95.30	24.50	119.80
24" x 12", Diamond grade (highly reflective)	PA@.455	Ea	108.00	24.50	132.50
24" x 18"	PA@.455	Ea	89.70	24.50	114.20
24" x 24"	PA@.455	Ea	100.00	24.50	124.50
30" x 30"	PA@.455	Ea	159.00	24.50	183.50
Add for 8' breakaway pole and mounting	CL@1.00	Ea	32.00	41.70	73.70
Add for aluminum signs	—	Ea	9.74	—	9.74
Temporary Utilities No permit fees included.					
Drop pole for electric service					
Power pole installation, wiring, 6 months rent and pickup					
100 amp meter pole	—	Ea	—	—	510.00
200 amp meter pole	—	Ea	—	—	671.00

01 General Requirements

	Craft@Hrs	Unit	Material	Labor	Total
Electric drop line and run to contractor's panel (assuming proper phase, voltage and service are available within 100' of site)					
Overhead run to contractor's "T" pole (including removal)					
Single phase, 100 amps	—	LS	—	—	409.00
Single phase, over 100 to 200 amps	—	LS	—	—	554.00
Three phase, to 200 amps	—	LS	—	—	637.00
Underground run in contractor's trench and conduit (including removal)					
Single phase, 100 amps, "USA" wire	—	LS	—	—	590.00
Single phase, 101-200 amps, "USA" wire	—	LS	—	—	763.00
Three phase, to 200 amps, "USA" wire	—	LS	—	—	846.00
Typical power cost					
Per kilowatt hour (\$5.00 minimum)	—	Ea	—	—	.15
Per 1,000 SF of building per month of construction	—	MSF	—	—	2.41
Temporary water service, meter installed on fire hydrant. Add the cost of distribution hose or piping.					
Meter fee, 2" meter (excluding \$400 deposit)	—	LS	—	—	84.30
Water cost, per 1,000 gallons	—	M	—	—	2.06
Job phone, typical costs including message unit charges					
Cellular phone and one year service	—	LS	—	—	606.00
Portable job site toilets, including delivery, weekly service, and pickup, per 28 day month, six month contract					
Good quality (polyethylene)					
Deluxe quality, with sink, soap dispenser, towel dispenser, mirror	—	Mo	—	—	75.60
Deluxe quality, with sink, soap dispenser, towel dispenser, mirror	—	Mo	—	—	121.00
Trailer-mounted male and female compartment double, 2 stalls in each, sink, soap dispenser, mirror and towel dispenser in each compartment					
Rental per week	—	Wk	—	—	338.00
Construction Elevators and Hoists					
Hoisting towers to 200', monthly rent					
Material hoist	C0@176.	Mo	5,790.00	10,200.00	15,990.00
Personnel hoist	C0@176.	Mo	12,700.00	10,200.00	22,900.00
Tower cranes, self-climbing (electric), monthly rent					
5 ton lift at 180' radius, one operator	C0@176.	Mo	32,600.00	10,200.00	42,800.00
With two operators	C0@352.	Mo	33,300.00	20,400.00	53,700.00
7 ton lift at 170' radius, one operator	C0@176.	Mo	43,100.00	10,200.00	53,300.00
With two operators	C0@352.	Mo	46,900.00	20,400.00	67,300.00
Mobilize, erect and dismantle self-climbing tower cranes					
Good access	—	LS	—	—	77,600.00
Average access	—	LS	—	—	94,300.00
Poor access	—	LS	—	—	154,000.00
Hydraulic Truck Cranes Includes equipment rental and operator. Four hour minimum. Time charge begins at the rental yard. By rated crane capacity.					
12-1/2 ton	—	Hr	—	—	303.00
15 ton	—	Hr	—	—	318.00
25 ton	—	Hr	—	—	296.00
50 ton	—	Hr	—	—	392.00
70 ton	—	Hr	—	—	484.00
80 ton	—	Hr	—	—	482.00
100 ton	—	Hr	—	—	500.00

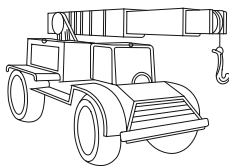

01 General Requirements

	Craft@Hrs	Unit	Material	Labor	Total
125 ton	—	Hr	—	—	559.00
150 ton	—	Hr	—	—	589.00
Add for clamshell or breaker ball work	—	Hr	—	—	61.00

Conventional Cable Cranes Including equipment rental and operator. Four hour minimum. Time charge begins at the rental yard. By rated crane capacity with 80' boom.

50 tons	—	Hr	—	—	445.00
70 tons	—	Hr	—	—	502.00
90 tons	—	Hr	—	—	564.00
125 tons	—	Hr	—	—	781.00
140 tons	—	Hr	—	—	606.00

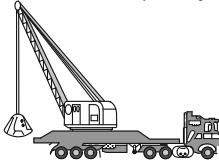

Equipment Rental Rates Costs are for equipment in good condition but exclude accessories. Includes the costs of damage waiver (about 10% of the rental cost), insurance, fuel, and oil. Add the cost of an equipment operator, pickup, return to yard and repairs, if necessary. Delivery and pickup within 30 miles of the rental yard are usually offered at an additional cost of one day's rent. A rental "day" is assumed to be one 8-hour shift and begins when the equipment leaves the rental yard. A "week" is 40 hours in five consecutive days. A "month" is 176 hours in 30 consecutive days.

	Day	Week	Month
Air equipment rental			
Air compressors, wheel-mounted			
16 CFM, shop type, electric	79.00	184.00	549.00
30 CFM, shop type, electric	84.00	252.00	756.00
80 CFM, shop type, electric	98.00	299.00	893.00
100 CFM, gasoline unit	134.00	399.00	1,120.00
125 CFM, gasoline unit	165.00	498.00	1,490.00
Air compressors wheel-mounted diesel units			
to 159 CFM	124.00	372.00	1,120.00
160 - 249 CFM	165.00	498.00	1,490.00
250 - 449 CFM	250.00	747.00	2,230.00
450 - 749 CFM	332.00	994.00	2,980.00
750 - 1,200 CFM	662.00	1,990.00	5,970.00
1,400 CFM and over	828.00	2,490.00	8,450.00
Paving breakers (no bits included) hand-held, pneumatic			
to 40 lb	52.00	166.00	366.00
41 - 55 lb	83.00	297.00	624.00
56 - 70 lb	69.00	239.00	472.00
71 - 90 lb	119.00	282.00	605.00
Paving breakers jackhammer bits			
Moil points, 15" to 18"	11.00	23.00	42.00
Chisels, 3"	11.00	21.00	39.00
Clay spades, 5-1/2"	19.00	52.00	101.00
Asphalt cutters, 5"	14.00	27.00	62.00
Rock drills, jackhammers, hand-held, pneumatic			
to 29 lb	48.00	142.00	352.00
30 - 39 lb	75.00	309.00	625.00
40 - 49 lb	110.00	589.00	642.00
50 lb and over	64.00	221.00	758.00
Rock drill bits, hexagonal			
7/8", 2' long	15.00	34.00	63.00
1", 6' long	13.00	34.00	68.00

01 General Requirements

	Day	Week	Month
Pneumatic chippers, medium weight, 10 lb	107.00	244.00	454.00
Pneumatic tampers, medium weight, 30 lb	38.00	126.00	445.00
Pneumatic grinders, hand-held, 7 lb (no stone)	31.00	75.00	197.00
Air hose, 50 LF section			
5/8" air hose	10.00	19.00	46.00
3/4" air hose	12.00	25.00	58.00
1" air hose	15.00	34.00	70.00
1-1/2" air hose	23.00	67.00	172.00
Compaction equipment rental			
Vibro plate, 300 lb, 24" plate width, gas	164.00	524.00	1,110.00
Vibro plate, 600 lb, 32" plate width, gas	333.00	878.00	1,930.00
Rammer, 60 CPM, 200 lb, gas powered	115.00	351.00	745.00
Rollers, two axle steel drum, road type			
1 ton, gasoline	387.00	1,160.00	2,940.00
6 - 8 ton, gasoline	500.00	1,520.00	3,750.00
8 - 10 ton	616.00	1,960.00	5,010.00
Rollers, rubber tired, self propelled			
12 ton, 9 wheel, diesel	513.00	1,530.00	4,490.00
15 ton, 9 wheel, diesel	696.00	3,030.00	6,430.00
30 ton, 11 wheel, diesel	717.00	2,450.00	5,390.00
Rollers, towed, sheepsfoot type			
40" diameter, double drum, 28" wide	192.00	724.00	1,740.00
60" diameter, double drum, 54" wide	336.00	978.00	3,000.00
Rollers, self-propelled vibratory dual sheepsfoot drum, gas			
25 HP, 26" wide roll	565.00	1,910.00	5,750.00
100 HP, 36" wide roll	1,170.00	4,640.00	13,700.00
Rollers, vibrating steel drum, gas powered, walk behind			
7 HP, 1,000 lb, one drum, 2' wide	200.00	696.00	1,550.00
10 HP, 2,000 lb, two drum, 2'-6" wide	151.00	575.00	1,610.00
Rollers, self-propelled riding type, vibrating steel drum			
9,000 lb, gasoline, two drum	305.00	948.00	2,500.00
15,000 lb, diesel, two drum	523.00	2,300.00	5,600.00
25,000 lb, diesel, two drum	734.00	2,090.00	6,060.00
			
Concrete equipment rental			
Buggies, push type, 7 CF	91.00	638.00	940.00
Buggies, walking type, 12 CF	133.00	288.00	835.00
Buggies, riding type, 14 CF	181.00	508.00	834.00
Buggies, riding type, 18 CF	125.00	396.00	818.00
Vibrator, electric, 3 HP, flexible shaft	71.00	223.00	525.00
Vibrator, gasoline, 6 HP, flexible shaft	98.00	288.00	860.00
Troweling machine, 36", 4 paddle	75.00	243.00	672.00
Cement mixer, 6 CF	135.00	402.00	839.00
Towable mixer (10+ CF)	126.00	422.00	685.00
Power trowel 36", gas, with standard handle	75.00	243.00	672.00
Bull float	16.00	48.00	113.00
Concrete saws, gas powered, excluding blade cost			
10 HP, push type	145.00	357.00	789.00
20 HP, self propelled	199.00	578.00	1,170.00
37 HP, self propelled	289.00	869.00	1,950.00

01 General Requirements

	Day	Week	Month
Concrete bucket, bottom dump 1 CY	100.00	295.00	631.00
Plaster mixer, gas, portable, 5 CF	105.00	215.00	649.00
Concrete conveyor, belt type, portable, gas powered			
All sizes	154.00	559.00	1,620.00
Vibrating screed, 16', single beam	94.00	302.00	651.00
Column clamps, to 48", per set	—	—	11.00
Crane rental Add for clamshell, dragline, or pile driver attachments from below.			
Cable controlled crawler-mounted lifting cranes, diesel			
45 ton	—	3,660	10,400.00
60 ton	—	5,450.00	12,200.00
100 ton (125 ton)	2,060.00	6,230.00	20,000.00
150 ton	3,030.00	8,970.00	27,300.00
Cable controlled, truck-mounted lifting cranes, diesel			
50 ton	723.00	2,130.00	6,930.00
75 ton	920.00	2,740.00	8,310.00
100 ton	1,330.00	4,000.00	10,400.00
Hydraulic – rough terrain			
10 ton, gasoline	455.00	1,320.00	3,820.00
17 ton, diesel	568.00	1,610.00	4,500.00
35 ton, diesel	669.00	2,370.00	7,000.00
50 ton, diesel	1,550.00	4,700.00	13,200.00
Clamshell, dragline, and pile driver attachments Add to crane rental costs shown above.			
Clamshell buckets			
Rehandling type, 1 CY	—	362.00	1,070.00
General purpose, 2 CY	91.00	583.00	1,530.00
Dragline buckets			
1 CY bucket	50.00	124.00	347.00
2 CY bucket	96.00	347.00	722.00
Pile drivers, hammers			
25,000 - 49,999 ft-lb	585.00	2,610.00	4,690.00
75 - 99 tons vibratory	1,410.00	3,370.00	9,180.00
1,000 - 1,999 ft-lb extractor	—	832.00	2,210.00
Excavation equipment rental			
Backhoe/loaders, crawler mounted, diesel			
3/8 CY backhoe	344.00	1,220.00	3,340.00
3/4 CY backhoe	388.00	1,380.00	3,210.00
1-1/2 CY backhoe	423.00	1,330.00	3,970.00
2 CY backhoe	653.00	2,000.00	4,750.00
2-1/2 CY backhoe	963.00	2,980.00	8,160.00
Backhoe/loaders, wheel mounted, diesel or gasoline			
1/2 CY bucket capacity, 55 HP	259.00	796.00	1,840.00
1 CY bucket capacity, 65 HP	240.00	740.00	2,230.00
1-1/4 CY bucket capacity, 75 HP	234.00	787.00	2,180.00
1-1/2 CY bucket capacity, 100 HP	417.00	1,150.00	2,940.00
Mounted with 750-lb. breaker	546.00	1,900.00	5,680.00
Mounted with 2,000-lb. breaker	811.00	3,070.00	8,540.00

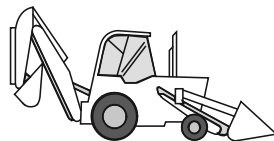

01 General Requirements

	Day	Week	Month
Crawler dozers, with angle dozer or bulldozer blade, diesel			
65 HP, D-3	477.00	1,440.00	4,030.00
90-105 HP, D-4 or D-5	668.00	1,810.00	5,010.00
140 HP, D-6	911.00	2,600.00	7,530.00
200 HP, D-7	1,340.00	3,830.00	11,100.00
335 HP, D-8	1,800.00	5,540.00	16,900.00
460 HP, D-9	3,880.00	9,120.00	27,300.00
Crawler loaders, diesel			
3/4 CY loader	380.00	1,380.00	3,210.00
1-1/2 CY loader	423.00	1,330.00	3,970.00
2 CY loader	653.00	2,000.00	4,750.00
Hydraulic excavators, crawler mounted with backhoe type arm, diesel			
.2 - .4 CY bucket	597.00	1,730.00	3,980.00
.4 - .6 CY bucket	562.00	1,680.00	3,820.00
.6 - .8 CY bucket	541.00	1,680.00	4,820.00
Gradall, truck mounted, diesel			
3/4 CY bucket	1,070.00	3,200.00	9,230.00
1 CY bucket	1,300.00	5,690.00	16,900.00
Front-end loader, diesel or gas (Skiploader)			
40-hp	169.00	574.00	1,510.00
60-hp	290.00	948.00	2,250.00
80-hp	329.00	961.00	2,300.00
Skid steer loaders			
Bobcat 643, 1,000-lb capacity	259.00	902.00	2,060.00
Bobcat 753, 1,350-lb capacity	254.00	815.00	1,800.00
Bobcat 763, 1,750-lb capacity	310.00	902.00	2,040.00
Bobcat 863, 1,900-lb capacity	301.00	910.00	2,140.00
Skid steer attachments			
Auger	151.00	480.00	871.00
Hydraulic breaker	187.00	550.00	1,610.00
Backhoe	123.00	280.00	1,130.00
Sweeper	153.00	370.00	892.00
Grapple bucket	60.00	167.00	488.00
Wheel loaders, front-end load and dump, diesel			
3/4 CY bucket, 4WD, articulated	203.00	692.00	2,090.00
1 CY bucket, 4WD, articulated	358.00	1,040.00	2,920.00
3-1/4 CY bucket, 4WD, articulated	867.00	1,470.00	6,750.00
5 CY bucket, 4WD, articulated	1,020.00	3,100.00	9,820.00
Motor scraper-hauler, 2 wheel tractor			
Under 18 CY capacity, single engine	2,160.00	5,930.00	16,500.00
18 CY and over, single engine	2,550.00	8,140.00	24,200.00
Under 18 CY capacity, Two engine	3,100.00	8,860.00	25,600.00
18 CY and over, Two engine	1,920.00	7,060.00	24,600.00
Graders, diesel, pneumatic tired, articulated			
100 HP	708.00	2,000.00	5,630.00
150 HP	958.00	2,900.00	10,000.00
200 HP	1,320.00	4,240.00	12,700.00
Trenchers, inclined chain boom type, pneumatic tired			
15 HP, 12" wide, 48" max. depth, walking	229.00	664.00	1,820.00
20 HP, 12" wide, 60" max. depth, riding	349.00	1,040.00	3,000.00
100 HP, 24" x 96" deep, crawler mount	1,780.00	5,120.00	13,700.00

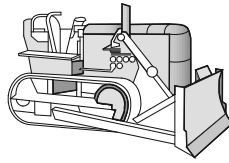

01 General Requirements

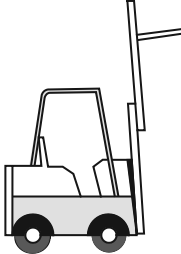
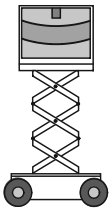
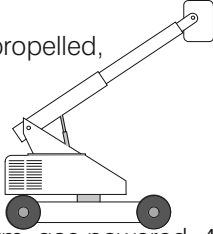
	Day	Week	Month
Trenching shields, steel, 8' high x 12' long			
Single wall	151.00	390.00	1,150.00
Hydraulic trench braces, 8' long, to 42" wide	27.00	77.00	234.00
Truck-mounted wagon drills, self propelled, crawler mounted			
4" drifter, straight boom	668.00	1,770.00	4,810.00
4-1/2" drifter, hydraulic swing boom	1,020.00	3,840.00	9,010.00
Truck rental			
1-1/2 ton truck	112.00	334.00	1,000.00
Flatbed with boom	627.00	1,930.00	5,550.00
Dump trucks, rental rate plus mileage			
3 CY	430.00	1,130.00	2,200.00
5 CY	455.00	1,200.00	3,470.00
10 CY	959.00	3,030.00	3,830.00
25 CY off highway	—	4,780.00	13,800.00
Forklift rental			
Rough terrain, towable, gas powered			
4,000 lb capacity	285.00	797.00	2,030.00
8,000 lb capacity	439.00	1,100.00	2,490.00
Extension boom, 2 wheel steering			
4,000 lb, 30' lift	541.00	1,150.00	2,460.00
6,000 lb, 35' lift	519.00	1,400.00	2,860.00
8,000 lb, 40' lift, 4 wheel steering	625.00	1,530.00	2,980.00
			
Aerial platform rental			
Rolling scissor lifts, 2' x 3' platform, 650 lb capacity, push around, electric powered			
30' high	332.00	633.00	1,080.00
40' high	388.00	978.00	1,850.00
50' high	566.00	1,430.00	2,850.00
Rolling scissor lifts, self-propelled, hydraulic, electric powered			
To 20'	162.00	333.00	647.00
21' - 30'	356.00	1,080.00	1,670.00
31' - 40'	223.00	466.00	954.00
			
Rolling scissor lifts, self-propelled, hydraulic, diesel powered			
To 20'	110.00	274.00	713.00
21' - 30'	305.00	650.00	1,320.00
31' - 40'	342.00	713.00	1,490.00
Boomlifts, telescoping and articulating booms, self-propelled, gas or diesel powered, 2-wheel drive			
21' - 30'	308.00	658.00	1,842.00
31' - 40'	418.00	1,040.00	2,050.00
41' - 50'	547.00	1,380.00	3,070.00
51' - 60'	610.00	1,490.00	3,220.00
			
Bucket truck, 38 ft insulated bucket on articulating arm, gas powered, 4-wheel drive			
Bucket truck w/ 3 story reach, articulating arm, 4x4	650.00	1,950.00	4,950.00
Pump rental Hoses not included.			
Submersible pump rental			
1-1/2" to 2", electric	72.00	218.00	505.00
3" to 4", electric	120.00	263.00	616.00
All diameters, hydraulic	246.00	729.00	2,200.00
Trash pumps, self-priming, gas			
1-1/2" connection	80.00	239.00	619.00
4" connection	68.00	236.00	691.00
6" connection	145.00	419.00	1,050.00

01 General Requirements

	Day	Week	Month
Diaphragm pumps			
2", gas, single action	102.00	321.00	1,220.00
4", gas, double action	203.00	454.00	1,230.00
Hose, coupled, 25 LF sections			
2" suction line	17.00	40.00	105.00
1-1/2" discharge line	13.00	24.00	59.00
3" discharge line	16.00	38.00	110.00
Sandblasting equipment rental			
Compressor and hopper			
To 250 PSI	75.00	254.00	703.00
Over 250 to 300 PSI	104.00	334.00	963.00
Over 600 PSI to 1,000 PSI	150.00	484.00	1,240.00
Sandblasting accessories			
Hoses, 50', coupled			
3/4" sandblast hose or air hose	16.00	47.00	119.00
1" air hose	25.00	74.00	205.00
1-1/4" air hose or sandblast hose	15.00	36.00	90.00
Nozzles, all types	34.00	99.00	297.00
Valve, remote control (deadman), all sizes	48.00	58.00	170.00
Air-fed hood	30.00	81.00	131.00
Roadway equipment rental			
Boom mounted pavement breaker, hydraulic 1,500 lb	438.00	1,280.00	3,120.00
Paving breaker, backhoe mount, pneumatic, 1,000 lb	259.00	879.00	2,240.00
Asphalt curbing machine	138.00	420.00	1,270.00
Paving machine diesel, 10' width, self propelled	—	5,320.00	15,900.00
Distribution truck for asphalt prime coat, 3,000 gallon	1,480.00	4,530.00	14,600.00
Pavement striper, 1 line, walk behind,	98.00	202.00	505.00
Water blast truck for 1,000 PSI pavement cleaning	1,840.00	5,190.00	16,800.00
Router-groover for joint or crack sealing in pavement	291.00	950.00	2,980.00
Sealant pot for joint or crack sealing	349.00	1,050.00	3,460.00
Self-propelled street sweeper, vacuum (7 CY max.)	1,260.00	3,860.00	11,600.00
Water trucks/tanks			
1,800-gallon water truck	291.00	1,000.00	2,990.00
3,500-gallon water truck	503.00	2,020.00	5,750.00
Water tower	218.00	651.00	1,950.00
Tow behind trailer, 500 gal.	108.00	280.00	847.00
Off-road water tanker, 10,000 gal.	437.00	1,500.00	4,485.00
Steel road plate, 1" thick A-36 grade steel, with lifting eyes. Add the cost of delivery and pickup.			
4' x 4'	83.00	83.00	248.00
5' x 10'	24.00	68.00	273.00
7' x 10'	57.00	136.00	433.00
8' x 8'	85.00	179.00	530.00
8' x 20'	61.00	151.00	460.00

01 General Requirements

	Day	Week	Month
Traffic control equipment rental			
Trailer-mount solar powered LED message board	234.00	600.00	1,250.00
Arrow board – 25 lights	100.00	279.00	691.00
Barricades	10.00	25.00	77.00
Barricades with flashers	11.00	29.00	88.00
Delineators	11.00	17.00	26.00
Drill rental			
1/2" cordless drill, 18 volt	23.00	88.00	221.00
3/8" or 1/2", electric drill	34.00	113.00	175.00
3/4" electric drill	38.00	136.00	363.00
1/2" right angle electric drill	35.00	113.00	352.00
1/2" electric hammer drill	40.00	160.00	424.00
Electric generator rental			
2.5 kw, gasoline	69.00	277.00	724.00
5 kw, gasoline	93.00	374.00	1,350.00
15 kw, diesel	122.00	464.00	1,150.00
60 kw, diesel	444.00	1,210.00	3,200.00
Floor equipment rental			
Carpet blower	25.00	100.00	270.00
Carpet cleaner	33.00	132.00	376.00
Carpet kicker	18.00	72.00	200.00
Carpet power stretcher	35.00	140.00	382.00
Carpet stapler, electric	23.00	83.00	247.00
Carpet seamer, electric	19.00	76.00	200.00
Floor edger, 7", electric	47.00	188.00	473.00
Floor maintainer	63.00	252.00	717.00
Grinder 9"	36.00	146.00	381.00
Mini grinder, 4-1/2"	20.00	80.00	209.00
Pergo installation kit	43.00	130.00	351.00
Tile roller	23.00	92.00	242.00
Tile stripper, electric	61.00	244.00	650.00
Tile stripper, manual	13.00	40.00	118.00
Vacuum, 10 gallons, wet/dry	50.00	199.00	607.00
Hammer rental			
Electric brute breaker	65.00	260.00	814.00
Gas breaker	89.00	358.00	972.00
Demolition hammer, electric	58.00	323.00	650.00
Rotom hammer, 7/8", electric	65.00	260.00	704.00
Rotom hammer, 1-1/2", electric	62.00	248.00	600.00
Heater rental, fan forced			
Kerosene heater, to 200 MBtu	109.00	274.00	746.00
Kerosene heater, over 200 to 300 MBtu	69.00	248.00	637.00
Kerosene heater, over 500 to 1,000 MBtu	581.00	1,770.00	5,490.00
Salamanders, LP gas (no powered fan)	54.00	203.00	461.00
Ladder rental			
Step ladder, 6' or 8'	22.00	77.00	214.00
Step ladder, 10' or 14'	27.00	108.00	275.00
Extension ladder, 24'	35.00	140.00	400.00
Extension ladder, 28' or 32'	40.00	196.00	450.00
Extension ladder, 40'	59.00	214.00	528.00
Stairway step ladder	22.00	81.00	243.00

01 General Requirements

	Day	Week	Month
Landscape equipment rental			
Aerator, gas	91.00	364.00	1,020.00
Auger, 2 man (gas)	123.00	492.00	1,050.00
6" chipper, gas	307.00	899.00	2,240.00
Brush cutter, gas	50.00	202.00	530.00
Brush hog, 24"	69.00	272.00	800.00
Clamshovel, manual	16.00	43.00	125.00
Digging bar, 5'	16.00	50.00	149.00
Edger, lawn, gas	35.00	139.00	420.00
Fertilizer spreader	15.00	43.00	125.00
Hand auger, 6"	15.00	55.00	155.00
Hedge trimmer, 24", electric	21.00	77.00	228.00
Hedge trimmer, 30", electric	25.00	94.00	296.00
Hedge trimmer, 30", gas	41.00	164.00	485.00
Lawn roller	23.00	92.00	246.00
Leaf blower, backpack, gas	42.00	159.00	470.00
Log splitter, gas	105.00	420.00	1,300.00
Overseeder, gas	71.00	244.00	723.00
Power rake, gas	63.00	249.00	748.00
Sod cutter	104.00	416.00	1,200.00
Stump grinder, 9 HP	160.00	640.00	1,700.00
Tiller, light duty, gas	64.00	256.00	889.00
Tiller, medium duty, gas	72.00	288.00	824.00
Tiller, heavy duty, gas	98.00	392.00	1,130.00
Tree pruning shears	20.00	58.00	173.00
Weed eater, gas	44.00	176.00	468.00
Wheelbarrow	18.00	72.00	163.00
Level rental			
Laser level, small	31.00	89.00	335.00
Level kit	37.00	119.00	346.00
Transit level kit	51.00	194.00	587.00
Light tower rental			
Floodlight, 1,000 watt, on stand	41.00	112.00	271.00
To 7,000 watt trailer mounted light set, gas	150.00	358.00	827.00
Over 7,000 watt trailer mounted light set, gas	158.00	815.00	1,450.00
Extension cord, 50'	14.00	37.00	110.00
Nailer and stapler rental			
Drywall screwdriver	19.00	68.00	192.00
Finish nailer, pneumatic or cordless	39.00	156.00	383.00
Floor stapler, pneumatic	29.00	116.00	422.00
Framing nailer, cordless	29.00	116.00	422.00
Framing nailer, pneumatic, 1-1/2" to 3-1/4"	31.00	107.00	356.00
Hardwood floor nailer, 3/4"	26.00	102.00	303.00
Low velocity nail gun, single	21.00	74.00	226.00
Low velocity gun, multi	39.00	156.00	410.00
Roofing nailer, pneumatic, 1/2" to 2"	29.00	116.00	336.00
Screw gun	46.00	179.00	532.00
Underlay spot nailer	21.00	76.00	229.00

01 General Requirements

	Day	Week	Month
Painting equipment rental			
Airless paint sprayer – large	85.00	300.00	893.00
Mud mixing paddle	14.00	39.00	114.00
Pressure washer – cold, 1,500 PSI	66.00	237.00	813.00
Pressure washer – cold, 2,000 PSI	82.00	328.00	970.00
Pressure washer – cold, 3,500 PSI	100.00	400.00	1,300.00
Texture sprayer with compressor	40.00	423.00	1,220.00
Wallpaper steamer, electric	37.00	148.00	360.00
Plumbing and piping equipment rental			
Basin wrench, 3/8" to 1-1/4"	22.00	50.00	131.00
Chain wrench	19.00	48.00	130.00
Conduit & pipe cutter	25.00	67.00	191.00
Drain cleaner, corded drill, 3/8"	49.00	173.00	489.00
Laser pipe level	72.00	224.00	649.00
Pipe reamer, 1/2" to 2"	18.00	62.00	166.00
Pipe stand	22.00	66.00	188.00
Pipe wrench, 18" or 24"	24.00	67.00	187.00
Pipe wrench, 36"	24.00	67.00	187.00
Sewer snake, 100' x 5/8", electric	97.00	382.00	931.00
Sewer snake, 25' x 5/16", manual	52.00	202.00	346.00
Sewer snake, 50' x 1/2", electric	62.00	244.00	697.00
Sewer snake, 50' x 1/2", manual	41.00	151.00	449.00
Soil pipe cutter, ratchet, 6"	38.00	145.00	248.00
Toilet auger	19.00	66.00	174.00
Sanding equipment rental			
Belt sander, 3" x 21"	30.00	126.00	380.00
Belt sander, 4" x 24"	29.00	116.00	342.00
Drywall sander and vacuum	57.00	225.00	612.00
Floor sander, drum type	68.00	272.00	651.00
Floor sander, square	55.00	217.00	683.00
Orbit sander	25.00	89.00	255.00
Palm sander	15.00	60.00	163.00
Vibrator sander	24.00	83.00	249.00
Saw rental			
Band saw, electric	36.00	139.00	415.00
Bolt cutters, 24"	16.00	40.00	123.00
Bolt cutters, 36"	13.00	52.00	140.00
Chain saws, 18", gasoline	70.00	274.00	791.00
Chop saw, 14", electric	41.00	164.00	478.00
Circular saw, 8-1/4" (electric)	21.00	85.00	215.00
Compound miter saw	44.00	169.00	489.00
Jamb saw	33.00	121.00	354.00
Jig saw, electric	18.00	72.00	234.00
Masonry table saw, 2 HP	73.00	292.00	800.00
Reciprocating saw, electric	23.00	92.00	409.00
Router, 2 HP, fixed base	36.00	136.00	399.00
Sliding compound miter saw	47.00	173.00	526.00
Table saw, 10", electric	53.00	121.00	575.00
Tile cutter, manual	18.00	71.00	170.00
Tile saw and stand, wet cut	72.00	339.00	790.00

01 General Requirements

	Day	Week	Month
Scaffolding, mobile rental			
5' high, with casters	42.00	86.00	226.00
10' high, with casters	64.00	128.00	197.00
15' high, with casters	85.00	170.00	212.00
5' high, with leg jacks	41.00	82.00	190.00
10' high with leg jacks	61.00	122.00	229.00
15' high, with leg jacks	81.00	162.00	375.00
14' wide with base plates	48.00	91.00	257.00
21' wide with base plates	66.00	123.00	230.00
14' wide with leg jacks	53.00	123.00	230.00
21' wide with leg jacks	85.00	155.00	230.00
14' wide with casters	54.00	123.00	230.00
21' wide with casters	77.00	159.00	296.00
Drywall panel lift, 5 piece	40.00	161.00	259.00
Drywall scaffold	58.00	173.00	476.00
Scissor lift	401.00	685.00	1,220.00
Hook end scaffold plank, each	—	—	18.00
Plain end microlam scaffold plank 9 ft., each	—	—	4.70
Plain end microlam scaffold plank 12 ft., each	—	—	5.75

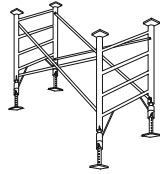

Welding equipment rental, with helmet

To 200 amp	81.00	207.00	453.00
201 to 300 amp	121.00	268.00	610.00

Miscellaneous equipment rental

Aluminum break, 10'	67.00	259.00	726.00
Appliance dolly	52.00	84.00	202.00
Chain hoist, 1 ton, 20' lift	30.00	103.00	311.00
Chain hoist, 5 ton, 20' lift	40.00	147.00	435.00
Come-a-long, 3,000 pounds	23.00	78.00	234.00
Dehumidifier, electric	72.00	288.00	442.00
Dolly, 4 wheel	15.00	47.00	140.00
Fan, low profile	80.00	171.00	436.00
Fan, 30", with pedestal	103.00	260.00	676.00
Fishtape, 200', 1/8"	19.00	57.00	172.00
Hydraulic jack, 12 ton	20.00	64.00	188.00
Loading ramps	16.00	56.00	115.00
Metal detector	22.00	74.00	225.00
Pavement line marker	22.00	75.00	225.00
Screwjack, 10 ton	17.00	52.00	151.00

Scaffolding Rental Exterior scaffolding, tubular steel, 60" wide, with 6'4" open end frames set at 7', with cross braces, base plates, mud sills, adjustable legs, post-mounted guardrail, climbing ladders and landings, brackets, clamps and building ties. Including two 2" x 10" scaffold planks on all side brackets and six 2" x 10" scaffold planks on scaffold where indicated. Add local delivery and pickup. Minimum rental is one month.

	Craft@Hrs	Unit	Material	Labor	Total
Costs are per square foot of building wall covered, per month					
With plank on scaffold only	—	SF	1.08	—	1.08
With plank on side brackets and scaffold	—	SF	1.34	—	1.34
Add for erection and dismantling, level ground, truck accessible					
With plank on scaffold only	CL@.008	SF	—	.33	.33
With planks on side brackets and scaffold	CL@.012	SF	—	.50	.50

01 General Requirements

	Craft@Hrs	Unit	Material	Labor	Total
Caster-mounted interior scaffold, purchase. Light duty					
51" high x 4' long x 22" wide	—	Ea	259.00	—	259.00
72" high x 56" long x 25" wide	—	Ea	204.00	—	204.00
Aluminum extension scaffold plank, purchase. 250-pound load capacity. 2"-deep box section extrusions. Plank length extends in 12" increments. OSHA compliant					
8' to 13' long, 14" wide	—	Ea	250.00	—	250.00
Swinging stage, 10', complete, motor operated, purchase	CL@4.00	Ea	1,570.00	167.00	1,737.00

Heavy Duty Shoring Adjustable vertical tower type shoring. Rated capacity 5.5 tons per leg. Base frames are 4' wide x 6' high or 2' wide x 5' high. Extension frames are 4' wide x 5'4" high or 2' wide x 4'4" high. Frames are erected in pairs using cross-bracing to form a tower. Combinations of base frames and extension frames are used to reach the height required. Screw jacks with base plates are installed in the bottom of each leg. Similar screw jacks with "U"-bracket heads are installed in the top of each leg. Material costs shown are rental rates based on a 1-month minimum. Add the cost of delivery and pickup. For scheduling purposes, estimate that a crew of 2 can unload, handle and erect 8 to 10 frames (including typical jacks and heads) per hour. Dismantling, handling and moving or loading will require nearly the same time.

Frames (any size), including braces and assembly hardware					
Rental per frame per month	—	Mo	13.30	—	13.30
Screw jacks (four required per frame with base plate or "U"-head)					
Rental per jack per month	—	Mo	5.49	—	5.49
Add for erecting each frame	CL@.245	Ea	—	10.20	10.20
Add for dismantling each frame	CL@.197	Ea	—	8.21	8.21

Temporary Structures Portable job site office trailers with electric air conditioners and baseboard heat, built-in desks, plan tables, insulated and paneled walls, tiled floors, locking doors and windows with screens, closet, fluorescent lights, and electrical receptacles. Add \$30 per month for units with toilet and lavatory. Monthly rental based on 6 month minimum. Dimensions are length, width and height overall and floor area (excluding hitch area).

16' x 8' x 7' high (108 SF)	—	Mo	—	—	160.00
20' x 8' x 7' high (160 SF)	—	Mo	—	—	179.00
24' x 8' x 7' high (192 SF)	—	Mo	—	—	186.00
28' x 8' x 7' high (240 SF)	—	Mo	—	—	198.00
28' x 10' x 10' high (360 SF)	—	Mo	—	—	244.00
40' x 10' x 10' high (440 SF)	—	Mo	—	—	288.00
48' x 10' x 10' high (500 SF)	—	Mo	—	—	329.00
40' x 12' x 10' high (552 SF)	—	Mo	—	—	332.00
60' x 12' x 10' high (720 SF)	—	Mo	—	—	424.00
60' x 14' x 10' high (840 SF)	—	Mo	—	—	436.00
Add for skirting, per LF of perimeter	—	LF	—	—	10.80
Deduct for unit without heating & cooling	—	Mo	—	—	-29.00
Add per set of steps	—	LS	—	—	30.10
Add for delivery, setup, blocking and dismantling of office trailers within 15 miles					
Delivery and setup	—	LS	—	—	277.00
Dismantle and pickup	—	LS	—	—	277.00
Electrical hookup	—	LS	—	—	165.00
Plumbing hookup	—	LS	—	—	224.00
Add for delivery or pickup over 15 miles, per mile					
8' wide units	—	Mile	—	—	3.79
10' wide units	—	Mile	—	—	4.09
12' wide units	—	Mile	—	—	4.41
14' wide units	—	Mile	—	—	4.92

01 General Requirements

	Craft@Hrs	Unit	Material	Labor	Total
Portable steel storage containers (lockable), suitable for job site storage of tools and materials. Rental per month, based on 6 month rental					
8' x 8' x 20'	—	Mo	—	—	79.40
8' x 8' x 24'	—	Mo	—	—	104.00
8' x 8' x 40'	—	Mo	—	—	165.00
Add for delivery and pickup, within 15 miles					
One time charge	—	LS	—	—	226.00
Portable job site shacks with lights, power receptacles, locking door and window. Rental per month, based on 6 month rental					
12' x 8' x 8'	—	Mo	—	—	81.90
8' x 8' x 8'	—	Mo	—	—	71.00
Add for typical delivery and pickup, within 15 miles					
One time charge	—	LS	—	—	77.70
Temporary Enclosures Rented chain link fence and accessories. Costs are a one-time charge for up to six months usage on a rental basis. Costs include installation and one trip for removal, and assume level site with truck access along pre-marked fence line. Add for gates and barbed wire as shown. Minimum charge is \$350.					
Chain link fence, 6' high					
Less than 250 feet	—	LF	—	—	3.40
250 to 500 feet	—	LF	—	—	3.29
501 to 750 feet	—	LF	—	—	3.13
751 to 1,000 feet	—	LF	—	—	2.61
Over 1,000 feet	—	LF	—	—	2.26
Add for gates					
6' x 10' single	—	Ea	—	—	203.00
6' x 12' single	—	Ea	—	—	252.00
6' x 15' single	—	Ea	—	—	333.00
6' x 20' double	—	Ea	—	—	381.00
6' x 24' double	—	Ea	—	—	513.00
6' x 30' double	—	Ea	—	—	634.00
Add for barbed wire					
per strand, per linear foot	—	LF	—	—	.17
Contractor furnished items, installed and removed, based on single use and no salvage value					
Railing on stairway, two sides, 2" x 4"	CL@.121	LF	1.14	5.04	6.18
Guardrail at second and higher floors toe rail, mid rail and top rail	CL@.124	LF	7.01	5.17	12.18
Plywood barricade fence					
Bolted to pavement, 8' high	CL@.430	LF	45.70	17.90	63.60
Post in ground, 8' high	CL@.202	LF	38.20	8.42	46.62
8' high with 4' wide sidewalk cover	CL@.643	LF	122.00	26.80	148.80
Cleanup					
Progressive "broom clean" cleanup, per 1,000 SF of floor per cleaning					
Typical cost	CL@.183	MSF	—	7.62	7.62
Final, total floor area (no glass cleaning)	CL@1.65	MSF	—	68.70	68.70
Glass cleaning, per 1,000 square feet of glass cleaned on one side. (Double these figures when both sides are cleaned.) Add the cost of staging or scaffolding when needed					
Cleaning glass with sponge and squeegee	CL@1.34	MSF	16.40	55.80	72.20
Cleaning glass and window trim with solvent, towel, sponge and squeegee	CL@5.55	MSF	20.60	231.00	251.60
Removing paint and concrete splatter from windows and trim by scraping and solvent	CL@15.9	MSF	51.40	662.00	713.40
Mop resilient floor by hand	CL@1.20	MSF	1.88	50.00	51.88

01 General Requirements

	Craft@Hrs	Unit	Material	Labor	Total
Waste Disposal					
Dump fees. Tipping charges for solid waste disposal at the dump or transfer station vary from \$30 to \$120 per ton. For planning purposes, estimate waste disposal at \$75 per ton plus the hauling cost. Call the dump or trash disposal company for actual charges. Typical costs are shown below.					
Dumpster, 3 CY trash bin, emptied weekly	—	Mo	—	—	398.00
Dumpster, 40 CY solid waste bin (lumber, drywall, roofing)					
Hauling cost, per load	—	Ea	—	—	281.00
Add to per load charge, per ton	—	Ton	—	—	68.90
Low-boy, 14 CY solid waste container (asphalt, dirt, masonry, concrete)					
Hauling cost, per load (use 7 CY as maximum load)	—	Ea	—	—	270.00
Add to per load charge, per ton	—	Ton	—	—	68.90
Recycler fees. Recycling construction waste materials can substantially reduce disposal costs. Recycling charges vary from \$95 to \$120 per load, depending on the type material and the size of the load. Call the recycling company for actual charges. Typical recycler fees are shown below. Add the cost for hauling.					
Green waste	—	Ton	—	—	37.10
Asphalt, per load (7 CY)	—	Ea	—	—	117.00
Concrete, masonry or rock, per load (7 CY)	—	Ea	—	—	115.00
Dirt, per load (7 CY)	—	Ea	—	—	111.00
Mixed loads, per load (7 CY)	—	Ea	—	—	120.00

02 Existing Conditions

Paving and Curb Demolition

No salvage of materials. These costs include the cost of loading and hauling to a legal dump within 6 miles. Dump fees are not included. See Waste Disposal. Equipment cost includes one wheel-mounted air compressor, one paving breaker and jackhammer bits, one 55 HP wheel loader with integral backhoe and one 5 CY dump truck. The figures in parentheses give the approximate loose volume of the materials (volume after being demolished). Add the cost of saw cutting, if required. Use \$500.00 as a minimum charge.

	Craft@Hrs	Unit	Material	Labor	Equipment	Total
Demolish bituminous paving, depths to 3" (10 SY per CY)						
Large area, with a wheel loader	C3@.048	SY	—	2.34	1.70	4.04
Strips 24" wide for utility lines	C3@.055	SY	—	2.68	1.95	4.63
Add for jobs under 50 SY	C3@.013	SY	—	.63	.46	1.09
Demolish bituminous curbs, to 12" width (65 LF per CY)						
C3@.035	C3@.035	LF	—	1.70	1.24	2.94
Demolish concrete sidewalk or paving						
4" concrete with no reinforcing (1 CY of waste per 75 SF demolished)	C3@.045	SF	—	2.19	1.59	3.78
4" concrete with mesh but no rebars (1 CY of waste per 65 SF demolished)	C3@.050	SF	—	2.44	1.77	4.21
4" concrete with rebars (1 CY of waste per 55 SF demolished)	C3@.058	SF	—	2.83	2.05	4.88
5" concrete with mesh but no rebars (1 CY of waste per 55 SF demolished)	C3@.063	SF	—	3.07	2.33	5.40
5" concrete with rebars (1 CY of waste per 46 SF demolished)	C3@.073	SF	—	3.56	2.59	6.15
6" concrete with mesh but no rebars (1 CY of waste per 45 SF demolished)	C3@.078	SF	—	3.80	2.76	6.56

02 Existing Conditions

	Craft@Hrs	Unit	Material	Labor	Equipment	Total
6" concrete with rebars (1 CY of waste per 38 SF demolished)	C3@.089	SF	—	4.34	3.15	7.49
8" concrete with mesh but no rebars (1 CY of waste per 32 SF demolished)	C3@.109	SF	—	5.31	3.86	9.17
8" concrete with rebars (1 CY of waste per 27 SF demolished)	C3@.125	SF	—	6.09	4.43	10.52
Concrete over 8" to 12" thick Per CY without rebars (2 CY of waste per 1 CY demolished)	C3@4.60	CY	—	224.00	163.00	387.00
Per CY with rebars (2.4 CY of waste per 1 CY demolished)	C3@5.29	CY	—	258.00	187.00	445.00
Demolish concrete curb Curb and 24" monolithic gutter (7 LF per CY)	C3@.100	LF	—	4.87	3.54	8.41
Planter and batter type curbs, 6" wide (30 LF per CY)	C3@.043	LF	—	2.09	1.52	3.61
Remove pavement markings by water blasting. Use \$100.00 as a minimum charge Water blaster, per hour	—	Hour	—	—	12.50	12.20
4" wide strips	CL@.032	LF	—	1.33	.40	1.73
Per square foot	CL@.098	SF	—	4.08	1.22	5.30

Fencing demolition Equipment includes one 5 CY dump truck. No salvage except as noted. These costs include loading and hauling to a legal dump within 6 miles. Dump fees are not included. See Waste Disposal. Use \$250.00 as a minimum charge.

Remove chain link fence, To 4' high	C4@.030	LF	—	1.30	.46	1.76
5' to 8' high	C4@.055	LF	—	2.38	.85	3.23
Remove and salvage chain link fence, To 8' high	C4@.073	LF	—	3.16	1.13	4.29
Remove and dispose wood fence Picket or board fence to 4' high	C4@.056	LF	—	2.43	.86	3.29
Picket or board fence 5' to 8' high	C4@.080	LF	—	3.47	1.24	4.71
Split rail fence, 2 or 3 rail	C4@.035	LF	—	1.52	.54	2.06
Remove and dispose wood or chain link fence gate To 8' high, including one gate post	C4@.333	LF	—	14.40	5.14	19.54

Highway-type guardrail demolition These costs include loading and hauling to a legal dump within 6 miles. Dump fees are not included. See Waste Disposal. No salvage except as noted. Equipment includes one wheel-mounted air compressor, one paving breaker and jackhammer bits, one 55 HP wheel loader with integral backhoe and one 5 CY dump truck. Use \$500.00 as a minimum charge.

Remove and dispose guardrail	C4@.043	LF	—	1.86	1.52	3.38
Remove guardrail in salvage condition	C4@.074	LF	—	3.21	2.62	5.83
Remove and dispose guardrail posts	C3@.245	Ea	—	11.90	8.68	20.58

Manhole, Piping and Underground Tank Demolition No salvage of materials except as noted. These costs include loading and hauling to a legal dump within 6 miles. Dump fees are not included. See Waste Disposal. Equipment includes one wheel-mounted air compressor, one paving breaker and jackhammer bits, one 55 HP wheel loader with integral backhoe and one 5 CY dump truck. Use \$400.00 as a minimum charge.

Manholes and catch basins, demolition, to 10' deep. Break below collar and plug

Brick	C3@5.16	Ea	—	251.00	176.00	427.00
Masonry	C3@5.33	Ea	—	260.00	183.00	443.00

02 Existing Conditions

	Craft@Hrs	Unit	Material	Labor	Equipment	Total
Precast concrete	C3@6.64	Ea	—	323.00	235.00	558.00
Add for sand fill, any of above	C3@.125	CY	39.00	6.09	4.43	49.52
Frame and cover from manhole or catch basin						
Remove in salvage condition	C3@1.45	Ea	—	70.60	51.40	122.00
Remove and reset	C3@3.99	Ea	—	194.00	141.00	335.00
Fire hydrant demolition						
Remove and dispose	C3@5.57	Ea	—	271.00	197.00	468.00
Break out storm or sewer pipe, non-salvageable. Excavation or backfill not included						
Up to 12" diameter	C3@.114	LF	—	5.55	4.04	9.59
15" to 18"	C3@.134	LF	—	6.53	4.75	11.28
21" to 24"	C3@.154	LF	—	7.50	5.46	12.96
27" to 36"	C3@.202	LF	—	9.84	7.16	17.00
Remove welded steel pipe for salvage. Excavation or backfill not included						
4" diameter or smaller	C3@.111	LF	—	5.41	3.93	9.34
6" to 10" diameter	C3@.202	LF	—	9.84	7.16	17.00
Remove and haul away empty underground liquid storage tanks. (Draining and disposing of hazardous liquid in a tank may require special waste handling equipment.) Cost of draining not included. Includes excavation and backfill to 6' deep.						
50 to 250 gallon tank	C3@4.24	Ea	—	207.00	150.00	357.00
Over 250 to 600 gallon tank	C3@11.7	Ea	—	570.00	415.00	985.00
Over 600 to 1,000 gallon tank	C3@22.4	Ea	—	1,090.00	794.00	1,884.00
Add for sand fill, any of above	C3@.125	CY	39.00	6.09	4.43	49.52

Miscellaneous Sitework Demolition No salvage of materials except as noted. These costs include loading and hauling to a legal dump within 6 miles. Dump fees are not included. See Waste Disposal.

Railroad demolition, siding quantities. Equipment includes one wheel-mounted air compressor, one paving breaker and jackhammer bits, one 55 HP wheel loader with integral backhoe and one 5 CY dump truck

Remove track and ties for scrap	C5@.508	LF	—	23.90	13.50	37.40
Remove and dispose of ballast stone	C5@.111	CY	—	5.21	2.95	8.16
Remove wood ties alone	C5@.143	Ea	—	6.71	3.80	10.51
Remove light standards, flagpoles, playground poles, up to 30' high, including foundations. Equipment includes one wheel-mounted air compressor, one pneumatic breaker and jackhammer bits and one 5 CY dump truck. Use \$400.00 as a minimum charge						
Remove item, in salvage condition	C4@6.24	Ea	—	270.00	148.00	418.00
Remove item, no salvage	C4@.746	Ea	—	32.30	17.70	50.00
Torch cutting steel plate. Equipment is an oxygen-acetylene manual welding and cutting torch with gases, regulator and goggles. Use \$200.00 as a minimum charge						
To 3/8" thick	CL@.073	LF	—	3.04	.56	3.60

Building Demolition Costs for demolishing an entire building. Includes loading and hauling up to 6 miles but no dump fees. See Waste Disposal. Costs are by square foot of floor area based on 8' ceiling height. No salvage value assumed. Figures in parentheses give the approximate "loose" volume of the materials (volume after being demolished).

Light wood-frame structures Up to three stories in height. Based on 2,500 SF job. No basements included.

Estimate each story separately. Equipment includes one 55 HP wheel loader with integral backhoe and one 5 CY dump truck. Use \$3,200.00 as a minimum charge.

First story (8 SF per CY)	C5@.038	SF	—	1.78	.77	2.55
Second story (8 SF per CY)	C5@.053	SF	—	2.49	1.08	3.57
Third story (8 SF per CY)	C5@.070	SF	—	3.29	1.43	4.72

Building demolition with pneumatic tools Equipment includes one wheel-mounted air compressor, three breakers and jackhammer bits, two 55 HP wheel loaders with integral backhoes and two 5 CY dump trucks. Use \$10,000.00 as a minimum charge.

Concrete building (30 SF per CY)	C6@.089	SF	—	4.08	1.79	5.87
----------------------------------	---------	----	---	------	------	------

02 Existing Conditions

	Craft@Hrs	Unit	Material	Labor	Equipment	Total
Reinforced concrete building (20 SF per CY)	C6@.101	SF	—	4.63	2.03	6.66
Masonry building (50 SF per CY)	C6@.074	SF	—	3.40	1.49	4.89

Building demolition with crane and headache ball Equipment includes one wheel-mounted air compressor, one pneumatic paving breaker and jackhammer bits, one 55 HP wheel loader with integral backhoe and backhoe mounted paving breaker, one 15-ton hydraulic crane with headache ball and three 5 CY dump trucks. Use \$10,000.00 as a minimum charge.

Concrete building (30 SF per CY)	C7@.031	SF	—	1.50	1.20	2.70
Reinforced concrete building (20 SF per CY)	C7@.037	SF	—	1.79	1.43	3.22
Masonry building (50 SF per CY)	C7@.026	SF	—	1.26	1.01	2.27

Concrete foundation and footing demolition with D-6 crawler dozer and pneumatic tools. Equipment includes one wheel-mounted air compressor, one pneumatic paving breaker and jackhammer bits, one D-6 crawler dozer with attachments and one 5 CY dump truck. Use \$5,000.00 as a minimum charge.

Non-reinforced concrete (1 CY yields 1.33 loose CY)	C3@1.10	CY	—	53.60	57.50	111.10
Reinforced concrete (1 CY yields 1.66 loose CY)	C3@1.58	CY	—	77.00	82.50	159.50
Chip out concrete using paving breaker No dozer used, (.8 CF yields 1 loose CF)	CL@.203	CF	—	8.46	4.81	13.27

Gutting a building Interior finishes stripped back to the structural walls. Building structure to remain. No allowance for salvage value. These costs include loading and hauling up to 6 miles. Dump fees are not included. See Waste Disposal. Costs shown are per square foot of floor area based on 8' ceiling height. Costs will be about 50% less if a small tractor can be used and up to 25% higher if debris must be carried to ground level in an elevator. Equipment includes one air compressor, two pneumatic breakers with jackhammer bits and one 5 CY dump truck. Figures in parentheses give the approximate "loose" volume of the materials (volume after being demolished). Use \$3,000.00 as a minimum charge.

Residential buildings (125 SF per CY)	C4@.110	SF	—	4.77	2.61	7.38
Commercial buildings (140 SF per CY)	C4@.100	SF	—	4.33	2.37	6.70

Partition wall demolition Building structure to remain. No allowance for salvage value. Dump fees are not included. See Waste Disposal. Costs shown are per square foot of wall removed (as measured on one side). Knock down with pneumatic jackhammers and pile adjacent to site but no removal. Equipment includes one air compressor and two pneumatic breakers with jackhammer bits. Figures in parentheses give the approximate "loose" volume of the materials (volume after being demolished). Use \$350.00 as a minimum charge.

Brick or block partition demolition						
4" thick partition (60 SF per CY)	CL@.040	SF	—	1.67	1.25	2.92
8" thick partition (30 SF per CY)	CL@.057	SF	—	2.37	1.78	4.15
12" thick partition (20 SF per CY)	CL@.073	SF	—	3.04	2.28	5.32
Concrete partition demolition						
Non-reinforced (18 CF per CY)	CL@.273	CF	—	11.40	8.54	19.94
Reinforced (20 CF per CY)	CL@.363	CF	—	15.10	11.40	26.50
Knock down with hand tools and pile adjacent to site but no removal.						
Stud partition demolition (typically 75 to 100 SF per CY)						
Gypsum or terra cotta on metal lath	CL@.027	SF	—	1.12	—	1.12
Drywall on metal or wood studs	CL@.028	SF	—	1.17	—	1.17
Plaster on metal studs	CL@.026	SF	—	1.08	—	1.08

Ceiling demolition Building structure to remain. No allowance for salvage value. Dump fees are not included. See Waste Disposal. Costs shown are per square foot of ceiling (as measured on one side). Figures in parentheses give the approximate "loose" volume of the materials (volume after being demolished). Use \$300.00 as a minimum charge. Knock down with hand tools to remove ceiling finish on framing at heights to 9'.

02 Existing Conditions

	Craft@Hrs	Unit	Material	Labor	Equipment	Total
Plaster ceiling (typically 175 to 200 SF per CY)						
Including lath and furring	CL@.025	SF	—	1.04	—	1.04
Including suspended grid	CL@.020	SF	—	.83	—	.83
Acoustic tile ceiling (typically 200 to 250 SF per CY)						
Including suspended grid	CL@.010	SF	—	.42	—	.42
Including grid in salvage condition	CL@.019	SF	—	.79	—	.79
Including strip furring	CL@.014	SF	—	.58	—	.58
Tile glued to ceiling	CL@.015	SF	—	.62	—	.62
Drywall ceiling (typically 250 to 300 SF per CY)						
Nailed or attached with screws						
to joists	CL@.012	SF	—	.50	—	.50
Including strip furring	CL@.023	SF	—	.96	—	.96

Roof demolition Building structure to remain. No allowance for salvage value. Add the cost of dump fees from the waste disposal section. Costs shown are per square foot of area removed (as measured on one side).

Roof surface removal, using hand tools. Figures in parentheses give the approximate "loose" volume of the materials (volume after being demolished). Use \$900.00 as a minimum charge.

Asphalt shingles (2.50 Sq per CY)	CL@.850	Sq	—	35.40	—	35.40
Built-up roofing, including sheathing and gravel (1.25 Sq per CY)	CL@2.91	Sq	—	121.00	—	121.00
Clay or concrete tile (.70 Sq per CY)	CL@1.03	Sq	—	42.90	—	42.90
Concrete plank, no covering (.80 Sq per CY)	CL@1.10	Sq	—	45.80	—	45.80
Gypsum plank, no covering (.70 Sq per CY)	CL@.820	Sq	—	34.20	—	34.20
Metal deck, no covering (.50 Sq per CY)	CL@2.27	Sq	—	94.60	—	94.60
Wood shingles or flashing (1.66 Sq per CY)	CL@.756	Sq	—	31.50	—	31.50
Remove gravel stop	CL@.070	LF	—	2.92	—	2.92

Floor slab demolition Using pneumatic jackhammers. Piled adjacent to site but no removal. Equipment includes one air compressor and two pneumatic breakers with jackhammer bits. Use \$350.00 as a minimum charge.

Slab on grade, 4" to 6" thick, reinforced						
With wire mesh (55 SF per CY)	CL@.057	SF	—	2.37	1.78	4.15
With number 4 bars (45 SF per CY)	CL@.063	SF	—	2.62	1.97	4.59
Slab, suspended, 6" to 8" thick, free fall (35 SF per CY)	CL@.092	SF	—	3.83	2.88	6.71
Slab fill, lightweight concrete fill						
On metal deck (45 SF per CY)	CL@.029	SF	—	1.21	.91	2.12
Topping, insulating (150 SF per CY)	CL@.023	SF	—	.96	.72	1.68

Floor covering demolition Using hand tools. Debris piled adjacent to site but no removal. Figures in parentheses give the approximate "loose" volume of the materials (volume after being demolished). Use \$350.00 as a minimum charge.

Ceramic or quarry tile, brick (200 SF per CY)	CL@.029	SF	—	1.21	—	1.21
Resilient materials only (270 SF per CY)	CL@.018	SF	—	.75	—	.75
Terrazzo tile (225 SF per CY)	CL@.032	SF	—	1.33	—	1.33

02 Existing Conditions

	Craft@Hrs	Unit	Material	Labor	Equipment	Total
Wood block floor, laid in mastic (200 SF per CY)	CL@.051	SF	—	2.12	—	2.12
Wood, residential strip floor (225 SF per CY)	CL@.032	SF	—	1.33	—	1.33

Cutting openings in frame walls Using hand tools. Cost per square foot of wall measured on one face.

Metal stud wall with stucco or plaster	CL@.094	SF	—	3.92	—	3.92
Wood stud wall with drywall	CL@.051	SF	—	2.12	—	2.12
Dust control partitions, 6 mil plastic	C8@.011	SF	.10	.52	—	.62

Debris removal Break demolition debris into manageable size with hand tools, load into a 5 CF wheelbarrow, move to chute and dump. Costs shown are per cubic foot of material dumped.

Wheelbarrow, 50' to trash chute and dump	CL@.018	CF	—	.75	—	.75
Wheelbarrow, 100' to trash chute and dump	CL@.022	CF	—	.92	—	.92
Wheelbarrow, 50' to elevator, descend 10 floors to trash chute and dump	CL@.024	CF	—	1.00	—	1.00
Trash chutes. Prefabricated steel chute installed and removed in a multi-story building. One-time charge for up to six-month's usage. Use 50 LF as minimum charge						
18" diameter	—	LS	—	—	—	1,160.00
36" diameter	—	LS	—	—	—	1,735.00

Load demolition debris on a truck and haul 6 miles to a dump site. Equipment includes one 5 CY dump truck and one 1 CY articulating wheel loader. Includes truck cost but dump fees are not included. See Waste Disposal. Per cubic yard of debris.

Truck loaded by hand	C4@.828	CY	—	35.90	12.80	48.70
Truck loaded using a wheel loader	C5@.367	CY	—	17.20	8.17	25.37

Removal of interior items Using hand tools. Items removed in salvageable condition do not include an allowance for salvage value. Figures in parentheses give the approximate "loose" volume of the materials (volume after being demolished.) Removal in non-salvageable condition (demolished) except as noted.

Hollow metal door and frame in a masonry wall. (2 doors per CY)

Single door to 4' x 7'	CL@1.00	Ea	—	41.70	—	41.70
Two doors, per opening to 8' x 7'	CL@1.50	Ea	—	62.50	—	62.50

Wood door and frame in a wood-frame wall (2 doors per CY)

Single door to 4' x 7'	CL@.500	Ea	—	20.80	—	20.80
Two doors, per opening to 8' x 7'	CL@.750	Ea	—	31.20	—	31.20

Remove door and frame in masonry wall, salvage condition

Hollow metal door to 4' x 7'	C8@2.00	Ea	—	95.20	—	95.20
Wood door to 4' x 7'	C8@1.00	Ea	—	47.60	—	47.60

Frame for resilient mat, metal

Per SF of mat area	C8@.054	SF	—	2.57	—	2.57
--------------------	---------	----	---	------	---	------

Lockers, metal 12" W, 60" H, 15" D	C8@.500	Ea	—	23.80	—	23.80
------------------------------------	---------	----	---	-------	---	-------

Sink and soap dispenser, wall-hung	C8@.500	Ea	—	23.80	—	23.80
------------------------------------	---------	----	---	-------	---	-------

Toilet partitions, wood or metal Per partition	C8@.750	Ea	—	35.70	—	35.70
---	---------	----	---	-------	---	-------

Urinal screens, wood or metal Per partition	C8@.500	Ea	—	23.80	—	23.80
--	---------	----	---	-------	---	-------

Window and frame, wood or metal	C8@.076	SF	—	3.62	—	3.62
---------------------------------	---------	----	---	------	---	------

Remove and reset airlock doors	C8@5.56	Ea	—	265.00	—	265.00
--------------------------------	---------	----	---	--------	---	--------

02 Existing Conditions

	Craft@Hrs	Unit	Material	Labor	Equipment	Total
Structure Moving Up to 5 mile haul, not including new foundation costs, utility hookup or finishing. These figures assume two stories maximum, no obstruction from trees or utility lines and that adequate right of way is available. Fees and charges imposed by government are not included. Costs shown are per SF of total floor area. Equipment cost includes one tow-truck equipped with dollies, jacks, support beams and hand tools. For estimating purpose, use 1,000 SF as a minimum job charge.						
Concrete or masonry structures, 12" maximum thick walls or floors						
1,000 to 2,000 SF	C1@.168	SF	—	7.17	13.60	20.77
2,000 to 4,000 SF	C1@.149	SF	—	6.36	12.10	18.46
Wood frame						
1,000 to 2,000 SF	C1@.142	SF	—	6.06	11.50	17.56
2,000 to 4,000 SF	C1@.131	SF	—	5.59	10.60	16.19
Steel frame						
1,000 to 2,000 SF	C1@.215	SF	—	9.17	17.40	26.57
2,000 to 4,000 SF	C1@.199	SF	—	8.49	16.10	24.59
Asbestos Hazard Surveys Building inspection, hazard identification, sampling and ranking of asbestos risk.						
Asbestos hazard survey and sample collection (10,000 SF per hour)						
4 hour minimum	—	Hour	—	—	—	91.80
Sample analysis (usually one sample per 1,000 SF)						
10 sample minimum	—	Ea	—	—	—	56.10
Report writing (per 1,000 SF of floor)						
\$200 minimum	—	MSF	—	—	—	29.00
Asbestos Removal, Subcontract Typical costs including site preparation, monitoring, equipment, and removal of waste. Disposal of hazardous waste materials vary widely, consult your local waste disposal facility concerning prices and procedures.						
Ceiling insulation in containment structure						
500 to 5,000 SF job	—	SF	—	—	—	41.00
5,000 to 20,000 SF job	—	SF	—	—	—	29.00
Pipe insulation in containment structure						
100 to 1,000 LF of 6" pipe	—	LF	—	—	—	72.30
1,000 to 3,000 LF of 6" pipe	—	LF	—	—	—	46.30
Pipe insulation using glove bags						
100 to 1,000 LF of 6" pipe	—	LF	—	—	—	61.50
1,000 to 3,000 LF of 6" pipe	—	LF	—	—	—	46.30

03 Concrete

Excavation for Concrete Work Add the cost of placing and removing shoring if required. Typical soil conditions.						
Batterboards, lay out for footings,						
per corner	C8@1.24	Ea	14.30	59.00	—	73.30
Trenching with a 1/2 CY utility backhoe/loader, small jobs, good soil conditions, no backfill included						
18" x 24" depth,						
.111 CY per LF (135 LF/Hr)	S1@.015	LF	—	.75	.34	1.09
24" x 36" depth,						
.222 CY per LF (68 LF/Hr)	S1@.029	LF	—	1.44	.66	2.10
36" x 48" depth,						
.444 CY per LF (34 LF/Hr)	S1@.059	LF	—	2.93	1.33	4.26
48" x 60" depth,						
.741 CY per LF (20 LF/Hr)	S1@.099	LF	—	4.92	2.24	7.16
Per cubic yard,						
15 CY per hour	S1@.133	CY	—	6.61	3.01	9.62

03 Concrete

	Craft@Hrs	Unit	Material	Labor	Equipment	Total
Hand labor						
Clearing trench shoulders of obstructions	CL@.017	LF	—	.69	—	.69
Hard pan or rock outcropping Breaking and stacking	CL@3.23	CY	—	135.00	—	135.00
Column pads and small piers, average soil	CL@1.32	CY	—	55.00	—	55.00
Backfilling against foundations, no import or export of materials Hand, including hand tamp	CL@.860	CY	—	35.80	—	35.80
Backfill with a 1/2 CY utility backhoe/loader Minimum compaction, wheel-rolled	S1@.055	CY	—	2.74	1.24	3.98
Backfill with 1/2 CY utility backhoe/loader, 150 CFM compressor & pneumatic tamper Spec grade compaction	S1@.141	CY	—	7.01	5.78	12.79
Disposal of excess backfill material with a 1/2 CY backhoe, no compaction						
Spot spread, 100' haul	S1@.034	CY	—	1.69	.77	2.46
Area spread, 4" deep (covers 81 SF per CY)	S1@.054	CY	—	2.69	1.22	3.91
Grading for slabs						
Using a D-4 crawler tractor with dozer blade (1000 SF per hour)	S1@.001	SF	—	.05	.03	.08
Fine grading, by hand, light to medium soil (165 to 170 SF per hour)	CL@.006	SF	—	.25	—	.25
Capillary fill, one CY covers 81 SF at 4" deep						
4", hand graded and rolled, small job	CL@.014	SF	.48	.58	—	1.06
4", machine graded and rolled, larger job	S1@.006	SF	.48	.30	.19	.97
Add for each extra 1" hand graded	CL@.004	SF	.12	.17	—	.29
Add for each extra 1" machine graded	S1@.001	SF	.12	.05	.03	.20
Sand fill, 1 CY covers 162 SF at 2" deep						
2" sand cushion, hand spread, 1 throw	CL@.003	SF	.48	.12	—	.60
Add for each additional 1"	CL@.002	SF	.12	.08	—	.20
Waterproof membrane, polyethylene, over sand bed, including 15% lap and waste						
.004" (4 mil) clear or black	CL@.001	SF	.08	.04	—	.12
.006" (6 mil) clear or black	CL@.001	SF	.10	.04	—	.14

Formwork for Concrete Labor costs include the time needed to prepare formwork sketches at the job site, measure for the forms, fabricate, erect, align, brace, strip, clean and stack the forms. Costs for reinforcing and concrete are not included. Multiple use of forms shows the cost per use when a form is used several times on the same job without being totally disassembled or discarded. Normal cleaning and repairs are included in the labor cost on lines that show multiple use of forms. Costs will be higher if plans are not detailed enough to identify the work to be performed. No salvage value is assumed except as noted. Costs listed are per square foot of form in contact with the concrete (SFCA). These costs assume Standard and Better lumber price of \$851 per MBF and \$1,310 per MSF for 3/4" plyform before waste allowance. For more detailed coverage of concrete formwork, see *National Concrete & Masonry Estimator*, <https://craftsman-book.com/national-estimator-cloud>.

	Craft@Hrs	Unit	Material	Labor	Total
Wall footing, grade beam or tie beam forms These figures assume nails, stakes and form oil costing \$.25 per square foot and 2.5 board feet of lumber are used for each square foot of form in contact with the concrete (SFCA). To calculate the quantity of formwork required, multiply the depth of footing in feet by the length of footing in feet. Then double the results if two sides will be formed. For scheduling purposes, estimate that a crew of 5 can lay out, fabricate and erect 600 to 700 SF of footing, grade beam or tie beam forms in an 8-hour day.					
1 use	F5@.070	SFCA	3.37	3.41	6.78
3 uses	F5@.050	SFCA	1.81	2.44	4.25
5 uses	F5@.040	SFCA	1.50	1.95	3.45
Add for stepped footings	F5@.028	SFCA	.83	1.37	2.20
Add for keyed joint, 1 use	F5@.020	LF	1.50	.98	2.48

03 Concrete

	Craft@Hrs	Unit	Material	Labor	Total
Reinforcing bar supports for footing, grade beam and tie beam forms. Bars suspended from 2" x 4" lumber, including stakes. Based on .86 BF of lumber per LF					
1 use	F5@.060	LF	1.32	2.93	4.25
3 uses	F5@.050	LF	.79	2.44	3.23
5 uses	F5@.040	LF	.68	1.95	2.63
Integral starter wall forms (stem walls) formed monolithic with footings, heights up to 4'0", with 3 BF of lumber per SFCA plus an allowance of \$0.25 for nails, stakes and form oil					
1 use	F5@.100	SFCA	3.99	4.88	8.87
3 uses	F5@.075	SFCA	2.12	3.66	5.78
5 uses	F5@.067	SFCA	1.75	3.27	5.02
Bulkheads or pour-stops. When integral starter walls are formed, forms will usually be required at the ends of each wall or footing. These are usually called bulkheads or pour-stops. These figures assume the use of 1.1 SF of 3/4" plyform per SFCA plus an allowance of \$0.25 per SFCA for nails, stakes and bracing					
1 use	F5@.150	SFCA	2.87	7.32	10.19
3 uses	F5@.120	SFCA	1.56	5.85	7.41
5 uses	F5@.100	SFCA	1.30	4.88	6.18
Column footing or pile cap forms These figures include nails, stakes and form oil and 3.5 board feet of lumber for each square foot of form in contact with the concrete. For scheduling purposes, estimate that a crew of 5 can lay out, fabricate and erect 500 to 600 SF of square or rectangular footing forms in an 8-hour day or 350 to 450 SF of octagonal, hexagonal or triangular footing forms in an 8-hour day.					
Square or rectangular column forms					
1 use	F5@.090	SFCA	4.61	4.39	9.00
3 uses	F5@.070	SFCA	2.43	3.41	5.84
5 uses	F5@.060	SFCA	2.00	2.93	4.93
Octagonal, hexagonal or triangular forms					
1 use	F5@.117	SFCA	4.61	5.71	10.32
3 uses	F5@.091	SFCA	2.43	4.44	6.87
5 uses	F5@.078	SFCA	2.00	3.80	5.80
Reinforcing bar supports for column forms. Bars suspended from 2" x 4" lumber, including stakes. Based on .86 BF of lumber per LF					
1 use	F5@.060	LF	1.07	2.93	4.00
Anchor bolt templates or dowel supports for column forms. Includes cost of nails, stakes, bracing, and form oil and 1.1 SF of 3/4" plyform for each SF of column base or dowel support. No anchor bolts included					
1 use	F5@.150	SF	2.87	7.32	10.19
3 uses	F5@.100	SF	1.56	4.88	6.44
5 uses	F5@.090	SF	1.30	4.39	5.69
Slab-on-grade forms These costs assume nails, stakes, form oil, and accessories are used for each board foot of lumber. Note that costs listed below are per linear foot (LF) of form. Figures in parentheses show the average square feet of contact area (SFCA) per linear foot of form. Use this figure to convert costs and man hours per linear foot to costs and manhours per square foot. For scheduling purposes, estimate that a crew of 5 will lay out, fabricate and erect the following quantities of slab-on-grade edge forms in an 8-hour day:					
Slabs to 6" high at 615 to 720 LF.			Slabs over 6" to 12" high at 450 to 500 LF		
Slabs over 12" to 24" high at 320 to 350 LF.			Slabs over 24" to 36" high, 240 to 260 LF		
Edge forms to 6" high, 1.5 BF per LF of form (.5 SFCA per LF)					
1 use	F5@.065	LF	2.12	3.17	5.29
3 uses	F5@.061	LF	1.19	2.98	4.17
5 uses	F5@.055	LF	1.00	2.68	3.68
Edge forms over 6" high to 12" high, 2.25 BF per LF of form (average .75 SFCA per LF)					
1 use	F5@.090	LF	3.06	4.39	7.45
3 uses	F5@.086	LF	1.65	4.20	5.85
5 uses	F5@.080	LF	1.37	3.90	5.27

03 Concrete

	Craft@Hrs	Unit	Material	Labor	Total
Edge forms over 12" high to 24" high, 4.5 BF per LF of form (average 1.5 SFCA per LF)					
1 use	F5@.124	LF	5.86	6.05	11.91
3 uses	F5@.119	LF	3.06	5.80	8.86
5 uses	F5@.115	LF	2.49	5.61	8.10
Edge forms over 24" high to 36" high, 7.5 BF per LF of forms (average 2.5 SFCA per LF)					
1 use	F5@.166	LF	9.60	8.10	17.70
3 uses	F5@.160	LF	4.93	7.80	12.73
5 uses	F5@.155	LF	3.99	7.56	11.55
Add for 2" x 2" tapered keyed joint, one-piece, .38 BF per LF					
1 use	F5@.044	LF	.47	2.15	2.62
3 uses	F5@.040	LF	.24	1.95	2.19
5 uses	F5@.035	LF	.19	1.71	1.90
Blockout and slab depression forms. Figure the linear feet required Use the linear foot costs for slab edge forms for the appropriate height and then add per linear foot					
Blockouts	F5@.030	LF	1.22	1.46	2.68
Wall forms Formwork over 6' high includes an allowance for a work platform and handrail built on one side of the form for use by the concrete placing crew.					
Heights to 4', includes 1.1 SF of plyform, 1.5 BF of lumber and allowance for nails, ties and oil per SFCA					
1 use	F5@.119	SFCA	4.75	5.80	10.55
3 uses	F5@.080	SFCA	2.50	3.90	6.40
5 uses	F5@.069	SFCA	2.05	3.37	5.42
Add for 1 side battered	F5@.016	SFCA	.47	.78	1.25
Add for 2 sides battered	F5@.024	SFCA	.95	1.17	2.12
Heights over 4' to 6', includes 1.1 SF of plyform, 2.0 BF of lumber and allowance for nails, ties and oil.					
1 use	F5@.140	SFCA	5.37	6.83	12.20
3 uses	F5@.100	SFCA	2.81	4.88	7.69
5 uses	F5@.080	SFCA	2.30	3.90	6.20
Add for 1 side battered	F5@.016	SFCA	.54	.78	1.32
Add for 2 sides battered	F5@.024	SFCA	1.07	1.17	2.24
Heights over 6' to 12', includes 1.2 SF of plyform, 2.5 BF of lumber and allowance for nails, ties and oil.					
1 use	F5@.160	SFCA	6.23	7.80	14.03
3 uses	F5@.110	SFCA	3.24	5.37	8.61
5 uses	F5@.100	SFCA	2.64	4.88	7.52
Add for 1 side battered	F5@.016	SFCA	.62	.78	1.40
Add for 2 sides battered	F5@.024	SFCA	1.25	1.17	2.42
Heights over 12' to 16', includes 1.2 SF of plyform, 3.0 BF of lumber and allowance for nails, ties and oil.					
1 use	F5@.180	SFCA	6.85	8.78	15.63
3 uses	F5@.130	SFCA	3.55	6.34	9.89
5 uses	F5@.110	SFCA	2.89	5.37	8.26
Add for 1 side battered	F5@.016	SFCA	.69	.78	1.47
Add for 2 sides battered	F5@.024	SFCA	1.37	1.17	2.54
Heights over 16', includes 1.3 SF of plyform, 3.5 BF of lumber and allowance for nails, ties and oil.					
1 use	F5@.199	SFCA	7.72	9.71	17.43
3 uses	F5@.140	SFCA	3.98	6.83	10.81
5 uses	F5@.119	SFCA	3.24	5.80	9.04
Add for 1 side battered	F5@.016	SFCA	.77	.78	1.55
Add for 2 sides battered	F5@.024	SFCA	1.54	1.17	2.71
Architectural form liner for wall forms					
Low cost liners	F5@.020	SFCA	3.37	.98	4.35
Average cost liners	F5@.100	SFCA	5.19	4.88	10.07

03 Concrete

	Craft@Hrs	Unit	Material	Labor	Total
Reveal strips 1" deep by 2" wide, one-piece, wood.					
1 use	F5@.069	LF	.23	3.37	3.60
3 uses	F5@.050	LF	.12	2.44	2.56
5 uses	F5@.020	LF	.10	.98	1.08
Blockouts for openings. Form area is the opening perimeter times the depth. These figures assume that nails and form oil costing \$.25 per square foot, 1.2 SF of plyform and .5 board feet of lumber are used per SF of form.					
Blockouts usually can be used only once.					
1 use	F5@.250	SF	4.19	12.20	16.39
Bulkheads or pour-stops. These costs assume that nails, form oil and accessories, 1.1 SF of plyform and 1 board foot of lumber are used per SF of form.					
1 use	F5@.220	SF	4.12	10.70	14.82
3 uses	F5@.149	SF	2.19	7.27	9.46
5 uses	F5@.130	SF	1.80	6.34	8.14
Add for keyed wall joint, two-piece, tapered, 1.2 BF per SF.					
1 use	F5@.100	SF	1.75	4.88	6.63
3 uses	F5@.069	SF	1.00	3.37	4.37
5 uses	F5@.061	SF	.85	2.98	3.83
Curved wall forms					
Smooth radius, add to straight wall cost	F5@.032	SFCA	1.56	1.56	3.12
8' chord sections, add to straight wall cost	F5@.032	SFCA	.93	1.56	2.49
Haunches or ledges. Area is the width of the ledge times the length. These costs assume nails, form oil and accessories, 2 SF of plyform, and .5 board foot of lumber are used per SF of ledge.					
1 use	F5@.300	SF	5.65	14.60	20.25
3 uses	F5@.210	SF	2.95	10.20	13.15
5 uses	F5@.180	SF	2.41	8.78	11.19
Steel-framed plywood forms Rented steel-framed plywood forms can reduce forming costs on many jobs. Where rented forms are used 3 times in a month, use the wall-forming costs shown for 3 uses at the appropriate height but deduct 25% from the material cost and 50% from the labor manhours and labor costs. Savings will be smaller where layouts change from one use to the next, when form penetrations must be made and repaired before returning a form, where form delivery costs are high, and where non-standard form sizes are needed. For more detailed coverage of steel-framed plywood forms, see <i>National Concrete & Masonry Estimator</i> , https://craftsman-book.com/national-estimator-cloud .					
Column forms for square or rectangular columns Quantities in parentheses show the cross-section area of a square column. When estimating a rectangular column, use the costs for the square column with closest cross-section area. For scheduling purposes estimate that a crew of 5 can lay out, fabricate and erect about 550 to 600 SFCA of square or rectangular column forms in an 8-hour day.					
Up to 12" x 12" (144 square inches), using nails, snap ties, oil and column clamps with 1.15 SF of plyform and 2 BF of lumber per SFCA					
1 use	F5@.130	SFCA	5.49	6.34	11.83
3 uses	F5@.090	SFCA	2.87	4.39	7.26
5 uses	F5@.080	SFCA	2.35	3.90	6.25
Over 12" x 12" to 16" x 16" (256 square inches), using nails, snap ties, oil and column clamps, with 1.125 SF of plyform and 2.1 BF of lumber per SFCA					
1 use	F5@.100	SFCA	5.55	4.88	10.43
3 uses	F5@.069	SFCA	2.90	3.37	6.27
5 uses	F5@.061	SFCA	2.37	2.98	5.35
Over 16" x 16" to 20" x 20" (400 square inches), using nails, snap ties, oil and column clamps, with 1.1 SF of plyform and 2.2 BF of lumber per SFCA					
1 use	F5@.080	SFCA	5.62	3.90	9.52
3 uses	F5@.061	SFCA	2.93	2.98	5.91
5 uses	F5@.050	SFCA	2.40	2.44	4.84

03 Concrete

	Craft@Hrs	Unit	Material	Labor	Total
Over 20" x 20" to 24" x 24" (576 square inches), using nails, snap ties, oil and column clamps, with 1.1 SF of plyform and 2.4 BF of lumber per SFCA					
1 use	F5@.069	SFCA	5.87	3.37	9.24
3 uses	F5@.050	SFCA	3.06	2.44	5.50
5 uses	F5@.040	SFCA	2.50	1.95	4.45
Over 24" x 24" to 30" x 30" (900 square inches), using nails, snap ties, oil and column clamps, with 1.1 SF of plyform and 2.4 BF of lumber per SFCA					
1 use	F5@.061	SFCA	5.87	2.98	8.85
3 uses	F5@.040	SFCA	3.06	1.95	5.01
5 uses	F5@.031	SFCA	2.50	1.51	4.01
Over 30" x 30" to 36" x 36" (1,296 square inches), using nails, snap ties, oil and column clamps, with 1.1 SF of plyform and 2.4 BF of lumber per SFCA					
1 use	F5@.050	SFCA	5.87	2.44	8.31
3 uses	F5@.040	SFCA	3.06	1.95	5.01
5 uses	F5@.031	SFCA	2.50	1.51	4.01
Over 36" x 36" to 48" x 48" (2,304 square inches), using nails, snap ties, oil and column clamps, with 1.1 SF of plyform and 2.5 BF of lumber per SFCA					
1 use	F5@.040	SFCA	5.99	1.95	7.94
3 uses	F5@.031	SFCA	3.12	1.51	4.63
5 uses	F5@.020	SFCA	2.70	.98	3.68

Column capitals for square columns Capital forms for square columns usually have four symmetrical sides. Length and width at the top of the capital are usually twice the length and width at the bottom of the capital. Height is usually the same as the width at the capital base. These costs assume capitals installed not over 12' above floor level, use of nails, form oil, shores and accessories with 1.5 SF of plyform and 2 BF of lumber per SF of contact area (SFCA). Complexity of these forms usually makes more than 3 uses impractical. For scheduling purposes estimate that a crew of 5 can lay out, fabricate and erect the following quantities of capital formwork in an 8-hour day:

70 to 80 SF for 12" to 16" columns	90 to 100 SF for 20" to 24" columns				
110 to 120 SF for 30" to 36" columns	160 to 200 SF for 48" columns				
Up to 12" x 12" column, 6.0 SFCA					
1 use of forms	F5@4.01	Ea	37.90	196.00	233.90
3 uses of forms	F5@3.00	Ea	19.00	146.00	165.00
Over 12" x 12" to 16" x 16" column, 10.7 SFCA					
1 use of forms	F5@6.00	Ea	67.70	293.00	360.70
3 uses of forms	F5@4.01	Ea	33.80	196.00	229.80
Over 16" x 16" to 20" x 20" column, 16.6 SFCA					
1 use of forms	F5@8.31	Ea	105.00	405.00	510.00
3 uses of forms	F5@6.00	Ea	52.50	293.00	345.50
Over 20" x 20" to 24" x 24" column, 24.0 SFCA					
1 use of forms	F5@12.0	Ea	152.00	585.00	737.00
3 uses of forms	F5@9.00	Ea	75.90	439.00	514.90
Over 24" x 24" to 30" x 30" column, 37.5 SFCA					
1 use of forms	F5@16.0	Ea	237.00	780.00	1,017.00
3 uses of forms	F5@12.0	Ea	119.00	585.00	704.00
Over 30" x 30" to 36" x 36" column, 54.0 SFCA					
1 use of forms	F5@20.0	Ea	341.00	976.00	1,317.00
3 uses of forms	F5@16.0	Ea	171.00	780.00	951.00
Over 36" x 36" to 48" x 48", 96.0 SFCA					
1 use of forms	F5@24.0	Ea	607.00	1,170.00	1,777.00
3 uses of forms	F5@18.0	Ea	304.00	878.00	1,182.00

03 Concrete

Craft@Hrs Unit Material Labor Total

Column forms for round columns Use the costs below to estimate round fiber tube forms (Sonotube is one manufacturer). Add the cost of column footings or foundations. These forms are peeled off when the concrete has cured. Costs shown include setting, aligning, bracing and stripping and assume that bracing and collars at top and bottom can be used 3 times. Column forms over 12'0" long will cost more per linear foot. Costs are per linear foot for standard weight column forms. Plastic lined forms have one vertical seam. For scheduling purposes, estimate that a crew of 5 can lay out, erect and brace the following quantities of 10' to 12' high round fiber tube forms in an 8-hour day: twenty 8" to 12" diameter columns; sixteen 14" to 20" columns and twelve 24" to 48" columns. For more detailed coverage of round column forms, see *National Concrete & Masonry Estimator*, <https://craftsman-book.com/national-estimator-cloud>.

Bracing per LF (add to each cost below)

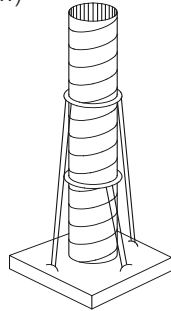

8" spiral-type	F5@.166	LF	1.28	—	1.28
10" spiral-type	F5@.182	LF	1.78	8.10	9.88
12" spiral-type	F5@.207	LF	2.15	8.88	11.03
14" spiral-type	F5@.224	LF	2.67	10.10	12.77
16" spiral-type	F5@.224	LF	3.56	10.90	14.46
20" spiral-type	F5@.232	LF	4.09	11.30	15.39
24" spiral-type	F5@.250	LF	4.98	12.20	17.18
30" spiral-type	F5@.275	LF	6.22	13.40	19.62
36" spiral-type	F5@.289	LF	8.09	14.10	22.19
48" spiral-type	F5@.308	LF	11.40	15.00	26.40
8" heavy-duty, water resistant	F5@.334	LF	14.20	16.30	30.50
10" heavy-duty, water resistant	F5@.166	LF	2.49	8.10	10.59
12" heavy-duty, water resistant	F5@.177	LF	2.96	8.63	11.59
14" heavy-duty, water resistant	F5@.207	LF	3.72	10.10	13.82
16" heavy-duty, water resistant	F5@.224	LF	5.41	10.90	16.31
20" heavy-duty, water resistant	F5@.232	LF	5.94	11.30	17.24
24" heavy-duty, water resistant	F5@.250	LF	8.80	12.20	21.00
30" heavy-duty, water resistant	F5@.275	LF	12.10	13.40	25.50
36" heavy-duty, water resistant	F5@.289	LF	17.20	14.10	31.30
48" heavy-duty, water resistant	F5@.308	LF	21.70	15.00	36.70
	F5@.334	LF	41.10	16.30	57.40

Column capitals for round columns

Use these figures to estimate costs for rented prefabricated steel conical-shaped capital forms. Costs assume a minimum rental period of 1 month and include an allowance for nails and form oil. Labor shown assumes the capital will be supported from the deck formwork above the capital and includes laying out and cutting the hole in the deck to receive the capital. Capital bottom diameter is sized to fit into the column tube form. The column form size (diameter) does not significantly affect the capital form rental cost. Dimensions shown below are the top diameter. Form weights are shown in parentheses. Only 3 uses of these forms are usually possible in a 30-day period. Setting forms and installing reinforcing steel takes one day, concrete placing takes another day, curing requires 7 to 10 days, removing and cleaning forms takes another day. For scheduling purposes estimate that a crew of 5 can lay out, cut openings in floor deck formwork and install an average of 8 or 9 round column capital forms in an 8-hour day.

3'6" (100 pounds) 1 use	F5@4.01	Ea	274.00	196.00	470.00
3'6" (100 pounds) 3 uses	F5@4.01	Ea	91.30	196.00	287.30
4'0" (125 pounds) 1 use	F5@4.01	Ea	295.00	196.00	491.00
4'0" (125 pounds) 3 uses	F5@4.01	Ea	98.70	196.00	294.70
4'6" (150 pounds) 1 use	F5@4.30	Ea	306.00	210.00	516.00
4'6" (150 pounds) 3 uses	F5@4.30	Ea	102.00	210.00	312.00
5'0" (175 pounds) 1 use	F5@4.51	Ea	323.00	220.00	543.00
5'0" (175 pounds) 3 uses	F5@4.51	Ea	115.00	220.00	335.00
5'6" (200 pounds) 1 use	F5@4.51	Ea	370.00	220.00	590.00
5'6" (200 pounds) 3 uses	F5@4.51	Ea	123.00	220.00	343.00
6'0" (225 pounds) 1 use	F5@4.70	Ea	386.00	229.00	615.00
6'0" (225 pounds) 3 uses	F5@4.70	Ea	122.00	229.00	351.00

03 Concrete

Craft@Hrs Unit Material Labor Total

Beam and girder forms Using nails, snap ties and oil, 1.3 SF of 3/4" plyform and 2.1 BF of lumber per SFCA. For scheduling purposes, estimate that a crew of 5 can lay out, fabricate and erect 250 to 300 SF of beam and girder forms in an 8-hour day. For more detailed coverage of beam and girder forms, see *National Concrete & Masonry Estimator*, <https://craftsman-book.com/national-estimator-cloud>.

1 use	F5@.149	SFCA	5.97	7.20	10.74
3 uses	F5@.141	SFCA	3.11	6.88	9.99
5 uses	F5@.120	SFCA	2.54	5.85	8.39

Shores for beams and girders Using 4" x 4" wooden posts. These figures assume an average shore height of 12'0" with a 2'0" long horizontal 4" x 4" head and 2" x 6" diagonal brace (30 BF of lumber per shore) and include nails, adjustable post clamps and accessories. For scheduling purposes estimate that a crew of 5 can lay out, fabricate and install 30 to 35 adjustable wood shores in an 8-hour day when shores have an average height of 12'0". Quantity and spacing of shores is dictated by the size of the beams and girders. Generally, allow one shore for each 6 LF of beam or girder. Costs for heavy-duty shoring are listed under General Requirements, Heavy-Duty Shoring.

1 use	F5@1.50	Ea	47.00	73.20	120.20
3 uses	F5@1.00	Ea	25.00	48.80	73.80
5 uses	F5@.748	Ea	20.60	36.50	57.10

Elevated slab forms These are costs for forms per square foot of finished slab area and include shoring and stripping at heights to 12'. Bays are assumed to be 20' x 20' bays.

Waffle slab-joint pans, monolithic Using rented forms (30-day rental period minimum). For scheduling purposes, estimate that a crew of 5 can lay out, fabricate and install 500 to 600 SF of waffle slab-joint pan forms and shoring in an 8-hour day. Two uses of the forms in a 30-day period is usually the maximum.

Metal pans, 10,000 to 20,000 SF

1 use	F5@.100	SF	7.09	4.88	11.97
2 uses	F5@.066	SF	3.97	3.22	7.19

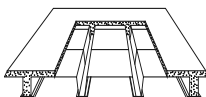

Fiberglass pans, 10,000 to 20,000 SF

1 use	F5@.077	SF	8.29	3.76	12.05
2 uses	F5@.061	SF	4.73	2.98	7.71

Flat slab with beams, monolithic Including nails, braces, stiffeners and oil 1.2 SF of plyform and 3.2 BF of lumber per SFCA for one-way beam systems. Two-way beam systems require approximately 40% more forming materials than one-way beam systems. For scheduling purposes, estimate that a crew of 5 can lay out, fabricate and erect 350 to 400 SF of one-way beam systems and 250 to 300 SF of two-way beam systems in an 8-hour day, including shoring.

One-way beam 1 use	F5@.110	SFCA	7.10	5.37	12.47
One-way beam 2 uses	F5@.080	SFCA	5.31	3.90	9.21
Two-way beam 1 use	F5@.152	SFCA	9.85	7.41	17.26
Two-way beam 2 uses	F5@.100	SFCA	5.63	4.88	10.51

Structural flat-slab Using nails, braces, stiffeners and oil costing \$.25, 1.2 SF of plyform and 2.25 BF of lumber per SFCA. For scheduling purposes, estimate that a crew of 5 can lay out, fabricate and erect 500 to 600 SFCA of structural flat-slab forms in an 8-hour day, including shoring.

Edge forms	F5@.072	LF	3.06	3.51	6.57
Slab forms 1 use	F5@.069	SFCA	5.92	3.37	9.29
Slab forms 3 uses	F5@.048	SFCA	3.08	2.34	5.42
Slab forms 5 uses	F5@.043	SFCA	2.52	2.10	4.62

Additional forming costs for elevated slabs, if required Based on single use of plyform and lumber. For scheduling purposes estimate that a 5 man crew can install 500 SFCA per 8-hour day.

Control joints	F5@.031	LF	3.27	1.51	4.78
Curbs and pads	F5@.083	SFCA	5.92	4.05	9.97
Depressions	F5@.083	SFCA	1.78	4.05	5.83
Keyed joints	F5@.031	LF	1.38	1.51	2.89

03 Concrete

Miscellaneous formwork Based on single use of plyform and lumber. For scheduling purposes, estimate that a crew of 5 can lay out, fabricate and erect 225 to 250 SFCA of these types of forms in an 8-hour day.

	Craft@Hrs	Unit	Material	Labor	Total
Flat soffits & landings	F5@.166	SFCA	9.18	8.10	17.28
Sloping soffits	F5@.166	SFCA	9.47	8.10	17.57
Stair risers (steps)	F5@.120	SFCA	3.55	5.85	9.40

Reinforcing Steel Bars 20' lengths, material costs only. Add the cost of delivery, shop fabrication, cutting, bending, setting, lap and tying bars.

ASTM-615 grade 60

3/8" x 20'	—	Ea	7.26	—	7.26
1/2" x 20'	—	Ea	11.40	—	11.40
5/8" x 20'	—	Ea	17.90	—	17.90
3/4" x 20'	—	Ea	20.90	—	20.90
1" x 20'	—	Ea	49.40	—	49.40

ASTM-775 epoxy-coated

1/2" x 20'	—	Ea	24.70	—	24.70
5/8" x 20'	—	Ea	35.50	—	35.50
3/4" x 20'	—	Ea	50.90	—	50.90

Reinforcing for Cast-in-Place Concrete Steel reinforcing bars (rebar), ASTM A615 Grade 60. Material costs are for deformed steel reinforcing rebar, including 10% lap allowance, cutting and bending. These costs also include detailed shop drawings and delivery to jobsite with identity tags per shop drawings. Add for epoxy or galvanized coating of rebar, chairs, splicing, spiral caissons and round column reinforcing, if required, from the sections following the data below. Costs per pound (Lb) and per linear foot (LF) including tie wire and tying.

Reinforcing steel placed and tied in footings, foundations and grade beams

1/4" diameter, #2 rebar	RB@.015	Lb	1.51	.99	2.50
1/4" diameter, #2 rebar (.17 lb per LF)	RB@.003	LF	.26	.20	.46
3/8" diameter, #3 rebar	RB@.011	Lb	1.03	.72	1.75
3/8" diameter, #3 rebar (.38 lb per LF)	RB@.004	LF	.39	.26	.65
1/2" diameter, #4 rebar	RB@.010	Lb	.88	.66	1.54
1/2" diameter, #4 rebar (.67 lb per LF)	RB@.007	LF	.59	.46	1.05
5/8" diameter, #5 rebar	RB@.009	Lb	.94	.59	1.53
5/8" diameter, #5 rebar (1.04 lb per LF)	RB@.009	LF	.98	.59	1.57
3/4" diameter, #6 rebar	RB@.008	Lb	.79	.53	1.32
3/4" diameter, #6 rebar (1.50 lb per LF)	RB@.012	LF	1.19	.79	1.98
7/8" diameter, #7 rebar	RB@.008	Lb	.97	.53	1.50
7/8" diameter, #7 rebar (2.04 lb per LF)	RB@.016	LF	1.97	1.05	3.02
1" diameter, #8 rebar	RB@.008	Lb	.82	.53	1.35
1" diameter, #8 rebar (2.67 lb per LF)	RB@.021	LF	2.19	1.38	3.57
1-1/8" diameter, #9 rebar	RB@.008	Lb	1.03	.53	1.56
1-1/8" diameter, #9 rebar (3.40 lb per LF)	RB@.027	LF	3.51	1.78	5.29
1-1/4" diameter, #10 rebar	RB@.007	Lb	1.03	.46	1.49
1-1/4" diameter, #10 rebar (4.30 lb per LF)	RB@.030	LF	4.44	1.97	6.41
1-3/8" diameter, #11 rebar	RB@.007	Lb	1.03	.46	1.49
1-3/8" diameter, #11 rebar (5.31 lb per LF)	RB@.037	LF	5.48	2.43	7.91

Reinforcing steel placed and tied in structural slabs

1/4" diameter, #2 rebar	RB@.014	Lb	1.51	.92	2.43
1/4" diameter, #2 rebar (.17 lb per LF)	RB@.002	LF	.26	.13	.39
3/8" diameter, #3 rebar	RB@.010	Lb	1.03	.66	1.69
3/8" diameter, #3 rebar (.38 lb per LF)	RB@.004	LF	.39	.26	.65
1/2" diameter, #4 rebar	RB@.009	Lb	.89	.59	1.48
1/2" diameter, #4 rebar (.67 lb per LF)	RB@.006	LF	.59	.39	.98
5/8" diameter, #5 rebar	RB@.008	Lb	.94	.53	1.47

03 Concrete

	Craft@Hrs	Unit	Material	Labor	Total
5/8" diameter, #5 rebar (1.04 lb per LF)	RB@.008	LF	.98	.53	1.51
3/4" diameter, #6 rebar	RB@.007	Lb	.79	.46	1.25
3/4" diameter, #6 rebar (1.50 lb per LF)	RB@.011	LF	1.19	.72	1.91
7/8" diameter, #7 rebar	RB@.007	Lb	.97	.46	1.43
7/8" diameter, #7 rebar (2.04 lb per LF)	RB@.014	LF	1.97	.92	2.89
1" diameter, #8 rebar	RB@.007	Lb	.82	.46	1.28
1" diameter, #8 rebar (2.67 lb per LF)	RB@.019	LF	2.19	1.25	3.44
1-1/8" diameter, #9 rebar	RB@.007	Lb	1.03	.46	1.49
1-1/8" diameter, #9 rebar (3.40 lb per LF)	RB@.024	LF	3.51	1.58	5.09
1-1/4" diameter, #10 rebar	RB@.006	Lb	1.03	.39	1.42
1-1/4" diameter, #10 rebar (4.30 lb per LF)	RB@.026	LF	4.44	1.71	6.15
1-3/8" diameter, #11 rebar	RB@.006	Lb	1.03	.39	1.42
1-3/8" diameter, #11 rebar (5.31 lb per LF)	RB@.032	LF	5.48	2.10	7.58
Reinforcing steel placed and tied in columns, stairs and walls					
1/4" diameter, #2 rebar	RB@.017	Lb	1.51	1.12	2.63
1/4" diameter, #2 rebar (.17 lb per LF)	RB@.003	LF	.26	.20	.46
3/8" diameter, #3 rebar	RB@.012	Lb	1.03	.79	1.82
3/8" diameter, #3 rebar (.38 lb per LF)	RB@.005	LF	.39	.33	.72
1/2" diameter, #4 rebar	RB@.011	Lb	.88	.72	1.60
1/2" diameter, #4 rebar (.67 lb per LF)	RB@.007	LF	.59	.46	1.05
5/8" diameter, #5 rebar	RB@.010	Lb	.94	.66	1.60
5/8" diameter, #5 rebar (1.04 lb per LF)	RB@.010	LF	.98	.66	1.64
3/4" diameter, #6 rebar	RB@.009	Lb	.79	.59	1.38
3/4" diameter, #6 rebar (1.50 lb per LF)	RB@.014	LF	1.19	.92	2.11
7/8" diameter, #7 rebar	RB@.009	Lb	.97	.59	1.56
7/8" diameter, #7 rebar (2.04 lb per LF)	RB@.018	LF	1.97	1.18	3.15
1" diameter, #8 rebar	RB@.009	Lb	.82	.59	1.41
1" diameter, #8 rebar (2.67 lb per LF)	RB@.024	LF	2.19	1.58	3.77
1-1/8" diameter, #9 rebar	RB@.009	Lb	1.03	.59	1.62
1-1/8" diameter, #9 rebar (3.40 lb per LF)	RB@.031	LF	3.51	2.04	5.55
1-1/4" diameter, #10 rebar	RB@.008	Lb	1.03	.53	1.56
1-1/4" diameter, #10 rebar (4.30 lb per LF)	RB@.034	LF	4.44	2.24	6.68
1-3/8" diameter, #11 rebar	RB@.008	Lb	1.03	.53	1.56
1-3/8" diameter, #11 rebar (5.31 lb per LF)	RB@.037	LF	5.48	2.43	7.91
Epoxy coating, add to uncoated bars, per pound					
Any size rebar, add	—	Lb	.41	—	.41
Galvanized coating, add to uncoated bars, per pound					
Any #2 rebar, #3 rebar or #4 rebar, add	—	Lb	.53	—	.53
Any #5 rebar or #6 rebar, add	—	Lb	.48	—	.48
Any #7 rebar or #8 rebar, add	—	Lb	.50	—	.50
Any #9 rebar, #10 rebar or #11 rebar, add	—	Lb	.47	—	.47
Pre-bent rebar, 90 degree except as noted					
3/8" diameter, #3 rebar, 24" x 24"	RB@.014	Ea	2.51	.92	3.43
1/2" diameter, #4 rebar, 10" x 3'	RB@.021	Ea	5.46	1.38	6.84
1/2" diameter, #4 rebar, 2' x 3'	RB@.021	Ea	7.01	1.38	8.39
5/8" diameter, #5 rebar, 24" x 24"	RB@.014	Ea	7.89	.92	8.81
5/8" diameter, #5 rebar, 1' x 4'	RB@.035	Ea	10.00	2.30	12.30
5/8" diameter, #5 rebar, 3' x 3'	RB@.043	Ea	10.80	2.83	13.63
5/8" diameter, #5 rebar, 30" x 9" J-bar	RB@.028	Ea	4.26	1.84	6.10
3/4" diameter, #6 rebar, 24" x 24"	RB@.043	Ea	11.00	2.83	13.83
Rebar stirrups					
3/8" #3 bar, 6" x 12"	RB@.014	Ea	2.65	.92	3.57
3/8" #3 bar, 6" x 14"	RB@.014	Ea	3.04	.92	3.96
3/8" #3 bar, 6" x 18"	RB@.014	Ea	3.45	.92	4.37
3/8" #3 bar, 6" x 24"	RB@.014	Ea	3.45	.92	4.37
5/8" #8 bar, 6" x 48"	RB@.014	Ea	8.12	.92	9.04

03 Concrete

	Craft@Hrs	Unit	Material	Labor	Total
Rebar rings					
Rectangular, 6" x 3-1/2"	RB@.014	Ea	2.06	.92	2.98
Rectangular, 9" x 5"	RB@.014	Ea	2.65	.92	3.57
Rectangular, 11" x 5"	RB@.014	Ea	2.46	.92	3.38
Rectangular, 12" x 3-1/2"	RB@.014	Ea	2.66	.92	3.58
Rectangular, 14" x 4"	RB@.014	Ea	2.66	.92	3.58
Rectangular, 14" x 5"	RB@.014	Ea	2.51	.92	3.43
Round, 6" diameter	RB@.014	Ea	2.30	.92	3.22
Round, 8" diameter	RB@.014	Ea	2.14	.92	3.06
Round, 10" diameter	RB@.014	Ea	2.67	.92	3.59
Square, 8"	RB@.014	Ea	2.59	.92	3.51
Reinforcing steel chairs. Labor for placing rebar shown above includes time for setting chairs.					
Chairs, individual type, cost each					
3" high					
Steel	—	Ea	.89	—	.89
Plastic	—	Ea	.32	—	.32
Galvanized steel	—	Ea	1.61	—	1.61
5" high					
Steel	—	Ea	1.35	—	1.35
Plastic	—	Ea	.82	—	.82
Galvanized steel	—	Ea	2.10	—	2.10
8" high					
Steel	—	Ea	2.86	—	2.86
Plastic	—	Ea	1.69	—	1.69
Galvanized steel	—	Ea	4.53	—	4.53
12" high					
Steel	—	Ea	5.72	—	5.72
Plastic	—	Ea	2.72	—	2.72
Galvanized steel	—	Ea	6.99	—	6.99
Chairs, continuous type, with legs 8" OC, cost per linear foot					
3" high					
Steel	—	LF	1.23	—	1.23
Plastic	—	LF	.69	—	.69
Galvanized steel	—	LF	1.87	—	1.87
6" high					
Steel	—	LF	1.69	—	1.69
Plastic	—	LF	.95	—	.95
Galvanized steel	—	LF	2.65	—	2.65
8" high					
Steel	—	LF	2.58	—	2.58
Plastic	—	LF	1.76	—	1.76
Galvanized steel	—	LF	3.72	—	3.72
12" high					
Steel	—	LF	5.60	—	5.60
Plastic	—	LF	2.79	—	2.79
Galvanized steel	—	LF	6.72	—	6.72
Reinforcing bar weld splicing. Cost per splice					
#8 bars, #9 bars or #10 bars	RB@.527	Ea	4.35	34.70	39.05
Reinforcing bar clip splicing, sleeve and wedge, with hand-held hydraulic ram. Cost per splice					
Number 4 bars, 1/2"	RB@.212	Ea	9.59	13.90	23.49
Number 5 bars, 5/8"	RB@.236	Ea	22.50	15.50	38.00
Number 6 bars, 3/4"	RB@.258	Ea	41.90	17.00	58.90

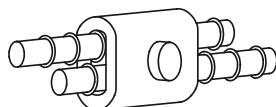

03 Concrete

	Craft@Hrs	Unit	Material	Labor	Total
Waterstop, 3/8"					
Rubber, 6"	B2@.059	LF	1.45	2.12	3.57
Rubber, 9"	B2@.059	LF	3.14	2.12	5.26
Spiral caisson and round column reinforcing, 3/8" diameter hot rolled steel spirals with main vertical bars as shown.					
Costs include typical engineering and shop drawings. Shop fabricated spirals delivered, tagged, ready to install.					
Cost per vertical linear foot (VLF)					
16" diameter with 6 #6 bars, 16.8 lbs per VLF	RB@.041	VLF	52.30	2.70	55.00
24" diameter with 6 #6 bars, 28.5 lbs per VLF	RB@.085	VLF	89.30	5.59	94.89
36" diameter with 8 #10 bars, 51.2 lbs per VLF	RB@.216	VLF	163.00	14.20	177.20
Welded wire mesh steel, electric weld, including 15% waste and overlap					
2" x 2" W.9 x W.9 (#12 x #12), slabs	RB@.004	SF	1.40	.26	1.66
2" x 2" W.9 x W.9 (#12 x #12), beams and columns	RB@.020	SF	1.40	1.32	2.72
4" x 4" W1.4 x W1.4 (#10 x #10), slabs	RB@.003	SF	.67	.20	.87
4" x 4" W2.0 x W2.0 (#8 x #8), slabs	RB@.004	SF	.78	.26	1.04
4" x 4" W2.9 x W2.9 (#6 x #6), slabs	RB@.005	SF	.87	.33	1.20
4" x 4" W4.0 x W4.0 (#4 x #4), slabs	RB@.006	SF	1.16	.39	1.55
6" x 6" W1.4 x W1.4 (#10 x #10), slabs	RB@.003	SF	.29	.20	.49
6" x 6" W2.0 x W2.0 (#8 x #8), slabs	RB@.004	SF	.52	.26	.78
6" x 6" W2.9 x W2.9 (#6 x #6), slabs	RB@.004	SF	.60	.26	.86
6" x 6" W4.0 x W4.0 (#4 x #4), slabs	RB@.005	SF	.82	.33	1.15
Add for lengthwise cut, LF of cut	RB@.002	LF	—	.13	.13
Welded wire mesh, galvanized steel, electric weld, including 15% waste and overlap					
2" x 2" W.9 x W.9 (#12 x #12), slabs	RB@.004	SF	2.83	.26	3.09
2" x 2" W.9 x W.9 (#12 x #12), beams and columns	RB@.020	SF	2.83	1.32	4.15
4" x 4" W1.4 x W1.4 (#10 x #10), slabs	RB@.003	SF	1.32	.20	1.52
4" x 4" W2.0 x W2.0 (#8 x #8), slabs	RB@.004	SF	1.59	.26	1.85
4" x 4" W2.9 x W2.9 (#6 x #6), slabs	RB@.005	SF	1.75	.33	2.08
4" x 4" W4.0 x W4.0 (#4 x #4), slabs	RB@.006	SF	2.29	.39	2.68
6" x 6" W1.4 x W1.4 (#10 x #10), slabs	RB@.003	SF	.74	.20	.94
6" x 6" W2.0 x W2.0 (#8 x #8), slabs	RB@.004	SF	.91	.26	1.17
6" x 6" W2.9 x W2.9 (#6 x #6), slabs	RB@.004	SF	1.16	.26	1.42
6" x 6" W4.0 x W4.0 (#4 x #4), slabs	RB@.005	SF	1.67	.33	2.00
Add for lengthwise cut, LF of cut	RB@.002	LF	—	.13	.13
Welded wire mesh, epoxy-coated steel, electric weld, including 15% waste and overlap					
2" x 2" W.9 x W.9 (#12 x #12), slabs	RB@.004	SF	5.82	.26	6.08
2" x 2" W.9 x W.9 (#12 x #12), beams and columns	RB@.020	SF	5.82	1.32	7.14
4" x 4" W1.4 x W1.4 (#10 x #10), slabs	RB@.003	SF	5.20	.20	5.40
4" x 4" W2.0 x W2.0 (#8 x #8), slabs	RB@.004	SF	5.16	.26	5.42
4" x 4" W2.9 x W2.9 (#6 x #6), slabs	RB@.005	SF	5.25	.33	5.58
4" x 4" W4.0 x W4.0 (#4 x #4), slabs	RB@.006	SF	5.52	.39	5.91
6" x 6" W1.4 x W1.4 (#10 x #10), slabs	RB@.003	SF	4.74	.20	4.94
6" x 6" W2.0 x W2.0 (#8 x #8), slabs	RB@.004	SF	4.84	.26	5.10
6" x 6" W2.9 x W2.9 (#6 x #6), slabs	RB@.004	SF	4.92	.26	5.18
6" x 6" W4.0 x W4.0 (#4 x #4), slabs	RB@.005	SF	5.20	.33	5.53
Add for lengthwise cut, LF of cut	RB@.002	LF	—	.13	.13
Reinforcing mesh mini-mats, electric weld, including 15% waste and overlap					
6" x 6" W1.4 x W1.4 (#10 x #10), 4' x 8'	RB@.004	SF	.39	.26	.65

03 Concrete

	Craft@Hrs	Unit	Material	Labor	Total
Ready-Mix Concrete Ready-mix delivered by truck. Typical prices for most cities. Includes delivery up to 20 miles for 10 CY or more, 3" to 4" slump. Material cost only, no placing or pumping included. All concrete material costs in this manual are based on these figures.					
5.0 sack mix, 2,000 PSI	—	CY	128.00	—	128.00
6.0 sack mix, 3,000 PSI	—	CY	133.00	—	133.00
6.6 sack mix, 3,500 PSI	—	CY	136.00	—	136.00
7.1 sack mix, 4,000 PSI	—	CY	138.00	—	138.00
8.5 sack mix, 5,000 PSI	—	CY	158.00	—	158.00
Extra costs for ready-mix concrete					
Add for less than 10 CY per load	—	CY	55.80	—	55.80
Add for delivery over 20 miles	—	Mile	10.20	—	10.20
Add for standby charge in excess of 5 minutes per CY delivered, per minute of extra time	—	Ea	3.18	—	3.18
Add for super-plasticized mix, 7"-8" slump	—	%	8.0	—	—
Add for lightweight aggregate, typical	—	CY	58.60	—	58.60
Add for pump mix (pea-gravel aggregate)	—	CY	12.70	—	12.70
Add for granite aggregate, typical	—	CY	9.20	—	9.20
Add for white cement (architectural)	—	CY	75.80	—	75.80
Add for 1% calcium chloride	—	CY	2.13	—	2.13
Add for chemical compensated shrinkage	—	CY	27.90	—	27.90
Add for high early strength concrete					
5 sack mix	—	CY	16.60	—	16.60
6 sack mix	—	CY	22.00	—	22.00
Add for colored concrete, typical prices. The ready-mix supplier charges for cleanup of the ready-mix truck used for delivery of colored concrete. The usual practice is to provide one truck per day for delivery of all colored concrete for a particular job. Add the cost below to the cost per cubic yard for the design mix required. Also, add the cost for truck cleanup. Cost will be based on the quantity of pigment required. Pastels require one to two pounds of pigment per sack of cement. Greater color density may require up to five pounds of pigment per cubic yard. Cost per cubic yard based on a 5-sack mix and one pound of color per sack.					
Colored concrete, truck cleanup, per day	—	LS	101.00	—	101.00
Most colors (tan, brown, gray, beige)	—	CY	32.80	—	32.80
Green (requires white cement)	—	CY	59.50	—	59.50
Blue (requires white cement)	—	CY	180.00	—	180.00
White concrete pigment	—	CY	45.90	—	45.90
Concrete Pumping, Subcontract Small jobs, including trailer mounted pump and operator at 15 CY per hour. Based on 6 sack concrete mix designed for pumping. No concrete included. \$125.00 minimum charge.					
3/8" aggregate mix (pea gravel), using hose to 200'					
Cost per cubic yard (pumping only)	—	CY	—	—	15.80
Add for hose over 200', per LF	—	LF	—	—	2.25
3/4" aggregate mix, using hose to 200'					
Cost per cubic yard (pumping only)	—	CY	—	—	16.40
Add for hose over 200', per LF	—	LF	—	—	1.98
Concrete Pumping with a Boom Truck, Subcontract Includes truck rent, operator, local travel but no concrete. Add costs equal to 1 hour for equipment setup and 1 hour for cleanup. Use 4 hours as the minimum cost for 23-, 28- and 32-meter boom trucks and 5 hours as the minimum cost for 36- through 52-meter boom trucks. Estimate the actual pour rate at 70% of the rated capacity on thicker slabs and 50% of the capacity on most other work. Costs include operator and oiler where necessary. Costs shown include subcontractor's markup.					
23-meter boom (75'), 70 CY per hour rating	—	Hr	—	—	142.00
Add per CY pumped with 23-meter boom	—	CY	—	—	3.23
28-meter boom (92'), 70 CY per hour rating	—	Hr	—	—	163.00
Add per CY pumped with 28-meter boom	—	CY	—	—	3.25
32-meter boom (105'), 90 CY per hour rating	—	Hr	—	—	191.00
Add per CY pumped with 32-meter boom	—	CY	—	—	3.31

03 Concrete

	Craft@Hrs	Unit	Material	Labor	Total	
36-meter boom (120'), 90 CY per hour rating	—	Hr	—	—	234.00	
Add per CY pumped with 36-meter boom	—	CY	—	—	3.29	
42-meter boom (138'), 100 CY per hour rating	—	Hr	—	—	309.00	
Add per CY pumped with 42-meter boom	—	CY	—	—	3.92	
52-meter boom (170'), 100 CY per hour rating	—	Hr	—	—	362.00	
Add per CY pumped with 52-meter boom	—	CY	—	—	4.43	
	Craft@Hrs	Unit	Material	Labor	Equipment	Total
Ready-Mix Concrete and Placing No forms, finishing or reinforcing included. Material cost is based on 3,000 PSI concrete. Use \$900 minimum charge for boom truck and \$125 minimum for trailer-mounted pump.						
Columns						
By crane (60-ton crawler crane)	H3@.873	CY	133.00	41.20	23.70	197.90
By pump (28-meter boom truck and operator)	M2@.062	CY	145.00	2.83	6.24	154.07
Slabs-on-grade						
Direct from chute	CL@.430	CY	133.00	17.90	—	150.90
By crane (60-ton crawler crane)	H3@.594	CY	133.00	28.00	16.20	177.20
By pump (trailer-mounted, 20 CY/ hour)	M2@.188	CY	145.00	8.58	5.15	158.73
With buggy	CL@.543	CY	145.00	22.60	7.79	175.39
Elevated slabs						
By crane (60-ton crawler crane)	H3@.868	CY	133.00	41.00	23.60	197.60
By pump (28-meter boom truck and operator)	M2@.054	CY	145.00	2.46	5.69	153.15
Footings, pile caps, foundations						
Direct from chute	CL@.564	CY	133.00	23.50	—	23.50
By pump (trailer-mounted, 30 CY/ hour)	M2@.125	CY	145.00	5.70	2.18	152.88
With buggy	CL@.701	CY	145.00	29.20	10.10	184.30
Beams and girders						
By pump (28-meter boom truck and operator)	M2@.062	CY	145.00	2.83	6.24	154.07
By crane (60-ton crawler crane)	H3@.807	CY	145.00	38.10	22.00	205.10
Stairs						
Direct from chute	CL@.814	CY	133.00	33.90	—	155.20
By crane (60-ton crawler crane)	H3@1.05	CY	145.00	49.60	28.60	223.20
By pump (28-meter boom truck and operator)	M2@.108	CY	145.00	4.93	9.38	159.31
With buggy	CL@.948	CY	145.00	39.50	13.60	198.10
Walls and grade beams to 4' high						
Direct from chute	CL@.479	CY	133.00	20.00	—	20.00
By pump (trailer-mounted, 20 CY/ hour)	M2@.188	CY	145.00	8.58	1.72	155.30
With buggy	CL@.582	CY	145.00	24.20	8.35	177.55
Walls over 4' to 8' high						
By crane (60-ton crawler crane)	H3@.821	CY	133.00	38.80	22.30	194.10
By pump (28-meter boom truck and operator)	M2@.062	CY	145.00	2.83	4.24	152.07
Walls over 8' to 16' high						
By crane (60-ton crawler crane)	H3@.895	CY	133.00	42.20	24.30	199.50
By pump (28-meter boom truck and operator)	M2@.078	CY	145.00	3.56	7.33	155.89
Walls over 16' high						
By crane (60-ton crawler crane)	H3@.986	CY	133.00	46.50	26.80	206.30
By pump (28-meter boom truck and operator)	M2@.097	CY	145.00	4.43	8.63	158.06

03 Concrete

	Craft@Hrs	Unit	Material	Labor	Equipment	Total
Concrete Slab-on-Grade Assemblies Typical costs including fine grading, edge forms, 3,000 PSI concrete, wire mesh, finishing and curing.						
4" thick 4' x 6' equipment pad						
Hand trimming and shaping, 24 SF	CL@.512	LS	—	21.30	—	21.30
Lay out, set and strip edge forms, 20 LF, 5 uses	C8@1.30	LS	20.00	61.90	—	81.90
Place .006" polyethylene vapor barrier 24 SF	CL@.048	LS	2.29	2.00	—	4.29
Place W2.9 x W2.9 x 6" x 6" mesh, 24 SF	RB@.097	LS	14.30	6.38	—	20.68
Place ready-mix concrete, from chute .3 CY	CL@.127	LS	39.90	5.29	—	45.19
Finish concrete, broom finish	CM@.591	LS	—	30.60	—	30.60
Cure concrete, curing paper	CL@.124	LS	5.17	5.17	—	10.34
Total job cost for 4" thick 24 SF pad	—@2.80	LS	81.66	132.64	—	214.30
Cost per SF for 4" thick 24 SF pad	—@.116	SF	3.40	5.53	—	8.93
Cost per CY of 4" thick concrete, .3 CY job	—@9.33	CY	272.00	442.00	—	714.00
8" thick 10' x 10' equipment pad						
Hand trimming and shaping, 100 SF	CL@2.79	LS	—	116.00	—	116.00
Lay out, set and strip edge forms, 40 LF, 5 uses	C8@3.28	LS	54.90	156.00	—	210.90
Place .006" polyethylene vapor barrier 100 SF	CL@.200	LS	9.54	8.33	—	17.87
Place W2.9 x W2.9 x 6" x 6" mesh, 100 SF	RB@.400	LS	59.50	26.30	—	85.80
Place ready-mix concrete, from chute 2.5 CY	CL@1.08	LS	332.00	45.00	—	377.00
Finish concrete, broom finish	CM@2.11	LS	—	109.00	—	109.00
Cure concrete, curing paper	CL@.515	LS	21.50	21.50	—	43.00
Total job cost for 8" thick 100 SF pad	—@10.4	LS	477.44	482.13	—	959.57
Cost per SF for 8" thick 100 SF job	—@.104	SF	4.77	4.82	—	9.59
Cost per CY of 8" thick concrete, 2.5 CY job	—@4.15	CY	191.00	193.00	—	284.00
Note: Ready-mix concrete used in both examples assumes a minimum of 10 cubic yards will be delivered (per load) with the excess used elsewhere on the same job.						
Add for each CY less than 10 delivered	—	CY	55.80	—	—	55.80
Floor Slab Assemblies Typical reinforced concrete slab-on-grade including excavation, gravel fill, forms, vapor barrier, wire mesh, 3,000 PSI concrete, finishing and curing.						
3,000 PSI concrete	—	CY	257.00	—	—	257.00
4" thick slab	—@.025	SF	3.19	1.29	.15	4.63
5" thick slab	—@.026	SF	3.60	1.34	.15	5.09
6" thick slab	—@.027	SF	4.01	1.39	.16	5.56
Detailed cost breakdown slab as described above:						
4" thick 100' x 75' slab						
Grade sandy loam site using a D-4 tractor, 140 CY, balanced job, (no import or export)	S1@2.66	LS	—	132.00	84.30	216.30
Buy and spread 6" crushed rock base using a D-4 tractor, 140 CY	S1@15.8	LS	4,260.00	786.00	501.00	5,547.00
Lay out, set and strip edge forms, 350 LF, 5 uses	C8@19.6	LS	349.00	933.00	—	1,282.00

03 Concrete

	Craft@Hrs	Unit	Material	Labor	Equipment	Total
Place .006" polyethylene vapor barrier 7,500 SF	CL@8.84	LS	716.00	368.00	—	1,084.00
Place W2.9 x W2.9 x 6" x 6" mesh, 7,500 SF	RB@30.0	LS	4,470.00	1,970.00	—	6,440.00
Place and remove 2" x 4" keyway, 200 LF, 1 use	C8@8.80	LS	173.00	419.00	—	592.00
Place 4" concrete, 93 CY, from chute	CL@39.9	LS	12,400.00	1,660.00	—	14,060.00
Float finish 7,500 SF	CM@52.4	LS	—	2,720.00	503.00	3,223.00
Cure with slab curing paper	CM@5.58	LS	1,620.00	289.00	—	1,909.00
Total job cost 4" thick						
100' x 75' floor slab	—@184	LS	23,988.00	9,277.00	1,088.30	34,353.30
Cost per SF for 4" thick 7,500 SF job	—@.025	SF	3.20	1.24	.15	4.59
Cost per CY for 4" thick 93 CY job	—@1.98	CY	258.00	99.80	11.70	369.50
Cost per each additional 1" of concrete	—@.001	SF	.41	.06	—	.47

Cast-in-Place Concrete, Subcontract Typical costs including forms, concrete, reinforcing, finishing and curing. These costs include the subcontractor's overhead and profit but no excavation, shoring or backfill. Use these figures only for preliminary estimates and on jobs that require a minimum of 1,000 CY of concrete.

Foundations

Institutional or office buildings	—	CY	—	—	—	728.00
Heavy engineered structures	—	CY	—	—	—	790.00

Structural concrete walls

Single-story, 8" wall	—	CY	—	—	—	993.00
Single-story, 10" wall	—	CY	—	—	—	1,070.00
Multi-story, 8" wall	—	CY	—	—	—	1,230.00
Multi-story, 10"	—	CY	—	—	—	1,270.00
Slip-formed 8" wall	—	CY	—	—	—	1,090.00

Structural slabs, including shoring,

6", 1 way beams, 100 pounds reinforcing	—	CY	—	—	—	1,130.00
6", 2 way beams, 225 pounds reinforcing	—	CY	—	—	—	1,050.00
8", flat, with double mat reinforcing over steel frame by others, 100 pounds reinforcing	—	CY	—	—	—	950.00
12" flat, 250 pounds reinforcing bars per CY	—	CY	—	—	—	858.00
7", post-tensioned, to 1 pound tempered bars	—	CY	—	—	—	1,060.00
6" to 8" including beam jacketing	—	CY	—	—	—	1,040.00
6" to 8" on permanent metal form	—	CY	—	—	—	946.00
8" concurrent with slipform construction	—	CY	—	—	—	999.00
Lift slab construction 6" to 8"	—	SF	—	—	—	22.60

Pan and joist slabs 3" thick, 30" pan, including shoring

6" x 16" joist	—	CY	—	—	—	1,110.00
6" x 12" joist	—	CY	—	—	—	980.00
6" x 10" joist	—	CY	—	—	—	950.00

Pan and joist slabs 4-1/2" thick, 20" pan, including shoring

6" x 20" joist	—	CY	—	—	—	945.00
6" x 16" joist	—	CY	—	—	—	925.00
6" x 12" joist	—	CY	—	—	—	915.00

03 Concrete

	Craft@Hrs	Unit	Material	Labor	Equipment	Total
Parapet and fascia, 6" thick	—	CY	—	—	—	1,410.00
Loading docks, based on 8" walls and 8" slab	—	CY	—	—	—	664.00
Beams and girders, not slab integrated						
12" x 24", typical	—	CY	—	—	—	1,870.00
18" x 24", typical	—	CY	—	—	—	1,430.00
Columns, average reinforcing						
Square, wood formed, with chamfer						
12" column	—	CY	—	—	—	2,280.00
16" column	—	CY	—	—	—	2,110.00
18" column	—	CY	—	—	—	1,930.00
20" column	—	CY	—	—	—	1,790.00
24" column	—	CY	—	—	—	1,580.00
Round, fiber tube formed, 12" to 18"	—	CY	—	—	—	1,510.00

Cast-in-Place Concrete Steps-on-Grade Assemblies Typical in-place costs, including layout, fabrication and placing forms, setting and tying steel reinforcing, installation of steel nosing, placing 2,000 PSI concrete directly from the chute of a ready-mix truck, finishing, stripping forms and curing. Costs assume excavation, back filling and compaction have been completed by others. Crew is a carpenter, laborer and finisher. Formwork is based on using standard & better lumber and concrete and includes a 5% waste allowance. For scheduling purposes, estimate that a crew of 3 can set forms and place steel for and pour 4 to 5 CY of concrete cast-in-place steps in an 8-hour day. Costs shown are for concrete steps with a 6" riser height and 12" tread depth supported by a 6" thick monolithic slab. The "tricks of the trade" that follow explains how to use these unit prices to estimate stairways of various widths and heights. Note: Total cost per CY has been rounded. For more detailed coverage of formed concrete stairs, see the *National Concrete & Masonry Estimator*, <https://craftsman-book.com/national-estimator-cloud>.

	Craft@Hrs	Unit	Material	Labor	Total
Fabricate and erect forms, 2 uses of forms, includes stakes, braces, form oil and nails at \$.13 per LF of forms					
Side forms, 1.7 BF per LF of tread	P9@.080	LF	1.08	3.92	5.00
Riser forms, 1.5 BF per LF of tread	P9@.040	LF	.97	1.96	2.93
Rebar, #3, Grade 60, 1 pound per LF of tread	P9@.009	LF	1.03	.44	1.47
Embedded steel step nosing, 2-1/2" x 2-1/2" x 1/4" black mild steel					
Angle iron, 4.5 pounds per LF of tread.	P9@.004	LF	5.65	.20	5.85
Concrete, .03 CY per LF of tread	P9@.030	LF	3.99	1.47	5.46
Total cost per LF of risers	P9@.163	LF	12.72	7.99	20.71
Total cost per CY of concrete	P9@5.43	CY	424.00	266.00	690.00

Tricks of the trade:

To quickly estimate the cost of cast-in-place concrete steps-on-grade, do this:

Multiply the width of the steps (in feet) times their height in feet and multiply the result times 2.

This will give the total linear feet (LF) of risers in the steps. Multiply the total LF by the costs per LF.

Sample estimates for cast-in-place concrete steps-on-grade using the procedure and costs from above:

2'6" wide by 3' high (6 steps) would be: $2.5' \times 3' \times 2 = 15 \text{ LF} \times \$20.71 = \$310.65$

3' wide by 3' high (6 steps) would be: $3' \times 3' \times 2 = 18 \text{ LF} \times \$20.71 = \$372.78$

4' wide by 4' high (8 steps) would be: $4' \times 4' \times 2 = 32 \text{ LF} \times \$20.71 = \$662.72$

7' wide by 4'6" high (9 steps) would be: $7' \times 4.5' \times 2 = 63 \text{ LF} \times \$20.71 = \$1,304.73$

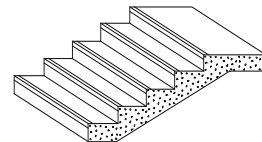

Tip for using these estimates with *The National Estimator* computer estimating program:

Calculate the linear feet of stair, copy and paste the line "Total cost per LF of risers" and type the quantity.

03 Concrete

	Craft@Hrs	Unit	Material	Labor	Total
Concrete Accessories					
Bentonite					
50 pound bag, granules	—	Ea	80.00	—	80.00
3 gallon Volclay Bentoseal	—	Ea	198.00	—	198.00
4' x 15' Bentonite geotextile roll	—	Ea	159.00	—	159.00
Bond breaker and form release, SpecStrip					
Lumber & plywood form release, 1,000 SF/gal	CL@.006	SF	.02	.25	.27
Metal form release, 2,000 SF per gallon	CL@.003	SF	.01	.12	.13
Casting bed form breaker, 1,500 SF per gallon	CL@.005	SF	.01	.21	.22
Cure coat, 1,600 SF per gallon	CL@.005	SF	.01	.21	.22
Chamfer strip					
3/4" x 3/4" x 1", 10' lengths	CC@.015	LF	.74	.80	1.54
Chamfer corner forms					
3/4" corner forms	CC@.015	LF	33.00	.80	33.80
Column clamps single bar, per set, by column size,					
10" x 10" to 24" x 24", purchase	—	Set	189.00	—	189.00
24" x 24" to 36" x 36", purchase	—	Set	211.00	—	211.00
32" x 32" to 48" x 48", purchase	—	Set	291.00	—	291.00
Monthly rental cost as % of purchase price	—	%	10.0	—	—
Scissor column clamps for lumber forms, per set, by column size					
10" x 10" to 24" x 24", purchase	—	Set	200.00	—	200.00
12" x 12" to 36" x 36", purchase	—	Set	240.00	—	240.00
24" x 24" to 48" x 48", purchase	—	Set	284.00	—	284.00
Monthly rental cost as % of purchase price	—	%	10.0	—	—
Concrete sleeves, circular polyethylene liner, any slab thickness					
1-1/2" to 3" diameter	—	Ea	3.47	—	3.47
4" to 6" diameter	—	Ea	6.53	—	6.53
Embedded iron, installation only	C8@.045	Lb	—	2.14	2.14
Expansion joints, cane fiber, asphalt impregnated, pre-molded					
1/2" x 4", slabs	C8@.028	LF	1.66	1.33	2.99
1/2" x 6", in walls	C8@.035	LF	2.34	1.67	4.01
1/2" x 8", in walls	C8@.052	LF	2.95	2.48	5.43
Concrete footing form wedge ties					
6" wall thickness, pack of 250	—	Pack	126.00	—	126.00
8" wall thickness, pack of 250	—	Pack	132.00	—	132.00
Tie wedge, pack of 500	—	Pack	124.00	—	124.00
Form spreaders, 4" to 10"	—	Ea	.57	—	.57
Form oil, 800 to 1,200 SF per gallon	—	Gal	15.50	—	15.50
Grout for machine bases, mixed and placed. Add for edge forms, if required.					
Five Star epoxy					
per SF for each 1" of thickness	C8@.170	SF	18.10	8.09	26.19
Five Star NBEC non-shrink, non-metallic					
per SF for each 1" of thickness	C8@.170	SF	4.13	8.09	12.22
Embeco 636, metallic aggregate					
per SF for each 1" of thickness	C8@.163	SF	9.43	7.76	17.19
Forms for grout, based on using 2" x 4" lumber, 1 use					
	C8@.195	LF	6.46	9.28	15.74
Inserts, Unistrut, average	C8@.068	Ea	12.10	3.24	15.34
She bolt form clamps, with cathead and bolt, purchase					
17" rod	—	Ea	7.07	—	7.07
21" rod	—	Ea	11.70	—	11.70

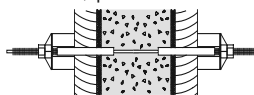
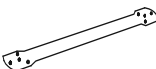
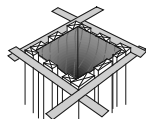
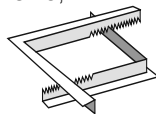

03 Concrete

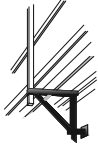
	Craft@Hrs	Unit	Material	Labor	Total
24" rod	—	Ea	12.70	—	12.70
Monthly rental as % of purchase price	—	%	15.0	—	—
Snap ties, average, 4,000 pound, 6" to 10"	—	Ea	.77	—	.77
Water stop, 3/8"					
Rubber, 6"	C8@.059	LF	.31	2.81	3.12
Rubber, 9"	C8@.059	LF	.19	2.81	3.00
Concrete waler brackets					
2" x 4"	—	Ea	12.30	—	12.30
2" x 6"	—	Ea	14.00	—	14.00
Waler jacks (scaffold support on form), purchase	—	Ea	67.10	—	67.10
Rental per month, each	—	Mo	8.12	—	8.12
Concrete Slab Finishes					
Float finish	CM@.009	SF	—	.47	.47
Trowel finishing					
Steel, machine work	CM@.014	SF	—	.73	.73
Steel, hand work	CM@.017	SF	—	.88	.88
Broom finish	CM@.012	SF	—	.62	.62
Scoring concrete surface, hand work	CM@.005	LF	—	.26	.26
Exposed aggregate (washed, including finishing), no disposal of slurry	CM@.015	SF	.39	.78	1.17
Color hardener, nonmetallic, trowel application					
Standard colors	—	Lb	1.24	—	1.24
Non standard colors	—	Lb	1.57	—	1.57
Light duty floors (40 pounds per 100 SF)	CM@.008	SF	—	.41	.41
Pastel shades (60 pounds per 100 SF)	CM@.012	SF	—	.62	.62
Heavy duty (90 pounds per 100 SF)	CM@.015	SF	—	.78	.78
Add for colored wax, 800 SF per gal	CM@.003	SF	.03	.16	.19
Sidewalk grits, abrasive, 25 pounds per 100 SF					
Aluminum oxide 100 pound bag	CM@.008	SF	.26	.41	.67
Silicon carbide, 100 pound bag	CM@.008	SF	.73	.41	1.14
Metallic surface hardener, dry shake, Masterplate 200					
Moderate duty, 1 pound per SF	CM@.008	SF	1.09	.41	1.50
Heavy duty, 1.5 pounds per SF	CM@.009	SF	1.72	.47	2.19
Concentrated traffic, 2 pounds per SF	CM@.010	SF	2.28	.52	2.80
Liquid curing and sealing compound, silicate based, 200 SF per gallon	CL@.004	SF	.25	.17	.42
Sweep, scrub and wash down	CL@.006	SF	.04	.25	.29
Finish treads and risers					
No abrasives, no plastering, per SF of tread	CM@.038	SF	—	1.97	1.97
With abrasives, plastered, per SF of tread	CM@.058	SF	.81	3.01	3.82
Wax coating	CL@.002	SF	.05	.08	.13
Concrete Wall Finishes					
Cut back ties and patch	CM@.010	SF	.16	.52	.68
Remove fins	CM@.007	LF	.05	.36	.41
Grind smooth	CM@.020	SF	.10	1.04	1.14
Sack, simple	CM@.012	SF	.06	.62	.68
Bush hammer light, green concrete	CM@.020	SF	.05	1.04	1.09
Bush hammer standard, cured concrete	CM@.029	SF	.07	1.50	1.57
Bush hammer, heavy, cured concrete	CM@.077	SF	.11	3.99	4.10

03 Concrete

	Craft@Hrs	Unit	Material	Labor	Total
Needle gun treatment, large areas	CM@.058	SF	.16	3.01	3.17
Wire brush, green	CM@.014	SF	.06	.73	.79
Wash with acid and rinse	CM@.004	SF	.24	.21	.45
Break fins, patch voids, Carborundum rub	CM@.032	SF	.07	1.66	1.73
Break fins, patch voids, burlap grout rub	CM@.024	SF	.08	1.24	1.32
Sandblasting, Subcontract. No scaffolding included, flat vertical surfaces					
Light sandblast	—	SF	—	—	2.37
Medium, to expose aggregate	—	SF	—	—	2.71
Heavy, with dust control requirements	—	SF	—	—	3.82
Note: Minimum charge for sandblasting	—	LS	—	—	1,000.00

Miscellaneous Concrete Finishes

Monolithic natural aggregate topping

1/16" topping	P9@.006	SF	.28	.29	.57
3/16" topping	P9@.018	SF	.63	.88	1.51
1/2" topping	P9@.021	SF	1.60	1.03	2.63
Integral colors,					
Typically 8 pounds per sack of cement	—	Lb	2.98	—	2.98
Mono rock, 3/8" wear course only, typical cost	—	SF	1.88	—	1.88
Kalman 3/4", wear course only, typical cost	—	SF	2.88	—	2.88
Acid etching, 5% muriatic acid, typical cost	P9@.005	SF	.53	.25	.78
Felton sand, for use with white cement	—	CY	60.00	—	60.00

Specially Placed Concrete Typical subcontract prices.

Gunite, no forms and no reinforcing included

Flat plane, vertical areas, 1" thick	—	SF	—	—	5.50
Curved arch, barrel, per 1" thickness	—	SF	—	—	6.84
Pool or retaining walls, per 1" thickness	—	SF	—	—	5.26
Add for architectural finish	—	SF	—	—	2.09
Wire mesh for gunite 2" x 2", W.9 x W.9	—	SF	—	—	2.42
Pressure grouting, large quantity, 50/50 mix	—	CY	—	—	861.00

Precast Concrete Panel costs are based on 3,000 PSI natural gray concrete with a smooth or board finish on one side. Placing (lifting) costs include handling, hoisting, alignment, bracing and permanent connections. Erection costs vary with the type of crane. Heavier lifts over a longer radius (reach) require larger cranes. Equipment costs include the crane and a 300 amp gas powered welding machine. Add the cost of grouting or caulking joints. Costs will be higher on small jobs (less than 35,000 SF).

	Craft@Hrs	Unit	Material	Labor	Equipment	Total
Precast wall panels Costs include delivery to 40 miles, typical reinforcing steel and embedded items but no lifting. Use 2,500 SF as a minimum job charge. See placing costs below.						
4" thick wall panels (52 lbs per SF)	—	SF	16.70	—	—	16.70
5" thick wall panels (65 lbs per SF)	—	SF	18.30	—	—	18.30
6" thick wall panels (78 lbs per SF)	—	SF	19.90	—	—	19.90
8" thick wall panels (105 lbs per SF)	—	SF	21.00	—	—	21.00
Add for insulated sandwich wall panels						
2-1/2" of cladding and 2" of fiberboard	—	SF	7.13	—	—	7.13
Add for high strength concrete						
3,500 lb concrete mix	—	%	2.0	—	—	—
4,000 lb concrete mix	—	%	3.0	—	—	—
4,500 lb concrete mix	—	%	4.0	—	—	—
5,000 lb concrete mix	—	%	6.0	—	—	—
Add for white facing or integral white mix	—	%	20.0	—	—	—
Add for broken rib						
or fluted surface design	—	%	20.0	—	—	—
Add for exposed aggregate finish	—	%	17.0	—	—	—
Add for sandblasted surface finish	—	%	12.0	—	—	—

03 Concrete

Craft@Hrs Unit Material Labor Equipment Total

Placing precast structural wall panels Figures in parentheses show the panels placed per day with a 100 ton crawler-mounted crane and welding machine. Use \$9,000 as a minimum job charge.

1 ton panels to 180' reach (23 per day)	H4@2.79	Ea	—	176.00	110.00	286.00
1 to 3 tons, to 121' reach (21 per day)	H4@3.05	Ea	—	192.00	121.00	313.00
3 to 5 tons, to 89' reach (18 per day)	H4@3.54	Ea	—	223.00	140.00	363.00
5 to 7 tons, to 75' reach (17 per day)	H4@3.76	Ea	—	237.00	149.00	386.00
7 to 9 tons, to 65' reach (16 per day)	H4@4.00	Ea	—	252.00	158.00	410.00
9 to 11 tons, to 55' reach (15 per day)	H4@4.28	Ea	—	270.00	169.00	439.00
11 to 13 tons, to 50' reach (14 per day)	H4@4.56	Ea	—	288.00	180.00	468.00
13 to 15 tons, to 43' reach (13 per day)	H4@4.93	Ea	—	311.00	195.00	506.00
15 to 20 tons, to 36' reach (11 per day)	H4@5.81	Ea	—	366.00	230.00	596.00
20 to 25 tons to 31' reach (10 per day)	H4@6.40	Ea	—	404.00	253.00	657.00
For placing panels with cladding, add	—	%	—	5.0	5.0	—
For placing sandwich wall panels, add	—	%	—	10.0	10.0	—
If a 45 ton crane can be used, deduct	—	%	—	—	-22.0	—

Placing precast partition wall panels Figures in parentheses show the panels placed per day with a 45 ton truck-mounted crane and welding machine. Use \$6,000 as a minimum job charge.

1 ton panels to 100' reach (23 per day)	H4@2.79	Ea	—	176.00	90.10	266.10
1 to 2 tons, to 82' reach (21 per day)	H4@3.05	Ea	—	192.00	98.50	290.50
2 to 3 tons, to 65' reach (18 per day)	H4@3.54	Ea	—	223.00	114.00	337.00
3 to 4 tons, to 57' reach (16 per day)	H4@4.00	Ea	—	252.00	129.10	381.10
4 to 5 tons, to 50' reach (15 per day)	H4@4.28	Ea	—	270.00	138.00	408.00
5 to 6 tons, to 44' reach (14 per day)	H4@4.56	Ea	—	288.00	147.00	435.00
6 to 7 tons, to 40' reach (13 per day)	H4@4.93	Ea	—	311.00	159.00	470.00
7 to 8 tons, to 36' reach (11 per day)	H4@5.81	Ea	—	366.00	188.00	554.00
8 to 10 tons, to 31' reach (10 per day)	H4@6.40	Ea	—	404.00	207.00	611.00
10 to 12 tons to 26' reach (9 per day)	H4@7.11	Ea	—	448.00	230.00	678.00
12 to 14 tons, to 25' reach (8 per day)	H4@8.02	Ea	—	506.00	259.00	765.00
14 to 16 tons, to 21' reach (7 per day)	H4@9.14	Ea	—	576.00	295.00	871.00
If a 35 ton crane can be used, deduct	—	%	—	—	-5.0	—

Precast flat floor slab or floor plank Costs include delivery to 40 miles, 3,000 PSI concrete, typical reinforcing steel and embedded items. Use \$2,000 as a minimum job charge. See placing costs below.

4" thick floor panels (52 lbs per SF)	—	SF	14.00	—	—	14.00
5" thick floor panels (65 lbs per SF)	—	SF	16.60	—	—	16.60
6" thick floor panels (78 lbs per SF)	—	SF	21.20	—	—	21.20
8" thick floor panels (105 lbs per SF)	—	SF	22.10	—	—	22.10

Placing panels with a 100 ton crawler-mounted crane and welding machine at \$775 per day. Figures in parentheses show the number of panels placed per day. Use \$8,500 as a minimum job charge

2 ton panels to 150' reach (23 per day)	H4@2.79	Ea	—	176.00	68.10	244.10
2 to 3 tons, to 121' reach (21 per day)	H4@3.05	Ea	—	192.00	74.50	266.50
3 to 4 tons, to 105' reach (19 per day)	H4@3.37	Ea	—	213.00	82.40	295.40
4 to 5 tons, to 88' reach (18 per day)	H4@3.56	Ea	—	225.00	87.00	312.00
5 to 6 tons, to 82' reach (17 per day)	H4@3.76	Ea	—	237.00	91.90	328.90
6 to 7 tons, to 75' reach (16 per day)	H4@4.00	Ea	—	252.00	97.70	349.70
7 to 8 tons, to 70' reach (15 per day)	H4@4.28	Ea	—	270.00	105.00	375.00
8 to 9 tons, to 65' reach (14 per day)	H4@4.56	Ea	—	288.00	112.00	400.00
9 to 10 tons, to 60' reach (11 per day)	H4@5.82	Ea	—	367.00	142.00	509.00
20 to 25 tons, to 31' reach (10 per day)	H4@6.40	Ea	—	404.00	156.00	560.00

03 Concrete

Craft@Hrs Unit Material Labor Equipment Total

Precast combination beam and slab units Beam and slab units with beam on edge of slab. Weight of beams and slabs will be about 4,120 lbs per CY. Use 40 CY as a minimum job charge. See placing costs below.

Slabs with no intermediate beam	—	CY	1,120.00	—	—	1,120.00
Slabs with one intermediate beam	—	CY	1,190.00	—	—	1,190.00
Slabs with two intermediate beams	—	CY	1,300.00	—	—	1,300.00

Placing deck units with a 100 ton crawler-mounted crane and a welding machine. Figures in parentheses show the number of units placed per day. Use \$8,500 as a minimum job charge.

5 ton units to 88' reach (21 per day)	H4@3.05	Ea	—	192.00	74.50	266.50
5 to 10 tons, to 60' reach (19 per day)	H4@3.37	Ea	—	213.00	82.40	295.40
10 to 15 tons, to 43' reach (17 per day)	H4@3.76	Ea	—	237.00	91.90	328.90
15 to 20 tons, to 36' reach (15 per day)	H4@4.28	Ea	—	270.00	105.00	375.00
20 to 25 tons, to 31' reach (14 per day)	H4@4.57	Ea	—	288.00	112.00	400.00
If a 150 ton crane is required, add	—	%	—	—	16.0	—

Precast beams, girders and joists Beams, girders and joists, costs per linear foot of span, including 3,000 PSI concrete, reinforcing steel, embedded items and delivery to 40 miles. Use 400 LF as a minimum job charge. See placing costs below.

1,000 lb load per foot, 15' span	—	LF	136.00	—	—	136.00
1,000 lb load per foot, 20' span	—	LF	151.00	—	—	151.00
1,000 lb load per foot, 30' span	—	LF	172.00	—	—	172.00
3,000 lb load per foot, 10' span	—	LF	136.00	—	—	136.00
3,000 lb load per foot, 20' span	—	LF	172.00	—	—	172.00
3,000 lb load per foot, 30' span	—	LF	208.00	—	—	208.00
5,000 lb load per foot, 10' span	—	LF	136.00	—	—	136.00
5,000 lb load per foot, 20' span	—	LF	189.00	—	—	189.00
5,000 lb load per foot, 30' span	—	LF	225.00	—	—	225.00

Placing beams, girders and joists with a 100 ton crawler-mounted crane and a welding machine. Figures in parentheses show the number of units placed per day. Use \$8,500 as a minimum job charge.

5 ton units to 88' reach (18 per day)	H4@3.56	Ea	—	225.00	87.00	312.00
5 to 10 tons, to 60' reach (17 per day)	H4@3.76	Ea	—	237.00	91.90	328.90
10 to 15 tons, to 43' reach (16 per day)	H4@4.00	Ea	—	252.00	97.70	349.70
15 to 20 tons, to 36' reach (15 per day)	H4@4.27	Ea	—	269.00	104.00	373.00
If a 150 ton crane is required, add	—	%	—	—	16.0	—

Precast concrete columns Precast concrete columns, 12" x 12" to 36" x 36" including concrete, reinforcing steel, embedded items and delivery to 40 miles. Use 40 CY as a minimum job charge. See placing costs below.

Columns with 500 lbs of reinforcement per CY	—	CY	1,170.00	—	—	1,170.00
Columns with 350 lbs of reinforcement per CY	—	CY	1,150.00	—	—	1,150.00
Columns with 200 lbs of reinforcement per CY	—	CY	1,120.00	—	—	1,120.00

Placing concrete columns with a 100 ton crawler-mounted crane and a welding machine. Figures in parentheses show the number of units placed per day. Use \$8,500 as a minimum job charge.

3 ton columns to 121' reach (29 per day)	H4@2.21	Ea	—	139.00	53.60	192.60
3 to 5 tons, to 89' reach (27 per day)	H4@2.37	Ea	—	149.00	57.90	206.90
5 to 7 tons, to 75' reach (25 per day)	H4@2.55	Ea	—	161.00	62.30	223.30
7 to 9 tons, to 65' reach (23 per day)	H4@2.79	Ea	—	176.00	68.10	244.10
9 to 11 tons, to 55' reach (22 per day)	H4@2.92	Ea	—	184.00	71.40	255.40
11 to 13 tons, to 50' reach (20 per day)	H4@3.20	Ea	—	202.00	78.20	280.20
13 to 15 tons, to 43' reach (18 per day)	H4@3.56	Ea	—	225.00	87.00	312.00

03 Concrete

Craft@Hrs Unit Material Labor Equipment Total

Precast concrete stairs Costs include concrete, reinforcing, embedded steel, nosing, and delivery to 40 miles. Use \$500 as a minimum job charge. See placing costs below.

Stairs, 44" to 48" wide, 10' to 12' rise, "U"- or "L"-shape, including typical landings,

Cost per each step (7" rise)	—	Ea	66.90	—	—	66.90
------------------------------	---	----	-------	---	---	-------

Placing precast concrete stairs with a 45 ton truck-mounted crane and a welding machine. Figures in parentheses show the number of stair flights placed per day. Use \$6,000 as a minimum job charge.

2 ton stairs to 82' reach (21 per day)	H4@3.05	Ea	—	192.00	98.50	290.50
2 to 3 tons, to 65' reach (19 per day)	H4@3.37	Ea	—	213.00	109.00	322.00
3 to 4 tons, to 57' reach (18 per day)	H4@3.54	Ea	—	223.00	114.00	337.00
4 to 5 tons, to 50' reach (17 per day)	H4@3.76	Ea	—	237.00	122.00	359.00
5 to 6 tons, to 44' reach (16 per day)	H4@4.00	Ea	—	252.00	129.00	381.00
6 to 7 tons, to 40' reach (15 per day)	H4@4.28	Ea	—	270.00	138.00	408.00
7 to 8 tons, to 36' reach (14 per day)	H4@4.56	Ea	—	288.00	147.00	435.00
8 to 9 tons, to 33' reach (10 per day)	H4@6.40	Ea	—	404.00	207.00	611.00
If a 35 ton crane can be used, deduct	—	%	—	—	-10.0	—

Precast double tees 8' wide, 24" deep. Design load is shown in pounds per square foot (PSF). Costs include lifting and placing but no slab topping. Equipment cost is for a 45 ton truck crane and a welding machine. Use \$6,000 as a minimum job charge.

30' to 35' span, 115 PSF	H4@.019	SF	15.30	1.20	.61	17.11
30' to 35' span, 141 PSF	H4@.019	SF	16.80	1.20	.61	18.61
35' to 40' span, 78 PSF	H4@.018	SF	15.30	1.14	.58	17.02
35' to 40' span, 98 to 143 PSF	H4@.018	SF	16.80	1.14	.58	18.52
40' to 45' span, 53 PSF	H4@.017	SF	15.30	1.07	.55	16.92
40' to 45' span, 69 to 104 PSF	H4@.017	SF	16.80	1.07	.55	18.42
40' to 45' span, 134 PSF	H4@.017	SF	17.60	1.07	.55	19.22
45' to 50' span, 77 PSF	H4@.016	SF	16.80	1.01	.52	18.33
45' to 50' span, 101 PSF	H4@.016	SF	17.60	1.01	.52	19.13

Concrete topping, based on 350 CY job 3,000 PSI design mix with lightweight aggregate, no forms or finishing included.

By crane	H3@.868	CY	133.00	41.00	23.60	197.60
By pump (28 meter boom truck and operator)	M2@.080	CY	145.00	3.65	7.47	156.12

Hollow core roof planks, not including topping, 35 PSF live load, 10' to 15' span

4" thick	H4@.018	SF	8.00	1.14	.37	9.51
6" thick	H4@.018	SF	9.76	1.14	.37	11.27
8" thick	H4@.020	SF	11.50	1.26	.41	13.17
10" thick	H4@.026	SF	11.90	1.64	.53	14.07

Prestressed concrete support poles Costs shown are per linear foot for sizes and lengths shown. Equipment cost is for a 45 ton truck crane. These costs do not include base or excavation. Lengths other than as shown will cost more per foot. Use \$6,000 as a minimum job charge.

10" x 10" poles with four 7/16" 270 KSI ultimate tendon strand strength

10', 14', 20', 25' or 30' long	H4@.028	LF	21.60	1.77	.87	24.24
--------------------------------	---------	----	-------	------	-----	-------

12" x 12" poles with six 7/16" 270 KSI ultimate tendon strand strength

10', 14' or 20' long	H4@.028	LF	26.10	1.77	.87	28.74
25' or 30' long	H4@.028	LF	29.20	1.77	.87	31.84

Tilt-up concrete construction Costs will be higher if access is not available from all sides or obstructions delay the work. Except as noted, no grading, compacting, engineering, design, permit or inspection fees are included.

03 Concrete

	Craft@Hrs	Unit	Material	Labor	Equipment	Total
Foundations and footings for tilt-up Costs assume normal soil conditions with no forming or shoring required and are based on concrete poured directly from the chute of a ready-mix truck. Soil excavated and not needed for backfill can be stored on site and used by others. For scheduling purposes, estimate that a crew of 5 can set forms for and pour 40 to 50 CY of concrete footings and foundations in an 8-hour day.						
Lay out foundation from known point on site, set stakes and mark for excavation.						
Per SF of floor slab	C8@.001	SF	—	.05	—	.05
Excavation with a 1/2 CY utility backhoe						
27 CY per hour	S1@.075	CY	—	3.73	1.70	5.43
Set and tie grade A60 reinforcing bars, typical foundation has 50 to 60 pounds of reinforcing bar per CY of concrete						
	RB@.008	Lb	.82	.53	—	1.35
Place stringer supports for reinforcing bars (at 1.1 LF of support per LF of rebar), using 2" x 4" or 2" x 6" lumber. Includes typical stakes and hardware						
Based on 3 uses of supports	C8@.017	LF	1.05	.81	—	1.86
(Inspection of reinforcing may be required before concrete is placed.)						
Make and place steel column anchor bolt templates (using 1.1 SF of plywood per SF of column base). Based on 3 uses of 3/4" plyform. If templates are furnished by the steel column fabricator, include only the labor cost to place the templates as shown						
Make and place templates	C8@.160	SF	1.56	7.62	—	9.18
Place templates furnished by others	C8@.004	SF	—	.19	—	.19
Blockout form at foundation, step footings, columns, etc., per SF of contact area, using 2" x 6" lumber. Includes allowance for waste, typical stakes and hardware.						
Based on 3 uses of forms	C8@.018	SFCA	3.74	.86	—	4.60
Column anchor bolts, usually 4 per column. "J"-hook bolt includes flat washer and two nuts						
1/2" x 6"	C8@.037	Ea	1.94	1.76	—	3.70
3/4" x 12"	C8@.037	Ea	5.77	1.76	—	7.53
Concrete, 2,000 PSI design mix, including 3% allowance for waste,						
Placed directly from chute	CL@.552	CY	126.00	23.00	—	149.00
Remove, clean and stack reinforcing supports						
	CL@.020	LF	—	.83	—	.83
Dry pack non-shrink grout under column bases. Typical grout area is						
2' x 2' x 4" (1.33 CF of grout)	CM@.625	Ea	50.10	32.40	—	82.50
Panel support pads. (Supports panel when grout is placed.) One needed per panel. Based on						
3 CF of 2,000 PSI concrete per pad	C8@.141	Ea	14.00	6.71	—	20.71
Backfill at foundation with 1/2 CY utility backhoe.						
90 CY per hour	S1@.022	CY	—	1.09	.50	1.59
Dispose of excess soil on site, using backhoe						
	S1@.011	CY	—	.55	.25	.80
Concrete test cylinders, typically 5 required						
per 100 CY of concrete	—	CY	1.25	—	—	1.25
Floor slabs for tilt-up These costs assume that the site has been graded and compacted by others before slab work begins. The costs below include fine grading the site, placing a 2" layer of sand, a vapor barrier and a second 2" layer of sand over the barrier. Each layer of sand should be screeded level. Reinforcing may be either wire mesh or bars. When sand and vapor barrier are used, concrete may have to be pumped in place. If inspection of the reinforcing is required, the cost will usually be included in the building permit fee. Floor slabs are usually poured 6" deep in 14' to 18' wide strips with edge forms on both sides and ends. Edge forms are used as supports for the mechanical screed which consolidates the concrete with pneumatic vibrators as the surface is leveled. The screed is pulled forward by a winch and cable. Edge forms should have an offset edge to provide a groove which is filled by the adjacent slab. The slab perimeter should end 2' to 3' inside the finished building walls. This "pour strip" is filled in with concrete when the walls are up and braces have been removed. About 2 days after pouring, the slab should be saw-cut 1-1/2" to 2" deep and 1/4" wide each 20' both ways. This controls cracking as the slab cures. For scheduling purposes, estimate that a finishing crew of 10 workers can place and finish 10,000 to 12,000 square feet of slab in 8 hours.						
Fine grade the building pad with a utility tractor with blade and bucket						
2,500 SF per hour	S6@.001	SF	—	.05	.01	.06

03 Concrete

	Craft@Hrs	Unit	Material	Labor	Equipment	Total
Spread sand 4" deep in 2" layers, (1.35 tons is 1 cubic yard and covers 81 SF at 4" depth), using a utility tractor						
Cost of sand	—	Ton	28.90	—	—	28.90
60 SF per hour	S6@.006	SF	.48	.28	.08	.84
Vapor barrier, 6 mil polyethylene	CL@.001	SF	.08	.04	—	.12
Welded wire mesh, 6" x 6", W1.4 x W1.4 including 10% for overlap and waste						
	RB@.004	SF	.29	.26	—	.55
Reinforcing bars, grade 60, typically #4 bars on 2' centers each way with 1.05 LF bars per SF						
	RB@.004	SF	.65	.26	—	.91
Dowel out for #4 bars at construction joints						
	RB@.004	LF	.40	.26	—	.66
Edge forms with keyed joint, rented						
	F5@.013	LF	—	.63	.09	.72
Ready-mix concrete for the slab (with 3% waste allowance)						
Placed from the chute of the ready-mix truck						
	CL@.421	CY	137.00	17.50	—	154.50
Pump mix, including pumping cost	M2@.188	CY	151.00	8.58	12.90	172.48
Finish the floor slab, using power trowels	CM@.003	SF	—	.16	.04	.20
Vibrating screed and accessories, (includes screeds, fuel, air compressor and hoses) rented Per SF of slab						
	—	SF	—	—	.13	.13
Curing compound, spray applied, 250 SF per gallon						
	CL@.001	SF	.20	.04	—	.24
Saw cut green concrete, 1-1/2" to 2" deep						
	C8@.010	LF	—	.48	.13	.61
Strip, clean and stack edge forms						
	CL@.011	LF	—	.46	—	.46
Ready-mix concrete for the pour strip including 3% waste						
Placed from the chute of the ready-mix truck						
	CL@.421	CY	137.00	17.50	—	154.50
Pump mix, including pumping cost	M2@.188	CY	151.00	8.58	12.90	172.48
Finish the pour strip	CM@.004	SF	—	.21	.04	.25
Special inspection of the concrete pour (if required) Based on 10,000 SF in 8 hours						
	—	SF	—	—	—	.04
Clean and caulk the saw joints, based on 50 LF per hour and caulk and 1,500 LF per gallon						
	CL@.020	LF	.06	.83	—	.89
Clean slab (broom clean)						
	CL@.001	SF	—	.04	—	.04

Tilt-up wall panels Wall thickness is usually a nominal 6" (5-1/2" actual) or a nominal 8" (7-1/2"). Panel heights over 40' are uncommon. Typical panel width is 20'. When the floor area isn't large enough to form all wall panels on the floor slab, stacking will be required. Construction period will be longer and the costs higher than the figures shown below when panels must be poured and cured in stacked multiple layers. When calculating the volume of concrete required, the usual practice is to multiply overall panel dimensions (width, length and thickness) and deduct only for panel openings that exceed 25 square feet. When pilasters (thickened wall sections) are formed as part of the panel, add the cost of extra formwork and the additional concrete. Use the production rates that follow for scheduling a job.

03 Concrete

Production rates for tilt-up

Lay out and form panels, place reinforcing bars and install embedded lifting devices:

2,000 to 3,000 SF of panel face (measured one side) per 8-hour day for a crew of 5. Note that reinforcing may have to be inspected before concrete is poured.

Place and finish concrete: 4,000 to 5,000 SF of panel per 8-hour day for a crew of 5.

Continuous inspection of the concrete pour by a licensed inspector may be required.

The minimum charge will usually be 4 hours at \$50 per hour plus travel cost.

Install ledgers with embedded anchor bolts on panels before the concrete hardens:

150 to 200 LF of ledger per 8-hour day for a crew of 2.

Sack and patch exposed panel face before panel is erected:

2,000 to 3,000 SF of panel face per 8-hour day for a crew of 2.

Install panel braces before lifting panels:

30 to 40 braces per 8-hour day for a crew of 2. Panels usually need 3 or 4 braces. Braces are usually rented for 30 days.

Tilt up and set panels 20 to 24 panels per 8-hour day for a crew of 11 (6 workers, the crane operator, oiler and 3 riggers). If the crew sets 22 panels averaging 400 SF each in an 8-hour day, the crew is setting 1,100 SF per hour. These figures include time for setting and aligning panels, drilling the floor slab for brace bolts, and securing the panel braces. Panel tilt-up will go slower if the crane can't work from the floor slab when lifting panels. Good planning of the panel lifting sequence and easy exit of the crane from the building interior will increase productivity. Size and weight of the panel has little influence on the setting time if the crane is capable of making the lift and is equipped with the right rigging equipment, spreader bars and strongbacks. Panels will usually have to cure for 14 days before lifting unless high early strength concrete is used.

Weld or bolt steel embedded in panels: 16 to 18 connections per 8-hour day for a crew of 2 working from ladders. Work more than 30 feet above the floor may take more time.

Sack and patch panel faces after erection: 400 SF of face per 8-hour day for a crew of 2.

	Craft@Hrs	Unit	Material	Labor	Equipment	Total
Tilt-up panel costs						
Engineering fee, per panel, typical	—	Ea	—	—	—	56.60
Fabricate and lay out forms for panel edges and blockouts, assumes 3 uses and includes typical hardware and chamfer						
2" x 6" per MBF	—	MBF	1,260.00	—	—	1,260.00
2" x 8" per MBF	—	MBF	1,110.00	—	—	1,110.00
2" x 6" per LF	F5@.040	LF	.75	1.95	—	2.70
2" x 8" per LF	F5@.040	LF	.90	1.95	—	2.85
Reveals (1" x 2" accent strips on exterior panel face)						
Based on 1 use of lumber						
Nailed to slab	C8@.018	LF	.26	.86	—	1.12
Clean and prepare the slab prior to placing the concrete for the panels,						
1,250 SF per hour	CL@.001	SF	—	.04	—	.04
Releasing agent (bond breaker), sprayed on,						
250 SF	CL@.001	SF	.02	.04	—	.06
Place and tie grade 60 reinforcing bars and supports. Based on using #3 and #4 bars, including waste and laps. A typical panel has 80 to 100 pounds of reinforcing steel per CY of concrete in the panel						
Reinforcing per CY of concrete	RB@.500	CY	62.90	32.90	—	95.80
Reinforcing per SF of 6" thick panel	RB@.009	SF	1.16	.59	—	1.75
Reinforcing per SF of 8" thick panel	RB@.012	SF	1.55	.79	—	2.34
Ledger boards with anchor bolts. Based on 4" x 12" treated lumber and 3/4" x 12" bolts placed each 2 feet, installed prior to lifting panel						
Using 4" x 12" treated lumber	—	MBF	2,130.00	—	—	2,130.00
Typical ledgers and anchor bolts	C8@.353	LF	11.50	16.80	—	28.30

03 Concrete

	Craft@Hrs	Unit	Material	Labor	Equipment	Total
Embedded steel for pickup and brace point hardware. Usually 10 to 12 points per panel, quantity and type depend on panel size						
Embedded pickup & brace hardware, typical	C8@.001	SF	1.02	.05	—	1.07
Note: Inspection of reinforcing may be required before concrete is placed.						
Concrete, 3,000 PSI, placed direct from chute						
Concrete only (before waste allowance)	—	CY	133.00	—	—	133.00
6" thick panels (54 SF per CY)	CL@.008	SF	2.54	.33	.09	2.96
8" thick panels (40.5 SF per CY)	CL@.010	SF	3.38	.42	.12	3.92
Concrete, 3,000 PSI, pumped in place						
Concrete only (before waste allowance)	—	CY	146.00	—	—	146.00
6" thick panels (54 SF per CY)	M2@.008	SF	2.79	.36	.03	3.18
8" thick panels (40.5 SF per CY)	M2@.011	SF	3.72	.50	.04	4.26
Finish concrete panels,						
one face before lifting	P8@.004	SF	—	.19	.02	.21
Continuous inspection of pour, if required, based on 5,000 to 6,000 SF being placed per 8-hour day						
Typical cost						
for continuous inspection of pour	—	SF	—	—	—	.10
Curing wall panels with spray-on curing compound, per SF of face,						
based on 250 SF per gallon	CL@.001	SF	.20	.04	—	.24
Strip, clean and stack 2" edge forms	CL@.030	LF	—	1.25	—	1.25
Braces for panels						
Install rented panel braces, based on an average of three braces per panel for panels averaging 400 to 500 SF each.						
See also, Remove panel braces						
Typical cost for braces,						
per SF of panel	F5@.005	SF	—	.24	.19	.43
Miscellaneous equipment rental, typical costs per SF of wall panel						
Rent power trowels and vibrators	—	SF	—	—	.13	.12
Rent compressors, hoses, rotohammers, fuel	—	SF	—	—	.13	.12
Lifting panels into place, with crane and riggers, using a 140 ton truck crane						
Move crane on and off site, typical	—	LS	—	—	3,630.00	3,630.00
Hourly cost (4 hr minimum applies), per hour	T2@11.0	Hr	—	590.00	606.00	1,196.00
Set, brace and align panels, per SF of panel measured on one face, Based on 1,100 SF per hour	T2@.010	SF	—	.54	.62	1.16
Allowance for shims, bolts for panel braces and miscellaneous hardware, labor cost is included with associated items						
Typical cost per SF of panel	—	SF	.52	—	—	.52
Weld or bolt panels together, typically 2 connections are required per panel, equipment is a welding machine.						
Typical cost per panel connection	T3@.667	Ea	116.00	35.80	3.61	155.41
Continuous inspection of welding, if required.						
Inspection of welds, per connection (3 per hour)	—	Ea	—	—	—	29.50
Set grout forms at exterior wall perimeter. Based on using 2" x 12" boards. Costs shown include stakes and assume 3 uses of the forms						
Using 2" x 12" boards (per MBF)	—	MBF	1,350.00	—	—	1,350.00
Cost of forms per linear foot (LF)	F5@.019	LF	1.44	.93	—	2.37
Pour grout under panel bottoms. Place 2,000 PSI concrete (grout) directly from the chute of ready-mix truck.						
Typically 1.85 CY per 100 LF of wall	M2@.005	LF	.23	.23	—	.46

03 Concrete

	Craft@Hrs	Unit	Material	Labor	Equipment	Total
Sack and patch wall, per SF of area (measure area to be sacked and patched, both inside and outside),						
per SF of wall face(s), before tilt-up	P8@.007	SF	.11	.33	—	.44
per SF of wall face(s), after tilt-up	P8@.040	SF	.11	1.87	—	1.98
Caulking and backing strip for panel joints. Cost per LF for caulking both inside & outside face of joint,						
per linear foot (LF) of joint	PA@.055	LF	.30	2.96	—	3.26
Remove panel braces,						
stack & load onto trucks	CL@.168	Ea	—	7.00	—	7.00
Final cleanup & patch floor,						
per SF of floor	P8@.003	SF	.01	.14	—	.15
Additional costs for tilt-up panels, if required						
Architectural form liner, minimum cost	F5@.001	SF	2.25	.05	—	2.30
Architectural form liner, typical cost	F5@.003	SF	2.75	.15	—	2.90
Sandblast, light and medium,						
subcontract	—	SF	—	—	—	2.54
Sandblast, heavy, subcontract	—	SF	—	—	—	3.82
Truck dock bumpers, installation only	C8@2.00	Ea	—	95.20	—	95.20
Dock levelers, installation only	C8@7.46	Ea	—	355.00	—	355.00
Angle iron guard around door opening,						
2" x 2" x 1/4", mild steel (4' lengths)	C8@.120	LF	3.42	5.71	—	9.13
Pipe guard at door opening,						
6" black steel, concrete filled	C8@.281	LF	39.80	13.40	—	53.20
Embedded reglet at parapet wall,						
aluminum	F5@.019	LF	1.63	.93	—	2.56
Integral color in concrete, light colors, add to concrete. Price per CY of						
concrete to be colored	—	CY	34.30	—	—	34.30
Backfill outside perimeter wall with a utility tractor.						
90 CY per hour	S1@.022	CY	—	1.09	.32	1.41

Cast-in-place columns for tilt-up Concrete columns are often designed as part of the entryway of a tilt-up building or to support lintel panels over a glass storefront. Both round and square freestanding columns are used. They must be formed and poured before the lintel panels are erected. Round columns are formed with plastic-treated fiber tubes (Sonotube is one manufacturer) that are peeled off when the concrete has cured. Square columns are usually formed with plywood and 2" x 4" wood braces or adjustable steel column clamps.

Heavy wall water-resistant fiber tube forms, set and aligned, based on 12' long tubes. Longer tubes will cost more per LF

12" diameter tubes	M2@.207	LF	3.72	9.44	—	13.16
20" diameter tubes	M2@.250	LF	8.80	11.40	—	20.20
24" diameter tubes	M2@.275	LF	12.10	12.50	—	24.60
Rectangular plywood forms, using 1.1 SF of 3/4" plyform and 2" x 4" bracing 3' OC						
Per SF of contact area						
based on 3 uses	F5@.083	SF	1.46	4.05	—	5.51
Column braces, 2" x 4" at \$768.00 per MBF, with 5 BF per LF of column height						
Per LF of column height						
based on 3 uses	F5@.005	LF	2.95	.24	1.77	4.96
Column clamps rented at \$5.00 for 30 days, 1 per LF of column height, cost per LF of column height						
Per LF of column						
based on 2 uses a month	F5@.040	LF	—	1.95	5.50	7.45
Reinforcing bars, grade 60, placed and tied, typically 150 to 200 pounds per CY of concrete						
Cages, round or rectangular	RB@1.50	CY	111.00	98.60	—	209.60
Vertical bars						
attached to cages	RB@1.50	CY	111.00	98.60	—	209.60
Ready-mix concrete, 3,000 PSI pump mix						
Placed by pump (includes 3% waste)	M2@.094	CY	145.00	4.29	8.42	157.71

03 Concrete

	Craft@Hrs	Unit	Material	Labor	Equipment	Total
Strip off fiber forms and dismantle bracing, per LF of height						
12" or 16" diameter	CL@.075	LF	—	3.12	—	3.12
24" diameter	CL@.095	LF	—	3.96	—	3.96
Strip wood forms and dismantle bracing						
Per SF of contact area, no salvage	CL@.011	SF	—	.46	—	.46
Clean and stack column clamps	CL@.098	Ea	—	4.08	3.84	7.92
Sack and patch concrete column face	P8@.011	SF	.18	.51	—	.69
Allowance for miscellaneous equipment rental (vibrators, compressors, hoses, etc.)						
Per CY of concrete in column	—	CY	—	—	2.50	2.50

Trash enclosures for tilt-up These usually consist of a 6" concrete slab measuring 5' x 10' and precast concrete tilt-up panels 6' high. A 6" ledger usually runs along the wall interior. Overall wall length is usually 20 feet. Cost for the trash enclosure foundation, floor slab and wall will be approximately the same as for the tilt-up foundation, floor slab and wall. The installed cost of a two-leaf steel gate measuring 6' high and 8' long overall will be about \$460 including hardware.

Equipment Foundations Except as noted, no grading, compacting, engineering, design, permit or inspection fees are included. Costs assume normal soil conditions with no shoring or dewatering required and are based on concrete poured directly from the chute of a ready-mix truck. Costs will be higher if access is not available from all sides or if obstructions delay the work.

Labor costs include the time needed to prepare formwork sketches at the job site, measure for the forms, fabricate, erect, align and brace the forms, place and tie the reinforcing steel and embedded steel items, pour and finish the concrete and strip, clean and stack the forms.

Reinforcing steel costs assume an average of #3 and #4 bars at 12" on center each way. Weights shown include an allowance for waste and laps.

Form costs assume 3 uses of the forms and show the cost per use when a form is used on the same job without being totally disassembled. Normal cleaning and repairs are included. No salvage value is assumed. Costs listed are per square foot of form in contact with the concrete, assume using #2 & Btr lumber

For scheduling purposes, estimate that a crew of 5 can set the forms and place and tie the reinforcing steel for and pour 8 to 10 CY of concrete equipment foundations in an 8-hour day.

Rule-of-thumb estimates The costs below are based on the volume of concrete in the foundation. If plans for the foundation have not been prepared, estimate the quantity of concrete required from the weight of the equipment using the rule-of-thumb estimating data below. Design considerations may alter the actual quantities required. Based on the type foundation required, use the cost per CY given in the detailed cost breakdown section which follows the table on the next page.

Estimating concrete quantity from the weight of equipment:

1. Rectangular pad type foundations —

Boilers and similar equipment mounted at grade:

 Allow 1 CY per ton

Centrifugal pumps and compressors, including weight of motor:

 Up to 2 HP, allow .5 CY per ton

 Over 2 to 10 HP, allow 1 CY per ton

 Over 10 to 30 HP, allow 2 CY per ton

 Over 30 HP, allow 3 CY per ton

Reciprocating pumps and compressors, including weight of motor:

 Up to 2 HP, allow .75 CY per ton

 Over 2 to 10 HP, allow 1.5 CY per ton

 Over 10 to 30 HP, allow 2.5 CY per ton

 Over 30 HP, allow 4.5 CY per ton

2. Rectangular pad and stem wall type foundations — Horizontal tanks or shell and tube heat exchangers, allow 6 CY per ton

3. Square pad and pedestal type foundations — Vertical tanks not over 3' in diameter, allow 6 CY per ton

4. Octagonal pad and pedestal type foundations — Vertical tanks over 3' in diameter, allow 4 CY per ton of empty weight

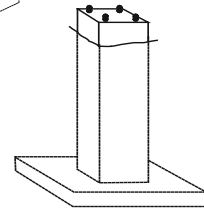
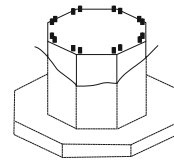
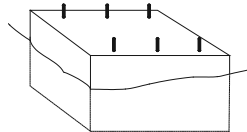

03 Concrete

	Craft@Hrs	Unit	Material	Labor	Equipment	Total
Rectangular pad type foundations For pumps, compressors, boilers and similar equipment mounted at grade. Form costs assume nails, stakes and form oil costing \$.50 per square foot and 1.1 SF of 3/4" plyform plus 2.2 BF of lumber per square foot of contact surface. Costs shown are per cubic yard (CY) of concrete within the foundation.						
Lay out foundation from known point on site, set stakes and mark for excavation, with 1 CY per CY of concrete	C8@.147	CY	.09	7.00	—	7.09
Excavation with utility backhoe, at 28 CY per hour, with 1.5 CY per CY of concrete	S1@.108	CY	—	5.37	4.48	9.85
Formwork, material (3 uses) and labor at .150 manhours per SF with 15 SF per CY of concrete	F5@2.25	CY	42.20	110.00	—	152.20
Place .006" polyethylene vapor barrier with 90 SF per CY of concrete	C8@.180	CY	8.59	8.57	—	17.16
Reinforcing bars, Grade 60, set and tied, material and labor .006 manhours per lb with 25 lb per CY of concrete	RB@.150	CY	25.60	9.86	—	35.46
Anchor bolts, sleeves, embedded steel, material and labor at .040 manhours per lb with 5 lb per CY of concrete	C8@.200	CY	10.00	9.52	—	19.52
Ready-mix concrete, 3,000 PSI mix after allowance for 10% waste with 1 CY per CY of concrete	C8@.385	CY	146.00	18.30	—	164.30
Concrete test cylinders including test reports, with 5 per 100 CY of concrete	—	CY	1.25	—	—	1.25
Finish, sack and patch concrete, material and labor at .010 manhours per SF with 15 SF per CY of concrete	P8@.150	CY	1.20	7.01	—	8.21
Backfill around foundation with utility backhoe at 40 CY per hour, with .5 CY per CY of concrete	S1@.025	CY	—	1.24	.57	1.81
Dispose of excess soil on site with utility backhoe at 80 CY per hour with 1 CY per CY of concrete	S1@.025	CY	—	1.24	.57	1.81
Rectangular pad type foundation						
Total cost per CY of concrete	—@3.62	CY	234.93	178.11	5.62	418.66

Rectangular pad and stem wall type foundations For horizontal cylindrical or shell and tube heat exchangers mounted above grade. Form costs assume nails, stakes and form oil costing \$.50 per square foot and 1.1 SF of 3/4" plyform plus 4.5 BF of lumber per square foot of contact surface. Costs shown are per cubic yard (CY) of concrete within the foundations.

Lay out foundation from known point on site, set stakes and mark for excavation, with 1 CY per CY of concrete	C8@.147	CY	.07	7.00	—	7.07
Excavation with utility backhoe, at \$28 per hour, with 1 CY per CY of concrete	S1@.072	CY	—	3.58	1.63	5.21
Formwork, material (3 uses) per SF and labor at .200 manhours per SF with 60 SF per CY of concrete	F5@12.0	CY	283.00	585.00	—	868.00
Place .006" polyethylene vapor barrier with 90 SF per CY of concrete	C8@.180	CY	8.59	8.57	—	17.16
Reinforcing bars, Grade 60, set and tied, material per lb and labor at .006 manhours per lb with 45 lb per CY of concrete	RB@.270	CY	46.20	17.80	—	64.00
Anchor bolts, sleeves, embedded steel, material and labor at .040 manhours per lb with 5 lb per CY of concrete	C8@.200	CY	9.69	9.52	—	19.21
Ready-mix concrete, 3,000 PSI mix, after 10% waste allowance with 1 CY per CY	C8@.385	CY	146.00	18.30	—	164.30
Concrete test cylinders including test reports, with 5 per 100 CY	—	CY	1.25	—	—	1.25
Finish, sack and patch concrete, material per SF and labor at .010 manhours per SF with 60 SF per CY of concrete	P8@.600	CY	4.46	28.10	—	32.56

03 Concrete

	Craft@Hrs	Unit	Material	Labor	Equipment	Total
Backfill around foundation with utility backhoe, at 40 CY per hour, with .5 CY per CY of concrete	S1@.025	CY	—	1.24	.57	1.81
Dispose of excess soil on site with utility backhoe, at 80 CY per hour, with .5 CY per CY of concrete	S1@.025	CY	—	1.24	.57	1.81
Rectangular pad and stem wall type foundation						
Total cost per CY of concrete	—@13.9	CY	499.26	680.35	2.77	1,182.38

Square pad and pedestal type foundations For vertical cylindrical tanks not over 3' in diameter.

Form costs assume nails, stakes and form oil costing \$.50 per square foot and 1.1 SF of 3/4" plyform plus 3 BF of lumber per square foot of contact surface. Costs shown are per cubic yard (CY) of concrete within the foundations.

Lay out foundation from known point on site, set stakes and mark for excavation,

with 1 CY per CY of concrete	C8@.147	CY	.09	7.00	—	7.09
Excavation with utility backhoe, at 28 CY per hour, with 1 CY per CY of concrete	S1@.072	CY	—	3.58	1.63	5.21
Formwork, material and labor at .192 manhours per SF with 13 SF per CY of concrete	F5@2.50	CY	47.90	122.00	—	169.90
Place .006" polyethylene vapor barrier with 90 SF per CY of concrete	C8@.180	CY	8.59	8.57	—	17.16
Reinforcing bars, Grade 60, set and tied, material and labor at .006 manhours per lb with 20 lb per CY of concrete	RB@.120	CY	46.20	7.89	—	54.09
Anchor bolts, sleeves, embedded steel, material and labor at .040 manhours per lb with 2 lb per CY of concrete	C8@.080	CY	4.00	3.81	—	7.81
Ready-mix concrete, 3,000 PSI mix, after 10% waste allowance with 1 CY per CY	C8@.385	CY	146.00	18.30	—	164.30
Concrete test cylinders including test reports, with 5 per 100 CY	—	CY	1.25	—	—	1.25
Finish, sack and patch concrete, material per SF and labor at .010 manhours per SF with 60 SF per CY of concrete	P8@.600	CY	5.67	28.10	—	33.77
Backfill around foundation with utility backhoe, at 40 CY per hour, with .5 CY per CY of concrete	S1@.025	CY	—	1.24	.57	1.81
Dispose of excess soil on site with utility backhoe, at 80 CY per hour, with .5 CY per CY of concrete	S1@.025	CY	—	1.24	.57	1.81
Square pad and pedestal type foundation						
Total cost per CY of concrete	—@4.13	CY	259.70	201.73	2.77	464.20

Octagonal pad and pedestal type foundations For vertical cylindrical tanks over 3' in diameter. Form costs

assume nails, stakes and form oil costing \$.50 per square foot and 1.1 SF of 3/4" plyform plus 4.5 BF of lumber per square foot of contact surface. Costs shown are per cubic yard (CY) of concrete within the foundation.

Lay out foundation from known point on site, set stakes and mark for excavation,

with 1 CY per CY of concrete	C8@.147	CY	.09	7.00	—	7.09
Excavation with utility backhoe, at \$28 CY per hour, with 1 CY per CY of concrete	S1@.072	CY	—	3.58	1.63	5.21
Formwork, material SF and labor at .250 manhours per SF with 10 SF per CY of concrete	F5@2.50	CY	46.20	122.00	—	168.20
Place .006" polyethylene vapor barrier with 90 SF per CY of concrete	C8@.180	CY	8.59	8.57	—	17.16
Reinforcing bars, Grade 60, set and tied, material and labor at .006 manhours per lb with 20 lb per CY of concrete	RB@.120	CY	20.50	7.89	—	28.39
Anchor bolts, sleeves, embedded steel, material and labor at .040 manhours per lb with 2 lb per CY of concrete	C8@.080	CY	4.00	3.81	—	7.81
Ready-mix concrete, 3,000 PSI mix, after 10% waste allowance with 1 CY per CY of concrete	C8@.385	CY	146.00	18.30	—	164.30

03 Concrete

	Craft@Hrs	Unit	Material	Labor	Equipment	Total
Concrete test cylinders including test reports, with 5 per 100 CY of concrete	—	CY	1.25	—	—	1.25
Finish, sack and patch concrete, material and labor at .010 manhours per SF with 60 SF per CY of concrete	P8@.600	CY	4.63	28.10	—	32.73
Backfill around foundation with utility backhoe, at 40 CY per hour, with .5 CY per CY of concrete	S1@.025	CY	—	1.24	.57	1.81
Dispose of excess soil on site with utility backhoe, at 80 CY per hour, with .5 CY per CY of concrete	S1@.025	CY	—	1.24	.57	1.81
Octagonal pad and pedestal type foundation						
Total cost per CY of concrete	—@4.13	CY	231.26	201.73	2.77	435.76

	Craft@Hrs	Unit	Material	Labor	Equipment	Total
Cementitious Decks, Subcontract Typical costs including the subcontractor's overhead and profit.						
Insulating concrete deck, poured on existing substrate, 1-1/2" thick						
Under 3,000 SF	—	SF	—	—	—	2.99
Over 3,000 SF to 10,000 SF	—	SF	—	—	—	2.60
Over 10,000 SF	—	SF	—	—	—	2.17
Poured on existing metal deck, 2-5/8" thick, lightweight						
Concrete fill, trowel finish	—	SF	—	—	—	3.51
Gypsum decking, poured over form board, screed and float	—	SF	—	—	—	3.18
Vermiculite, screed and float, field mixed	—	SF	—	—	—	2.61
Exterior concrete deck for walking service, troweled						
Lightweight, 2-5/8", 110 lbs per CF	—	SF	—	—	—	4.54
Add for 4,000 PSI mix	—	SF	—	—	—	.72
Add for 5,000 PSI mix	—	SF	—	—	—	.54
Pool deck at pool side, 1/8" to 3/16" thick, colors, finished	—	SF	—	—	—	4.09
Fiber deck, tongue and groove, cementitious planks, complete						
2" thick	—	SF	—	—	—	3.45
2-1/2" thick	—	SF	—	—	—	4.19
3" thick	—	SF	—	—	—	4.59

Concrete Surfacing, Subcontract Load-bearing, architectural, three-part, acrylic polymer cementitious resurfacing system. 6,000 PSI compressive strength. Applied over existing concrete, aggregate, masonry, steel, asphalt, foam or wood surfaces. Installed on surfaces that do not require crack repair, brick or tile patterns or the removal of heavy grease contaminants. Includes stain sealer and colored texture coat. Based on a typical 1,000 square foot project. www.concreteconstruction.net

Applied over new surface	—	SF	—	—	—	1.21
Applied over old concrete, includes cleaning	—	SF	—	—	—	2.19
Applied over pool interior, includes cleaning	—	SF	—	—	—	2.62
Applied over vertical surface	—	SF	—	—	—	3.01

Surface Imprinted Concrete Paving, Subcontract Patterned and colored to simulate slate, granite, limestone, sandstone, wood or cobblestone. 3 to 4 inch depth. Costs include imprinting and texturing, concrete placement and finish, color hardener, release agent and sealer application. Add the cost of grading, forms and form stripping. www.bomanite.com

Regular grade	—	SF	—	—	—	24.50
Heavy grade (for heavy road traffic and freeze areas)	—	SF	—	—	—	30.10

Troweled-on Cementitious Coating, Subcontract For direct use on interior flooring, accent areas or walls. Bonds to concrete, wood, metal, plastic or asphalt.

Cementitious coating	—	SF	—	—	—	18.10
----------------------	---	----	---	---	---	-------

03 Concrete

	Unit	Brick or 200'	Concrete 1000'	Concrete 1000'
Wall Sawing, Subcontract Using an electric, hydraulic or air saw. Per LF of cut including overcuts at each corner equal to the depth of the cut. Costs shown assume electric power is available. Minimum cost will be \$400.				
To 4" depth	LF	13.70	19.80	21.80
To 5" depth	LF	17.40	21.40	25.40
To 6" depth	LF	19.00	23.00	28.70
To 7" depth	LF	23.90	28.20	33.00
To 8" depth	LF	29.00	33.00	39.60
To 10" depth	LF	36.30	40.80	47.20
To 12" depth	LF	44.50	49.20	56.10
To 14" depth	LF	54.50	59.40	65.20
To 16" depth	LF	66.70	67.70	74.40
To 18" depth	LF	77.40	79.50	88.90

Concrete Core Drilling, Subcontract Using an electric, hydraulic or air drill. Costs shown are per LF of depth for diameter shown. Prices are based on one mat reinforcing with 3/8" to 5/8" bars and include cleanup. Difficult drill setups are higher. Prices assume availability of 110 volt electricity. Figure travel time at \$110 per hour. Minimum cost will be \$250.

	Craft@Hrs	Unit	Material	Labor	Total
1" or 1-1/2" diameter	—	LF	—	—	60.50
2" or 2-1/2" diameter	—	LF	—	—	62.50
3" or 3-1/2" diameter	—	LF	—	—	75.30
4" or 5" diameter	—	LF	—	—	91.70
6" or 8" diameter	—	LF	—	—	126.00
10" diameter	—	LF	—	—	174.00
12" diameter	—	LF	—	—	282.00
14" diameter	—	LF	—	—	324.00
16" diameter	—	LF	—	—	367.00
18" diameter	—	LF	—	—	409.00
20" diameter	—	LF	—	—	453.00
24" diameter	—	LF	—	—	540.00
30" diameter	—	LF	—	—	666.00
36" diameter	—	LF	—	—	798.00
Hourly rate, 2 hour minimum	—	Hr	—	—	133.00

Concrete Slab Sawing, Subcontract Using a gasoline powered saw. Costs per linear foot for cured concrete assuming a level surface with good access and saw cut lines laid out and pre-marked by others. Costs include local travel time. Minimum cost will be \$250. Electric powered slab sawing will be approximately 40% higher for the same depth.

	Unit	Under 200'	200'- 1000'	Over 1000'
1" deep	LF	.73	.64	.54
1-1/2" deep	LF	1.09	.99	.82
2" deep	LF	1.42	1.26	1.09
2-1/2" deep	LF	1.81	1.62	1.34
3" deep	LF	2.16	1.89	1.62
3-1/2" deep	LF	2.51	2.25	1.89
4" deep	LF	2.86	2.51	2.16
5" deep	LF	3.87	3.15	2.69
6" deep	LF	4.31	3.79	3.24
7" deep	LF	5.21	4.47	3.87
8" deep	LF	5.93	5.21	4.47
9" deep	LF	6.74	5.93	5.14
10" deep	LF	7.63	6.74	5.85
11" deep	LF	8.52	7.53	6.54
12" deep	LF	9.44	8.36	7.28

03 Concrete

Green concrete (2 days old) sawing will usually cost 15 to 20% less. Work done on an hourly basis will cost \$125 per hour for slabs up to 4" thick and \$135 per hour for 5" or 6" thick slabs. A two hour minimum charge will apply on work done on an hourly basis.

Asphalt Sawing, Subcontract Using a gasoline powered saw. Minimum cost will be \$200. Cost per linear foot of green or cured asphalt, assuming level surface with good access and saw cut lines laid out and pre-marked by others. Costs include local travel time. Work done on an hourly basis will cost \$115 per hour for asphalt up to 4" thick and \$125 per hour for 5" or 6" thick asphalt. A two hour minimum charge will apply on work done on an hourly basis.

Depth	Unit	Under 450'	450'- 1000'	Over 1000'
1" or 1-1/2" deep	LF	.45	.36	.27
2" deep	LF	.73	.54	.45
2-1/2" deep	LF	.88	.73	.54
3" deep	LF	1.09	.82	.64
3-1/2" deep	LF	1.26	.99	.73
4" deep	LF	1.42	1.09	.82
5" deep	LF	1.81	1.34	.99
6" deep	LF	2.16	1.62	1.18

04 Masonry

Cleaning and Pointing Masonry These costs assume the masonry surface is in fair to good condition with no unusual damage. Add the cost of protecting adjacent surfaces such as trim or the base of the wall and the cost of scaffolding, if required. Labor required to presoak or saturate the area cleaned is included in the labor cost. Work more than 12' above floor level will increase costs.

	Craft@Hrs	Unit	Material	Labor	Total
Brushing (hand cleaning) masonry includes the cost of detergent or chemical solution.					
Light cleanup (100 SF per manhour)	M1@.010	SF	.04	.48	.52
Medium scrub (75 SF per manhour)	M1@.013	SF	.05	.63	.68
Heavy (50 SF per manhour)	M1@.020	SF	.07	.96	1.03

	Craft@Hrs	Unit	Material	Labor	Equipment	Total
Water blasting masonry, using rented 400 to 700 PSI power washer with 3 to 8 gallon per minute flow rate, includes blaster rental at \$65 per day						
Smooth face (250 SF per manhour)	M1@.004	SF	—	.19	.04	.23
Rough face (200 SF per manhour)	M1@.005	SF	—	.24	.05	.29
Sandblasting masonry, using 150 PSI compressor (with accessories and sand) at \$130.00 per day						
Smooth face (50 SF per manhour)	M1@.020	SF	.50	.96	.25	1.71
Rough face (40 SF per manhour)	M1@.025	SF	.57	1.20	.51	2.28
Steam cleaning masonry, using rented steam cleaning rig (with accessories) at \$112.00 per day						
Smooth face (75 SF per manhour)	M1@.013	SF	—	.63	.14	.77
Rough face (55 SF per manhour)	M1@.018	SF	—	.87	.19	1.06

	Craft@Hrs	Unit	Material	Labor	Total
Repointing brick, cut out joint, mask (blend-in), and regrout (tuck pointing)					
30 SF per manhour	M1@.033	SF	.08	1.59	1.67
Add for masking adjacent surfaces	—	%	—	5.0	—
Add for difficult stain removal	—	%	50.0	50.0	—
Add for working from scaffold	—	%	—	20.0	—

04 Masonry

	Craft@Hrs	Unit	Material	Labor	Total
Masonry Cleaning Costs to clean masonry surfaces using commercial cleaning agents, add for pressure washing and scaffolding equipment.					
Typical cleaning of surfaces					
Granite, sandstone, terra cotta, brick	CL@.015	SF	.32	.62	.94
Cleaning surfaces of heavily carbonated					
Limestone or cast stone	CL@.045	SF	.42	1.87	2.29
Typical wash with acid and rinse	CL@.004	SF	.48	.17	.65
Masonry Reinforcing and Flashing Reinforcing bars for concrete block, ASTM A615 grade 60 bars, cost per linear foot including 10% overlap and waste.					
#3 bars (3/8", 5,319 LF per ton), horizontal	M1@.005	LF	.43	.24	.67
#3 bars placed vertically	M1@.006	LF	.43	.29	.72
#3 galvanized bars, horizontal	M1@.005	LF	.86	.24	1.10
#3 galvanized bars placed vertically	M1@.006	LF	.86	.29	1.15
#4 bars (1/2", 2,994 LF per ton), horizontal	M1@.008	LF	.64	.39	1.03
#4 bars placed vertically	M1@.010	LF	.64	.48	1.12
#4 galvanized bars, horizontal	M1@.008	LF	1.07	.39	1.46
#4 galvanized bars placed vertically	M1@.010	LF	1.07	.48	1.55
#5 bars (5/8", 1,918 LF per ton), horizontal	M1@.009	LF	.86	.43	1.29
#5 bars placed vertically	M1@.012	LF	.86	.58	1.44
#5 galvanized bars, horizontal	M1@.009	LF	1.42	.43	1.85
#5 galvanized bars placed vertically	M1@.012	LF	1.42	.58	2.00
#6 bars (3/4", 1,332 LF per ton), horizontal	M1@.010	LF	1.19	.48	1.67
#6 bars placed vertically	M1@.013	LF	1.19	.63	1.82
#6 galvanized bars, horizontal	M1@.014	LF	1.73	.67	2.40
#6 galvanized bars placed vertically	M1@.014	LF	1.73	.67	2.40
Wall ties					
Rectangular, galvanized	M1@.005	Ea	.70	.24	.94
Rectangular, copper coated	M1@.005	Ea	.84	.24	1.08
Cavity "Z"-type, galvanized	M1@.005	Ea	.67	.24	.91
Cavity "Z"-type, copper coated	M1@.005	Ea	.75	.24	.99
Masonry anchors, steel, including bolts					
3/16" x 18" long	M1@.173	Ea	5.22	8.34	13.56
3/16" x 24" long	M1@.192	Ea	6.54	9.25	15.79
1/4" x 18" long	M1@.216	Ea	6.71	10.40	17.11
1/4" x 24" long	M1@.249	Ea	8.19	12.00	20.19
Wall reinforcing					
Truss-type, plain					
4" wall	M1@.002	LF	.45	.10	.55
6" wall	M1@.002	LF	.54	.10	.64
8" wall	M1@.003	LF	.57	.14	.71
10" wall	M1@.003	LF	.63	.14	.77
12" wall	M1@.004	LF	.67	.19	.86
Truss-type, galvanized					
4" wall	M1@.002	LF	.55	.10	.65
6" wall	M1@.002	LF	.60	.10	.70
8" wall	M1@.003	LF	.73	.14	.87
10" wall	M1@.003	LF	.78	.14	.92
12" wall	M1@.004	LF	.87	.19	1.06
Ladder-type, galvanized, Class 3					
2" wide, for 4" wall	M1@.003	LF	.31	.14	.45
4" wide	M1@.003	LF	.62	.14	.76
6" wide	M1@.003	LF	.62	.14	.76
8" wide	M1@.003	LF	.68	.14	.82

04 Masonry

	Craft@Hrs	Unit	Material	Labor	Total
Control joints					
Cross-shaped PVC	M1@.024	LF	2.48	1.16	3.64
8" wide PVC	M1@.047	LF	3.31	2.26	5.57
Closed cell 1/2" joint filler	M1@.012	LF	.48	.58	1.06
Closed cell 3/4" joint filler	M1@.012	LF	.81	.58	1.39
Through-the-wall flashing					
5 ounce copper	M1@.023	SF	3.78	1.11	4.89
.030" elastomeric sheeting	M1@.038	SF	.72	1.83	2.55
Expansion Shields Masonry anchors set in block or concrete including drilling. With nut and washer. Length indicates drilled depth.					
One wedge anchors, 1/4" diameter					
1-3/4" long	CL@.079	Ea	.95	3.29	4.24
2-1/4" long	CL@.114	Ea	1.14	4.75	5.89
3-1/4" long	CL@.171	Ea	1.50	7.12	8.62
One wedge anchors, 1/2" diameter					
4-1/4" long	CL@.227	Ea	2.38	9.46	11.84
5-1/2" long	CL@.295	Ea	3.17	12.30	15.47
7" long	CL@.409	Ea	3.87	17.00	20.87
One wedge anchors, 3/4" diameter					
5-1/2" long	CL@.286	Ea	6.50	11.90	18.40
8-1/2" long	CL@.497	Ea	9.28	20.70	29.98
10" long	CL@.692	Ea	10.90	28.80	39.70
One wedge anchors, 1" diameter					
6" long	CL@.295	Ea	15.90	12.30	28.20
9" long	CL@.515	Ea	19.70	21.50	41.20
12" long	CL@.689	Ea	22.90	28.70	51.60
Flush self-drilling anchors					
1/4" x 1-1/4"	CL@.094	Ea	.95	3.92	4.87
5/16" x 1-1/4"	CL@.108	Ea	1.14	4.50	5.64
3/8" x 1-1/2"	CL@.121	Ea	1.50	5.04	6.54
1/2" x 1-1/2"	CL@.159	Ea	2.24	6.62	8.86
5/8" x 2-3/8"	CL@.205	Ea	3.54	8.54	12.08
3/4" x 2-3/8"	CL@.257	Ea	5.75	10.70	16.45
Brick Wall Assemblies Typical costs for smooth red clay brick walls, laid in running bond with 3/8" concave joints. These costs include the bricks, mortar for bricks and cavities, typical ladder type reinforcing, wall ties and normal waste. Foundations are not included. Wall thickness shown is the nominal size based on using the type bricks described. "Wythe" means the quantity of bricks in the thickness of the wall. Costs shown are per square foot (SF) of wall measured on one face. Deduct for openings over 10 SF in size. The names and dimensions of bricks can be expected to vary, depending on the manufacturer. For more detailed coverage of brick wall assemblies, see <i>National Concrete & Masonry Estimator</i> , https://craftsman-book.com/national-estimator-cloud .					
Standard bricks, 3-3/4" wide x 2-1/4" high x 8" long					
4" thick wall, single wythe, veneer facing	M1@.211	SF	6.55	10.20	16.75
8" thick wall, double wythe, cavity filled	M1@.464	SF	12.90	22.40	35.30
12" thick wall, triple wythe, cavity filled	M1@.696	SF	19.30	33.50	52.80
Modular bricks, 3" wide x 3-1/2" x 11-1/2" long					
3-1/2" thick wall, single wythe, veneer facing	M1@.156	SF	5.29	7.52	12.81
7-1/2" thick wall, double wythe, cavity filled	M1@.343	SF	10.40	16.50	26.90
11-1/2" thick wall, triple wythe, cavity filled	M1@.515	SF	15.50	24.80	40.30
Colonial bricks, 3" wide x 3-1/2" x 10" long					
3-1/2" thick wall, single wythe, veneer facing	M1@.177	SF	4.55	8.53	13.08
7-1/2" thick wall, double wythe, cavity filled	M1@.389	SF	8.91	18.70	27.61
11-1/2" thick wall, triple wythe, cavity filled	M1@.584	SF	13.30	28.10	41.40

04 Masonry

	Craft@Hrs	Unit	Material	Labor	Total
Add to any brick wall assembly above for:					
American bond or stacked bond	—	%	5.0	10.0	—
Basketweave bond or soldier bond	—	%	10.0	10.0	—
Flemish bond	—	%	10.0	15.0	—
Herringbone pattern	—	%	15.0	15.0	—
Institutional inspection	—	%	—	20.0	—
Short runs or cut-up work	—	%	5.0	15.0	—
Fireplaces Common brick, including the chimney foundation, damper, flue lining and stack to 15'					
30" box, brick to 5', large quantity	M1@30.3	Ea	1,740.00	1,460.00	3,200.00
36" box, brick to 5', custom	M1@33.7	Ea	2,110.00	1,620.00	3,730.00
42" box, brick to 8', custom	M1@48.1	Ea	2,460.00	2,320.00	4,780.00
48" box, brick to 8', custom	M1@53.1	Ea	2,840.00	2,560.00	5,400.00
Flue lining, 1' lengths					
8-1/2" round	M1@.148	LF	7.52	7.13	14.65
10" x 17" oval	M1@.206	LF	12.80	9.93	22.73
13" x 13" square	M1@.193	LF	13.40	9.30	22.70
Prefabricated cast concrete					
30" box and 15' chimney	M1@5.43	Ea	1,840.00	262.00	2,102.00
Face brick, mantle to ceiling	M1@.451	SF	5.43	21.70	27.13
Clay Backing Tile Load bearing, 12" x 12"					
4" thick	M1@.066	SF	5.25	3.18	8.43
6" thick	M1@.079	SF	5.92	3.81	9.73
8" thick	M1@.091	SF	6.96	4.38	11.34
Deduct for non-load bearing tile	—	%	-8.0	-10.0	—
Structural Glazed Tile Heavy-duty, fire-safe, structural glazed facing tile for interior surfaces. No foundations or reinforcing included.					
Glazed one side, all colors, 5-1/3" x 12"					
2" thick	M1@.125	SF	5.94	6.02	11.96
4" thick	M1@.136	SF	7.16	6.55	13.71
6" thick	M1@.141	SF	10.60	6.79	17.39
8" thick	M1@.172	SF	13.30	8.29	21.59
Glazed one side, all colors, 8" x 16" block					
2" thick	M1@.072	SF	6.67	3.47	10.14
4" thick	M1@.072	SF	7.16	3.47	10.63
6" thick	M1@.079	SF	9.90	3.81	13.71
8" thick	M1@.085	SF	11.50	4.10	15.60
Acoustical glazed facing tile, with small holes on a smooth ceramic glazed facing, and one mineral fiberglass sound batt located in the hollow core behind perforated face					
8" x 8" face size unit, 4" thick	M1@.136	SF	11.70	6.55	18.25
8" x 16" face size unit, 4" thick	M1@.141	SF	10.50	6.79	17.29
Reinforced glazed security tile, with vertical cores and knockouts for horizontal reinforcing, 8" x 16" block					
4" thick	M1@.092	SF	9.16	4.43	13.59
6" thick	M1@.095	SF	11.80	4.58	16.38
8" thick	M1@.101	SF	14.20	4.87	19.07
Add to 8" security tile for horizontal and vertical reinforcing and grout cores to meet high security standards					
	M1@.047	SF	3.90	2.24	5.98
Add for glazed 2 sides	—	%	55.0	10.0	—
Base, glazed 1 side	M1@.190	LF	8.86	9.15	18.01
Cap, glazed 2 sides	M1@.193	LF	14.80	9.30	24.10
Deduct for large areas	—	%	-5.0	-5.0	—
Add for institutional inspection	—	%	—	10.0	—

04 Masonry

Craft@Hrs Unit Material Labor Total

Chemical-Resistant Brick or Tile, Subcontract (also known as acid-proof brick). Typical prices for chemical-resistant brick or tile meeting ASTM C-279, types I, II, and III requirements. Installed with 1/8" thick bed and mortar joints over a membrane of either elastomeric bonded to the floors or walls, sheet membrane with a special seam treatment, squeegee hot-applied asphalt, cold-applied adhesive troweled on, or special spray-applied material. The setting bed and joint materials can be either 100% carbon-filled furan or phenolic, sodium or potassium silicates, silica-filled epoxy, polyester, vinyl ester or other special mortars. Expansion joints are required in floor construction, particularly where construction joints exist in the concrete. Additional expansion joints may be required, depending on the service conditions to which the floor will be subjected. Brick or tile will be either 3-3/4" x 8" face, 1-1/8" thick (splits); 3-3/4" x 8" face, 2-1/4" thick (singles); or 4" x 8" face, 1-3/8" thick (pavers). Costs are based on a 2,000 SF job. For smaller projects, increase the cost 5% for each 500 SF or portion of 500 SF less than 2,000 SF. For scheduling purposes estimate that a crew of 4 can install 75 to 100 SF of membrane and brick in an 8-hour day. These costs assume that the membrane is laid on a suitable surface prepared by others and include the subcontractor's overhead and profit.

Typical installed costs for chemical-resistant brick or tile (acid-proof brick), installed

Less complex jobs	—	SF	—	—	35.40
More complex jobs	—	SF	—	—	42.90
Minimum job cost	—	LS	—	—	23,200.00

Craft@Hrs Unit Material Labor Equipment Total

Concrete Block Retaining Walls Includes mortar, 8" x 8" x 16" regular block, U-block, inspection block (for walls six courses high or higher) grout, cavity caps and No. 5 reinforcing steel. Equipment is a trailer-mounted 15 CY per hour grout pump, locally rented. Add the cost of wall foundations from the section that follows. For more detailed coverage of concrete block retaining walls, see *National Concrete & Masonry Estimator*, <https://craftsman-book.com/national-estimator-cloud>.

Retaining wall with one lintel block course and grouted and reinforced vertical cells at 16" O.C.

3' - 4" high wall	M1@.504	LF	17.70	24.30	.34	42.34
4' - 0" high wall	M1@.576	LF	21.30	27.80	.40	49.50
4' - 8" high wall	M1@.648	LF	24.30	31.20	.45	55.95
5' - 4" high wall	M1@.720	LF	27.30	34.70	.51	62.51
6' - 0" high wall	M1@.793	LF	30.30	38.20	.57	69.07
6' - 8" high wall	M1@.864	LF	33.30	41.60	.63	75.53
7' - 4" high wall	M1@.936	LF	36.30	45.10	.69	82.09
8' - 0" high wall	M1@1.01	LF	39.30	48.70	.75	88.75

Retaining wall with one lintel block course and grouted and reinforced vertical cells at 32" O.C.

3' - 4" high wall	M1@.454	LF	15.10	21.90	.22	37.22
4' - 0" high wall	M1@.526	LF	17.80	25.30	.25	43.35
4' - 8" high wall	M1@.598	LF	20.20	28.80	.28	49.28
5' - 4" high wall	M1@.670	LF	22.60	32.30	.31	55.21
6' - 0" high wall	M1@.743	LF	25.10	35.80	.34	61.24
6' - 8" high wall	M1@.814	LF	27.50	39.20	.37	67.07
7' - 4" high wall	M1@.886	LF	30.00	42.70	.40	73.10
8' - 0" high wall	M1@.958	LF	32.40	46.20	.43	79.03

Retaining wall with one lintel block course and grouted and reinforced vertical cells at 48" O.C.

3' - 4" high wall	M1@.436	LF	14.20	21.00	.18	35.38
4' - 0" high wall	M1@.508	LF	16.60	24.50	.20	41.30
4' - 8" high wall	M1@.580	LF	18.80	27.90	.22	46.92
5' - 4" high wall	M1@.652	LF	21.10	31.40	.24	52.74
6' - 0" high wall	M1@.725	LF	23.40	34.90	.26	58.56
6' - 8" high wall	M1@.797	LF	25.60	38.40	.28	64.28
7' - 4" high wall	M1@.869	LF	27.80	41.90	.30	70.00
8' - 0" high wall	M1@.941	LF	30.20	45.30	.32	75.82

04 Masonry

	Craft@Hrs	Unit	Material	Labor	Equipment	Total
Retaining wall with two lintel block courses and grouted and reinforced vertical cells at 16" O.C.						
3' - 4" high wall	M1@.546	LF	19.70	26.30	.39	46.39
4' - 0" high wall	M1@.617	LF	23.30	29.70	.44	53.44
4' - 8" high wall	M1@.689	LF	26.20	33.20	.50	59.90
5' - 4" high wall	M1@.761	LF	29.20	36.70	.56	66.46
6' - 0" high wall	M1@.833	LF	32.30	40.10	.62	73.02
6' - 8" high wall	M1@.906	LF	35.30	43.70	.68	79.68
7' - 4" high wall	M1@.978	LF	38.20	47.10	.73	86.03
8' - 0" high wall	M1@1.05	LF	41.30	50.60	.79	92.69
Retaining wall with two lintel block courses and grouted and reinforced vertical cells at 32" O.C.						
3' - 4" high wall	M1@.495	LF	17.50	23.80	.30	41.60
4' - 0" high wall	M1@.567	LF	20.20	27.30	.33	47.83
4' - 8" high wall	M1@.639	LF	22.60	30.80	.36	53.76
5' - 4" high wall	M1@.711	LF	25.00	34.30	.39	59.69
6' - 0" high wall	M1@.783	LF	27.50	37.70	.42	65.62
6' - 8" high wall	M1@.856	LF	30.00	41.20	.44	71.64
7' - 4" high wall	M1@.928	LF	32.40	44.70	.47	77.57
8' - 0" high wall	M1@1.00	LF	34.90	48.20	.50	83.60
Retaining wall with two lintel block courses and grouted and reinforced vertical cells at 48" O.C.						
3' - 4" high wall	M1@.478	LF	16.70	23.00	.27	39.97
4' - 0" high wall	M1@.550	LF	19.20	26.50	.29	45.99
4' - 8" high wall	M1@.621	LF	21.40	29.90	.31	51.61
5' - 4" high wall	M1@.693	LF	23.60	33.40	.33	57.33
6' - 0" high wall	M1@.766	LF	25.90	36.90	.35	63.15
6' - 8" high wall	M1@.839	LF	28.20	40.40	.37	68.97
7' - 4" high wall	M1@.910	LF	30.40	43.80	.39	74.59
8' - 0" high wall	M1@.982	LF	32.70	47.30	.40	80.40
Retaining wall with three lintel block courses and grouted and reinforced vertical cells at 16" O.C.						
3' - 4" high wall	M1@.587	LF	21.70	28.30	.43	50.43
4' - 0" high wall	M1@.660	LF	25.20	31.80	.49	57.49
4' - 8" high wall	M1@.732	LF	28.20	35.30	.55	64.05
5' - 4" high wall	M1@.804	LF	31.20	38.70	.61	70.51
6' - 0" high wall	M1@.876	LF	34.20	42.20	.67	77.07
6' - 8" high wall	M1@.948	LF	37.20	45.70	.72	83.62
7' - 4" high wall	M1@1.02	LF	40.20	49.10	.78	90.08
8' - 0" high wall	M1@1.09	LF	43.20	52.50	.84	96.54
Retaining wall with three lintel block courses and grouted and reinforced vertical cells at 32" O.C.						
3' - 4" high wall	M1@.537	LF	19.90	25.90	.38	46.18
4' - 0" high wall	M1@.610	LF	22.60	29.40	.40	52.40
4' - 8" high wall	M1@.682	LF	25.00	32.90	.43	58.33
5' - 4" high wall	M1@.754	LF	27.50	36.30	.46	64.26
6' - 0" high wall	M1@.826	LF	29.90	39.80	.49	70.19
6' - 8" high wall	M1@.898	LF	32.40	43.30	.52	76.22
7' - 4" high wall	M1@.971	LF	34.80	46.80	.55	82.15
8' - 0" high wall	M1@1.04	LF	37.30	50.10	.58	87.98
Retaining wall with three lintel block course and grouted and reinforced vertical cells at 48" O.C.						
3' - 4" high wall	M1@.520	LF	19.30	25.10	.36	44.76
4' - 0" high wall	M1@.593	LF	21.70	28.60	.38	50.68
4' - 8" high wall	M1@.664	LF	24.00	32.00	.40	56.40
5' - 4" high wall	M1@.736	LF	26.20	35.50	.41	62.11
6' - 0" high wall	M1@.808	LF	28.50	38.90	.43	67.83
6' - 8" high wall	M1@.880	LF	30.80	42.40	.45	73.65
7' - 4" high wall	M1@.953	LF	33.00	45.90	.47	79.37
8' - 0" high wall	M1@1.03	LF	35.30	49.60	.49	85.39

04 Masonry

	Craft@Hrs	Unit	Material	Labor	Total
Concrete Foundations for Retaining Walls Includes hand excavation in normal soil, backfilling, board or plywood forming as noted, grade 60 reinforcing steel and 3,000 P.S.I. concrete poured from the chute. Concrete waste when poured against earth is assumed to be 1" of concrete at the bottom of the footing and 2" along the walls. Concrete waste when poured against forms is assumed to be 1" at the bottom of the pad. When forms are used, estimate that excavation will be required 18" beyond the forms.					
36" wide x 12" deep foundation with 4 No. 5 bars, 2' deep					
Hand excavated, poured against earth					
Excavation	CL@.412	LF	—	17.20	17.20
Reinforcing steel	RB@.072	LF	4.14	4.73	8.87
Concrete	CL@.075	LF	17.30	3.12	20.42
Hand excavated, poured against forms					
Excavation	CL@.894	LF	—	37.20	37.20
Formwork	M2@.251	LF	2.88	11.50	14.38
Reinforcing steel	RB@.072	LF	4.14	4.73	8.87
Concrete	CL@.068	LF	16.40	2.83	19.23
36" wide x 12" deep with 4 No. 5 bars, 3' deep					
Hand excavated, poured against earth					
Excavation	CL@.635	LF	—	26.50	26.50
Reinforcing steel	RB@.072	LF	4.14	4.73	8.87
Concrete	CL@.075	LF	17.30	3.12	20.42
Hand excavated, poured against forms					
Excavation	CL@1.36	LF	—	56.70	56.70
Formwork	M2@.251	LF	2.88	11.50	14.38
Reinforcing steel	RB@.072	LF	4.14	4.73	8.87
Concrete	CL@.068	LF	16.40	2.83	19.23
36" wide x 12" deep with 6 No. 5 bars, 2' deep					
Hand excavated, poured against earth					
Excavation	CL@.412	LF	—	17.20	17.20
Reinforcing steel	RB@.108	LF	6.21	7.10	13.31
Concrete	CL@.075	LF	17.30	3.12	20.42
Hand excavated, poured against forms					
Excavation	CL@.894	LF	—	37.20	37.20
Formwork	M2@.251	LF	2.88	11.50	14.38
Reinforcing steel	RB@.108	LF	6.21	7.10	13.31
Concrete	CL@.068	LF	16.40	2.83	19.23
36" wide x 12" deep with 6 No. 5 bars, 3' deep					
Hand excavated, poured against earth					
Excavation	CL@.635	LF	—	26.50	26.50
Reinforcing steel	RB@.108	LF	6.21	7.10	13.31
Concrete	CL@.075	LF	17.30	3.12	20.42
Hand excavated, poured against forms					
Excavation	CL@1.36	LF	—	56.70	56.70
Formwork	M2@.251	LF	2.88	11.50	14.38
Reinforcing steel	RB@.108	LF	6.21	7.10	13.31
Concrete	CL@.068	LF	16.40	2.83	19.23
36" wide x 16" deep with 6 No. 5 bars, 2' deep, No. 4 transverse bars at 2' O.C.					
Hand excavated, poured against earth					
Excavation	CL@.400	LF	—	16.70	16.70
Reinforcing steel	RB@.108	LF	7.15	7.10	14.25
Concrete	CL@.096	LF	22.60	4.00	26.60

04 Masonry

	Craft@Hrs	Unit	Material	Labor	Total
Hand excavated, poured against forms					
Excavation	CL@.882	LF	—	36.70	36.70
Formwork	M2@.337	LF	3.27	15.40	18.67
Reinforcing steel	RB@.108	LF	7.15	7.10	14.25
Concrete	CL@.089	LF	21.40	3.71	25.11
36" wide x 16" deep with 6 No. 5 bars, 3' deep, No. 4 transverse bars at 2' O.C.					
Hand excavated, poured against earth					
Excavation	CL@.624	LF	—	26.00	26.00
Reinforcing steel	RB@.108	LF	7.15	7.10	14.25
Concrete	CL@.096	LF	22.60	4.00	26.60
Hand excavated, poured against forms					
Excavation	CL@1.35	LF	—	56.20	56.20
Formwork	M2@.337	LF	3.27	15.40	18.67
Reinforcing steel	RB@.108	LF	7.15	7.10	14.25
Concrete	CL@.089	LF	21.40	3.71	25.11

Concrete Block Wall Assemblies Typical costs for standard natural gray medium weight masonry block walls including blocks, mortar, typical reinforcing and normal waste. Foundations are not included. For more detailed coverage of concrete block masonry, see *National Concrete & Masonry Estimator*, <https://craftsman-book.com/national-estimator-cloud>.

Walls constructed with 8" x 16" blocks laid in running bond

4" thick wall	M1@.090	SF	3.25	4.34	7.59
6" thick wall	M1@.100	SF	4.00	4.82	8.82
8" thick wall	M1@.120	SF	4.77	5.78	10.55
12" thick wall	M1@.150	SF	6.70	7.23	13.93

Additional costs for concrete block wall assemblies

Grouting Concrete Block Wall Cores Typical costs for filling concrete block wall cores with pumped concrete and rodded. Costs shown are based on 2 cores per 16" block and include a 10% allowance for waste.

Using C476 grout, pumped	—	CY	169.00	—	169.00
--------------------------	---	----	--------	---	--------

Material pumped in place and rodded, all cores filled.

4" thick wall, (4.98 SF per CF)	M1@.020	SF	1.25	.96	2.21
6" thick wall, (4.56 SF per CF)	M1@.022	SF	1.37	1.06	2.43
8" thick wall, (3.79 SF per CF)	M1@.024	SF	1.65	1.16	2.81
10" thick wall, (3.08 SF per CF)	M1@.031	SF	2.03	1.49	3.52
12" thick wall, (2.46 SF per CF)	M1@.040	SF	2.54	1.93	4.47

Add for grouting cores at 16" intervals, material pumped in place and rodded.

4" thick wall, (8.42 SF per CF)	M1@.011	SF	.74	.53	1.27
6" thick wall, (7.73 SF per CF)	M1@.012	SF	.81	.58	1.39
8" thick wall, (6.53 SF per CF)	M1@.014	SF	.96	.67	1.63
10" thick wall, (5.19 SF per CF)	M1@.019	SF	1.20	.92	2.12
12" thick wall, (4.21 SF per CF)	M1@.023	SF	1.49	1.11	2.60

Add for grouting cores at 24" intervals, material pumped in place and rodded.

4" thick wall, (10.24 SF per CF)	M1@.008	SF	.61	.39	1.00
6" thick wall, (9.02 SF per CF)	M1@.009	SF	.69	.43	1.12
8" thick wall, (8.61 SF per CF)	M1@.011	SF	.73	.53	1.26
10" thick wall, (6.76 SF per CF)	M1@.014	SF	.92	.67	1.59
12" thick wall, (5.57 SF per CF)	M1@.017	SF	1.12	.82	1.94

Add for grouting cores at 32" intervals, material pumped in place and rodded.

4" thick wall, (11.66 SF per CF)	M1@.007	SF	.54	.34	.88
6" thick wall, (10.24 SF per CF)	M1@.008	SF	.61	.39	1.00
8" thick wall, (9.97 SF per CF)	M1@.010	SF	.63	.48	1.11
10" thick wall, (8.06 SF per CF)	M1@.013	SF	.78	.63	1.41
12" thick wall, (6.65 SF per CF)	M1@.014	SF	.94	.67	1.61

04 Masonry

	Craft@Hrs	Unit	Material	Labor	Total
Add for grouting cores per vertical linear foot (VLF) of core, material pumped in place and rodded.					
4" thick wall, (8.86 VLF per CF)	M1@.011	VLF	1.06	.53	1.59
6" thick wall, (8.11 VLF per CF)	M1@.017	VLF	1.16	.82	1.98
8" thick wall, (6.73 VLF per CF)	M1@.024	VLF	1.39	1.16	2.55
10" thick wall, (5.47 VLF per CF)	M1@.026	VLF	1.71	1.25	2.96
12" thick wall, (4.37 VLF per CF)	M1@.028	VLF	2.14	1.35	3.49
Add for 2" thick caps, natural gray concrete					
4" thick wall	M1@.027	LF	1.30	1.30	2.60
6" thick wall	M1@.038	LF	1.55	1.83	3.38
8" thick wall	M1@.046	LF	1.81	2.22	4.03
12" thick wall	M1@.065	LF	2.65	3.13	5.78
Add for detailed block, 3/8" score					
Single score, one side	—	SF	.64	—	.64
Single score, two sides	—	SF	1.42	—	1.42
Multi-scores, one side	—	SF	.64	—	.64
Multi-scores, two sides	—	SF	1.42	—	1.42
Add for color block, any of above					
Light colors	—	%	14.0	—	—
Medium colors	—	%	22.0	—	—
Dark colors	—	%	30.0	—	—
Add for other than running bond	—	%	—	20.0	—
Glazed Concrete Block Prices are per square foot of wall and include allowance for mortar and waste but no foundation or excavation. 8" high x 16" long, 3/8" joints, no reinforcing or grout included.					
Based on 1.05 blocks per square foot (SF).					
Glazed 1 side					
2" wide	M1@.102	SF	14.60	4.91	19.51
4" wide	M1@.107	SF	17.00	5.16	22.16
6" wide	M1@.111	SF	16.90	5.35	22.25
8" wide	M1@.118	SF	17.90	5.69	23.59
Glazed 2 sides					
4" wide	M1@.122	SF	25.60	5.88	31.48
6" wide	M1@.127	SF	27.10	6.12	33.22
8" wide	M1@.136	SF	27.40	6.55	33.95
Glazed cove base, glazed 1 side, 8" high					
4" length	M1@.127	LF	50.10	6.12	56.22
6" length	M1@.137	LF	37.80	6.60	44.40
8" length	M1@.147	LF	28.90	7.08	35.98
Decorative Concrete Block Prices are per square foot of wall and include allowance for mortar and waste but no foundation, reinforcing, grout or excavation. Regular weight units, 1.05 blocks per SF.					
Split-face hollow block, 8" high x 16" long, 3/8" joints					
4" wide	M1@.110	SF	2.04	5.30	7.34
6" wide	M1@.121	SF	2.15	5.83	7.98
8" wide	M1@.133	SF	2.47	6.41	8.88
10" wide	M1@.140	SF	3.53	6.75	10.28
12" wide	M1@.153	SF	3.47	7.37	10.84
Split-rib (combed) hollow block, 8" high x 16" long, 3/8" joints					
4" wide	M1@.107	SF	2.99	5.16	8.15
6" wide	M1@.115	SF	3.10	5.54	8.64
8" wide	M1@.121	SF	3.43	5.83	9.26
10" wide	M1@.130	SF	4.50	6.26	10.76
12" wide	M1@.146	SF	4.44	7.03	11.47

04 Masonry

	Craft@Hrs	Unit	Material	Labor	Total
Screen block, 3/8" joints					
6" x 6" x 4" wide	M1@.210	SF	4.06	10.10	14.16
8" x 8" x 4" wide (2.25 per SF)	M1@.140	SF	6.13	6.75	12.88
12" x 12" x 4" wide (1 per SF)	M1@.127	SF	3.10	6.12	9.22
8" x 16" x 8" wide (1.11 per SF)	M1@.115	SF	3.23	5.54	8.77
Acoustical slotted block, by rated Noise Reduction Coefficient (NRC)					
4" wide, with metal baffle, NRC, .45 to .55	M1@.121	SF	4.97	5.83	10.80
6" wide, with metal baffle, NRC, .45 to .55	M1@.130	SF	5.86	6.26	12.12
8" wide, with metal baffle, NRC, .45 to .55	M1@.121	SF	7.29	5.83	13.12
8" wide, with fiber filler, NRC, .65 to .75	M1@.143	SF	9.41	6.89	16.30
Concrete Block Bond Beams For door and window openings, no grout or reinforcing included.					
Cost per linear foot of bond beam block					
6" wide, 8" high, 16" long	M1@.068	LF	3.03	3.28	6.31
8" wide, 8" high, 16" long	M1@.072	LF	3.47	3.47	6.94
10" wide, 8" high, 16" long	M1@.079	LF	4.82	3.81	8.63
12" wide, 8" high, 16" long	M1@.089	LF	4.82	4.29	9.11
12" wide, 8" high double bond beam, 16" long	M1@.102	LF	4.82	4.91	9.73
8" wide, 16" high, 16" long	M1@.127	LF	8.10	6.12	14.22
Grout for bond beams, 3,000 PSI concrete, by block size and linear foot of beam, no block or reinforcing included, based on block cavity at 50% of block volume					
8" high x 4" wide, .10 CF per LF	M1@.005	LF	.54	.24	.78
8" high x 6" wide, .15 CF per LF	M1@.010	LF	.80	.48	1.28
8" high x 8" wide, .22 CF per LF	M1@.017	LF	1.18	.82	2.00
8" high x 10" wide, .30 CF per LF	M1@.023	LF	1.61	1.11	2.72
8" high x 12" wide, .40 CF per LF	M1@.032	LF	2.15	1.54	3.69
16" high x 8" wide, .44 CF per LF	M1@.061	LF	2.36	2.94	5.30
16" high x 10" wide, .60 CF per LF	M1@.058	LF	3.22	2.79	6.01
16" high x 12" wide, .80 CF per LF	M1@.079	LF	4.29	3.81	8.10
Grout hollow metal door frame in a masonry wall					
Single door	M1@.668	Ea	13.20	32.20	45.40
Double door	M1@.851	Ea	17.60	41.00	58.60
Additional Costs for Concrete Block					
Sill blocks	M1@.087	LF	1.91	4.19	6.10
Cutting blocks	M1@.137	LF	—	6.60	6.60
Stack bond	—	%	5.0	10.0	—
Add for cut-up jobs	—	%	5.0	5.0	—
Add for institutional grade work	—	%	5.0	15.0	—
Add for colored block	—	%	15.0	—	—
Glass Block Clear 3-7/8" thick block installed in walls to 8' high. Costs shown include 1/4" mortar joints, caulking, wall ties and 6% waste. Heights over 8' to 10' require additional scaffolding and handling and may increase labor costs up to 40%. Mortar is 1 part Portland cement, 1/2 part lime, and 4 parts sand, plus integral waterproofer. Costs for continuous panel reinforcing in horizontal joints are listed below.					
Flat glass block, under 1,000 SF job					
6" x 6", 4 per SF	M1@.323	SF	28.60	15.60	44.20
8" x 8", 2.25 per SF	M1@.245	SF	21.50	11.80	33.30
12" x 12", 1 per SF	M1@.202	SF	26.50	9.73	36.23
Deduct for jobs over 1,000 SF to 5,000 SF	—	%	-4.0	-4.0	—
Deduct for jobs over 5,000 SF	—	%	-10.0	-10.0	—
Deduct for Thinline interior glass block	—	%	-10.0	—	—
Add for thermal control fiberglass inserts	—	%	5.0	5.0	—

04 Masonry

	Craft@Hrs	Unit	Material	Labor	Total
Replacing 8" x 8" x 4" clear glass block, 10 unit minimum					
Per block replaced, add for mortar	M1@.851	Ea	10.90	41.00	51.90
Additional costs for glass block					
Fiberglass or polymeric expansion joints	—	LF	1.47	—	1.47
Reinforcing steel mesh	—	LF	.80	—	.80
Wall anchors, 2' long					
Used where blocks aren't set into a wall	—	Ea	2.94	—	2.94
Asphalt emulsion, 600 LF per gallon	—	Gal	9.98	—	9.98
Waterproof sealant, 180 LF per gallon	—	Gal	16.70	—	16.70
Cleaning block after installation, using sponge and water only					
Per SF cleaned	CL@.023	SF	—	.96	.96

Stone Work The delivered price of stone can be expected to vary widely. These costs include mortar, based on 1/2" joints but no scaffolding. Figures in parentheses show typical quantities installed per 8-hour day by a crew of two.

Rough stone veneer, 4", placed over stud wall					
Lava stone (79 SF)	M4@.202	SF	8.63	9.73	18.36
Rubble stone (40 SF)	M4@.400	SF	12.20	19.30	31.50
Most common veneer (60 SF)	M4@.267	SF	15.30	12.90	28.20
Cut stone					
Thinset granite tile, 1/2" thick (120 SF)	M4@.133	SF	18.00	6.41	24.41
Granite, 7/8" thick, interior (70 SF)	M4@.229	SF	29.40	11.00	40.40
Granite, 1-1/4" thick, exterior (60 SF)	M4@.267	SF	21.90	12.90	34.80
Limestone, 2" thick (70 SF)	M4@.229	SF	27.30	11.00	38.30
Limestone, 3" thick (60 SF)	M4@.267	SF	33.10	12.90	46.00
Marble, 7/8" thick, interior (70 SF)	M4@.229	SF	34.60	11.00	45.60
Marble, 1-1/4" thick, interior (70 SF)	M4@.229	SF	42.60	11.00	53.60
Sandstone, 2" thick (70 SF)	M4@.229	SF	24.40	11.00	35.40
Sandstone, 3" thick (60 SF)	M4@.267	SF	31.60	12.90	44.50
Add for honed finish	—	SF	2.84	—	2.84
Add for polished finish	—	SF	4.97	—	4.97
Marble specialties, typical prices					
Floors, 7/8" thick, exterior (70 SF)	M1@.229	SF	26.30	11.00	37.30
Thresholds, 1-1/4" thick (70 LF)	M1@.229	LF	13.90	11.00	24.90
Bases, 7/8" x 6" (51 LF)	M1@.314	LF	12.40	15.10	27.50
Columns, plain (15 CF)	M1@1.06	CF	147.00	51.10	198.10
Columns, fluted (13 CF)	M1@1.23	CF	202.00	59.30	261.30
Window stools, 5" x 1" (60 LF)	M1@.267	LF	15.30	12.90	28.20
Toilet partitions (1.5 Ea)	M1@10.6	Ea	807.00	511.00	1,318.00
Stair treads, 1-1/4" x 11" (50 LF)	M1@.320	LF	34.10	15.40	49.50
Limestone, rough cut large blocks (39 CF)	M1@.410	CF	42.10	19.80	61.90
Manufactured stone veneer, including mortar, Cultured Stone®					
Prefitted types (160 SF)	M1@.100	SF	8.73	4.82	13.55
Brick veneer type (120 SF)	M1@.133	SF	7.23	6.41	13.64
Random cast type (120 SF)	M1@.133	SF	7.99	6.41	14.40

Quarry Tile Unglazed natural red tile set in a Portland cement bed with mortar joints.

Quarry floor tile					
4" x 4" x 1/2", 1/8" straight joints	M1@.112	SF	4.42	5.40	9.82
6" x 6" x 1/2", 1/4" straight joints	M1@.101	SF	4.14	4.87	9.01
6" x 6" x 3/4", 1/4" straight joints	M1@.105	SF	5.41	5.06	10.47
8" x 8" x 3/4", 3/8" straight joints	M1@.095	SF	5.12	4.58	9.70
8" x 8" x 1/2", 1/4" hexagon joints	M1@.112	SF	5.83	5.40	11.23
Quarry wall tile					
4" x 4" x 1/2", 1/8" straight joints	M1@.125	SF	4.39	6.02	10.41
6" x 6" x 3/4", 1/4" straight joints	M1@.122	SF	5.41	5.88	11.29

04 Masonry

	Craft@Hrs	Unit	Material	Labor	Total
Quarry tile stair treads					
6" x 6" x 3/4", 12" wide tread	M1@.122	LF	5.95	5.88	11.83
Quarry tile window sill					
6" x 6" x 3/4" tile on 6" wide sill	M1@.078	LF	5.72	3.76	9.48
Quarry tile trim or cove base					
5" x 6" x 1/2" straight top	M1@.083	LF	4.39	4.00	8.39
6" x 6" x 3/4" round top	M1@.087	LF	5.12	4.19	9.31
Deduct for tile set in epoxy bed without grout joints	—	SF	—	-1.91	-1.91
Add for tile set in epoxy bed with grout joints	—	SF	1.55	—	1.55
Pavers and Floor Tile					
Brick, excluding platform cost					
Plate, glazed	M1@.114	SF	3.55	5.49	9.04
Laid in sand	M1@.089	SF	2.72	4.29	7.01
Pavers, on concrete, grouted	M1@.107	SF	4.78	5.16	9.94
Add for special patterns	—	%	25.0	35.0	—
Slate	M1@.099	SF	4.18	4.77	8.95
Terrazzo tiles, 1/4" thick					
Standard	M1@.078	SF	6.74	3.76	10.50
Granite	M1@.085	SF	11.00	4.10	15.10
Brick steps	M1@.186	SF	4.25	8.96	13.21
Interlocking Paving Stones These costs include fine sand to fill joints and machine vibration, but no excavation.					
No vapor(or other) barriers					
Interlocking pavers, rectangular, 60mm thick, Orion	M1@.083	SF	2.39	4.00	6.39
Interlocking pavers, hexagonal, 80mm thick, Omni	M1@.085	SF	2.93	4.10	7.03
Interlocking pavers, multi-angle, 80mm thick, Venus	M1@.081	SF	2.55	3.90	6.45
Concrete masonry grid pavers (erosion control)	M1@.061	SF	4.48	2.94	7.42
Add for a 1" sand cushion	M1@.001	SF	.12	.05	.17
Add for a 2" sand cushion	M1@.002	SF	.24	.10	.34
Deduct for over 5,000 SF	—	%	-3.0	-7.0	—
Masonry Lintels and Coping					
Reinforced precast concrete lintels					
4" wide x 8" high, to 6'6" long	M1@.073	LF	11.10	3.52	14.62
6" wide x 8" high, to 6'6" long	M1@.078	LF	19.80	3.76	23.56
8" wide x 8" high, to 6'6" long	M1@.081	LF	20.50	3.90	24.40
10" wide x 8" high, to 6'6" long	M1@.091	LF	26.40	4.38	30.78
4" wide x 8" high, over 6'6" to 10' long	M1@.073	LF	20.80	3.52	24.32
6" wide x 8" high, over 6'6" to 10' long	M1@.077	LF	24.40	3.71	28.11
8" wide x 8" high, over 6'6" to 10' long	M1@.081	LF	25.40	3.90	29.30
10" wide x 8" high, over 6'6" to 10' long	M1@.091	LF	35.00	4.38	39.38
Precast concrete coping, 5" average thickness, 4' to 8' long					
10" wide, gray concrete	M1@.190	LF	18.60	9.15	27.75
12" wide, gray concrete	M1@.200	LF	20.80	9.64	30.44
12" wide, white concrete	M1@.226	LF	51.30	10.90	62.20
Parging (Pargeting), Waterproofing and Dampproofing					
Parging, 2 coats, 1/2" thick	M3@.070	SF	.30	3.54	3.84
Parging, 2 coats, waterproof, 3/4" thick	M3@.085	SF	.42	4.30	4.72
Dampproofing, asphalt primer at 1 gallon per 100 SF,					
Dampproof coat at 30 pounds per 100 SF	CL@.029	SF	.15	1.21	1.36

05 Metals

Craft@Hrs Unit Material Labor Equipment Total

Structural Steel Costs shown below are for 60 to 100 ton jobs up to six stories high where the fabricated structural steel is purchased from a steel fabricator located within 50 miles of the job site. Material costs are for ASTM A36 steel, fabricated according to plans, specifications and AISC recommendations and delivered to the job site with connections attached, piece marked and ready for erection. Labor includes time to unload and handle the steel, erect and plumb, install permanent bolts, weld and all other work usually associated with erecting the steel, including field touch-up painting. Equipment includes a 60 ton crawler mounted crane, plus an electric powered welding machine, an oxygen/acetylene welding and cutting torch, a diesel powered 100 CFM air compressor with pneumatic grinders, ratchet wrenches, hoses, and other tools usually associated with work of this type. Structural steel is usually estimated by the tons of steel in the project. Labor for erection will vary with the weight of steel per linear foot. For example, a member weighing 25 pounds per foot will require more manhours per ton than one weighing 60 pounds per foot.

Structural shapes Estimate the total weight of "bare" fabricated structural shapes and then add 15% to allow for the weight of connections.

Beams, purlins, and girts

Under 20 pounds per LF	H8@14.0	Ton	5,380.00	866.00	471.00	6,717.00
From 20 to 50 lbs per LF	H8@11.0	Ton	3,430.00	681.00	370.00	4,481.00
Over 50 to 75 lbs per LF	H8@9.40	Ton	3,280.00	582.00	316.00	4,178.00
Over 75 to 100 lbs per LF	H8@8.00	Ton	3,190.00	495.00	269.00	3,954.00

Columns

From 1 to 3 lbs per LF	H8@48.0	Ton	7,530.00	2,970.00	1,610.00	12,110.00
Over 3 to 6 lbs per LF	H8@34.8	Ton	7,040.00	2,150.00	1,170.00	10,360.00
Under 20 pounds per LF	H8@12.0	Ton	4,990.00	742.00	404.00	6,136.00
From 20 to 50 lbs per LF	H8@10.0	Ton	3,280.00	619.00	336.00	4,235.00
Over 50 to 75 lbs per LF	H8@9.00	Ton	3,110.00	557.00	303.00	3,970.00
Over 75 to 100 lbs per LF	H8@7.00	Ton	3,110.00	433.00	235.00	3,778.00

Sag rods and X-type bracing

Under 1 pound per LF	H8@82.1	Ton	8,150.00	5,080.00	2,760.00	15,990.00
Over 6 to 10 lbs per LF	H8@28.0	Ton	6,410.00	1,730.00	942.00	9,082.00

Trusses and girders

Under 20 pounds per LF	H8@10.0	Ton	4,960.00	619.00	336.00	5,915.00
From 20 to 50 lbs per LF	H8@7.50	Ton	3,280.00	464.00	252.00	3,996.00
Over 50 to 75 lbs per LF	H8@6.00	Ton	3,110.00	371.00	202.00	3,683.00
Over 75 to 100 lbs per LF	H8@5.00	Ton	3,000.00	309.00	168.00	3,477.00

Structural Steel, Subcontract, by Square Foot of Floor Use these figures for preliminary estimates on buildings with 20,000 to 80,000 SF per story, 100 PSF live load and 14' to 16' story height. A "bay" is the center-to-center distance between columns. Costs assume steel averaging \$2,550 per ton including installation labor and material and the subcontractor's overhead and profit. Include all area under the roof when calculating the total square footage.

Single story

20' x 20' bays (8 to 9 lbs per SF)	—	SF	—	—	—	22.80
30' x 30' bays (10 to 11 lbs per SF)	—	SF	—	—	—	27.90
40' x 40' bays (12 to 13 lbs per SF)	—	SF	—	—	—	33.40

Two story to six story

20' x 20' bays (9 to 10 lbs per SF)	—	SF	—	—	—	25.60
30' x 30' bays (11 to 12 lbs per SF)	—	SF	—	—	—	30.70
40' x 40' bays (13 to 14 lbs per SF)	—	SF	—	—	—	36.20

Tubular Columns Rectangular, round, and square structural columns. When estimating total weight of columns, figure the column weight and add 30% to allow for a shop attached "U"-bracket on the top, a square base plate on the bottom and four anchor bolts. This should be sufficient for columns 15' to 20' in length. Equipment cost includes a 10 ton hydraulic truck-mounted crane plus an electric powered welding machine, an oxygen/acetylene welding

05 Metals

	Craft@Hrs	Unit	Material	Labor	Equipment	Total
and cutting torch, a diesel powered 100 CFM air compressor with pneumatic grinders, ratchet wrenches, hoses, and other tools usually associated with work of this type.						
Rectangular tube columns, in pounds per LF						
3" x 2" to 12" x 4", to 20 lbs per LF	H7@9.00	Ton	3,940.00	574.00	265.00	4,779.00
6" x 4" to 16" x 8", 21 to 50 lbs per LF	H7@8.00	Ton	3,180.00	510.00	235.00	3,925.00
12" x 6" to 20" x 12", 51 to 75 lbs per LF	H7@6.00	Ton	3,120.00	374.00	177.00	3,193.00
14" x 10" to 20" x 12", 76 to 100 lbs/LF	H7@5.00	Ton	3,010.00	319.00	147.00	3,476.00
Round columns, in pounds per LF						
3" to 6" diameter pipe, to 20 lbs per LF	H7@9.00	Ton	4,200.00	574.00	265.00	5,039.00
4" to 12" pipe, 20 to 50 lbs per LF	H7@8.00	Ton	3,390.00	510.00	235.00	4,135.00
6" to 12" pipe, 51 to 75 lbs per LF	H7@6.00	Ton	3,260.00	383.00	177.00	3,820.00
Square tube columns, in pounds per LF						
2" x 2" to 8" x 8", to 20 lbs per LF	H7@9.00	Ton	3,810.00	574.00	265.00	4,649.00
4" x 4" to 12" x 12", 21 to 50 lbs per LF	H7@8.00	Ton	3,120.00	510.00	235.00	3,865.00
8" x 8" to 16" x 16", 51 to 75 lbs per LF	H7@6.00	Ton	3,020.00	383.00	177.00	3,580.00
10" x 10" to 16" x 16", 76 to 100 lbs/LF	H7@5.00	Ton	3,000.00	319.00	47.00	3,366.00
Add for concrete fill in columns, 3,000 PSI design pump mix, placed by pump (including 10% waste)						
	M2@.738	CY	166.00	33.70	6.74	206.44
Space Frame System 10,000 SF or more. Equipment cost shown is for a 15 ton truck crane and a 2 ton truck equipped for work of this type.						
5' module 4.5 lb live load	H5@.146	SF	24.90	8.02	2.58	35.50
4' module, add	H5@.025	SF	3.64	1.37	.44	5.45
Open Web Steel Joists Estimate the total weight of "bare" joists and then add 10% to allow for connections and accessories						
"CS" Series, 8CS2 thru 28CS4						
Under 10 lbs per LF	H8@10.0	Ton	2,400.00	619.00	336.00	3,355.00
Over 10 lbs per LF	H8@8.00	Ton	2,370.00	495.00	269.00	3,134.00
"K" Series, 8K1 thru 18K5						
Under 5 lbs per LF	H8@8.00	Ton	2,210.00	495.00	269.00	2,974.00
Over 5 to 10 lbs per LF	H8@7.00	Ton	2,160.00	433.00	235.00	2,828.00
Over 10 lbs per LF	H8@6.00	Ton	2,040.00	371.00	202.00	2,613.00
Steel Floor and Roof Decking These costs assume a 40,000 SF job not over six stories high. Weight and cost include 10% for waste and connections. Equipment cost shown is for a 15 ton truck crane and a 2 ton truck equipped for work of this type.						
Floor and roof decking, 1-1/2" standard rib, simple non-composite section, non-cellular, shop prime painted finish						
22 gauge, 2.1 lbs per SF	H5@.013	SF	2.30	.71	.23	3.24
20 gauge, 2.5 lbs per SF	H5@.013	SF	2.40	.71	.23	3.34
18 gauge, 3.3 lbs per SF	H5@.013	SF	3.02	.71	.23	3.96
16 gauge, 4.1 lbs per SF	H5@.013	SF	3.34	.71	.23	4.28
Add for galvanized finish	—	SF	.38	—	—	.38
Steel floor deck system. Consists of 18 gauge, 1-1/2" standard rib, shop prime painted steel decking, installed over a structural steel beam and girder support system (cost of support structure not included) covered with 3" thick 6.0 sack mix, 3,000 PSI lightweight ready-mix concrete, placed by pump, reinforced with 6" x 6", W1.4 x W1.4 welded wire mesh. Costs shown assume shoring is not required and include curing and finishing the concrete.						
18 gauge decking	H5@.013	SF	2.40	.71	.23	3.34
Welded wire mesh	RB@.004	SF	.29	.26	—	.55
Lightweight concrete	M2@.006	SF	1.81	.27	.11	2.19
Cure and finish concrete	P8@.011	SF	.22	.51	—	.73
Total floor deck system	—@.034	SF	4.72	1.75	.34	6.81
Add for 16 gauge decking	—	SF	.42	—	—	.42

05 Metals

	Craft@Hrs	Unit	Material	Labor	Equipment	Total
Steel roof deck system. Consists of 18 gauge, 1-1/2" standard rib, shop prime painted steel decking, installed over open web steel joists 4' OC (costs of joists not included) covered with 1-1/4" R-11.1 polystyrene insulation board overlaid with .045" loose laid membrane EPDM (ethylene propylene diene monomer) elastomeric roofing. Joist pricing assumes "H" or "J" Series at 9.45 lbs per LF spanning 20'0", spaced 4' OC.						
18 gauge decking	H5@.013	SF	2.89	.71	.23	3.83
Insulation board	A1@.011	SF	.88	.57	—	1.45
EPDM roofing	R3@.006	SF	.94	.28	—	1.22
Total roof deck system	—@.030	SF	4.71	1.56	.23	6.60
Add for 16 gauge decking	—	SF	.43	—	—	.43
Add for open web steel joists	H5@.005	SF	.36	.27	.09	.72

	Craft@Hrs	Unit	Material	Labor	Equipment	Total
Checkered-Steel Plate Shop fabricated and primed or galvanized after fabrication.						
Checkered steel floor plate,						
1/4", 11-1/4 lbs per SF, painted	IW@.025	SF	18.30	1.67	—	19.97
3/8", 16-1/2 lbs per SF, painted	IW@.025	SF	26.00	1.67	—	27.67
1/4", 11-1/4 lbs per SF, galvanized	IW@.025	SF	19.90	1.67	—	21.57
3/8", 16-1/2 lbs per SF, galvanized	IW@.025	SF	29.40	1.67	—	31.07
Checkered-steel trench cover plate with frame						
1/4", 11-1/4 lbs per SF, primed	IW@.045	SF	24.00	3.00	—	27.00
1/4", 11-1/4 lbs per SF, galvanized	IW@.045	SF	27.70	3.00	—	30.70
3/8", 16-1/2 lbs per SF, primed	IW@.045	SF	34.70	3.00	—	37.70
3/8", 16-1/2 lbs per SF, galvanized	IW@.045	SF	42.00	3.00	—	45.00

	Craft@Hrs	Unit	Material	Labor	Equipment	Total
Spiral Stairways Cost per riser based on a 6" diameter round tubular steel center column, 12 gauge steel pan type 10" treads with 7-1/2" open risers and 2" x 2" tubular steel handrail with 1" x 1" tubular steel posts at each riser. Shop fabricated and primed. Add for railings at top of stairways as required.						
4'0" diameter	H7@.551	Ea	500.00	35.10	4.44	539.54
6'0" diameter	H7@.551	Ea	682.00	35.10	4.44	721.54
8'0" diameter	H7@.551	Ea	864.00	35.10	4.44	903.54
Spiral stairs, 5' diameter. Steel, tubular handrail, composition board treads, prefabricated, shipped unassembled.						
86" to 95" with 10 risers	C8@9.98	Ea	1,870.00	475.00	—	2,345.00
95" to 105" with 11 risers	C8@10.7	Ea	2,070.00	509.00	—	2,579.00
105" to 114" with 12 risers	C8@11.3	Ea	2,210.00	538.00	—	2,748.00
114" to 124" with 13 risers	C8@12.0	Ea	2,470.00	571.00	—	3,041.00
124" to 133" with 14 risers	C8@12.7	Ea	2,810.00	605.00	—	3,415.00
Add for 6' diameter	—	%	24.0	—	—	—
Add for oak treads	—	%	25.0	—	—	—
Add for oak handrail	—	%	45.0	—	—	—

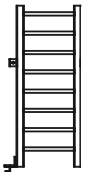

Straight Stairways Cost per LF based on sloping length. Rule of thumb: the sloping length of stairways is the vertical rise times 1.6. Costs assume standard "C"-shape structural steel channels for stringers, 12 gauge steel pan 10" treads with 7-1/2" closed risers. Posts are 2" diameter tubular steel, 5' OC. Handrails are 3'6" high, 1-1/2" diameter 2-rail type, on both sides of the stairs. Installation assumes stairs and landings are attached to an existing structure on two sides.						
3'0" wide	H7@.469	LF	272.00	29.90	13.80	315.70
4'0" wide	H7@.630	LF	363.00	40.20	18.50	421.70
5'0" wide	H7@.781	LF	456.00	49.80	23.00	528.80

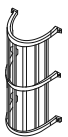

Ladders, vertical type. 1'6" wide, shop fabricated,						
Without safety cage	H7@.300	LF	51.00	19.10	8.82	78.92
With steel safety cage	H7@.550	LF	78.10	35.10	16.20	129.40
Add for galvanized finish	—	LF	5.96	—	—	5.96
Landings. Costs assume standard "C"-shape structural steel channels for joists and frame, 10 gauge steel pan deck areas, shop prime painted. Add for support legs from Structural Steel Section.						
Cost per square foot	H7@.250	SF	144.00	15.90	7.35	167.25
Add for galvanized finish	—	SF	21.00	—	—	21.00

05 Metals

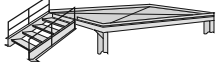
	Craft@Hrs	Unit	Material	Labor	Equipment	Total
Railings, Aluminum, Brass and Wrought Iron						
Aluminum railings. 3'6" high with two 1-1/2" square horizontal rails top and bottom, 5/8" square vertical bars at 4' OC, and 1-1/2" square posts spaced 4' OC. Welded construction with standard mill finish.						
Installed on balconies	H6@.184	LF	39.40	9.96	—	49.36
Installed on stairways	H6@.230	LF	44.30	12.50	—	56.80
Add for anodized finish, bronze or black	—	LF	17.00	—	—	17.00
						
Brass railings. Round tubular type, bright finish, .050" wall commercial quality with supports at 3' OC attached to existing structure using brass screws. Labor includes layout, measure, cut and end preparation						
1-1/2" tubing	H6@.058	LF	18.60	3.14	—	21.74
2" tubing	H6@.058	LF	24.40	3.14	—	27.54
Fittings, slip-on type, no soldering or brazing required						
1-1/2" elbows	H6@.092	Ea	33.00	4.98	—	37.98
1-1/2" bracket	H6@.166	Ea	23.20	8.99	—	32.19
2" elbows	H6@.115	Ea	40.40	6.23	—	46.63
2" bracket	H6@.166	Ea	24.40	8.99	—	33.39
Splices						
1-1/2" splice	H6@.092	Ea	13.70	4.98	—	18.68
2" splice	H6@.115	Ea	16.80	6.23	—	23.03
Wrought iron railings. Standard 3'6" high, welded steel construction, shop prime painted, attached to existing structure						
Stock patterns	H6@.171	LF	21.80	9.26	—	31.06
Custom patterns	H6@.287	LF	32.60	15.50	—	48.10
Stairway handrails	H6@.343	LF	36.10	18.60	—	54.70
Steel Handrails, Kickplates, and Railings Material costs assume shop fabrication and assembly, prime painted and erection bolts. Equipment cost includes a 10-ton hydraulic truck-mounted crane, an electric powered welding machine, an oxygen/acetylene welding rig, a diesel powered 100 CFM air compressor and accessories.						
Handrails. Wall mounted, with brackets 5' OC, based on 12' lengths, welded steel, shop prime painted						
1-1/4" diameter rail	H7@.092	LF	14.20	5.87	2.71	22.78
1-1/2" diameter rail	H7@.102	LF	15.60	6.50	3.00	25.10
Add for galvanized finish	—	LF	1.89	—	—	1.89
Kickplates, 1/4" thick flat steel plate, shop prime painted, attached to steel railings, stairways or landings						
4" high	H7@.058	LF	8.82	3.70	1.71	14.23
6" high	H7@.069	LF	9.56	4.40	2.03	15.99
Add for galvanized finish	—	LF	1.41	—	—	1.41
Pipe and chain railings. Welded steel pipe posts with U-brackets attached to accept 1/4" chain, shop prime painted. Installed in existing embedded sleeves. Posts are 5'0" long (1'6" in the sleeve and 3'6" above grade). Usual spacing is 4' OC. Add chain per lineal foot						
1-1/4" diameter post	H7@.287	Ea	19.50	18.30	—	37.80
1-1/2" diameter post	H7@.287	Ea	24.10	18.30	—	42.40
2" diameter post	H7@.343	Ea	32.20	21.90	—	54.10
3" diameter post	H7@.343	Ea	63.70	21.90	—	85.60
Add for galvanized finish	—	Ea	6.70	—	—	6.70
Chain, 1/4" diameter galvanized	H7@.058	LF	6.49	3.70	—	10.19
Railings. Floor mounted, 3'6" high with posts 5' OC, based on 12' length, welded steel, shop prime painted						
1-1/4" diameter rails and posts						
2-rail type	H7@.115	LF	54.60	7.33	3.38	65.31
3-rail type	H7@.125	LF	81.80	7.97	3.68	93.45
1-1/2" diameter rails and posts						
2-rail type	H7@.125	LF	57.10	7.97	3.68	68.75
3-rail type	H7@.137	LF	86.80	8.74	4.03	99.57
Add for galvanized finish	—	LF	16.70	—	—	16.70

05 Metals

	Craft@Hrs	Unit	Material	Labor	Total
Fabricated metals					
Catch basin grating and frame					
24" x 24", standard duty	CL@8.68	Ea	512.00	362.00	874.00
Manhole rings with cover					
24", 330 lbs	CL@6.80	Ea	496.00	283.00	779.00
30", 400 lbs	CL@6.80	Ea	512.00	283.00	795.00
38", 730 lbs	CL@6.80	Ea	1,420.00	283.00	1,703.00
Welded steel grating Weight shown is approximate. Costs shown are per square foot of grating, shop prime painted or galvanized after fabrication as shown					
Grating bars as shown, 1/2" cross bars at 4" OC					
1-1/4" x 3/16" at 1-1/4" OC, 9 lbs per SF, painted	IW@.019	SF	11.20	1.27	12.47
1-1/4" x 3/16" at 1-1/4" OC, 9 lbs per SF, galvanized	IW@.019	SF	13.90	1.27	15.17
Add for banding on edges	—	LF	5.88	—	5.88
2" x 1/4" at 1-1/4" OC, 18.7 lbs per SF, painted	IW@.026	SF	26.40	1.73	28.13
2" x 1/4" at 1-1/4" OC, 18.7 lbs per SF, galvanized	IW@.026	SF	35.60	1.73	37.33
Add for banding on edges	—	LF	8.76	—	8.76
Add for toe-plates, steel, shop prime painted					
1/4" thick x 4" high attached after grating is in place	IW@.048	LF	11.30	3.20	14.50
Steel fabrications					
Canopy framing, steel	IW@.009	Lb	1.81	.60	2.41
Miscellaneous supports, steel	IW@.019	Lb	2.98	1.27	4.25
Miscellaneous supports, aluminum	IW@.061	Lb	19.20	4.07	23.27
Embedded steel (embedded in concrete)					
Light, to 20 lbs per LF	T3@.042	Lb	3.82	2.26	6.08
Medium, over 20 to 50 lbs per LF	T3@.035	Lb	3.29	1.88	5.17
Heavy, over 50 lbs per LF	T3@.025	Lb	2.77	1.34	4.11
Channel sill, 1/8" steel, 1-1/2" x 8" wide	T3@.131	LF	28.50	7.04	35.54
Angle sill, 1/8" steel, 1-1/2" x 1-1/2"	T3@.095	LF	9.01	5.10	14.11
Fire escapes, ladder and balcony, per floor	IW@16.5	Ea	3,390.00	1,100.00	4,490.00
Grey iron foundry items	T3@.014	Lb	1.66	.75	2.41
Stair nosing, 2-1/2" x 2-1/2", set in concrete	T3@.139	LF	14.20	7.47	21.67
Cast iron					
Lightweight sections	T3@.012	Lb	1.31	.64	1.95
Heavy section	T3@.010	Lb	1.05	.54	1.59
Cast column bases					
Iron, 16" x 16", custom	T3@.759	Ea	115.00	40.80	155.80
Iron, 32" x 32", custom	T3@1.54	Ea	480.00	82.70	562.70
Aluminum, 8" column, stock	T3@.245	Ea	26.80	13.20	40.00
Aluminum, 10" column, stock	T3@.245	Ea	33.80	13.20	47.00
Wheel type corner guards, per LF of height	T3@.502	LF	83.00	27.00	110.00
Angle corner guards, with anchors	T3@.018	Lb	2.46	.97	3.43
Channel door frames, with anchors	T3@.012	Lb	2.28	.64	2.92
Steel lintels, painted	T3@.013	Lb	1.38	.70	2.08
Steel lintels, galvanized	T3@.013	Lb	1.82	.70	2.52
Anodizing Add to cost of fabrication					
Aluminum	—	%	15.0	—	—
Bronze	—	%	30.0	—	—
Black	—	%	50.0	—	—
Galvanizing, add to cost of fabrication	—	Lb	.74	—	.74

05 Metals

	Craft@Hrs	Unit	Material	Labor	Total
Ornamental Metal					
Ornamental screens, aluminum	H6@.135	SF	45.30	7.31	52.61
Ornamental screens extruded metal	H6@.151	SF	38.00	8.18	46.18
Gates, wrought iron, 6' x 7', typical installed cost	—	Ea	—	—	1,680.00
Sun screens, aluminum stock design, manual	H6@.075	SF	48.80	4.06	52.86
Sun screens, aluminum stock design, motorized	H6@.102	SF	88.60	5.52	94.12
Aluminum work, general fabrication	H6@.160	Lb	24.20	8.66	32.86
Brass and bronze work, general fabrication	H6@.079	Lb	35.20	4.28	39.48
Stainless steel, general fabrication	H6@.152	Lb	28.40	8.23	36.63

Security Gratings

Door grating, 1" tool steel vertical bars at 4" OC, 3/8" x 2-1/4" steel frame and horizontal bars at 18" OC, 3' x 7' overall	H6@10.5	Ea	2,350.00	569.00	2,919.00
Add for butt hinges and locks, per door	H6@2.67	Ea	719.00	145.00	864.00
Add for field painting, per door	H6@1.15	Ea	10.90	62.30	73.20
Window grating, tool steel vertical bars at 4" OC, 3/8" x 2-1/4" steel frame, horizontal bars 6" OC, 20" x 30" overall set with 1/2" bolts at 6" OC	H6@3.21	Ea	315.00	174.00	489.00
Louver vent grating, 1" x 3/16", "I" bearing bars 1-3/16" OC with 3/16" spaced bars 4" OC and banded ends, set with 1/2" bolts at 1" OC, prime painted	H6@.114	SF	38.50	6.17	44.67
Steel plate window covers, hinged, 3/8" plate steel, 32" W x 48" H overall, 10 lbs per SF, including hardware	H6@.150	SF	17.60	8.12	25.72

Steel fabrication on site These costs are for work at the job site and assume engineering and design, including detail drawings sufficient to do the work, have been prepared by others at no cost to the installing contractor. Costs are based on ASTM A36 all-purpose carbon steel, which is widely used in building construction. Equipment cost includes a 1-1/4-ton flatbed truck equipped with a diesel powered welding machine, an oxygen/acetylene welding and cutting torch, a diesel powered 100 CFM air compressor with pneumatic grinders, ratchet wrenches, hoses and hand tools appropriate for this type of work. Material cost for the steel is not included.

	Craft@Hrs	Unit	Material	Labor	Equipment	Total
Flat plate, cutting and drilling holes						
Flame cutting. Labor shown includes layout, marking, cutting and grinding of finished cut						
Square cut, thickness of plate as shown						
1/4", 5/16" or 3/8"	IW@.020	LF	—	1.33	1.15	2.48
1/2", 5/8" or 3/4"	IW@.025	LF	—	1.67	1.44	3.11
7/8", 1" or 1-1/4"	IW@.030	LF	—	2.00	1.73	3.73
Bevel cut 30 to 45 degrees, thickness of plate as shown						
1/4", 5/16" or 3/8"	IW@.030	LF	—	2.00	1.73	3.73
1/2", 5/8" or 3/4"	IW@.035	LF	—	2.33	2.02	4.35
7/8", 1" or 1-1/4"	IW@.043	LF	—	2.87	2.48	5.35
Drill holes. Using a hand-held drill motor. Labor shown includes layout, drill and ream holes with plate thickness and hole size as shown (note: hole size is usually 1/16" greater than bolt diameter)						
1/4", 5/16" or 3/8" plate thickness, 5/16", 3/8" or 1/2" hole	IW@.084	Ea	—	5.60	4.84	10.44
1/2", 5/8" or 3/4" plate thickness, 9/16", 3/4" or 13/16" hole	IW@.134	Ea	—	8.93	7.72	16.65
7/8", 1" or 1-1/4" plate thickness, 1", 1-1/16" or 1-5/16" hole	IW@.200	Ea	—	13.30	11.50	24.80

05 Metals

	Craft@Hrs	Unit	Material	Labor	Equipment	Total
Welding Using manual inert gas shielded arc electric welding and coated electrodes (rods) of the appropriate size and type. Equipment is an electric welding machine with amperage suitable for the welding rod being used. Labor includes layout, fit-up and weld.						
Fillet welds for attaching base plates, clip angles, gussets. Welding in flat position						
Size of continuous fillet weld						
3/16"	IW@.300	LF	—	20.00	17.30	37.30
1/4"	IW@.400	LF	—	26.70	23.10	49.80
3/8"	IW@.585	LF	—	39.00	32.70	71.70
1/2"	IW@.810	LF	—	54.00	46.70	100.70
5/8"	IW@1.00	LF	—	66.60	57.70	124.30
3/4"	IW@1.20	LF	—	80.00	69.20	149.20
Buttweld joints, 100% penetration, flat plates						
Thickness at joint						
3/16"	IW@.200	LF	—	13.30	11.50	24.80
1/4"	IW@.250	LF	—	16.70	14.40	31.10
3/8"	IW@.440	LF	—	29.30	25.40	54.70
1/2"	IW@.660	LF	—	44.00	38.10	82.10
5/8"	IW@.825	LF	—	55.00	47.60	102.60
3/4"	IW@1.05	LF	—	70.00	60.50	130.50

06 Wood and Composites

	Craft@Hrs	Unit	Material	Labor	Total
Rough Carpentry Industrial and commercial work. Costs include 10% waste. Using standard and better dimension lumber at the following prices:					
2" x 4"	—	MBF	1,240.00	—	1,240.00
2" x 6"	—	MBF	1,260.00	—	1,260.00
2" x 8"	—	MBF	1,110.00	—	1,110.00
2" x 10"	—	MBF	1,180.00	—	1,180.00
2" x 12"	—	MBF	1,350.00	—	1,350.00
4" x 4"	—	MBF	1,570.00	—	1,570.00
4" x 6"	—	MBF	1,530.00	—	1,530.00
4" x 8"	—	MBF	1,490.00	—	1,490.00
4" x 10"	—	MBF	1,660.00	—	1,660.00
4" x 12"	—	MBF	1,360.00	—	1,360.00
6" x 6"	—	MBF	2,220.00	—	2,220.00
6" x 8"	—	MBF	2,250.00	—	2,250.00
6" x 10"	—	MBF	2,270.00	—	2,270.00
6" x 12"	—	MBF	2,290.00	—	2,290.00
Add for ACQ treatment	—	MBF	285.00	—	285.00
Stud walls, including plates, blocking, headers and diagonal bracing, per SF of wall measured one side					
2" x 4", 8' high, 16" OC, 1.1 BF per SF	C8@.021	SF	1.50	1.00	2.50
2" x 4", 10' high, 16" OC, 1.0 BF per SF	C8@.021	SF	1.36	1.00	2.36
2" x 6", 8' high, 16" OC, 1.6 BF per SF	C8@.031	SF	2.21	1.48	3.69
2" x 6", 10' high, 16" OC, 1.5 BF per SF	C8@.030	SF	2.08	1.43	3.51
2" x 6", 8' high, 12" OC, 2.0 BF per SF	C8@.037	SF	2.77	1.76	4.53
2" x 4", 8' high, 8" OC, staggered on 2" x 6" plates, 1.8 BF per SF	C8@.034	SF	2.45	1.62	4.07
Pier caps, .60 ACQ treated					
2" x 6"	C8@.024	LF	1.54	1.14	2.68
Mud sills, ACQ treated, add bolts or fastener					
Bolted, 2" x 4"	C8@.023	LF	1.52	1.09	2.61
Bolted, 2" x 6"	C8@.024	LF	1.54	1.14	2.68
Shot, 2" x 4"	C8@.018	LF	1.85	.86	2.71
Shot, 2" x 6"	C8@.020	LF	1.54	.95	2.49

06 Wood and Composites

	Craft@Hrs	Unit	Material	Labor	Total
Plates (add for .60 ACQ treatment if required)					
2" x 4"	C8@.013	LF	.91	.62	1.53
2" x 6"	C8@.016	LF	1.38	.76	2.14
Posts, #1 structural					
4" x 4"	C8@.110	LF	2.30	5.24	7.54
6" x 6"	C8@.145	LF	7.34	6.90	14.24
Headers, 4" x 12"					
Diagonal bracing, 1" x 4", let in	C8@.021	LF	.81	1.00	1.81
Blocking and nailers, 2" x 6"	C8@.034	LF	1.38	1.62	3.00
Blocking, solid diagonal bracing, 2" x 4"	C8@.023	LF	.91	1.09	2.00
Beams and girders, #2 & better					
4" x 8" to 4" x 12"	C8@.094	LF	7.31	4.47	11.78
6" x 8" to 6" x 12"	C8@.115	LF	14.70	5.47	20.17
Ceiling joists and blocking, including rim joists, per LF of joist					
2" x 6"	C8@.028	LF	1.38	1.33	2.71
2" x 8"	C8@.037	LF	1.62	1.76	3.38
2" x 10"	C8@.046	LF	2.17	2.19	4.36
2" x 12"	C8@.057	LF	2.98	2.71	5.69
Floor joists and blocking including rim joists and 6% waste, per LF of joist					
2" x 6", 1.06 BF per LF	C8@.017	LF	1.38	.81	2.19
2" x 8", 1.41 BF per LF	C8@.018	LF	1.62	.86	2.48
2" x 10", 1.77 BF per LF	C8@.019	LF	2.17	.90	3.07
2" x 12", 2.12 BF per LF	C8@.021	LF	2.98	1.00	3.98
Purlins, struts, ridge boards					
4" x 10"	C8@.050	LF	6.09	2.38	8.47
4" x 12"	C8@.055	LF	6.00	2.62	8.62
6" x 10"	C8@.066	LF	12.20	3.14	15.34
6" x 12"	C8@.066	LF	14.70	3.14	17.84
Rafters and outriggers, to 4 in 12 pitch					
2" x 4" to 2" x 8"	C8@.033	LF	1.62	1.57	3.19
2" x 10" to 2" x 12"	C8@.036	LF	2.98	1.71	4.69
Add for over 4 in 12 pitch roof	—	%	—	30.0	—
Rafters, including frieze blocks, ribbon, strongbacks, 24" OC, per SF of roof plan area, Std & Btr.					
2" x 4" .44 BF per SF	C8@.015	LF	.54	.71	1.25
2" x 6" .65 BF per SF	C8@.021	LF	.82	1.00	1.82
2" x 8" .86 BF per SF	C8@.027	LF	.95	1.29	2.24
2" x 10" 1.10 BF per SF	C8@.031	LF	1.30	1.48	2.78
2" x 12" 1.40 BF per SF	C8@.041	LF	1.89	1.95	3.84

Sills and Ledgers Bolted to Concrete or Masonry Walls Costs are per linear foot of Standard and Better pressure treated sill or ledger with anchor bolt holes drilled each 2'6" center. Labor costs include handling, measuring, cutting to length and drilling holes at floor level and installation working on a scaffold 10' to 20' above floor level. Figures in parentheses show the board feet per linear foot of sill or ledger. Costs shown include 5% waste. For scheduling purposes, estimate that a crew of 2 can install 150 to 200 LF of sills with a single row of anchor bolts in an 8-hour day when working from scaffolds. Estimate that a crew of 2 can install 150 to 175 LF of ledgers with a single row of anchor bolt holes or 50 to 60 LF of ledgers with a double row of anchor bolt holes in an 8-hour day working from scaffolds. Add the cost of anchor bolts and scaffold, if required.

Sills with a single row of anchor bolt holes

2" x 4" (0.70 BF per LF)	C8@.040	LF	1.13	1.90	3.03
2" x 6" (1.05 BF per LF)	C8@.040	LF	1.38	1.90	3.28
2" x 8" (1.40 BF per LF)	C8@.040	LF	1.95	1.90	3.85
2" x 10" (1.75 BF per LF)	C8@.040	LF	3.26	1.90	5.16
2" x 12" (2.10 BF per LF)	C8@.040	LF	4.50	1.90	6.40
4" x 6" (2.10 BF per LF)	C8@.051	LF	4.89	2.43	7.32
4" x 8" (2.80 BF per LF)	C8@.051	LF	5.97	2.43	8.40
4" x 10" (3.33 BF per LF)	C8@.059	LF	7.28	2.81	10.09
4" x 12" (4.20 BF per LF)	C8@.059	LF	9.62	2.81	12.43

06 Wood and Composites

	Craft@Hrs	Unit	Material	Labor	Total
Ledgers with a single row of anchor bolt holes					
2" x 4" (0.70 BF per LF)	C8@.059	LF	1.13	2.81	3.94
4" x 6" (2.10 BF per LF)	C8@.079	LF	4.89	3.76	8.65
4" x 8" (2.80 BF per LF)	C8@.079	LF	5.97	3.76	9.73
Ledgers with a double row of anchor bolt holes					
4" x 4" (1.40 BF per LF)	C8@.120	LF	2.72	5.71	8.43
4" x 6" (2.10 BF per LF)	C8@.160	LF	4.89	7.62	12.51
4" x 8" (2.80 BF per LF)	C8@.160	LF	5.97	7.62	13.59
4" x 12" (4.20 BF per LF)	C8@.250	LF	9.62	11.90	21.52
Sheathing Includes nails and normal waste					
Floors, hand nailed, underlayment C-D Grade plywood					
1/2"	C8@.012	SF	1.63	.57	2.20
5/8"	C8@.012	SF	1.58	.57	2.15
3/4"	C8@.013	SF	1.60	.62	2.22
Floors, machine nailed OSB					
7/16" x 4' x 8'	C8@.009	SF	1.11	.43	1.54
7/16" x 4' x 9'	C8@.009	SF	1.62	.43	2.05
7/16" x 4' x 10'	C8@.009	SF	1.42	.43	1.85
15/32" 4' x 8'	C8@.009	SF	1.28	.43	1.71
1/2" x 4' x 8'	C8@.009	SF	1.14	.43	1.57
5/8" x 4' x 8'	C8@.010	SF	1.72	.48	2.20
5/8" x 4' x 8', tongue and groove	C8@.010	SF	2.23	.48	2.71
23/32" x 4' x 8'	C8@.010	SF	2.66	.48	3.14
23/32" 4' x 8' subfloor	C8@.010	SF	2.00	.48	2.48
3/4" x 4' x 8', tongue and groove	C8@.011	SF	1.99	.52	2.51
1-1/8" x 4' x 8', tongue and groove	C8@.015	SF	5.71	.71	6.42
15/32" x 4' x 8', hibor treated	C8@.011	SF	2.49	.52	3.01
Walls, B-D sanded, standard, Interior Grade plywood					
1/4"	C8@.015	SF	1.04	.71	1.75
3/8"	C8@.015	SF	1.39	.71	2.10
1/2"	C8@.016	SF	1.75	.76	2.51
5/8"	C8@.018	SF	1.55	.86	2.41
3/4"	C8@.018	SF	1.77	.86	2.63
5/8" fire retardant, A-B, screwed to metal frame	C8@.026	SF	2.23	1.24	3.47
Walls, Exterior Grade C-D plywood					
1/2"	C8@.016	SF	1.63	.76	2.39
5/8"	C8@.018	SF	1.58	.86	2.44
3/4"	C8@.020	SF	1.60	.95	2.55
3/8" rough sawn T-1-11	C8@.018	SF	1.83	.86	2.69
5/8" rough sawn T-1-11	C8@.018	SF	2.43	.86	3.29
5/8" rough sawn RBB	C8@.018	SF	2.43	.86	3.29
Walls, OSB					
11/32" or 3/8" x 4' x 8'	C8@.013	SF	1.50	.62	2.12
7/16" x 4' x 8'	C8@.015	SF	1.11	.71	1.82
7/16" x 4' x 9'	C8@.015	SF	1.62	.71	2.33
7/16" x 4' x 10'	C8@.015	SF	1.42	.71	2.13
15/32" 4' x 8'	C8@.015	SF	1.28	.71	1.99
1/2" x 4' x 8'	C8@.018	SF	1.14	.86	2.00
5/8" x 4' x 8'	C8@.018	SF	1.72	.86	2.58
5/8" x 4' x 8', tongue and groove	C8@.018	SF	2.23	.86	3.09
23/32" x 4' x 8'	C8@.020	SF	2.66	.95	3.61
15/32" x 4' x 10', Structural 1	C8@.020	SF	2.26	.95	3.21
Add for nailing shear walls	—	%	—	20.0	—

06 Wood and Composites

	Craft@Hrs	Unit	Material	Labor	Total
Roofs, C-D Exterior plywood, machine nailed					
3/8"	C8@.009	SF	.93	.43	1.36
1/2"	C8@.009	SF	1.63	.43	2.06
5/8"	C8@.009	SF	1.58	.43	2.01
3/4"	C8@.011	SF	1.60	.52	2.12
Roofs, OSB, machine nailed					
11/32" or 3/8" x 4' x 8'	C8@.009	SF	1.50	.43	1.93
7/16" x 4' x 8'	C8@.009	SF	1.11	.43	1.54
7/16" x 4' x 9'	C8@.009	SF	1.62	.43	2.05
7/16" x 4' x 10'	C8@.009	SF	1.42	.43	1.85
15/32" 4' x 8'	C8@.009	SF	1.28	.43	1.71
1/2" x 4' x 8'	C8@.009	SF	1.14	.43	1.57
5/8" x 4' x 8'	C8@.010	SF	1.72	.48	2.20
5/8" x 4' x 8', tongue and groove	C8@.010	SF	2.23	.48	2.71
23/32" x 4' x 8'	C8@.010	SF	2.66	.48	3.14
3/4" x 4' x 8', tongue and groove	C8@.011	SF	1.99	.52	2.51
Blocking for panel joints, 2" x 4"	C8@.010	LF	.91	.48	1.39
Lumber floor sheathing					
Diagonal, 1" x 6" Standard and Better 1.14 BF per SF	C8@.018	SF	2.70	.86	3.56
Straight 2" x 6" Commercial Grade T&G fir 2.28 BF per SF	C8@.032	SF	2.87	1.52	4.39
Straight 2" x 6" Commercial Grade T&G cedar 2.28 BF per SF	C8@.032	SF	14.10	1.52	15.62
Timber deck, Southern Pine, 5/4" x 6", Premium Grade 1.25 BF per SF	C8@.012	SF	4.09	.57	4.66
Lumber wall sheathing, diagonal, 1" x 6"					
Standard and Better, 1.14 BF per SF	C8@.024	SF	4.28	1.14	5.42
Lumber roof sheathing, diagonal, 1" x 6"					
Standard and Better, 1.14 BF per SF	C8@.018	SF	4.28	.86	5.14

Panelized Wood Roof Systems The costs shown will apply on 20,000 to 30,000 SF jobs where roof panels are fabricated near the point of installation and moved into place with a forklift. Costs will be higher on smaller jobs and jobs with poor access. 4' x 8' and 4' x 10' roof panels are made of plywood or OSB nailed to 2" x 4" or 2" x 6" stiffeners spaced 24" on centers and running the long dimension of the panel. Based on fabricated panels lifted by forklift (with metal hangers attached) and nailed to 4" x 12" or 4" x 14" roof purlins spaced 8' on center. Equipment cost is for a 4-ton forklift (40' lift), a truck with hand tools, a gas powered air compressor with air hoses and two pneumatic-operated nailing guns. Costs are per 1,000 square feet (MSF) of roof surface and do not include roof supports except as noted.

	Craft@Hrs	Unit	Material	Labor	Equipment	Total
--	-----------	------	----------	-------	-----------	-------

For scheduling purposes, estimate that a crew of 5 can fabricate 6,000 to 6,400 SF of 4' x 8' or 4' x 10' panels in an 8-hour day. Estimate that the same crew of 5 can install and nail down 7,600 to 8,000 SF of panels in an 8-hour day.

Based on the following material costs:

2" x 4" stiffeners	—	MBF	1,240.00	—	—	1,240.00
2" x 6" stiffeners	—	MBF	1,260.00	—	—	1,260.00
Purlins	—	MBF	1,360.00	—	—	1,360.00
1/2" CDX plywood	—	MSF	1,550.00	—	—	1,550.00
1/2" OSB sheathing	—	MSF	1,410.00	—	—	1,410.00

06 Wood and Composites

	Craft@Hrs	Unit	Material	Labor	Equipment	Total
4' x 8' roof panels						
With 1/2" CDX structural #1 plywood attached to 2" x 4" Construction Grade fir stiffeners						
Panels fabricated, ready to install	F6@6.60	MSF	2,210.00	328.00	107.00	2,645.00
Equipment & labor						
to install and nail panels	F6@5.21	MSF	—	259.00	84.60	343.60
Total installed cost, 4' x 8' panels	F6@11.8	MSF	2,210.00	587.00	191.60	2,988.60
With 1/2" OSB structural sheathing attached to 2" x 4" Construction Grade fir stiffeners						
Panels fabricated, ready to install	F6@6.60	MSF	2,070.00	328.00	107.00	2,505.00
Equipment & labor						
to install and nail panels	F6@5.21	MSF	—	259.00	84.60	343.60
Total installed cost, 4' x 8' panels	F6@11.8	MSF	2,070.00	587.00	191.60	2,848.60
4' x 10' roof panels						
With 1/2" CDX structural #1 plywood attached to 2" x 6" Construction Grade fir stiffeners						
Panels fabricated, ready to install	F6@6.20	MSF	2,480.00	308.00	100.00	2,888.00
Equipment & labor						
to install and nail panels	F6@4.90	MSF	—	243.00	79.30	322.30
Total installed cost, 4' x 10' panels	F6@11.1	MSF	2,480.00	551.00	179.30	3,210.30
With 1/2" OSB structural sheathing attached to 2" x 6" Construction Grade fir stiffeners						
Panels fabricated, ready to install	F6@6.20	MSF	2,340.00	308.00	100.00	2,748.00
Equipment & labor						
to install and nail panels	F6@4.90	MSF	—	243.00	79.30	322.30
Total installed cost, 4' x 10' panels	F6@11.1	MSF	2,340.00	551.00	179.30	3,070.30
8' x 20' and 8' x 32' roof panels						
These panels can be fabricated on site using the same crew and equipment as shown in the preceding section. However, the stiffeners run across the short dimension of the panel and one purlin is attached to the outside edge of the long dimension of each panel before lifting into place. Figures below include the cost of purlins but not supporting beams. For scheduling purposes, estimate that a crew of 5 can fabricate 6,400 to 7,000 SF of 8' x 20' or 8' x 32' panels in an 8-hour day. Estimate that the same crew of 5 can install and nail down 10,000 to 11,000 SF of panels in an 8-hour day.						
8' x 20' roof panels with purlins attached						
4' x 10' x 1/2" CDX structural #1 plywood attached to 2" x 4" Const. Grade fir stiffeners and 4" x 12" #1 Grade fir purlins						
Panels fabricated, ready to install	F6@6.23	MSF	3,660.00	309.00	101.00	4,070.00
Equipment & labor						
to install and nail panels	F6@3.96	MSF	—	197.00	79.70	276.70
Total installed cost, 8' x 20' panels	F6@10.2	MSF	3,660.00	506.00	180.70	4,346.70
8' x 20' x 1/2" OSB structural sheathing attached to 2" x 4" Const. Grade fir stiffeners and 4" x 12" #1 Grade fir purlins						
Panels fabricated, ready to install	F6@6.23	MSF	3,520.00	309.00	101.00	3,930.00
Equipment & labor						
to install and nail panels	F6@3.96	MSF	—	197.00	79.70	276.70
Total installed cost, 8' x 20' panels	F6@10.2	MSF	3,520.00	506.00	180.70	4,206.70
8' x 32' panel with purlins attached						
4' x 8' x 1/2" CDX structural #1 plywood attached to 2" x 4" Const. Grade fir stiffeners and 4" x 12" #1 Grade fir purlins						
Panels fabricated, ready to install	F6@5.82	MSF	3,940.00	289.00	94.50	4,323.50
Equipment & labor						
to install and nail panels	F6@3.54	MSF	—	176.00	57.20	233.20
Total installed cost, 8' x 32' panels	F6@9.36	MSF	3,940.00	465.00	151.70	4,556.70
4' x 8' x 1/2" OSB structural sheathing attached to 2" x 4" Const. Grade fir stiffeners and 4" x 12" #1 Grade fir purlins						
Panels fabricated, ready to install	F6@5.82	MSF	3,790.00	289.00	94.50	4,173.50
Equipment & labor						
to install and nail panels	F6@3.54	MSF	—	176.00	57.20	233.20
Total installed cost, 8' x 32' panels	F6@9.36	MSF	3,790.00	465.00	151.70	4,406.70
Add to any of the panel costs for 5/8" CDX #1 structural plywood, instead of 1/2" attached before panels are erected						
	—	MSF	497.00	—	—	497.00

06 Wood and Composites

	Craft@Hrs	Unit	Material	Labor	Equipment	Total
Deduct to any of the panel costs for 15/32" OSB Structural I sheathing, instead of 1/2" attached before panels are erected						
	—	MSF	-194.00	—	—	-194.00
Add for roof hatch opening, includes reinforced opening and curb. Does not include roof hatch, see below						
2" x 4" roof system	F6@.055	SF	7.12	2.73	—	9.85
2" x 6" roof system	F6@.060	SF	9.80	2.98	—	12.78
Panelized Wood Wall Panels These costs will apply on jobs with 20,000 to 30,000 SF of wall panels. Panel material costs are for prefabricated panels purchased from a modular plant located within 50 miles of the job site. Costs will be higher on smaller jobs and on jobs with poor access. Costs assume wall panels are fabricated according to job plans and specifications, delivered piece-marked, ready to install and finish. Labor costs for installation of panels are listed at the end of this section and include unloading and handling, sorting, moving the panels into position using a forklift, installing and nailing. Maximum panel height is usually 12'. Equipment cost includes a forklift, hand tools, a portable air compressor with air hoses and two pneumatic-operated nailing guns. Costs are per square foot of wall, measured on one face. For scheduling purposes, estimate that a crew of 4 can place and fasten 3,500 to 4,500 SF of panels in an 8-hour day.						
2" x 4" studs 16" OC with gypsum wallboard on both sides						
1/2" wallboard	—	SF	2.39	—	—	2.39
5/8" wallboard	—	SF	2.48	—	—	2.48
2" x 4" studs 16" OC with gypsum wallboard inside and plywood or OSB outside						
1/2" wallboard and 1/2" CDX plywood	—	SF	3.49	—	—	3.49
1/2" wallboard and 1/2" OSB sheathing	—	SF	3.36	—	—	3.36
1/2" wallboard and 5/8" CDX plywood	—	SF	4.26	—	—	4.26
1/2" wallboard and 5/8" OSB sheathing	—	SF	3.59	—	—	3.59
5/8" wallboard and 1/2" CDX plywood	—	SF	3.54	—	—	3.54
5/8" wallboard and 1/2" OSB sheathing	—	SF	3.40	—	—	3.40
5/8" wallboard and 5/8" CDX plywood	—	SF	4.31	—	—	4.31
5/8" wallboard and 5/8" OSB sheathing	—	SF	3.63	—	—	3.63
2" x 6" studs 12" OC with gypsum wallboard on both sides						
1/2" wallboard	—	SF	3.22	—	—	3.22
5/8" wallboard	—	SF	3.26	—	—	3.26
2" x 6" studs 12" OC with gypsum wallboard inside and plywood or OSB outside						
1/2" wallboard and 1/2" CDX plywood	—	SF	4.77	—	—	4.77
1/2" wallboard and 1/2" OSB sheathing	—	SF	4.63	—	—	4.63
1/2" wallboard and 5/8" CDX plywood	—	SF	5.53	—	—	5.53
1/2" wallboard and 5/8" OSB sheathing	—	SF	4.86	—	—	4.86
5/8" wallboard and 1/2" CDX plywood	—	SF	4.81	—	—	4.81
5/8" wallboard and 1/2" OSB sheathing	—	SF	4.67	—	—	4.67
5/8" wallboard and 5/8" CDX plywood	—	SF	5.58	—	—	5.58
5/8" wallboard and 5/8" OSB sheathing	—	SF	4.90	—	—	4.90
2" x 6" studs 16" OC with gypsum wallboard on both sides						
1/2" wallboard	—	SF	2.66	—	—	2.66
5/8" wallboard	—	SF	2.71	—	—	2.71
2" x 6" studs 16" OC with gypsum wallboard inside and plywood or OSB outside						
1/2" wallboard and 1/2" CDX plywood	—	SF	4.21	—	—	4.21
1/2" wallboard and 1/2" OSB sheathing	—	SF	4.07	—	—	4.07
1/2" wallboard and 5/8" CDX plywood	—	SF	4.98	—	—	4.98
1/2" wallboard and 5/8" OSB sheathing	—	SF	4.30	—	—	4.30
5/8" wallboard and 1/2" CDX plywood	—	SF	4.26	—	—	4.26
5/8" wallboard and 1/2" OSB sheathing	—	SF	4.12	—	—	4.12
5/8" wallboard and 5/8" CDX plywood	—	SF	5.02	—	—	5.02
5/8" wallboard and 5/8" OSB sheathing	—	SF	4.35	—	—	4.35
Add to any of the above for the following, installed by panel fabricator:						
R-19 insulation	—	SF	1.56	—	—	1.56
R-13 insulation	—	SF	1.20	—	—	1.20
Vapor barrier	—	SF	.20	—	—	.20

06 Wood and Composites

	Craft@Hrs	Unit	Material	Labor	Equipment	Total
Door or window openings to 16 SF each	—	SF	3.54	—	—	3.54
Door or window openings over 16 SF each	—	SF	3.24	—	—	3.24
Electrical receptacles	—	Ea	80.60	—	—	80.60
Electrical switches	—	Ea	83.40	—	—	83.40
Labor and equipment cost to install panels						
Up to 8' high	F7@.003	SF	—	.15	.04	.19
Over 8' to 12' high	F7@.004	SF	—	.21	.06	.27

	Craft@Hrs	Unit	Material	Labor	Equipment	Total
Miscellaneous Rough Carpentry						
Furring, Utility Grade, unit costs incl. 5% allowance for waste and nails						
2" x 4" on masonry walls		C8@.024	LF	.86	1.14	2.00
1" x 4" machine nailed to ceiling		C8@.017	LF	.77	.81	1.58
1" x 4" nailed on concrete		C8@.016	LF	.77	.76	1.53
Skip sheathing, on roof rafters, machine nailed, #2 and Better, unit costs incl. 7% allowance for waste & nails						
1" x 6" at 9" centers (.67 BF per SF)						
Per SF of roof area		C8@.020	SF	1.70	.95	2.65
1" x 4" at 7" centers (.50 BF per SF)						
Per SF of roof area		C8@.030	SF	1.18	1.43	2.61
Particleboard, 4' x 8', used as underlayment, including 5% cutting waste.						
3/8" x 4' x 8' sheets		C8@.011	SF	.59	.52	1.11
1/2" x 4' x 8' sheets		C8@.011	SF	.75	.52	1.27
5/8" x 4' x 8' sheets		C8@.011	SF	.89	.52	1.41
3/4" x 4' x 8' sheets		C8@.011	SF	1.12	.52	1.64
Add for attaching to metal frame		C8@.005	SF	—	.24	.24
15 pound felt on walls		C8@.003	SF	.06	.14	.20
Super Jumbo Tex asphalt saturated Kraft (162 SF roll)		C8@.004	SF	.11	.19	.30

	Craft@Hrs	Unit	Material	Labor	Equipment	Total
Wood Trusses Material costs are for prefabricated wood trusses shipped to job site fully assembled ready for installation. Equipment is a 6,000 lb capacity fork lift. Labor includes unloading and handling and installing the trusses not over 20' above grade.						
Truss joists, TJI Type at 50 PSF load design, at 16" OC						
9-1/2" TJI/15	C8@.017	SF	4.64	.81	.44	5.89
11-7/8" TJI/15	C8@.017	SF	5.10	.81	.44	6.35
14" TJI/35	C8@.018	SF	7.17	.86	.47	8.50
16" TJI/35	C8@.018	SF	7.82	.86	.47	9.15
Add for job under 3,000 SF	C8@.004	SF	1.25	.19	.10	1.54
Roof trusses, 24" OC, any slope from 3 in 12 to 12 in 12, total height not to exceed 12' high from bottom chord to highest point on truss. Prices for trusses over 12' high will be up to 100% higher. Square foot (SF) costs, where shown, are per square foot of roof area to be covered.						
Scissor truss, 2" x 4" top and bottom chords						
Up to 38' span	F5@.022	SF	5.70	1.07	.23	7.00
40' to 50' span	F5@.028	SF	7.16	1.37	.29	8.82
Fink truss "W" (conventional roof truss), 2" x 4" top and bottom chords						
Up to 38' span	F5@.017	SF	4.93	.83	.18	5.94
40' to 50' span	F5@.022	SF	5.86	1.07	.23	7.16
Fink truss with 2" x 6" top and bottom chords						
Up to 38' span	F5@.020	SF	5.96	.98	.21	7.15
40' to 50' span	F5@.026	SF	7.17	1.27	.27	8.71
Fink truss with gable fill at 16" OC						
28' span, 5 in 12 slope	F5@.958	Ea	404.00	46.70	9.93	460.63
32' span, 5 in 12 slope	F5@1.26	Ea	499.00	61.50	13.10	573.60
40' span, 5 in 12 slope	F5@1.73	Ea	716.00	84.40	17.90	818.30

06 Wood and Composites

	Craft@Hrs	Unit	Material	Labor	Equipment	Total
Laminated Glued Beams (Glu-lam beams) Typical costs for horizontal micro-lam beams. Figures in parentheses show the approximate weight per linear foot of beam. Equipment cost is based on using a 4,000 lb capacity forklift with 30' lift.						
Steel connectors and shoes for laminated beams, including bolts,						
Typical per end or splice connection	—	Ea	157.00	—	—	157.00
Drill holes in laminated beams and attach connectors at grade before installing beam,						
based on number of holes in the connector, with work performed at job site						
Labor per each hole	F6@.236	Ea	—	11.70	—	11.70
Install beams with connections attached	F6@.150	LF	—	7.44	1.06	8.50
West Coast Douglas fir, 24F-V4, H=240 PSI, exterior glue, camber is 3,500' R for beams. Industrial grade, without wrap. For other grades see the adjustments that follow.						
3-1/8" x 6" (4.4 pounds per LF)	—	LF	7.94	—	—	7.94
3-1/8" x 9" (6.6 pounds per LF)	—	LF	12.50	—	—	12.50
3-1/8" x 10-1/2" (7.5 pounds per LF)	—	LF	13.60	—	—	13.60
3-1/8" x 12" (8.9 pounds per LF)	—	LF	15.70	—	—	15.70
3-1/8" x 15" (11.1 pounds per LF)	—	LF	19.20	—	—	19.20
3-1/8" x 18" (13.2 pounds per LF)	—	LF	23.20	—	—	23.20
5-1/8" x 6" (7.3 pounds per LF)	—	LF	11.40	—	—	11.40
5-1/8" x 9" (10.7 pounds per LF)	—	LF	17.10	—	—	17.10
5-1/8" x 12" (14.5 pounds per LF)	—	LF	23.00	—	—	23.00
5-1/8" x 15" (18.1 pounds per LF)	—	LF	28.50	—	—	28.50
5-1/8" x 18" (21.7 pounds per LF)	—	LF	34.10	—	—	34.10
5-1/8" x 21" (25.4 pounds per LF)	—	LF	39.80	—	—	39.80
5-1/8" x 24" (29.0 pounds per LF)	—	LF	45.30	—	—	45.30
6-3/4" x 12" (19.1 pounds per LF)	—	LF	30.10	—	—	30.10
6-3/4" x 15" (23.8 pounds per LF)	—	LF	37.90	—	—	37.90
6-3/4" x 18" (28.6 pounds per LF)	—	LF	45.50	—	—	45.50
6-3/4" x 21" (33.3 pounds per LF)	—	LF	53.20	—	—	53.20
6-3/4" x 24" (38.1 pounds per LF)	—	LF	61.00	—	—	61.00
Add to any of the beam costs shown in this section for:						
Industrial grade, clean, wrapped, add	—	%	12.5	—	—	—
Architectural grade, wrapped, add	—	%	20.0	—	—	—
One-coat rez-latex stain, add	—	%	10.0	—	—	—
Transportation to job site, per delivery,						
maximum 50 miles one way, add	—	LS	425.00	—	—	425.00
LVL beams (laminated veneer lumber). 1.75" x depth of beam. Usually in used in pairs. Use installation costs for glu-lam beams above. For installation, use actual length of beam for a 2-ply. Use 1.15 x length of beam for 3-ply and 1.25 x length of beam for 4-ply.						
1.75" x 9.25" 1.8E	—	LF	5.43	—	—	5.43
1.75" x 11.25" 1.8E	—	LF	6.64	—	—	6.64
1.75" x 11.875" 1.8E	—	LF	6.64	—	—	6.64
1.75" x 14" 1.8E	—	LF	8.84	—	—	8.84
1.75" x 16" 1.8E	—	LF	10.40	—	—	10.40
1.75" x 18" 1.8E	—	LF	11.30	—	—	11.30
1.75" x 20" 1.8E	—	LF	12.70	—	—	12.70
Stairs Job-built stairways, 3 stringers cut from 2" x 12" material, treads and risers from either 3/4" CDX plywood or 3/4" OSB sheathing.						
Material costs based on:						
2" x 12"	—	MBF	1,340.00	—	—	1,340.00
3/4" CDX plywood	—	MSF	1,530.00	—	—	1,530.00
3/4" OSB sheathing	—	MSF	1,900.00	—	—	1,900.00
1" x 6"	—	MSF	2,120.00	—	—	2,120.00
Plywood sheathing cost per 7-1/2" rise, 36" wide						
Straight run, 8'0" to 10'0" rise, per riser	C8@.530	Ea	23.80	25.20	—	49.00
"L"- or "U"-shape, per riser, add for landings	C8@.625	Ea	26.70	29.80	—	56.50

06 Wood and Composites

	Craft@Hrs	Unit	Material	Labor	Total
OSB sheathing cost per 7-1/2" rise, 36" wide					
Straight run, 8'0" to 10'0" rise, per riser	C8@.530	Ea	27.00	25.20	52.20
"L" - or "U"-shape, per riser, add for landings	C8@.625	Ea	29.90	29.80	59.70
Landings, framed and 3/4" CDX plywood surface					
Per SF of landing surface	C8@.270	SF	6.04	12.90	18.94
Landings, framed and 3/4" OSB sheathing surface					
Per SF of landing surface	C8@.270	SF	6.70	12.90	19.60
Factory cut and assembled straight closed box stairs, unfinished, 36" width					
Oak treads with 7-1/2" risers, price per riser					
3'0" to 3'6" wide, per riser	C8@.324	Ea	183.00	15.40	198.40
4'0" wide, per riser	C8@.357	Ea	223.00	17.00	240.00
Add for prefinished assembled stair rail with balusters and newel, per riser	C8@.257	Ea	80.50	12.20	92.70
Add for prefinished handrail, brackets and balusters	C8@.135	LF	25.80	6.43	32.23

07 Thermal and Moisture Protection

	Craft@Hrs	Unit	Material	Labor	Total
Dampproofing					
Asphalt wall primer, per coat, gallon covers 250 SF	CL@.010	SF	.03	.42	.45
Asphalt emulsion, wall, per coat, gallon covers 33 SF, brush on	CL@.013	SF	.25	.54	.79
Hot mop concrete wall, 2 coats and glass fabric	CL@.033	SF	1.44	1.37	2.81
Hot mop deck, 3 ply, felt, typical subcontract price	—	Sq	—	—	272.00
Hot mop deck, 4 ply, felt, typical subcontract price	—	Sq	—	—	319.00
Add for 1/2" asphalt fiberboard, subcontract price	—	Sq	—	—	116.00
Bituthene waterproofing membrane, 60 mil plain surface	CL@.025	SF	1.07	1.04	2.11
Waterproof baths in high rise	CL@.025	SF	2.60	1.04	3.64
Iron compound, internal coating, 2 coats	CL@.012	SF	2.47	.50	2.97
Roof vapor barrier, .004" polyethylene	CL@.002	SF	.09	.08	.17
Thermal Insulation					
Fiberglass batts, placed between or over framing members					
3-1/2" Kraft faced, R-11, between ceiling joists	A1@.006	SF	.49	.31	.80
3-1/2" Kraft faced, R-11, on suspended ceiling, working off ladders from below	A1@.018	SF	.49	.93	1.42
3-1/2" Kraft faced, R-11, in crawl space	A1@.020	SF	.49	1.03	1.52
3-1/2" Kraft faced, R-13, between ceiling joists	A1@.006	SF	.60	.31	.91
3-1/2" Kraft faced, R-13, on suspended ceiling, working off ladders from below	A1@.018	SF	.60	.93	1.53
3-1/2" Kraft faced, R-13, in crawl space	A1@.020	SF	.60	1.03	1.63
6-1/4" Kraft faced, R-19, between ceiling joists	A1@.006	SF	.78	.31	1.09
6-1/4" Kraft faced, R-19, on suspended ceiling, working off ladders from below	A1@.018	SF	.78	.93	1.71
6-1/4" Kraft faced, R-19, in crawl space	A1@.020	SF	.78	1.03	1.81
6-1/4" Kraft faced, R-19, between studs	A1@.006	SF	.78	.31	1.09
5-1/2" Kraft faced, R-21, between ceiling joists	A1@.006	SF	.98	.31	1.29
5-1/2" Kraft faced, R-21, on suspended ceiling, working off ladders from below	A1@.018	SF	.98	.93	1.91
5-1/2" Kraft faced, R-21, in crawl space	A1@.020	SF	.98	1.03	2.01
5-1/2" Kraft faced, R-21, between studs	A1@.006	SF	.98	.31	1.29
9-1/2" Kraft faced, R-30, between ceiling joists	A1@.006	SF	1.05	.31	1.36

07 Thermal and Moisture Protection

	Craft@Hrs	Unit	Material	Labor	Total
9-1/2" Kraft faced, R-30, on suspended ceiling, working off ladders from below	A1@.018	SF	1.05	.93	1.98
9-1/2" Kraft faced, R-30, in crawl space	A1@.020	SF	1.05	1.03	2.08
9-1/2" Kraft faced, R-30, between studs	A1@.006	SF	1.05	.31	1.36
12-1/4" Kraft faced, R-38, between ceiling joists	A1@.006	SF	1.50	.31	1.81
12-1/4" Kraft faced, R-38, on suspended ceiling, working off ladders from below	A1@.018	SF	1.50	.93	2.43
12-1/4" Kraft faced, R-38, in crawl space	A1@.020	SF	1.50	1.03	2.53
12-1/4" Kraft faced, R-38, between studs	A1@.006	SF	1.50	.31	1.81
Add for supporting batts on wire rods, 1 per SF	A1@.001	SF	.04	.05	.09
Add for foil one side	—	SF	.07	—	.07
Add for foil two sides	—	SF	.13	—	.13
Deduct for unfaced one side	—	SF	-.03	—	-.03
Add for Kraft paper two sides	—	SF	.04	—	.04
Fasteners for batts placed under a ceiling deck, including flat washers					
2-1/2" long	A1@.025	Ea	.26	1.29	1.55
4-1/2" long	A1@.025	Ea	.32	1.29	1.61
6-1/2" long	A1@.025	Ea	.44	1.29	1.73
Domed self-locking washers	A1@.005	Ea	.20	.26	.46
Blown fiberglass or mineral wool, over ceiling joists. Add blowing equipment cost at \$300 per day					
R-11, 5"	A1@.008	SF	.32	.41	.73
R-13, 6"	A1@.010	SF	.37	.52	.89
R-19, 9"	A1@.014	SF	.50	.72	1.22
Insulation board on walls, 4' x 8' Foamular® 150 polystyrene					
1/2" thick (R-2.5)	C8@.010	SF	.44	.48	.92
3/4" thick (R-3.8)	C8@.011	SF	.63	.52	1.15
1" thick (R-5.0)	C8@.011	SF	.65	.52	1.17
1-1/2" thick (R-7.5)	C8@.015	SF	.82	.71	1.53
2" thick (R-10)	C8@.015	SF	.99	.71	1.70
Expanded polystyrene board installed on perimeter walls					
1/2", R-3.3	C8@.010	SF	.43	.48	.91
3/4", R-2.9	C8@.010	SF	.28	.48	.76
1", R-4.20	C8@.011	SF	.55	.52	1.07
1", R-5.9	C8@.011	SF	.52	.52	1.04
1-1/2", R-5.9	C8@.015	SF	.43	.71	1.14
1-3/8", R-8.3	C8@.015	SF	.97	.71	1.68
2", R-8	C8@.015	SF	.46	.71	1.17
2", R-13	C8@.015	SF	1.12	.71	1.83
Polyisocyanurate foam core sheathing, Super Tuff-R®, foil face, painted back, 4' x 8' panels on perimeter walls					
1/2", R-3.3	C8@.010	SF	.45	.48	.93
3/4", R-5.5	C8@.010	SF	.50	.48	.98
1", R-6.5	C8@.011	SF	.80	.52	1.32
1-3/8", R-9.1	C8@.015	SF	1.06	.71	1.77
1-1/2", R-9.8	C8@.015	SF	.95	.71	1.66
2", R-13.0	C8@.015	SF	1.20	.71	1.91
Perlite or vermiculite, poured in concrete block cores					
Perlite only	—	CF	9.18	—	9.18
4" wall, 8.1 SF per CF	M1@.004	SF	1.13	.19	1.32
6" wall, 5.4 SF per CF	M1@.007	SF	1.70	.34	2.04
8" wall, 3.6 SF per CF	M1@.009	SF	2.55	.43	2.98
10" wall, 3.0 SF per CF	M1@.011	SF	3.06	.53	3.59
Poured vermiculite in wall cavities	M1@.032	CF	13.30	1.54	14.84
Sound board					
1/2", on walls	C8@.010	SF	1.17	.48	1.65
1/2", on floors	C8@.009	SF	1.17	.43	1.60

07 Thermal and Moisture Protection

	Craft@Hrs	Unit	Material	Labor	Total
Cold box insulation					
2" polystyrene	A1@.012	SF	.51	.62	1.13
1" cork	A1@.013	SF	5.50	.67	6.17
Add for overhead work or poor access areas	—	SF	—	.10	.10
Add for enclosed areas	—	SF	—	.10	.10
Add for 1 hour fire rating	—	SF	.31	—	.31

	Craft@Hrs	Unit	Material	Labor	Equipment	Total
2-Part Spray Applied Foam Insulation						
Open cell, 2-part sprayed foam, 1" thick	A1@2.00	CSF	16.40	103.00	1.13	120.53
Each add'l 1" thickness	A1@.050	CSF	16.40	2.58	.28	19.26
Closed cell, 2-part spray foam, 1" thick	A1@2.62	CSF	70.80	135.00	1.45	207.25
Each add'l 1" thickness	A1@.051	CSF	70.80	2.63	.28	73.71

	Craft@Hrs	Unit	Material	Labor	Total
Roof Insulation Roof insulation. Local regulation can affect the cost and availability of urethanes, isocyanurates, phenolics and polystyrene roof insulation board.					

Fiberglass board roof insulation					
3/4", R-2.80, C-0.36	R3@.570	Sq	117.00	26.90	143.90
1", R-4.20, C-0.24	R3@.636	Sq	139.00	30.00	169.00
1-3/8", R-5.30, C-0.19	R3@.684	Sq	179.00	32.30	211.30
1-5/8", R-6.70, C-0.15	R3@.706	Sq	202.00	33.30	235.30
2-1/4", R-8.30, C-0.12	R3@.797	Sq	249.00	37.60	286.60

Polystyrene rigid foam roof insulation. R-19 rating when used with batt insulation. Including 5% waste.					
1/2" 4' x 8' panels	R3@1.10	Sq	33.60	51.90	85.50
3/4" 4' x 8' panels	R3@1.10	Sq	38.30	51.90	90.20
1" 4' x 8' panels	R3@1.10	Sq	61.50	51.90	113.40
1-1/2" 4' x 8' panels	R3@1.10	Sq	84.00	51.90	135.90
2" 4' x 8' panels	R3@1.10	Sq	83.00	51.90	134.90

Expanded polystyrene board roof insulation					
3/4", R-5.30, C-0.19	R3@.478	Sq	38.30	22.50	60.80
1", R-6.70, C-0.15	R3@.478	Sq	32.80	22.50	55.30
1-1/2", R-11.1, C-0.09	R3@.570	Sq	84.00	26.90	110.90
2", R-14.3, C-0.07	R3@.684	Sq	83.00	32.30	115.30
2-1/4", R-16.7, C-0.06	R3@.684	Sq	102.00	32.30	134.30

Perlite board roof insulation					
1", R-2.80, C-0.36	R3@.639	Sq	125.00	30.10	155.10
1-1/2", R-4.20, C-0.24	R3@.728	Sq	183.00	34.30	217.30
2", R-5.30, C-0.19	R3@.820	Sq	225.00	38.70	263.70
2-1/2", R-6.70, C-0.15	R3@.956	Sq	281.00	45.10	326.10
3", R-8.30, C-0.12	R3@1.03	Sq	341.00	48.60	389.60
4", R-10.0, C-0.10	R3@1.23	Sq	451.00	58.00	509.00
5-1/4", R-14.3, C-0.07	R3@1.57	Sq	597.00	74.10	671.10

Cellular Foamglass (isocyanurates) board insulation, on roofs					
1-1/2"	R3@.775	Sq	455.00	36.60	491.60
Tapered 3/16" per foot	R3@.775	Sq	416.00	36.60	452.60

Polystyrene board roof insulation					
1", R-4.20, C-0.24, foil one side	R3@.545	Sq	44.80	25.70	70.50
1-1/2", R-5.9, C-0.16	R3@.639	Sq	44.70	30.10	74.80
2", R-8.30, C-0.12	R3@.797	Sq	49.90	37.60	87.50

Fasteners for board type insulation on roofs					
Typical 2-1/2" to 3-1/2" screws with 3" metal disks					
I-60	R3@.053	Sq	4.02	2.50	6.52
I-90	R3@.080	Sq	6.08	3.77	9.85
Add for plastic disks	—	Sq	1.01	—	1.01

07 Thermal and Moisture Protection

	Craft@Hrs	Unit	Material	Labor	Total
Exterior Wall Insulation and Finish System (EIFS) Polymer based exterior non-structural wall finish applied to concrete, masonry, stucco or exterior grade gypsum sheathing (such as Dryvit). System consists of a plaster base coat approximately 1/4" thick, and a glass fiber mesh embedded in the adhesive base coat. The base coat is applied over polystyrene insulation boards bonded to an existing flat vertical wall surface with adhesive. Costs shown are per SF of finished wall surface. These costs do not include surface preparation or wall costs. Add the cost of scaffolding if required. Add 50% to the labor costs when work is done from scaffolding.					
For scheduling purposes, estimate that a crew of three can field apply 250 SF of exterior wall insulation and finish systems in an 8-hour day.					
Adhesive mixture, 2 coats					
2.1 SF per SF of wall area including waste	F8@.021	SF	1.05	1.10	2.15
Glass fiber mesh					
1.1 SF per SF of wall area including waste	F8@.010	SF	.39	.52	.91
Insulation board, 1" thick, R-5.0					
1.05 SF per SF of wall area including waste	F8@.021	SF	.65	1.10	1.75
Textured finish coat, with integral color					
1.05 SF per SF of wall area including waste	F8@.038	SF	.83	1.98	2.81
Total with 1" thick insulation	F8@.090	SF	2.92	4.70	7.62
Add for 2" thick insulation board, R-10	—	SF	.34	—	.34
Add for 3" thick insulation board, R-15	—	SF	1.33	—	1.33
Add for 4" thick insulation board, R-20	—	SF	1.68	—	1.68
Aluminum Wall Cladding System, Exterior These costs assume installation by a manufacturer-trained contractor on a framed and insulated exterior building surface, including track system, panels and trim. Alply, Inc.					
Techwall solid aluminum panel, 1/8" thick, joints sealed with silicon sealer					
Kynar 500 paint finish	SM@.158	SF	24.60	9.68	34.28
Anodized aluminum finish	SM@.158	SF	24.70	9.68	34.38
Add for radius panels	SM@.032	SF	4.97	1.96	6.93
Cladding, Preformed Roofing and Siding Applied on metal framing.					
Architectural insulated metal panels with smooth .040 aluminum exterior face with Kynar 500 finish, 2" thick isocyanurate insulation, .040 mill finish aluminum interior sheet, shop applied extrusion and dry seal gasketed joint system, shop fabricated. Alply, Inc.					
Kynar 500 paint finish	SM@.136	SF	17.70	8.33	26.03
Add for radius panels	SM@.020	SF	2.54	1.23	3.77
Corrugated or ribbed roofing, colored galvanized steel, 9/16" deep, uninsulated					
18 gauge	SM@.026	SF	3.30	1.59	4.89
20 gauge	SM@.026	SF	2.87	1.59	4.46
22 gauge	SM@.026	SF	2.57	1.59	4.16
24 gauge	SM@.026	SF	2.19	1.59	3.78
Corrugated siding, colored galvanized steel, 9/16" deep, uninsulated					
18 gauge	SM@.034	SF	3.69	2.08	5.77
20 gauge	SM@.034	SF	3.20	2.08	5.28
22 gauge	SM@.034	SF	2.87	2.08	4.95
Ribbed siding, colored galvanized steel, 1-3/4" deep, box rib					
18 gauge	SM@.034	SF	3.87	2.08	5.95
20 gauge	SM@.034	SF	3.39	2.08	5.47
22 gauge	SM@.034	SF	2.98	2.08	5.06
Corrugated aluminum roofing, natural finish					
.020" aluminum	SM@.026	SF	1.99	1.59	3.58
.032" aluminum	SM@.026	SF	2.52	1.59	4.11
Add for factory painted finish	—	SF	.30	—	.30
Corrugated aluminum siding, natural finish					
.020" aluminum	SM@.034	SF	1.99	2.08	4.07
.032" aluminum	SM@.034	SF	2.46	2.08	4.54
Add for factory painted finish	—	SF	.30	—	.30

07 Thermal and Moisture Protection

	Craft@Hrs	Unit	Material	Labor	Total
Vinyl siding					
Solid vinyl, .042", horizontal siding	SM@.026	SF	.92	1.59	2.51
Add for insulated siding backer panel	SM@.001	SF	.42	.06	.48
Vinyl window and door trim	SM@.040	LF	.52	2.45	2.97
Vinyl siding and fascia system	SM@.032	SF	1.21	1.96	3.17
Laminated sandwich panel siding, enameled 22 gauge aluminum face one side, polystyrene core					
1" core	SM@.069	SF	5.82	4.23	10.05
1-1/2" core	SM@.069	SF	6.51	4.23	10.74
Membrane Roofing (One square "Sq" = 100 square feet)					
Built-up roofing, asphalt felt					
3-ply, smooth surface top sheet	R3@1.61	Sq	104.00	75.90	179.90
4-ply, base sheet, 3-ply felt, smooth surface top sheet	R3@1.85	Sq	127.00	87.30	214.30
5-ply, 20 year	R3@2.09	Sq	151.00	98.60	249.60
Built-up fiberglass felt roof					
Base and 3-ply felt	R3@1.93	Sq	138.00	91.00	229.00
Add for each additional ply	R3@.188	Sq	40.10	8.87	48.97
Add for light rock dress off (250 lbs per Sq)	R3@.448	Sq	20.80	21.10	41.90
Add for heavy rock dress off (400 lbs per Sq)	R3@.718	Sq	33.30	33.90	67.20
Remove and replace rock (400 lbs per Sq)					
Including new flood coat	R3@1.32	Sq	50.50	62.30	112.80
Aluminized coating for built-up roofing	R3@.599	Sq	36.60	28.30	64.90
Fire rated type	R3@.609	Sq	36.30	28.70	65.00
Modified APP, SBS flashing membrane	R3@.033	SF	.77	1.56	2.33
Cap sheet	R3@.277	Sq	57.70	13.10	70.80
Modified asphalt, APP, SBS base sheet and membrane	R3@1.97	Sq	176.00	92.90	268.90
Roll roofing					
90 lb mineral surface	R3@.399	Sq	50.00	18.80	68.80
19" wide selvage edge mineral surface (110 lb)	R3@.622	Sq	199.00	29.30	228.30
Double coverage selvage edge roll (140 lb)	R3@.703	Sq	216.00	33.20	249.20
Asphalt impregnated walkway for built-up roofing					
1/2"	R3@.016	SF	5.08	.75	5.83
3/4"	R3@.017	SF	6.42	.80	7.22
1"	R3@.020	SF	7.78	.94	8.72
Strip off existing 4-ply roof, no disposal included	R3@1.32	Sq	—	62.30	62.30
Elastomeric Roofing					
Butyl, general purpose rubber					
1/16"	R3@1.93	Sq	161.00	91.00	252.00
3/32"	R3@1.93	Sq	247.00	91.00	338.00
Neoprene, commercial grade, 1/16"	R3@2.23	Sq	413.00	105.00	518.00
Neoprene, commercial grade, 1/8"	R3@2.23	Sq	770.00	105.00	875.00
w/ adhesive	—	%	55.0	—	—
Neoprene, high strength, 1/16"	R3@2.23	Sq	553.00	105.00	658.00
Neoprene, high strength, 1/8"	R3@2.23	Sq	1,040.00	105.00	1,145.00
with adhesive	—	%	15.0	—	—
Neoprene, Mil R 6855 E, 1/16"	R3@2.23	Sq	288.00	105.00	393.00
Neoprene, Mil R 6855 E, 1/8"	R3@2.23	Sq	568.00	105.00	673.00
Acrylic-urethane foam roof system					
Remove gravel and prepare existing built-up roof	R3@1.26	Sq	6.42	59.40	65.82
Apply base and top coats of acrylic (.030")	R3@.750	Sq	140.00	35.40	175.40
Urethane foam 1" thick (R-7)	R3@.280	Sq	130.00	13.20	143.20
Urethane foam 2" thick (R-14)	R3@.500	Sq	218.00	23.60	241.60
Spray-on mineral granules, 40 lbs per CSF	R3@.600	Sq	21.10	28.30	49.40

07 Thermal and Moisture Protection

	Craft@Hrs	Unit	Material	Labor	Total
EPDM roofing system (Ethylene Propylene Diene Monomer)					
.045" loose laid membrane	R3@.743	Sq	95.00	35.00	130.00
.060" adhered membrane (excluding adhesive)	R3@1.05	Sq	154.00	49.50	203.50
.090" adhered membrane (excluding adhesive)	R3@1.30	Sq	203.00	61.30	264.30
Bonding adhesive	R3@.305	Sq	86.20	14.40	100.60
Lap splice cement, per 100 LF	R3@.223	CLF	31.80	10.50	42.30
Ballast rock, 3/4" to 1-1/2" gravel	R3@.520	Sq	14.00	24.50	38.50
Neoprene sheet flashing, .062"	R3@.021	SF	4.32	.99	5.31
Add for mechanical fasteners and washers					
6" long, 12" OC at laps	—	Ea	.98	—	.98
12" long, 12" OC at laps	—	Ea	1.94	—	1.94
Roof Re-coating (One square "Sq" = 100 square feet)					
Rubber roof coatings, for application over an existing low-slope single ply, built-up or metal roof.					
Roofing anti-bleed primer	—	Gal	36.50	—	36.50
Silicone roof coating	—	Gal	56.60	—	56.60
EPDM roof coating	—	Gal	45.80	—	45.80
Butyl (liquid) rubber roof coating	—	Gal	69.30	—	69.30
Polyester seam tape, 6" wide	—	CLF	23.50	—	23.50
Seam sealer	—	Gal	84.10	—	84.10
Roof preparation. Add the cost of disposal of debris and a pressure washer, if needed.					
Remove granules, ballast, debris (2.5 Sq per hour)	R3@.400	Sq	—	18.90	18.90
Sweep and pressure-wash (10 Sq per hour)	R3@.100	Sq	—	4.72	4.72
Wire brush metal flashing (50 LF per hour)	R3@.020	LF	—	.94	.94
Remove and replace roof sheathing,					
Per 4' x 8' x 1/2" panel	R3@2.00	Ea	23.20	94.30	117.50
Level depressions, to 3' diameter,					
Fill and finish each depression	R3@1.00	Ea	12.50	47.20	59.70
Level depressions, 3 to 6' diameter,					
Fill and finish each depression	R3@4.00	Ea	50.00	189.00	239.00
Patch voids and holes,					
poly mesh and two roof coats	R3@.083	Ea	1.50	3.92	5.42
Reinforce seams,					
poly mesh and seam sealer, 100 LF per gallon	R3@.013	LF	1.36	.61	1.97
Apply anti-bleed primer, 100 SF per gallon at 8 mils					
Brush (120 LF per manhour)	R3@.833	CLF	36.50	39.30	75.80
Roller (5 Sq per manhour)	R3@.200	Sq	36.50	9.43	45.93
Apply silicone roof coat, 50 SF per gallon, 2 coats totaling 22 mils					
Brush (60 LF per manhour)	R3@1.67	CLF	113.00	78.80	191.80
Roller (2 Sq per manhour)	R3@.500	Sq	113.00	23.60	136.60
Spray (4 Sq per manhour)	R3@.250	Sq	113.00	11.80	124.80
Deduct for single coat applications (11 mils)	—	%	-40.0	-33.0	—
Apply EPDM roof coat, 40 SF per gallon, single 20 mil coat					
Brush (100 LF per manhour)	R3@1.00	CLF	115.00	47.20	162.20
Squeegee and roller (3 Sq per manhour)	R3@.333	Sq	115.00	15.70	130.70
Spray (6 Sq per manhour)	R3@.142	Sq	115.00	6.70	121.70
Apply butyl roof coat, 45 SF per gallon, single 20 mil coat					
Brush (100 LF per manhour)	R3@1.00	CLF	154.00	47.20	201.20
Squeegee and roller (3 Sq per manhour)	R3@.333	Sq	154.00	15.70	169.70
Spray (6 Sq per manhour)	R3@.142	Sq	154.00	6.70	160.70
Add for polyester mesh overlay, (10 Sq per manhour)	R3@.100	Sq	23.50	4.72	28.22

07 Thermal and Moisture Protection

	Craft@Hrs	Unit	Material	Labor	Total
Cementitious Roofing System Tectum™ roof deck systems for use on open beam ceilings with exposed joists. Provides a nailable top surface, a core of Styrofoam brand insulation and an exposed interior Tectum™ ceiling plank substrate. Tectum™ roof deck is highly moisture resistant and possesses high compressive strength, excellent sound absorption, insulative properties and a finished interior. Costs shown include nails, screws, and adhesive. Includes normal cutting waste.					
Tectum I with T&G edges and square ends. Standard roof deck with foam insulation. Available in lengths up to 14' and widths to 3'					
2" thick	C8@.017	SF	3.68	.81	4.49
2-1/2" thick	C8@.019	SF	4.34	.90	5.24
3" thick	C8@.021	SF	4.97	1.00	5.97
Tectum III with T&G edges and square ends. Composite roof deck used where higher insulation values are required. Tectum III provides a finished interior surface, and foam insulation. Width is 47" and lengths are available from 4" to 16"					
3-1/2" thick	C8@.015	SF	8.36	.71	9.07
4" thick	C8@.021	SF	8.86	1.00	9.86
5" thick	C8@.027	SF	9.91	1.29	11.20
6" thick	C8@.033	SF	11.10	1.57	12.67
7" thick	C8@.039	SF	13.50	1.86	15.36
8" thick	C8@.045	SF	14.50	2.14	16.64
9" thick	C8@.051	SF	15.00	2.43	17.43
10" thick	C8@.057	SF	17.20	2.71	19.91
Cant Strips					
3" fiber	R3@.017	LF	.20	.80	1.00
6" fiber	R3@.017	LF	.42	.80	1.22
4" wood	R3@.017	LF	1.52	.80	2.32
6" wood	R3@.017	LF	1.54	.80	2.34
Flashing and Sheet Metal					
Prefinished sheet metal fascia and mansards, standing beam and batten					
Straight or simple	SM@.054	SF	4.90	3.31	8.21
Curved or complex	SM@.082	SF	7.40	5.02	12.42
Coping, gravel stop and flashing	SM@.037	LF	3.57	2.27	5.84
Sheet metal wainscot, galvanized	SM@.017	SF	.99	1.04	2.03
Aluminum flashing .032",					
Coping and wall cap, 16" girth	SM@.069	LF	4.23	4.23	8.46
Counter flash, 8"	SM@.054	LF	3.75	3.31	7.06
Reglet flashing, 8"	SM@.058	LF	1.55	3.55	5.10
Neoprene gasket for flashing	SM@.015	LF	1.36	.92	2.28
Gravel stop and fascia, 10"	SM@.084	LF	4.44	5.15	9.59
Side wall flashing, 9"	SM@.027	LF	2.32	1.65	3.97
Gravel stop					
4"	SM@.058	LF	5.04	3.55	8.59
6"	SM@.063	LF	5.71	3.86	9.57
8"	SM@.068	LF	6.92	4.17	11.09
12"	SM@.075	LF	11.50	4.59	16.09
Valley, 24"	SM@.070	LF	2.95	4.29	7.24
Copper flashing 16 oz,					
Roll 8" x 15'	SW@.750	Ea	230.00	31.90	261.90
Roof edging, 2" x 2" x 10'	SW@.350	Ea	128.00	14.90	142.90
Gravel stop					
4"	SM@.058	LF	26.20	3.55	29.75
6"	SM@.063	LF	30.30	3.86	34.16
8"	SM@.068	LF	35.40	4.17	39.57
10"	SM@.075	LF	43.40	4.59	47.99
Reglet flashing, 8"	SM@.054	LF	12.10	3.31	15.41
Neoprene gasket for flashing	SM@.015	LF	1.36	.92	2.28
Side wall flashing, 6"	SM@.027	LF	11.40	1.65	13.05
Base, 20 oz	SM@.072	LF	23.50	4.41	27.91
Valley, 24"	SM@.069	LF	21.30	4.23	25.53

07 Thermal and Moisture Protection

	Craft@Hrs	Unit	Material	Labor	Total
Sheet lead flashing					
Plumbing vents, soil stacks, 4 lbs per square foot					
4" pipe size	P6@.709	Ea	40.90	37.50	78.40
6" pipe size	P6@.709	Ea	47.40	37.50	84.90
8" pipe size	P6@.709	Ea	57.80	37.50	95.30
Roof drains, flat pan type, 36" x 36"					
2.5 lbs/SF material	P6@1.49	Ea	49.70	78.80	128.50
4 lbs/SF material	P6@1.49	Ea	83.90	78.80	162.70
6 lbs/SF material	P6@1.49	Ea	120.00	78.80	198.80
Stainless steel flashing					
Fascia roof edge, .018"	SM@.054	LF	4.26	3.31	7.57
Base, .018"	SM@.054	LF	5.14	3.31	8.45
Counter flash, .015"	SM@.054	LF	4.02	3.31	7.33
Valley, .015", 24"	SM@.069	LF	4.01	4.23	8.24
Reglets, .020", 8"	SM@.035	LF	3.50	2.14	5.64
Galvanized sheet metal flashing					
Cap and counter flash, 8"	SM@.046	LF	1.68	2.82	4.50
Coping and wall cap, 16" girth	SM@.069	LF	2.16	4.23	6.39
Gravel stop, 6"	SM@.060	LF	.65	3.68	4.33
Neoprene gasket	SM@.005	LF	1.36	.31	1.67
Pitch pockets, 24 gauge, filled					
4" x 4"	SM@.584	Ea	24.90	35.80	60.70
6" x 6"	SM@.584	Ea	31.50	35.80	67.30
8" x 8"	SM@.584	Ea	36.70	35.80	72.50
8" x 10"	SM@.777	Ea	58.40	47.60	106.00
8" x 12"	SM@.777	Ea	51.50	47.60	99.10
Reglet flashing, 8"	SM@.054	LF	1.61	3.31	4.92
Shingles (chimney flash)	RF@.064	LF	1.24	3.20	4.44
Side wall flashing, 9"	SM@.027	LF	1.20	1.65	2.85
"W" valley, 24"	SM@.069	LF	2.46	4.23	6.69
Plumbers counter flash cone, 4" diameter	P8@.204	Ea	7.80	9.54	17.34
Roof safes and caps					
4" galvanized sheet metal	SM@.277	Ea	15.90	17.00	32.90
4" aluminum	SM@.277	Ea	17.20	17.00	34.20
Pitch pockets, 16 oz copper, filled					
4" x 4"	SM@.547	Ea	163.00	33.50	196.50
6" x 6"	SM@.547	Ea	206.00	33.50	239.50
8" x 8"	SM@.547	Ea	245.00	33.50	278.50
8" x 10"	SM@.679	Ea	286.00	41.60	327.60
8" x 12"	SM@.679	Ea	791.00	41.60	832.60
Galvanized corner guards, 4" x 4"	SM@.039	LF	15.60	2.39	17.99
Copper sheet metal roofing, 16 oz					
Batten seam	SM@.065	SF	17.80	3.98	21.78
Standing seam	SM@.056	SF	20.50	3.43	23.93
Gutters and Downspouts					
Aluminum, .032", including hangers					
Fascia gutter, 5"	SM@.050	LF	1.05	3.06	4.11
Box gutter, 4"	SM@.050	LF	.96	3.06	4.02
Inside/Outside corner, for either of above	SM@.091	Ea	12.90	5.57	18.47
Dropouts, elbows, for either of above	SM@.101	Ea	13.10	6.19	19.29
Elbows, for either of above	SM@.101	Ea	4.19	6.19	10.38
Downspouts, to 24' height					
2" x 3"	SM@.037	LF	1.13	2.27	3.40
3" x 4"	SM@.047	LF	.25	2.88	3.13

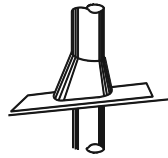

07 Thermal and Moisture Protection

	Craft@Hrs	Unit	Material	Labor	Total
4" diameter, round, 12' to 24' high	SM@.047	LF	1.74	2.88	4.62
Add for height over 24'	SM@.017	LF	—	1.04	1.04
Copper, K-style (ogee), 16 oz, including hangers. Add 25% for 20 oz. material.					
Box gutter, 5"	SM@.054	LF	11.20	3.31	14.51
Box gutter, 6"	SM@.058	LF	14.30	3.55	17.85
Box gutter, 8"	SM@.062	LF	36.20	3.80	40.00
Copper, K-style, highback, 16 oz, including hangers, Add 25% for 20 oz. material.					
Box gutter, 5"	SM@.054	LF	21.40	3.31	24.71
Box gutter, 6"	SM@.058	LF	27.80	3.55	31.35
Box gutter, 8"	SM@.062	LF	29.10	3.80	32.90
Half round gutter, single bead, 16 oz, including hangers, Add 25% for 20 oz. material.					
5" gutter	SM@.039	LF	10.20	2.39	12.59
6" gutter	SM@.051	LF	13.70	3.12	16.82
8" gutter	SM@.056	LF	24.90	3.43	28.33
Half round gutter, highback, 16 oz, including hangers, Add 25% for 20 oz. material.					
5" gutter	SM@.039	LF	22.20	2.39	24.59
6" gutter	SM@.051	LF	27.10	3.12	30.22
8" gutter	SM@.056	LF	29.90	3.43	33.33
Miter cuts					
K-style, 5"	SM@.154	Ea	23.50	9.43	32.93
K-style, 6"	SM@.160	Ea	36.90	9.80	46.70
K-style, 5", inside strip, 45 degrees	SM@.190	Ea	16.00	11.60	27.60
K-style, 5", inside strip, 90 degrees	SM@.190	Ea	11.20	11.60	22.80
K-style, 6", inside strip, 90 degrees	SM@.190	Ea	22.80	11.60	34.40
Highback, 5"	SM@.154	Ea	277.00	9.43	286.43
Highback, 6"	SM@.164	Ea	303.00	10.00	313.00
Highback, 8"	SM@.174	Ea	315.00	10.70	325.70
Half round, 5"	SM@.154	Ea	58.20	9.43	67.63
Half round, 6"	SM@.160	Ea	87.40	9.80	97.20
Half round, highback, 5"	SM@.174	Ea	254.00	10.70	264.70
Half round, highback, 6"	SM@.184	Ea	275.00	11.30	286.30
Half round, highback, 8"	SM@.194	Ea	287.00	11.90	298.90
Outlets					
K-style, rectangular	SM@.154	Ea	15.10	9.43	24.53
K-style, oval	SM@.160	Ea	7.12	9.80	16.92
Round, 3" dia	SM@.154	Ea	14.00	9.43	23.43
Round, 4" dia	SM@.174	Ea	16.70	10.70	27.40
Round, 5" dia	SM@.184	Ea	40.60	11.30	51.90
Round, 6" dia	SM@.194	Ea	51.70	11.90	63.60
Elbows					
Rectangular, 2" x 3"	SM@.154	Ea	14.50	9.43	23.93
Rectangular, 3" x 4"	SM@.160	Ea	20.80	9.80	30.60
Rectangular, 4" x 5"	SM@.180	Ea	54.40	11.00	65.40
Half round, "B" style, 3"	SM@.174	Ea	13.00	10.70	23.70
Half round, "B" style, 4"	SM@.184	Ea	19.10	11.30	30.40
Half round, "B" style, 5"	SM@.194	Ea	63.50	11.90	75.40
Half round, "B" style, 6"	SM@.204	Ea	103.00	12.50	115.50
Downspouts, to 24' height					
Rectangular, 2" x 3"	SM@.036	LF	12.60	2.21	14.81
Rectangular, 3" x 4"	SM@.047	LF	14.30	2.88	17.18
Rectangular, 4" x 5"	SM@.056	LF	30.70	3.43	34.13
Round, 3"	SM@.037	LF	11.30	2.27	13.57
Round, 4"	SM@.047	LF	15.60	2.88	18.48
Round, 5"	SM@.057	LF	22.20	3.49	25.69

07 Thermal and Moisture Protection

	Craft@Hrs	Unit	Material	Labor	Total
Round, 6"	SM@.067	LF	29.30	4.10	33.40
Add for heights over 24'	SM@.017	LF	—	1.04	1.04
Scuppers, copper, 16 oz, 8" x 8"	SM@.972	Ea	898.00	59.50	957.50
10" x 10"	SM@.972	Ea	1,090.00	59.50	1,149.50
Galvanized steel, 26 gauge, including hangers					
Box gutter 5"	SM@.054	LF	1.56	3.31	4.87
Dropouts, elbows	SM@.082	Ea	2.38	5.02	7.40
Fascia gutter					
5" face	SM@.054	LF	1.85	3.31	5.16
7" face	SM@.062	LF	2.46	3.80	6.26
Dropouts, elbows, for either of above	SM@.088	Ea	3.64	5.39	9.03
Downspouts, with all fittings, height to 24'					
2" x 3"	SM@.036	LF	1.32	2.21	3.53
3" x 4"	SM@.047	LF	2.00	2.88	4.88
3" round	SM@.037	LF	2.00	2.27	4.27
6" round	SM@.055	LF	1.88	3.37	5.25
Add for heights over 24'	SM@.017	LF	—	1.04	1.04
Roof sump, 18" x 18" x 5"	SM@.779	Ea	10.20	47.70	57.90
Scupper, 6" x 6" x 8"	SM@.591	Ea	30.70	36.20	66.90
Stainless steel, .015" thick, including hangers					
Box gutter, 5" wide, 4-1/2" high	SM@.054	LF	9.59	3.31	12.90
Dropouts, elbows	SM@.076	Ea	13.90	4.66	18.56
Downspout, 4" x 5", to 24' high	SM@.051	LF	8.53	3.12	11.65
Add for heights over 24'	SM@.017	LF	—	1.04	1.04
Vents, Louvers and Screens					
Fixed louvers, with screen, typical	SM@.402	SF	14.50	24.60	39.10
Door louvers, typical	SM@.875	Ea	31.10	53.60	84.70
Manual operating louvers, typical	SM@.187	SF	22.90	11.50	34.40
Cooling tower screens	SM@.168	SF	12.80	10.30	23.10
Bird screens with frame	SM@.028	SF	1.93	1.72	3.65
Concrete block vents, aluminum	M1@.370	SF	17.00	17.80	34.80
Frieze vents, with screen, 14" x 4"	C8@.198	Ea	3.52	9.42	12.94
Foundation vents, 6" x 14", ornamental	C8@.317	Ea	9.54	15.10	24.64
Attic vents, with louvers, 14" x 24"	C8@.377	Ea	27.90	17.90	45.80
Architectural facade screen, aluminum	SM@.187	SF	26.60	11.50	38.10
Add for enamel or light anodized	—	SF	2.83	—	2.83
Add for porcelain or heavy anodized	—	SF	6.87	—	6.87
Rain Dispersing Gutters Rustproof aluminum, installed on mounting brackets. Disperses rain into a 4 foot area. No downspouts needed. Resists clogging by leaves and debris. Rainhandler™					
Rain disperser	RF@.100	LF	5.90	4.99	10.89
Mounting brackets (use one each 18")	—	Ea	1.31	—	1.31
Horizontal adapter for roof edges that extend outward more than 2-1/2" from building (use one each 18")	RF@.020	Ea	2.64	1.00	3.64
Vertical adapter for vertical fascias, under 3" from building (use one each 5")	RF@.020	Ea	2.64	1.00	3.64
"Doorbrella" for installation above doors and windows	RF@.250	Ea	20.40	12.50	32.90
Drip edge extension for roof edges that extend less than 1-1/2" from vertical fascia (use one each 18")	RF@.020	Ea	5.32	1.00	6.32
Roof valley rain diverter	RF@.050	Ea	8.03	2.50	10.53
Fascia adapter for angled fascia boards	RF@.050	Ea	2.64	2.50	5.14

07 Thermal and Moisture Protection

	Craft@Hrs	Unit	Material	Labor	Total
Roof Accessories					
Roof hatches, steel, not including ladder					
30" x 30"	C8@3.09	Ea	565.00	147.00	712.00
30" x 72"	C8@4.69	Ea	1,360.00	223.00	1,583.00
36" x 36"	C8@3.09	Ea	645.00	147.00	792.00
36" x 72"	C8@4.69	Ea	1,450.00	223.00	1,673.00
Ceiling access hatches					
30" x 30"	C8@1.59	Ea	340.00	75.70	415.70
42" x 42"	C8@1.89	Ea	407.00	90.00	497.00
Smoke vents					
Aluminum, 48" x 48"	C8@3.09	Ea	1,610.00	147.00	1,757.00
Galvanized, 48" x 48"	C8@3.09	Ea	1,410.00	147.00	1,557.00
Fusible "shrink-out" heat and smoke vent (PVC dome in aluminum frame)					
4' x 8'	C8@5.15	Ea	1,290.00	245.00	1,535.00
Roof scuttle, aluminum, 2'6" x 3'0"	C8@3.50	Ea	633.00	167.00	800.00
Ventilators					
Rotary, wind driven					
6" diameter	SM@.913	Ea	85.00	55.90	140.90
12" diameter	SM@.913	Ea	104.00	55.90	159.90
24" diameter	SM@1.36	Ea	294.00	83.30	377.30
Ventilators, mushroom type, motorized, single speed, including damper and bird screen but no electrical work					
8", 180 CFM	SM@2.93	Ea	381.00	179.00	560.00
12", 1,360 CFM	SM@2.93	Ea	632.00	179.00	811.00
18", 2,000 CFM	SM@4.00	Ea	902.00	245.00	1,147.00
24", 4,000 CFM	SM@4.86	Ea	1,380.00	298.00	1,678.00
Add for two-speed motor	—	%	35.0	—	—
Add for explosive proof units	—	Ea	521.00	—	521.00
Windstorm Certified Roof Turbine Fans Complies with ASHRAE/American National Standards Institute specification 62.2-2007 and Air Conditioning Contractors of America standard ACCA 5QI-2007, "HVAC Indoor Air Quality Installation Specification 2007." U.S. Green Building Council and Underwriters Laboratory approved. Texas Department of Insurance report # RV-12. Air Vent, Empire, Lomanco or equal.					
12" dia., galvanized steel	R1@2.50	Ea	279.00	90.60	369.60
14" dia., galvanized steel	R1@4.50	Ea	435.00	163.00	598.00
12" dia., high-impact polypropylene	R1@7.00	Ea	645.00	254.00	899.00
14" dia., high-impact polypropylene	R1@7.50	Ea	847.00	272.00	1,119.00
Add for duct hangers	R1@.250	Ea	3.90	9.06	12.96
Add for sheet metal duct	R1@.350	LF	6.17	12.70	18.87
Add for edge flashing sealant	R1@.150	LF	2.88	5.43	8.31

Cast-in-Place Concrete Fireproofing Costs per linear foot (LF) of steel beam, column or girder. Use these figures to estimate the cubic feet (CF) of concrete per linear foot and square feet (SF) of form required per linear foot for each type of beam, column or girder. Quantities include concrete required to fill the void between the web and flange and provide 2" protection at the flanges. A small change in concrete thickness at flanges has very little effect on cost. Use \$7,500.00 as a minimum job cost for work of this type. Concrete thickness for fireproofing will usually be:

Members at least 6" x 6" but less than 8" x 8" — 3" for a 4 hour rating, 2" for a 3 hour rating, 1-1/2" for a 2 hour rating, and 1" for a 1 hour rating.

Members at least 8" x 8" but less than 12" x 12" — 2-1/2" for a 4 hour rating, 2" for a 3 hour rating, 1" for a 1 or 2 hour rating.

Members 12" x 12" or greater — 2" for a 4 hour rating and 1" for a 1, 2, or 3 hour rating.

Labor costs include the time needed to prepare formwork sketches at the job site, measure for the forms, fabricate, erect, align and brace the forms, cut, bend, place and tie the reinforcing steel, install embedded steel items, place and finish the concrete and strip, clean and stack the forms. Labor costs assume a concrete forming, placing and finishing crew of 1 carpenter, 1 laborer and 1 cement finisher. Concrete placing equipment assumes the use of a concrete pump.

07 Thermal and Moisture Protection

Craft@Hrs Unit Material Labor Equipment Total

For scheduling purposes, estimate that a crew of 3 will fireproof the following quantities of steel in an 8-hour day:

15 LF of W21 through W36 members,
25 LF of W8 through W18 members, 22 LF of S12 through S24 members, and 42 LF of M4 through W6 or S6 through S8 members.

Material costs assume reinforcing steel is #3 and #4 bars at 12" on center each way and includes waste and laps. Form cost assumes 3 uses without completely disassembling the form. Normal cleaning and repairs are included. No salvage value is assumed. Cost for forms, before allowance for waste, is based on Standard & Better lumber and 3/4" plyform.

Concrete and accessories for fireproofing

Concrete, 3,000 PSI pump mix with 5% allowance for waste including pump cost	P9@.600	CY	184.00	29.40	10.50	223.90
Grade A60 reinforcing bars, set and tied, with 50 lbs per CY of concrete	P9@.790	CY	37.30	38.70	—	76.00
Hangers, snap-ties, misc. embedded steel with 10 lb per CY of concrete	P9@.660	CY	66.80	32.30	—	99.10
Concrete test cylinders including test reports, with 5 per 100 CY	—	CY	1.25	—	—	1.25
Total for concrete and accessories	P9@2.05	CY	289.35	100.40	10.50	400.25

Forms for concrete fireproofing These costs assume the following materials are used per square foot of contact area (SFCA): Nails, clamps and form oil costing \$.25 per board foot of lumber, 1.2 SF of 3/4" plyform and 3.7 BF of lumber per SFCA.

Make, erect, align and strip forms, 3 uses	P9@.150	SF	4.20	7.35	—	11.55
Sack and patch concrete SF	P9@.010	SF	.18	.49	—	.67
Total for forms and finishing, per use	P9@.160	SF	4.38	7.84	—	12.22

Sample fireproofing estimate for ten W24 x 55 beams 20' long. Note from the table below that this beam requires 2.7 cubic feet of concrete per linear foot and 6.9 square feet of form per linear foot. Using labor and material prices from above to estimate 200 linear feet of beam. (Total costs have been rounded)

Concrete (200 × 2.7 = 540 CF or 20 CY)	P9@41.0	LS	5,780.00	2,010.00	716.00	8,506.00
Form and finish (200 × 6.9 = 1,380 SF)	P9@221	LS	6,050.00	10,800.00	—	16,850.00
Total job cost shown above	P9@262	LS	11,830.00	12,810.00	716.00	25,356.00
Cost per linear foot of beam	P9@1.31	LF	59.15	64.05	3.58	126.78

Cast-in-place concrete fireproofing Cost per LF, including concrete and forming.

W36 x 135 to W36 x 300 5.13 CF and 10.07 SF per LF	P9@2.00	LF	99.10	98.00	1.99	199.09
W33 x 118 to W30 x 241 4.59 CF and 9.35 SF per LF	P9@1.84	LF	90.10	90.20	1.78	182.08
W30 x 99 to W30 x 211 3.78 CF and 8.4 SF per LF	P9@1.63	LF	77.30	79.90	1.47	158.67
W27 x 84 to W27 x 178 3.51 CF and 8.19 SF per LF	P9@1.57	LF	73.50	76.90	1.36	151.76
W24 x 55 to W24 x 162 2.7 CF and 6.9 SF per LF	P9@1.31	LF	59.20	64.20	1.05	124.45
W21 x 44 to W21 x 147 2.43 CF and 6.75 SF per LF	P9@1.26	LF	55.60	61.80	.94	118.34
W18 x 37 to W18 x 71 1.62 CF and 5.34 SF per LF	P9@.974	LF	40.80	47.70	.63	89.13
W16 x 26 to W16 x 100 1.62 CF and 5.4 SF per LF	P9@.987	LF	41.00	48.40	.63	90.03

07 Thermal and Moisture Protection

	Craft@Hrs	Unit	Material	Labor	Equipment	Total
W14 x 90 to W14 x 730 2.97 CF and 7.15 SF per LF	P9@1.37	LF	63.10	67.10	1.15	131.35
W14 x 22 to W14 x 82 1.35 CF and 4.7 SF per LF	P9@.854	LF	35.10	41.90	.52	77.52
W12 x 65 to W12 x 336 2.16 CF and 6.08 SF per LF	P9@1.13	LF	49.80	55.40	.84	106.04
W12 x 40 to W12 x 58 1.62 CF and 5.4 SF per LF	P9@.987	LF	41.00	48.40	.63	90.03
W12 x 14 to W12 x 35 1.08 CF and 4.44 SF per LF	P9@.790	LF	31.00	38.70	.42	70.12
W10 x 33 to W10 x 112 1.35 CF and 4.75 SF per LF	P9@.862	LF	35.30	42.20	.52	78.02
W10 x 12 to W10 x 30 1.08 CF and 4.56 SF per LF	P9@.808	LF	31.60	39.60	.42	71.62
W8 x 24 to W8 x 67 1.08 CF and 4.4 SF per LF	P9@.784	LF	30.90	38.40	.42	69.72
W8 x 10 to W8 x 21 0.81 CF and 3.87 SF per LF	P9@.678	LF	25.60	33.20	.31	59.11
W6 x 15 to W6 x 25 0.81 CF and 3.84 SF per LF	P9@.672	LF	25.50	32.90	.31	58.71
W6 x 9 to W6 x 16 0.54 CF and 2.92 SF per LF	P9@.507	LF	18.60	24.80	.21	43.61
W5 x 16 to W5 x 19 0.54 CF and 2.86 SF per LF	P9@.499	LF	18.30	24.50	.21	43.01
W4 x 13 0.54 CF and 3.2 SF per LF	P9@.552	LF	19.80	27.10	.21	47.11
M4 x 13 to M14 x 18 0.54 CF and 2.9 SF per LF	P9@.504	LF	18.50	24.70	.21	43.41
S24 x 80 to S24 x 121 2.43 CF and 7.11 SF per LF	P9@1.32	LF	57.20	64.70	.94	122.84
S20 x 66 to S20 x 96 1.89 CF and 6.09 SF per LF	P9@1.12	LF	46.90	54.90	.73	102.53
S15 x 43 to S18 x 70 1.62 CF and 5.82 SF per LF	P9@1.05	LF	42.90	51.50	.63	95.03
S12 x 35 to S12 x 50 1.08 CF and 4.44 SF per LF	P9@.790	LF	31.00	38.70	.42	70.12
S8 x 23 to S10 x 35 0.81 CF and 3.81 SF per LF	P9@.670	LF	25.40	32.80	.31	58.51
S6 x 13 to S7 x 20 0.54 CF and 2.91 SF per LF	P9@.504	LF	18.50	24.70	.21	43.41

Spray-Applied Fireproofing, Subcontract Fire endurance coating made from inorganic vermiculite and Portland cement. Costs assume a 10,000 board foot job. (One BF is one square foot covered 1" thick.) For smaller jobs, increase the cost by 5% for each 500 BF less than 10,000 BF. Use \$2,000 as a minimum subcontract price. For thickness other than 1", adjust these costs proportionately. For scheduling purposes, estimate that a crew of 2 plasterers and 1 helper can apply 200 to 250 board feet per hour.

	Craft@Hrs	Unit	Material	Labor	Total
Structural steel columns	—	BF	—	—	2.66
Structural steel beams	—	BF	—	—	2.37
Purlins, girts, and miscellaneous members	—	BF	—	—	2.18
Decks, ceilings or walls	—	BF	—	—	2.01
Add for 18 gauge 2" hex mesh reinforcing	—	BF	—	—	.53
Add for key coat bonded on primed surfaces	—	SF	—	—	.55

07 Thermal and Moisture Protection

Beams and Columns	Beams	Cost LF	Columns	Cost LF
Rule-of-thumb method for estimating spray-applied fireproofing on bare structural steel by member size:				
W36 x 135 to 300	10 BF/LF	23.70	11 BF/LF	29.20
W33 x 118 to 241	9 BF/LF	21.30	10 BF/LF	26.60
W30 x 99 to 211	8 BF/LF	19.00	9 BF/LF	23.90
W27 x 84 to 178	7 BF/LF	16.60	8 BF/LF	21.30
W24 x 55 to 182	6.5 BF/LF	15.40	7.5 BF/LF	19.90
W21 x 44 to 147	6 BF/LF	14.20	7 BF/LF	18.60
W18 x 35 to 118	5 BF/LF	11.90	6 BF/LF	15.90
W16 x 28 to 57	3.5 BF/LF	8.29	4.5 BF/LF	12.00
W14 x 61 to 132	5.5 BF/LF	13.00	6.5 BF/LF	17.30
W14 x 22 to 63	4 BF/LF	9.48	5 BF/LF	13.30
W12 x 65 to 190	5 BF/LF	11.90	6 BF/LF	15.90
W12 x 40 to 58	4 BF/LF	9.48	5 BF/LF	13.30
W12 x 14 to 35	3 BF/LF	7.11	4 BF/LF	10.60
W10 x 49 to 112	4 BF/LF	9.48	5 BF/LF	13.30
W10 x 22 to 45	3 BF/LF	7.11	4 BF/LF	10.60
W10 x 12 to 19	2 BF/LF	4.74	3 BF/LF	7.97
W8 x 24 to 67	3 BF/LF	7.11	4 BF/LF	10.60
W6 x 9 to 25	2 BF/LF	4.74	3 BF/LF	7.97
W5 x 16 to 19	2 BF/LF	4.74	2.5 BF/LF	6.64
W4 x 13	1 BF/LF	2.37	2 BF/LF	5.31

Purlins and Girts	Purlins or Girts	Cost LF
MC 18 members	4 BF/LF	8.73
MC 10 to MC 13 members	3 BF/LF	6.55
MC 8 members	2 BF/LF	4.37
C 10 to C 15 members	3 BF/LF	6.55
C 7 to C 9 members	2 BF/LF	4.37

Sealants and Caulking By joint size. Costs assume 10% waste. Twelve 10.5 ounce cartridges equal one gallon and yield 231 cubic inches of caulk or sealant. Productivity shown assumes one roofer using a bulk dispenser. Add the cost of joint cleaning, if required.

	Craft@Hrs	Unit	Material	Labor	Total
Silicone latex caulk					
1/4" x 1/4", 351 LF/gallon, 63 LF per hour	RF@.016	LF	.02	.80	.82
1/4" x 3/8", 234 LF/gallon, 60 LF per hour	RF@.017	LF	.03	.85	.88
1/4" x 1/2", 176 LF/gallon, 58 LF per hour	RF@.017	LF	.05	.85	.90
3/8" x 3/8", 156 LF/gallon, 58 LF per hour	RF@.017	LF	.05	.85	.90
3/8" x 1/2", 117 LF/gallon, 57 LF per hour	RF@.017	LF	.07	.85	.92
3/8" x 5/8", 94 LF/gallon, 56 LF per hour	RF@.018	LF	.09	.90	.99
3/8" x 3/4", 76 LF/gallon, 52 LF per hour	RF@.019	LF	.11	.95	1.06
1/2" x 1/2", 87 LF/gallon, 56 LF per hour	RF@.018	LF	.09	.90	.99
1/2" x 5/8", 70 LF/gallon, 50 LF per hour	RF@.020	LF	.12	1.00	1.12
1/2" x 3/4", 58 LF/gallon, 48 LF per hour	RF@.021	LF	.14	1.05	1.19
1/2" x 7/8", 51 LF/gallon, 46 LF per hour	RF@.022	LF	.16	1.10	1.26
1/2" x 1", 44 LF/gallon, 45 LF per hour	RF@.022	LF	.18	1.10	1.28
3/4" x 3/4", 39 LF/gallon, 44 LF per hour	RF@.023	LF	.21	1.15	1.36
1" x 1", 22 LF/gallon, 30 LF per hour	RF@.033	LF	.37	1.65	2.02
Acrylic latex plus silicone caulk					
1/4" x 1/4", 351 LF/gallon, 63 LF per hour	RF@.016	LF	.10	.80	.90
1/4" x 3/8", 234 LF/gallon, 60 LF per hour	RF@.017	LF	.15	.85	1.00
1/4" x 1/2", 176 LF/gallon, 58 LF per hour	RF@.017	LF	.21	.85	1.06

07 Thermal and Moisture Protection

	Craft@Hrs	Unit	Material	Labor	Total
3/8" x 3/8", 156 LF/gallon, 58 LF per hour	RF@.017	LF	.23	.85	1.08
3/8" x 1/2", 117 LF/gallon, 57 LF per hour	RF@.017	LF	.31	.85	1.16
3/8" x 5/8", 94 LF/gallon, 56 LF per hour	RF@.018	LF	.39	.90	1.29
3/8" x 3/4", 76 LF/gallon, 52 LF per hour	RF@.019	LF	.48	.95	1.43
1/2" x 1/2", 87 LF/gallon, 56 LF per hour	RF@.018	LF	.42	.90	1.32
1/2" x 5/8", 70 LF/gallon, 50 LF per hour	RF@.020	LF	.52	1.00	1.52
1/2" x 3/4", 58 LF/gallon, 48 LF per hour	RF@.021	LF	.63	1.05	1.68
1/2" x 7/8", 51 LF/gallon, 46 LF per hour	RF@.022	LF	.71	1.10	1.81
1/2" x 1", 44 LF/gallon, 45 LF per hour	RF@.022	LF	.82	1.10	1.92
3/4" x 3/4", 39 LF/gallon, 44 LF per hour	RF@.023	LF	.93	1.15	2.08
1" x 1", 22 LF/gallon, 30 LF per hour	RF@.033	LF	1.65	1.65	3.30
100 percent silicone caulk					
1/4" x 1/4", 351 LF/gallon, 63 LF per hour	RF@.016	LF	.36	.80	1.16
1/4" x 3/8", 234 LF/gallon, 60 LF per hour	RF@.017	LF	.55	.85	1.40
1/4" x 1/2", 176 LF/gallon, 58 LF per hour	RF@.017	LF	.72	.85	1.57
3/8" x 3/8", 156 LF/gallon, 58 LF per hour	RF@.017	LF	.82	.85	1.67
3/8" x 1/2", 117 LF/gallon, 57 LF per hour	RF@.017	LF	1.09	.85	1.94
3/8" x 5/8", 94 LF/gallon, 56 LF per hour	RF@.018	LF	1.36	.90	2.26
3/8" x 3/4", 76 LF/gallon, 52 LF per hour	RF@.019	LF	1.68	.95	2.63
1/2" x 1/2", 87 LF/gallon, 56 LF per hour	RF@.018	LF	1.47	.90	2.37
1/2" x 5/8", 70 LF/gallon, 50 LF per hour	RF@.020	LF	1.82	1.00	2.82
1/2" x 3/4", 58 LF/gallon, 48 LF per hour	RF@.021	LF	2.20	1.05	3.25
1/2" x 7/8", 51 LF/gallon, 46 LF per hour	RF@.022	LF	2.50	1.10	3.60
1/2" x 1", 44 LF/gallon, 45 LF per hour	RF@.022	LF	2.90	1.10	4.00
3/4" x 3/4", 39 LF/gallon, 44 LF per hour	RF@.023	LF	3.27	1.15	4.42
1" x 1", 22 LF/gallon, 30 LF per hour	RF@.033	LF	5.80	1.65	7.45
Polyurethane sealant					
1/4" x 1/4", 351 LF/gallon, 63 LF per hour	RF@.016	LF	.26	.80	1.06
1/4" x 3/8", 234 LF/gallon, 60 LF per hour	RF@.017	LF	.39	.85	1.24
1/4" x 1/2", 176 LF/gallon, 58 LF per hour	RF@.017	LF	.52	.85	1.37
3/8" x 3/8", 156 LF/gallon, 58 LF per hour	RF@.017	LF	.59	.85	1.44
3/8" x 1/2", 117 LF/gallon, 57 LF per hour	RF@.017	LF	.79	.85	1.64
3/8" x 5/8", 94 LF/gallon, 56 LF per hour	RF@.018	LF	.98	.90	1.88
3/8" x 3/4", 76 LF/gallon, 52 LF per hour	RF@.019	LF	1.21	.95	2.16
1/2" x 1/2", 87 LF/gallon, 56 LF per hour	RF@.018	LF	1.06	.90	1.96
1/2" x 5/8", 70 LF/gallon, 50 LF per hour	RF@.020	LF	1.31	1.00	2.31
1/2" x 3/4", 58 LF/gallon, 48 LF per hour	RF@.021	LF	1.59	1.05	2.64
1/2" x 7/8", 51 LF/gallon, 46 LF per hour	RF@.022	LF	1.80	1.10	2.90
1/2" x 1", 44 LF/gallon, 45 LF per hour	RF@.022	LF	2.09	1.10	3.19
3/4" x 3/4", 39 LF/gallon, 44 LF per hour	RF@.023	LF	2.36	1.15	3.51
1" x 1", 22 LF/gallon, 30 LF per hour	RF@.033	LF	4.18	1.65	5.83
Backing rods for sealant					
Closed cell, 1/4" rod	RF@.010	LF	.04	.50	.54
Closed cell, 3/8" rod	RF@.011	LF	.10	.55	.65
Closed cell, 1/2" rod	RF@.011	LF	.14	.55	.69
Closed cell, 5/8" rod	RF@.012	LF	.12	.60	.72
Closed cell, 3/4" rod	RF@.012	LF	.23	.60	.83
Closed cell, 1" rod	RF@.013	LF	.51	.65	1.16
Closed cell, 1-1/4" rod	RF@.014	LF	.35	.70	1.05
Closed cell, 1-1/2" rod	RF@.015	LF	.38	.75	1.13
Closed cell, 2" rod	RF@.015	LF	.75	.75	1.50
Closed cell, 3" rod	RF@.018	LF	1.89	.90	2.79

07 Thermal and Moisture Protection

	Craft@Hrs	Unit	Material	Labor	Total
Expansion Joints, Preformed					
Wall and ceiling, aluminum cover					
Drywall or panel type	CC@.067	LF	17.10	3.59	20.69
Plaster type	CC@.067	LF	17.10	3.59	20.69
Floor to wall, 3" x 3"	CC@.038	LF	9.27	2.03	11.30
Floor, 3"	CC@.038	LF	11.70	2.03	13.73
Neoprene joint with aluminum cover	CC@.079	LF	24.70	4.23	28.93
Wall to roof joint	CC@.094	LF	9.96	5.03	14.99
Bellows type expansion joints, butyl with neoprene backer					
16 oz copper, 4" wide	CC@.046	LF	18.90	2.46	21.36
28 gauge stainless steel, 4" wide	CC@.046	LF	14.80	2.46	17.26
26 gauge galvanized sheet metal, 4" wide	CC@.046	LF	9.91	2.46	12.37
16 oz copper, 6" wide	CC@.046	LF	21.50	2.46	23.96
28 gauge stainless steel, 6" wide	CC@.046	LF	17.30	2.46	19.76
26 gauge galvanized sheet metal, 6" wide	CC@.046	LF	11.90	2.46	14.36
Neoprene gaskets, closed cell					
1/8" x 2"	CC@.019	LF	1.01	1.02	2.03
1/8" x 6"	CC@.023	LF	2.36	1.23	3.59
1/4" x 2"	CC@.022	LF	1.18	1.18	2.36
1/4" x 6"	CC@.024	LF	2.49	1.28	3.77
1/2" x 6"	CC@.025	LF	3.72	1.34	5.06
1/2" x 8"	CC@.028	LF	5.48	1.50	6.98
Acoustical caulking, drywall or plaster type	CC@.038	LF	.40	2.03	2.43
Polyisobutylene tapes, non-drying					
Polybutene	CC@.028	LF	.37	1.50	1.87
Polyisobutylene/butyl, preformed	CC@.020	LF	.20	1.07	1.27
Expansion Joint Covers					
Surface type, aluminum					
Floor, 1-1/2"	CC@.194	LF	32.00	10.40	42.40
Wall and ceiling, 1-1/2"	CC@.185	LF	18.00	9.90	27.90
Gymnasium base	CC@.099	LF	14.80	5.30	20.10
Roof, typical	CC@.145	LF	30.80	7.76	38.56

08 Openings

Complete Hollow Metal Door Assembly These figures show the costs normally associated with installing an exterior hollow core steel door.

Hollow metal exterior 3' x 7' flush door, with frame, hardware and trim, complete

Stock hollow metal flush door,					
16 gauge, 3' x 7' x 1-3/4", non-rated	C8@.721	Ea	560.00	34.30	594.30
Closer plate reinforcing on door	—	Ea	22.00	—	22.00
Stock 18 gauge frame, 6" jamb, non-rated	C8@.944	Ea	170.00	44.90	214.90
Closer plate on frame	—	Ea	8.44	—	8.44
Three hinges, 4-1/2" x 4-1/2"	C8@.578	LS	141.00	27.50	168.50
Lockset, mortise type	C8@.949	Ea	373.00	45.20	418.20
Saddle type threshold, aluminum, 3'	C8@.276	Ea	27.40	13.10	40.50
Standard duty closer	C8@.787	Ea	161.00	37.50	198.50
Weatherstripping, bronze and neoprene	C8@2.58	LS	72.80	123.00	195.80
Paint with primer and 2 coats enamel	C8@.781	LS	16.40	37.20	53.60
Total cost door, frame and trim as described above	C8@7.62	Ea	1,552.04	362.70	1,914.74

08 Openings

	Craft@Hrs	Unit	Material	Labor	Total
Hollow Metal Exterior Doors Commercial quality doors.					
These costs do not include the frame, hinges, lockset, trim or finishing.					
6'8" high hollow flush doors, 1-3/8" thick, non-rated					
2'6" wide, 20 gauge	C8@.681	Ea	317.00	32.40	349.40
2'8" wide, 20 gauge	C8@.683	Ea	328.00	32.50	360.50
3'0" wide, 20 gauge	C8@.721	Ea	349.00	34.30	383.30
6'8" high hollow flush doors, 1-3/4" thick, non-rated					
2'6" wide, 20 gauge	C8@.681	Ea	386.00	32.40	418.40
2'8" wide, 20 gauge	C8@.697	Ea	394.00	33.20	427.20
2'8" wide, 18 gauge	C8@.697	Ea	461.00	33.20	494.20
2'8" wide, 16 gauge	C8@.697	Ea	536.00	33.20	569.20
3'0" wide, 20 gauge	C8@.721	Ea	417.00	34.30	451.30
3'0" wide, 18 gauge	C8@.721	Ea	481.00	34.30	515.30
3'0" wide, 16 gauge	C8@.721	Ea	560.00	34.30	594.30
7'0" high hollow flush doors, 1-3/4" thick, non-rated					
2'6" or 2'8" wide, 20 gauge	C8@.757	Ea	408.00	36.00	444.00
2'8" or 3'0" wide, 18 gauge	C8@.757	Ea	486.00	36.00	522.00
2'8" or 3'0" wide, 16 gauge	C8@.757	Ea	567.00	36.00	603.00
3'0" wide, 20 gauge	C8@.816	Ea	435.00	38.80	473.80
Additional costs for hollow metal doors, cost per door					
Add for steel astragal set on site	C8@.496	Ea	56.80	23.60	80.40
Add for factory applied steel astragal	—	Ea	56.80	—	56.80
Add for 90-minute "B" fire label rating	—	Ea	64.20	—	64.20
Add for R-7 polyurethane foam core	—	Ea	145.00	—	145.00
Add for 10" x 10" wired glass panel	—	Ea	109.00	—	109.00
Add for closer reinforcing plate	—	Ea	21.50	—	21.50
Add for chain or bolt reinforcing plate	—	Ea	161.00	—	161.00
Add for rim exit latch reinforcing	—	Ea	46.30	—	46.30
Add for vertical exit latch reinforcing	—	Ea	83.90	—	83.90
Add for pull plate reinforcing	—	Ea	33.80	—	33.80
Add for galvanizing 1-3/8" doors	—	Ea	41.10	—	41.10
Add for galvanizing 1-3/4" door	—	Ea	50.10	—	50.10
Add for cutouts to 4 SF	—	Ea	89.30	—	89.30
Add for cutouts over 4 SF	—	SF	18.80	—	18.80
Add for stainless steel doors	—	Ea	1,510.00	—	1,510.00
Add for baked enamel finish	—	Ea	114.00	—	114.00
Add for porcelain enamel finish	—	Ea	271.00	—	271.00
Add for larger sizes	—	SF	6.18	—	6.18
Add for special dapping	—	Ea	48.40	—	48.40

Right Hand Doors

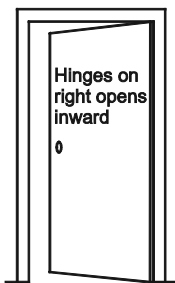

Right Hand Doors Reverse

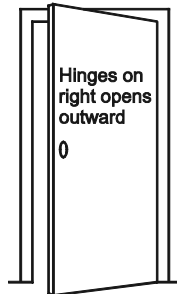

Left Hand Doors

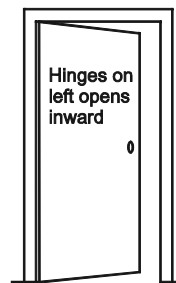

Left Hand Doors Reverse

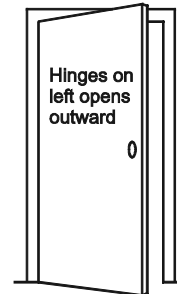

08 Openings

	Craft@Hrs	Unit	Material	Labor	Total
Hollow Metal Door Frames 18 gauge prefinished hollow metal door frames, non-rated, stock sizes, for 1-3/4" or 1-3/8" doors. These costs do not include the door, hinges, lockset, trim or finishing.					
6'8" high					
To 3'6" wide, to 4-1/2" jamb	C8@.944	Ea	150.00	44.90	194.90
To 3'6" wide, 4-3/4" to 6" jamb	C8@.944	Ea	156.00	44.90	200.90
To 3'6" wide, over 6" jamb	C8@.944	Ea	209.00	44.90	253.90
Over 4' wide, 4-1/2" jamb	C8@.944	Ea	178.00	44.90	222.90
Over 4' wide, 4-3/4" to 6" jamb	C8@.944	Ea	188.00	44.90	232.90
Over 4' wide, over 6" jamb	C8@.944	Ea	241.00	44.90	285.90
7' high					
To 3'6" wide, to 4-1/2" jamb	C8@.944	Ea	161.00	44.90	205.90
To 3'6" wide, 4-3/4" to 6" jamb	C8@.944	Ea	170.00	44.90	214.90
To 3'6" wide, over 6" jamb	C8@.944	Ea	221.00	44.90	265.90
Over 4' wide, 4-1/2" jamb	C8@.944	Ea	191.00	44.90	235.90
Over 4' wide, 4-3/4" to 6" jamb	C8@.944	Ea	199.00	44.90	243.90
Over 4' wide, over 6" jamb	C8@.944	Ea	254.00	44.90	298.90
8' high					
To 3'6" wide, to 4-1/2" jamb	C8@1.05	Ea	186.00	50.00	236.00
To 3'6" wide, 4-3/4" to 6" jamb	C8@1.05	Ea	197.00	50.00	247.00
To 3'6" wide, over 6" jamb	C8@1.05	Ea	253.00	50.00	303.00
Over 4' wide, 4-1/2" jamb	C8@1.05	Ea	214.00	50.00	264.00
Over 4' wide, 4-3/4" to 6" jamb	C8@1.05	Ea	220.00	50.00	270.00
Over 4' wide, over 6" jamb	C8@1.05	Ea	285.00	50.00	335.00
Cost additions or deductions for hollow metal door frames					
Add for concrete filled frames	C8@.382	Ea	11.60	18.20	29.80
Add for borrowed lite	C8@.086	SF	11.20	4.09	15.29
Add for fixed transom lite	C8@.099	SF	14.90	4.71	19.61
Add for movable transom lite	C8@.107	SF	16.90	5.09	21.99
Add for window frame sections	C8@.071	LF	9.04	3.38	12.42
Add for wall frame sections	C8@.071	LF	10.30	3.38	13.68
Add for 90-minute UL label	—	Ea	44.80	—	44.80
Add for aluminum casing	—	Ea	37.10	—	37.10
Add for communicator frame (back-to-back doors)	—	Ea	27.40	—	27.40
Add for lengthening, 7' to 8'10"	—	Ea	23.80	—	23.80
Add for extra hinge reinforcing	—	Ea	8.14	—	8.14
Add for stainless steel frames	—	Ea	781.00	—	781.00
Add for porcelain enamel finish	—	Ea	254.00	—	254.00
Add for reinforcing for chain and bolt	—	Ea	10.40	—	10.40
Add for closer plate reinforcing	—	Ea	9.23	—	9.23
Add for exit latch reinforcing	—	Ea	17.00	—	17.00
Deduct for 22 gauge frames	—	Ea	-18.30	—	-18.30
Add for 16 gauge frames	—	Ea	18.50	—	18.50
Add for 14 gauge frames	—	Ea	30.80	—	30.80
Add for galvanized finish	—	%	12.0	—	—
Prehung Steel Doors 18 gauge primed insulated 1-3/4" thick entry doors with sweep and 18 gauge steel frame. Costs shown include three 4" x 4" x 1/4" hinges but no lockset.					
Flush doors					
Jamb to 5-1/2" wide, 2'8" x 6'8", or 3'0" x 6'8"	C8@1.05	Ea	645.00	50.00	695.00
Jamb over 5-1/2" wide, 2'8" x 6'8", or 3'0" x 6'8"	C8@1.05	Ea	661.00	50.00	711.00
6 or 8 panel doors					
Jamb to 5-1/2" wide, 2'8" x 6'8", or 3'0" x 6'8"	C8@1.05	Ea	667.00	50.00	717.00
Jamb over 5-1/2" wide, 2'8" x 6'8", or 3'0" x 6'8"	C8@1.05	Ea	677.00	50.00	727.00

08 Openings

	Craft@Hrs	Unit	Material	Labor	Total
Additional costs for prehung steel doors					
90-minute Factory Mutual fire rating	—	Ea	33.20	—	33.20
60-minute Factory Mutual fire rating	—	Ea	25.50	—	25.50
Add for 16 gauge door and frame	—	Ea	20.10	—	20.10
Deduct for 22 gauge and door	—	Ea	-4.73	—	-4.73
Add for galvanized steel finish	—	Ea	17.60	—	17.60
Deduct for unfinished door	—	Ea	-18.30	—	-18.30
Add for installed weatherstripping	—	Ea	50.90	—	50.90
Add for aluminum threshold	—	Ea	50.60	—	50.60

Doors and Frames Commercial and institutional quality. Unfinished, no hardware included.

Hardwood, hollow core 1-3/8" thick prehung flush interior doors, 4-9/16 in. door frame.

2'0" x 6'8"	C8@.936	Ea	221.00	44.60	265.60
2'4" x 6'8"	C8@.936	Ea	247.00	44.60	291.60
2'8" x 6'8"	C8@.936	Ea	245.00	44.60	289.60
3'0" x 6'8"	C8@.936	Ea	200.00	44.60	244.60

Steel 1-3/4" thick prehung flush exterior doors, welded steel 4-7/8" frame, 1-1/2 hour fire rating, with hardware.

3'0" x 6'8", knocked down frame	C8@1.10	Ea	539.00	52.40	591.40
3'0" x 7'0", knocked down frame	C8@1.10	Ea	549.00	52.40	601.40
3'0" x 6'8", assembled frame	C8@.982	Ea	581.00	46.70	627.70
3'0" x 7'0", assembled frame	C8@.982	Ea	592.00	46.70	638.70
3'0" x 6'8", with panic bar hardware	C8@1.01	Ea	814.00	48.10	862.10
3'0" x 7'0", with panic bar hardware	C8@1.01	Ea	602.00	48.10	650.10

Fiberglass foam core 1-3/4" thick prehung exterior doors

2'8" x 6'8", colonial panel face	C8@.982	Ea	230.00	46.70	276.70
3'0" x 6'8", colonial panel face	C8@1.01	Ea	230.00	48.10	278.10
2'8" x 6'8", French 15-lite	C8@.982	Ea	378.00	46.70	424.70
3'0" x 6'8", French 15-lite	C8@1.01	Ea	378.00	48.10	426.10

Craft@Hrs	Unit	Material	Labor	Equipment	Total
-----------	------	----------	-------	-----------	-------

Special Doors Add the cost of electrical work. Equipment is a 4,000 lb. forklift.

Sliding metal clad fire doors including electric motor

Light duty, minimum	H5@.249	SF	52.50	13.70	1.75	67.95
Light duty, maximum	H5@.405	SF	91.60	22.20	2.85	116.65
Heavy duty, minimum	H5@.600	SF	105.00	33.00	4.23	142.23
Heavy duty, maximum	H5@.750	SF	180.00	41.20	5.29	226.49

Fire doors, overhead roll-up type, sectional steel, fusible link, UL label

6' x 7', manual operation	F7@13.4	Ea	3,040.00	692.00	118.00	3,850.00
5' x 8', manual operation	F7@13.4	Ea	2,050.00	692.00	118.00	2,860.00
14' x 14', chain hoist operated	F7@26.2	Ea	5,980.00	1,350.00	231.00	7,561.00
18' x 14', chain hoist operated	F7@32.9	Ea	8,250.00	1,700.00	289.00	10,239.00

08 Openings

	Craft@Hrs	Unit	Material	Labor	Equipment	Total
Sliding metal fire doors. Motor operated, 3-hour rating, with fusible link. Add the cost of electrical hookup						
3' x 6'8"	H5@16.0	Ea	4,860.00	879.00	113.00	5,852.00
3'8" x 6'8"	H5@16.0	Ea	5,190.00	879.00	113.00	6,182.00
4' x 8'	H5@16.0	Ea	5,370.00	879.00	113.00	6,362.00
5' x 8'	H5@16.0	Ea	5,580.00	879.00	113.00	6,572.00
6' x 8'	H5@16.0	Ea	6,660.00	879.00	113.00	7,652.00
Refrigerator doors, manually operated, 4", with hardware and standard frame						
Galvanized, cooler, 3' x 7', hinged	F7@6.60	Ea	2,590.00	341.00	58.10	2,989.10
Stainless, cooler, 3' x 7', hinged	F7@6.60	Ea	2,950.00	341.00	58.10	3,349.10
Stainless, freezer, 3' x 7', hinged	F7@6.60	Ea	3,860.00	341.00	58.10	4,259.10
Stainless, cooler, 4' x 7', hinged	F7@6.60	Ea	3,340.00	341.00	58.10	3,739.10
Galvanized, cooler, 5' x 7', sliding	F7@7.93	Ea	4,400.00	409.00	69.90	4,878.90
Galvanized, freezer, 5' x 7' sliding	F7@7.93	Ea	4,400.00	409.00	69.90	4,878.90
Hangar doors, including hardware and motorized opener. Costs based on 150' wide doors, installed with a 25 ton hydraulic truck crane.						
To 20' high	H5@.213	SF	33.40	11.70	14.40	59.50
20' to 40' high	H5@.142	SF	43.20	7.80	9.63	60.63
40' to 60' high	H5@.085	SF	50.80	4.67	5.76	61.23
60' to 80' high	H5@.061	SF	60.50	3.35	4.13	67.98
More than 80' high	H5@.047	SF	100.00	2.58	3.19	105.77
Revolving doors, 6'6" to 7' diameter, manual controls						
Aluminum	F7@50.3	Ea	36,700.00	2,600.00	443.00	39,743.00
Stainless steel	F7@50.3	Ea	46,700.00	2,600.00	443.00	49,743.00
Bronze	F7@69.0	Ea	54,000.00	3,560.00	608.00	58,168.00
Add for automatic door controls	—	%	40.0	—	—	—
Security grilles, aluminum, overhead roll-up type, horizontal 5/16" rods at 2" OC, chain hoist operated						
8' x 8', clear anodized aluminum	F7@18.5	Ea	3,370.00	955.00	163.00	4,488.00
8' x 8', medium bronze aluminum	F7@18.5	Ea	4,760.00	955.00	163.00	5,878.00
10' x 10', anodized aluminum	F7@21.8	Ea	4,510.00	1,130.00	192.00	5,832.00
16' x 15', anodized, motor operated	F7@28.7	Ea	8,310.00	1,470.00	253.00	9,407.00
18' x 8', anodized aluminum	F7@26.3	Ea	6,920.00	1,360.00	232.00	8,512.00
18' x 8', anodized, motor operated	F7@28.7	Ea	8,070.00	1,480.00	253.00	9,803.00
Service doors, aluminum, overhead roll-up type						
4' x 4', manual counter shutter	F7@13.6	Ea	1,390.00	702.00	120.00	2,212.00
8' x 4', manual operation	F7@12.7	Ea	1,990.00	656.00	112.00	2,758.00
10' x 10', chain hoist operated	F7@12.7	Ea	3,050.00	656.00	112.00	3,818.00
Insulated overhead aluminum doors, roll-up, 22 gauge interior, 20 gauge exterior, 115 v. operator, with side seals, electric safety edge and button station. With two dock bumpers and electrical hookup only.						
6' x 10', R-7 insulation	F7@12.7	Ea	3,620.00	649.00	112.00	4,108.00
8' x 10', R-8 insulation	F7@13.6	Ea	5,160.00	696.00	120.00	5,993.00
Add for powder coat finish	—	%	25.0	—	—	—
Service doors, steel, overhead roll-up, chain hoist operated						
8' x 8'	F7@11.7	Ea	2,020.00	604.00	103.00	2,727.00
10' x 10'	F7@11.7	Ea	2,480.00	604.00	103.00	3,187.00
12' x 12'	F7@14.7	Ea	3,340.00	759.00	130.00	4,229.00
14' x 14'	F7@18.2	Ea	3,630.00	940.00	160.00	4,730.00
18' x 18'	F7@22.0	Ea	4,930.00	1,140.00	194.00	6,264.00
18' x 14', 240 volt motor operated	F7@25.0	Ea	6,410.00	1,290.00	220.00	7,920.00

08 Openings

	Craft@Hrs	Unit	Material	Labor	Equipment	Total
Sliding glass doors with 1/4" tempered float glass including frame, trim, and hardware						
6-0' wide economy grade	C8@2.75	Ea	1,290.00	131.00	—	1,421.00
6-0' wide premium grade	C8@3.00	Ea	1,500.00	143.00	—	1,643.00
12-0' wide economy grade	C8@4.80	Ea	2,040.00	228.00	—	2,268.00
12-0' wide premium grade	C8@5.00	Ea	3,010.00	238.00	—	3,248.00
Sliding glass doors with 5/8" insulating glass including frame, trim, and hardware						
6-0' wide economy grade	C8@2.75	Ea	1,830.00	131.00	—	1,961.00
6-0' wide premium grade	C8@3.00	Ea	2,210.00	143.00	—	2,353.00
12-0' wide economy grade	C8@4.80	Ea	2,510.00	228.00	—	2,738.00
12-0' wide premium grade	C8@5.00	Ea	3,590.00	238.00	—	3,828.00
Telescoping doors, with frame, enamel finish, electric operated						
10' high x 10' wide	H5@15.0	Ea	13,300.00	824.00	106.00	14,230.00
20' high x 10' wide	H5@19.3	Ea	21,000.00	1,060.00	136.00	22,196.00
20' high x 12' wide	H5@24.0	Ea	22,900.00	1,320.00	169.00	24,389.00
20' high x 16' wide	H5@26.4	Ea	27,500.00	1,450.00	186.00	29,136.00
Accordion folding doors, 4-1/2" wide, nylon wheels hung from straight track, with fittings, 6'8" to 12' high, manual operation, per SF of opening						
Vinyl surface	C8@.051	SF	27.60	2.43	—	30.03
Birch or oak veneer	C8@.051	SF	44.80	2.43	—	47.23
Clear or bronze acrylic	C8@.051	SF	52.40	2.43	—	54.83
Clear or bronze acrylic, with security	C8@.051	SF	63.00	2.43	—	65.43
Anodized aluminum, solid	C8@.051	SF	61.70	2.43	—	64.13
Anodized aluminum, perforated	C8@.051	SF	77.50	2.43	—	79.93
Add for curved track	C8@.102	LF	22.90	4.86	—	27.76
Add for hat channel (suspended ceiling) mount	C8@.102	LF	11.50	4.86	—	16.36
Add for sound rated folding doors	—	SF	8.61	—	—	8.61
Add for locking bolt, per side	—	Ea	50.40	—	—	50.40
Add for fire retardant accordion folding doors	—	%	40.0	—	—	—
Deduct for finished one side (closet) doors	—	%	-10.0	—	—	—
Air curtains. Add the cost of motor starters, transformers, door switches and temperature controls. Unheated, with minimal wind stoppage. Per linear foot of opening width.						
8-0' high, multiples of 3'-0" wide	C8@3.70	LF	357.00	176.00	—	533.00
10-0' high, multiples of 4'-0" wide	C8@3.80	LF	367.00	181.00	—	548.00
12-0' high, multiples of 3'-6" wide	C8@3.90	LF	384.00	186.00	—	570.00
16-0' high, multiples of 3'-6" wide	C8@4.00	LF	462.00	190.00	—	652.00
Add for high wind stoppage	—	%	20.0	—	—	—
Add for heated units	—	%	75.0	—	—	—
Door louvers. Non-vision design recommended for schools, Class "A" and institutional buildings. Suitable for both wood and metal doors. Manufactured from 18 gauge steel with a Jet Kote finish and supplied with #8-3/4" Phillips (pan head) L&L Louvers.						
12" x 12"	C8@.500	Ea	53.40	23.80	—	77.20
18" x 12"	C8@.500	Ea	66.60	23.80	—	90.40
18" x 18"	C8@.500	Ea	75.30	23.80	—	99.10
24" x 12"	C8@.500	Ea	77.90	23.80	—	101.70
24" x 18"	C8@.500	Ea	87.80	23.80	—	111.60
24" x 24"	C8@.500	Ea	112.00	23.80	—	135.80

08 Openings

	Craft@Hrs	Unit	Material	Labor	Equipment	Total
See-thru door frames. (Vision Lite). Recommended for applications where total visibility, light transmission and security are required. The beveled style frame provides a wider field of vision. Manufactured from 18 gauge Jetkote (steel). Installation screws are #8 x 2" Phillips flat head screws. Add the cost of glass below. L&L Louvers.						
6" x 27"	C8@.500	Ea	52.50	23.80	—	76.30
7" x 22"	C8@.500	Ea	49.30	23.80	—	73.10
12" x 12"	C8@.500	Ea	35.60	23.80	—	59.40
18" x 18"	C8@.500	Ea	59.00	23.80	—	82.80
24" x 24"	C8@.500	Ea	64.30	23.80	—	88.10
24" x 30"	C8@.500	Ea	69.90	23.80	—	93.70
24" x 36"	C8@.500	Ea	74.00	23.80	—	97.80
1/4" Wire glass for see-thru door frames						
6" x 27"	—	Ea	42.10	—	—	42.10
7" x 22"	—	Ea	42.30	—	—	42.30
12" x 12"	—	Ea	42.80	—	—	42.80
18" x 18"	—	Ea	58.20	—	—	58.20
24" x 24"	—	Ea	69.00	—	—	69.00
24" x 30"	—	Ea	74.10	—	—	74.10
24" x 36"	—	Ea	79.50	—	—	79.50

	Craft@Hrs	Unit	Material	Labor	Total
Steel access doors, 1" frame, concealed hinge, screwdriver access					
12" x 12", galvanized	CC@.250	Ea	36.00	13.40	49.40
14" x 14", galvanized	CC@.250	Ea	38.20	13.40	51.60
18" x 18"	CC@.275	Ea	52.60	14.70	67.30
14" x 14", vinyl	CC@.250	Ea	18.10	13.40	31.50

	Craft@Hrs	Unit	Material	Labor	Equipment	Total
Stock room doors, double-action .063" aluminum, with hardware and bumper strips both sides, 7' high doors, plastic laminate finish, 12" high baseplate in each door						
2' wide opening, 1 door	F7@1.70	Ea	320.00	87.80	15.00	422.80
2'6" wide opening, 1 door	F7@1.70	Ea	357.00	87.80	15.00	459.80
3' wide opening, 1 door	F7@1.80	Ea	393.00	92.90	15.90	501.80
3'6" wide opening, 1 door	F7@1.90	Ea	438.00	98.10	16.70	552.80
4' wide opening, 2 doors, per pair	F7@3.36	Pr	639.00	173.00	29.60	841.60
5' wide opening, 2 doors, per pair	F7@3.36	Pr	716.00	173.00	29.60	918.60
6' wide opening, 2 doors, per pair	F7@3.98	Pr	786.00	205.00	35.10	1,026.10
7' wide opening, 2 doors, per pair	F7@3.98	Pr	853.00	205.00	35.10	1,093.10
Add for automatic openers, per pair	F7@8.00	Pr	2,470.00	409.00	—	2,689.00
Vault doors, minimum security						
3' x 7', 2 hour fire rating	F7@22.0	Ea	3,720.00	1,140.00	194.00	5,054.00
4' x 7', 2 hour fire rating	F7@23.4	Ea	5,340.00	1,210.00	206.00	6,756.00
3' x 7', 4 hour fire rating	F7@27.2	Ea	4,090.00	1,400.00	239.00	5,729.00
4' x 7', 4 hour fire rating	F7@28.7	Ea	5,560.00	1,480.00	253.00	7,293.00

Flexible strip doors Suitable for interior or exterior use. High strength USDA-approved clear transparent PVC plastic strips, with aluminum mounting hardware. Typical uses include truck dock door openings, railway car entrances, freezer doors and as positive draft protection to check the flow of unwanted air at +140 degrees to -40 degrees F. Costs shown per SF are per square foot of flexible strip area. To calculate the flexible strip area, add 2 linear feet to the opening width and height to allow for coverage at the sides and top. Costs shown per LF are per linear foot of mounting hardware. To calculate the length of the mounting hardware, add 2 LF to the opening width. Labor costs are based on work performed using ladders. Add the cost of scaffolding if required.

08 Openings

	Craft@Hrs	Unit	Material	Labor	Total
Openings to 8' in height, 8" wide strips x .080" thick					
With 1/2 strip overlap	C8@.058	SF	6.05	2.76	8.81
With 3/4 strip overlap	C8@.076	SF	6.71	3.62	10.33
With full strip overlap	C8@.096	SF	9.36	4.57	13.93
Openings over 8' to 14' in height, 12" wide strips x .120" thick					
With 2/3 strip overlap	C8@.100	SF	10.70	4.76	15.46
With full strip overlap	C8@.115	SF	12.80	5.47	18.27
Openings over 14' to 20' in height, 16" wide strips x .120" thick					
With 1/2 strip overlap	C8@.075	SF	11.50	3.57	15.07
With 3/4 strip overlap	C8@.100	SF	15.10	4.76	19.86
With full strip overlap	C8@.125	SF	17.20	5.95	23.15
Add for mounting hardware, aluminum, pre-drilled, complete with nuts, bolts, washers and flex strip mounting pins					
Ceiling- or header-mounted (1.5 lbs per LF)	C8@.400	LF	15.30	19.00	34.30
Wall-mounted (2.5 lbs per LF)	C8@.500	LF	55.80	23.80	79.60

Store front windows, subcontract

Typical subcontract prices including clear anodized thermally broken aluminum framing sections, including shop drawings and exterior caulking, add the cost of glass below. Per SF of wall opening.

2" x 4-1/2" sections	—	LF	—	—	35.50
1-3/4" x 4-1/2" sections	—	LF	—	—	33.80
Hinged entry door, 3' x 6'8", with closer and pulls	—	Ea	—	—	1,390.00
Stanley Dura-Glide bi-parting sliding automatic doors, per 14' x 7' 8" opening, with sensors and glass	—	Ea	—	—	7,660.00
Spandrel glass for aluminum storefront					
1" solar low-E insulated glass	—	SF	—	—	7.27
Tempered glass for automatic entry door, per door	—	Ea	—	—	853.00

Window tint film Applied on site. Full roll quantities. Partial rolls will cost more per square foot. Smaller windows will increase labor costs

Silver tint, 99% UV block, 20% to 50% light transmission	G1@.066	SF	1.15	3.22	4.37
Solar control, dual reflective, 45% to 70% light transmission	G1@.066	SF	1.56	3.22	4.78
Exterior safety film, 4 mil, clear, resists impact, 88% light transmission	G1@.085	SF	1.19	4.15	5.34
3M Prestige, sun control, safety or decorative, typical cost, with warranty	G1@.085	SF	6.90	4.15	11.05

Commercial and industrial grade steel windows, glazed. Per SF of wall opening.

Industrial grade, fixed 100%	G1@.086	SF	20.90	4.20	25.10
Industrial grade, vented 50%	G1@.086	SF	27.00	4.20	31.20
Projected, vented 50%	G1@.086	SF	30.10	4.20	34.30
Add for screen, SF of screen	—	SF	3.63	—	3.63

Custom wood windows. Architectural grade. Pine interior, vinyl-clad exterior, insulating. Argon-filled low-E insulating glass, with hardware and weatherstripping, stationary

20" x 53"	CG@.500	Ea	687.00	28.00	715.00
26" x 26"	CG@.500	Ea	538.00	28.00	566.00
36" x 36"	CG@.500	Ea	687.00	28.00	715.00
36" x 53"	CG@1.00	Ea	910.00	56.10	966.10
36" x 75"	CG@1.00	Ea	973.00	56.10	1,029.10
40" x 19"	CG@.500	Ea	487.00	28.00	515.00
72" x 75"	CG@1.00	Ea	1,940.00	56.10	1,996.10
Add for tempered insulating glass	—	SF	19.10	—	19.10

08 Openings

	Craft@Hrs	Unit	Material	Labor	Total
Hardware Commercial and industrial quality. Installation costs include drilling and routing of doors where required.					
Rule of thumb. Use these costs for preliminary estimates.					
Hardware for commercial buildings, per square foot of floor area					
Economy grade, for doors, cabinets, and toilet rooms	CC@.002	SF	.26	.11	.37
Standard grade, for doors, cabinets, and toilet rooms	CC@.004	SF	.56	.21	.77
Hospital, not including panic hardware, per door	CC@2.46	Ea	732.00	132.00	864.00
Office, not including panic hardware, per door	CC@1.57	Ea	352.00	84.00	436.00
School, not including panic hardware, per door	CC@1.94	Ea	490.00	104.00	594.00
Detail cost for individual hardware components					
Cabinet hardware, per LF of face, typical prices					
Commercial grade	CC@.145	LF	16.00	7.76	23.76
Institutional grade	CC@.181	LF	20.10	9.69	29.79
Closer, surface-mounted. Based on Schlage Lock					
Interior doors	CC@.616	Ea	160.00	33.00	193.00
Exterior doors	CC@.709	Ea	151.00	38.00	189.00
Exterior, heavy duty	CC@.894	Ea	176.00	47.90	223.90
Floor-mounted	CC@1.16	Ea	303.00	62.10	365.10
Deadbolts and deadlatches, chrome finish					
Standard deadbolt, single cylinder	CC@.745	Ea	46.40	39.90	86.30
Standard deadbolt, double cylinder	CC@.745	Ea	63.80	39.90	103.70
Standard turnbolt, no cylinder	CC@.745	Ea	35.70	39.90	75.60
Nightlatch, single cylinder	CC@.745	Ea	113.00	39.90	152.90
Nightlatch, double cylinder	CC@.745	Ea	124.00	39.90	163.90
Nightlatch, no cylinder, turnbolt	CC@.745	Ea	96.80	39.90	136.70
Heavy duty deadbolt, single cylinder	CC@.745	Ea	87.00	39.90	126.90
Heavy duty deadbolt, double cylinder	CC@.745	Ea	108.00	39.90	147.90
Heavy duty turnbolt, no cylinder	CC@.745	Ea	87.00	39.90	126.90
Extra heavy deadbolt, single cylinder	CC@.745	Ea	137.00	39.90	176.90
Extra heavy deadbolt, double cylinder	CC@.745	Ea	162.00	39.90	201.90
Add for brass or bronze finish	—	Ea	3.95	—	3.95
Door stops					
Rubber tip, screw base	CC@.060	Ea	6.14	3.21	9.35
Floor-mounted, with holder	CC@.279	Ea	25.40	14.90	40.30
Wall-mounted, with holder	CC@.279	Ea	24.80	14.90	39.70
Overhead-mounted	CC@.528	Ea	146.00	28.30	174.30
Hinges, butt type					
3-1/2" x 3-1/2"	CC@.357	Pr	14.20	19.10	33.30
5" x 5", hospital swing clear	CC@.547	Pr	188.00	29.30	217.30
4", spring, single acting	CC@.243	Pr	46.80	13.00	59.80
4-1/2", heavy duty	CC@.347	Pr	87.30	18.60	105.90
7", spring, double acting	CC@.491	Pr	115.00	26.30	141.30
Floor-mounted, interior, per door	CC@.665	Ea	383.00	35.60	418.60
Floor-mounted, exterior, per 3' door	CC@.665	Ea	412.00	35.60	447.60
Floor-mounted, exterior, over 3' wide door	CC@.799	Ea	872.00	42.80	914.80
Invisible, blind doors, interior, per door	CC@.574	Ea	45.50	30.70	76.20
Invisible, for blind doors, exterior	CC@.574	Pr	57.90	30.70	88.60
Kick plates (see also Plates below)					
10" x 34" 16 gauge, bronze	CC@.452	Ea	61.40	24.20	85.60
10" x 34" 18 gauge, stainless	CC@.452	Ea	50.70	24.20	74.90
Letter drop, for wood doors,					
brass plated	CC@.369	Ea	42.40	19.80	62.20

08 Openings

	Craft@Hrs	Unit	Material	Labor	Total
Locksets					
Heavy duty residential or light duty commercial locksets, chrome finish					
Classroom or storeroom, key lock	CC@.745	Ea	137.00	39.90	176.90
Dummy knob	CC@.247	Ea	25.90	13.20	39.10
Entrance lockset, key lock	CC@.745	Ea	125.00	39.90	164.90
Passage latch, no lock	CC@.689	Ea	59.40	36.90	96.30
Privacy latch, button lock	CC@.689	Ea	71.40	36.90	108.30
Add for lever handle (handicapped)	—	Ea	49.20	—	49.20
Add for brass or bronze finish	—	Ea	8.57	—	8.57
Heavy duty commercial, chrome finish					
Bored entrance lockset	CC@.745	Ea	316.00	39.90	355.90
Grip handle, with trim	CC@.855	Ea	348.00	45.80	393.80
Single deadbolt-lockset	CC@.745	Ea	154.00	39.90	193.90
Double deadbolt-lockset	CC@.745	Ea	202.00	39.90	241.90
Mortise deadbolt-lockset	CC@.855	Ea	348.00	45.80	393.80
No key lock, push-button pad entry	CC@.855	Ea	765.00	45.80	810.80
Add for lever handle (handicapped)	—	Ea	32.90	—	32.90
Add for brass or bronze finish	—	Ea	12.00	—	12.00
Panic type exit door hardware, with trim					
Mortise type, for aluminum, steel or wood doors					
Satin aluminum finish	CC@2.41	Ea	637.00	129.00	766.00
Dark bronze finish	CC@2.41	Ea	654.00	129.00	783.00
Polished chrome finish	CC@2.41	Ea	776.00	129.00	905.00
Add for external lockset	CC@.401	Ea	86.80	21.50	108.30
Rim lock type, for aluminum, steel or wood doors					
Satin aluminum finish	CC@1.50	Ea	466.00	80.30	546.30
Dark bronze finish	CC@1.50	Ea	491.00	80.30	571.30
Polished chrome finish	CC@1.50	Ea	600.00	80.30	680.30
Add for external lockset	CC@.401	Ea	65.40	21.50	86.90
Vertical rod type, satin aluminum finish, with trim					
Aluminum doors, concealed rod	CC@2.14	Ea	618.00	115.00	733.00
Metal or wood doors, external rod	CC@1.79	Ea	647.00	95.80	742.80
Wood doors, concealed rod	CC@2.14	Ea	760.00	115.00	875.00
Add for external lockset	CC@.401	Ea	84.30	21.50	105.80
Add for bronze or black finish	—	%	37.5	—	—
Add for chrome finish	—	%	70.0	—	—
Plates (see also Kick Plates above)					
Pull plates, bronze, 4" x 16"	CC@.190	Ea	50.60	10.20	60.80
Push plates bronze, 4" x 16"	CC@.190	Ea	39.30	10.20	49.50
Surface bolts					
4" bolt	CC@.308	Ea	7.82	16.50	24.32
6" bolt	CC@.310	Ea	10.70	16.60	27.30
Threshold					
Aluminum, 36"	CC@.241	Ea	25.10	12.90	38.00
Bronze, 36"	CC@.241	Ea	103.00	12.90	115.90
Weatherstripping					
Bronze and neoprene, 3' x 7' door					
Wood door	CC@1.53	Ea	27.70	81.90	109.60
Steel door, adjustable	CC@2.32	Ea	66.80	124.00	190.80
Astragal, mortise-mounted, bronze, adjustable	CC@.064	LF	17.20	3.43	20.63
Glue-back foam for 3' x 7' door	CC@.006	LF	.48	.32	.80

08 Openings

	Craft@Hrs	Unit	Material	Labor	Total
Glazing					
Sheet (window) glass					
Single strength "B", 3/32"					
To 60" width plus length	G1@.057	SF	2.23	2.79	5.02
Over 60" to 70" width plus length	G1@.057	SF	2.30	2.79	5.09
Over 70" to 80" width plus length	G1@.057	SF	2.48	2.79	5.27
Over 80" width plus length	G1@.057	SF	2.53	2.79	5.32
Double strength window glass					
Double strength "B", 1/8"					
To 60" width plus length	G1@.057	SF	2.89	2.79	5.68
Over 60" to 70" width plus length	G1@.057	SF	3.01	2.79	5.80
Over 70" to 80" width plus length	G1@.057	SF	3.11	2.79	5.90
Over 80" width plus length	G1@.057	SF	3.21	2.79	6.00
Tempered "B"	G1@.057	SF	4.72	2.79	7.51
Obscure	G1@.057	SF	4.46	2.79	7.25
3/16" glass					
Crystal (clear)	G1@.068	SF	3.86	3.32	7.18
Tempered	G1@.068	SF	6.37	3.32	9.69
1/4" glass					
Float, clear, Quality 3	G1@.102	SF	3.67	4.98	8.65
Float, bronze or gray, Quality 3	G1@.102	SF	3.87	4.98	8.85
Float, obscure	G1@.102	SF	5.58	4.98	10.56
Float, heat absorbing	G1@.102	SF	6.10	4.98	11.08
Float, safety, laminated, clear	G1@.102	SF	6.76	4.98	11.74
Float, tempered	G1@.102	SF	6.10	4.98	11.08
Spandrel, plain	G1@.102	SF	8.23	4.98	13.21
Spandrel, tinted gray or bronze	G1@.102	SF	9.04	4.98	14.02
Tempered, reflective	G1@.102	SF	9.39	4.98	14.37
3/8" glass					
Float, clear	G1@.128	SF	6.29	6.25	12.54
Float, tinted	G1@.128	SF	8.79	6.25	15.04
Obscure, tempered	G1@.128	SF	9.39	6.25	15.64
Corrugated glass	G1@.128	SF	8.06	6.25	14.31
1/2" float, tempered	G1@.157	SF	23.20	7.67	30.87
1" bullet resistant, 12" x 12" panels	G1@1.32	SF	89.90	64.50	154.40
2" bullet resistant, 15 to 20 SF	G1@1.62	SF	53.80	79.20	133.00
Insulating glass, 2 layers of 1/8", 1/2" overall, 10 to 15 square foot lites					
"B" Quality sheet glass	G1@.131	SF	7.13	6.40	13.53
Float, polished bronze or gray	G1@.131	SF	9.94	6.40	16.34
Insulating glass, 2 layers of 1/4" float, 1" overall, 30 to 40 square foot lites					
Clear float glass	G1@.136	SF	10.90	6.64	17.54
Acrylic plastic sheet (Plexiglas), clear except as noted					
11" x 14" .093" thick	—	Ea	7.04	—	7.04
12" x 24" .093" thick	—	Ea	8.41	—	8.41
18" x 24" .093" thick	—	Ea	14.10	—	14.10
24" x 48" .093" thick	—	Ea	39.40	—	39.40
30" x 36" .093" thick	—	Ea	34.40	—	34.40
36" x 48" .093" thick	—	Ea	50.40	—	50.40
36" x 72" .093" thick	—	Ea	73.50	—	73.50
18" x 24" .236" thick	—	Ea	31.30	—	31.30
24" x 48" .236" thick	—	Ea	77.70	—	77.70
30" x 36" .236" thick	—	Ea	76.90	—	76.90
36" x 72" .236" thick	—	Ea	164.00	—	164.00
30" x 36" .093" thick, bronze	—	Ea	35.00	—	35.00

08 Openings

	Craft@Hrs	Unit	Material	Labor	Total
Wired glass, 1/4", Type 3					
Clear	G1@.103	SF	8.40	5.03	13.43
Hammered	G1@.103	SF	7.85	5.03	12.88
Obscure	G1@.103	SF	7.56	5.03	12.59
Mirrors, unframed					
Sheet glass, 3/16"	G1@.103	SF	7.15	5.03	12.18
Float glass, 1/4"	G1@.106	SF	11.10	5.18	16.28
Reflective, 1 way, in wood stops	G1@.118	SF	20.40	5.77	26.17
Small lites, adhesive mount	G1@.057	SF	4.67	2.79	7.46
Polycarbonate sheet glazing. 4' x 8' panels, Cyro					
Impact resistant, weather resistant sheets					
Clear 1/8"	G1@.027	SF	5.63	1.32	6.95
Clear 3/16"	G1@.027	SF	5.92	1.32	7.24
Clear 1/4"	G1@.027	SF	7.67	1.32	8.99
Clear 1/2"	G1@.035	SF	14.10	1.71	15.81
Add for tints	—	%	17.0	—	—
Chemical and abrasion resistant sheets					
Clear 1/8"	G1@.027	SF	8.64	1.32	9.96
Clear 3/16"	G1@.027	SF	9.80	1.32	11.12
Clear 1/4"	G1@.027	SF	14.50	1.32	15.82
Clear 1/2"	G1@.035	SF	21.90	1.71	23.61
Add for tints	—	%	17.0	—	—
Shock absorbent, high light transmission sheets (greenhouse applications)					
Clear 5/16"	G1@.027	SF	8.64	1.32	9.96
Clear 5/8"	G1@.035	SF	9.80	1.71	11.51

09 Finishes

Gypsum Wallboard Commercial grade work. Material costs include 6% for waste.

Costs per square foot of area covered.

Gypsum wallboard nailed or screwed to wood framing or wood furring, no taping or finishing included

3/8" on walls	CD@.007	SF	.43	.37	.80
3/8" on ceilings	CD@.009	SF	.43	.48	.91
3/8" on furred columns and beams	CD@.013	SF	.43	.69	1.12
1/2" on walls	CD@.007	SF	.42	.37	.79
1/2" on ceilings	CD@.009	SF	.42	.48	.90
1/2" on furred columns and beams	CD@.015	SF	.42	.79	1.21
5/8" on walls	CD@.007	SF	.47	.37	.84
5/8" on ceilings	CD@.010	SF	.47	.53	1.00
5/8" on furred columns and beams	CD@.015	SF	.47	.79	1.26

Gypsum wallboard clipped to metal furring, no taping or finishing included. Add the cost of furring from the sections that follow.

3/8" on wall furring	CD@.008	SF	.43	.42	.85
3/8" on ceiling furring	CD@.011	SF	.43	.58	1.01
1/2" on wall furring	CD@.009	SF	.42	.48	.90
1/2" on ceiling furring	CD@.011	SF	.42	.58	1.00
1/2" on column or beam furring	CD@.018	SF	.42	.95	1.37
5/8" on wall furring	CD@.009	SF	.47	.48	.95
5/8" on ceiling furring	CD@.011	SF	.47	.58	1.05
5/8" on column or beam furring	CD@.018	SF	.47	.95	1.42
1/2", two layers on ceiling furring	CD@.022	SF	.85	1.16	2.01
1/2", two layers on furring	CD@.017	SF	.85	.90	1.75
1/4" sound board	CD@.008	SF	.43	.42	.85

09 Finishes

	Craft@Hrs	Unit	Material	Labor	Total
Wallboard finishing. Per ASTM C840. Higher 'level' costs include prior 'levels'.					
Add for taping only, no joint finishing	CD@.115	CSF	1.46	6.07	7.53
Level 1 - taping and finishing wall joints (firtape)	CD@.219	CSF	3.65	11.60	15.25
Level 2 - finishing wall joints	CD@.388	CSF	5.01	20.50	25.51
Level 3 - finishing wall joints	CD@.519	CSF	6.37	27.40	33.77
Level 4 - finishing wall joints	CD@.625	CSF	6.75	33.00	39.75
Level 5 - finishing wall joints, skim entire surface	CD@.713	CSF	8.92	37.70	46.62
Add for taping and finishing ceiling joints	—	%	—	33.3	—
Additional costs for gypsum wallboard					
Add for foil-backed board	—	SF	.07	—	.07
Add for fire resistant board	—	SF	.06	—	.06
Add for water resistant board	—	SF	.18	—	.18
Add for 10' or 12' wall heights	CD@.001	SF	.02	.05	.07
Add for school jobs	CD@.002	SF	—	.11	.11
Add for trowel textured finish	CD@.009	SF	.51	.48	.99
Add for adhesive application, 1/4" bead					
Studs or joists 16" on center	CD@.056	CSF	4.03	2.96	6.99
Studs or joists 24" on center	CD@.042	CSF	2.68	2.22	4.90
Bead, casing and channels					
Corner bead, 1-1/4" x 1-1/4"	CD@.017	LF	.36	.90	1.26
Stop or casing	CD@.021	LF	.33	1.11	1.44
Jamb casing	CD@.023	LF	.33	1.21	1.54
RC-1 channel or 7/8" hat channel	CD@.011	LF	.74	.58	1.32
Vinyl clad gypsum board, adhesive or clip application on walls					
1/2", no moldings included	CD@.010	SF	1.00	.53	1.53
5/8", no moldings included	CD@.011	SF	1.04	.58	1.62
Drywall specialties Commercial grade work. Material costs include 6% for waste.					
Heat and sound reduction					
Noiseproofing adhesive, 28 oz covers 16 SF	CD@.005	SF	1.16	.26	1.42
1/8" sound membrane, applied over studs/joists	CD@.015	SF	5.52	.79	6.31
Hilti CP 777 top of wall 2" firestop and No. 673 joint spray					
New installation CP 777 firestop and spray	CD@.135	LF	3.21	7.13	10.34
Remove and replace CP 777 firestop and spray	CD@.150	LF	3.21	7.92	11.13
Hilti CP 777 top of wall 2" firestop and No. 606 1/2" fire caulk					
New installation CP 777 firestop and caulk	CD@.200	LF	2.30	10.60	12.90
Remove and replace CP 777 firestop and caulk	CD@.250	LF	2.30	13.20	15.50
Hilti CP 606 fire caulk					
Per penetration, CP 606 fire caulk	CD@.500	Ea	4.70	26.40	31.10
Per linear foot, CP 606 fire caulk	CD@.100	LF	1.88	5.28	7.16
Hilti CP 672 speed spray, per linear foot	CD@.068	LF	2.16	3.59	5.75
Wall and slab penetration firestop, intumescent sealant, 1/4" W x 1/2" D					
Average 1" wall penetration	CD@.125	Ea	1.01	6.60	7.61
Opening to 1", wall penetration	CD@.125	Ea	1.07	6.60	7.67
Opening to 1", slab penetration	CD@.175	Ea	.17	9.24	9.41
Opening to 1-1/2" wall penetration	CD@.125	Ea	.16	6.60	6.76
Opening to 1-1/2" slab penetration	CD@.175	Ea	.21	9.24	9.45
Opening to 2-1/2" wall penetration	CD@.125	Ea	.27	6.60	6.87
Opening to 2-1/2" slab penetration	CD@.175	Ea	.31	9.24	9.55
Opening to 4" wall penetration	CD@.125	Ea	.43	6.60	7.03
Opening to 4" slab penetration	CD@.175	Ea	.44	9.24	9.68
Ductwork, per LF of sealant	CD@.125	LF	.38	6.60	6.98
Firestop ceiling bulkhead, furred-out gypsum board on resilient channels					
No existing ceiling	CD@1.10	LF	13.90	58.10	72.00
Light to medium obstructions	CD@1.33	LF	13.90	70.20	84.10
Heavily obstructed	CD@1.50	LF	13.90	79.20	93.10
Control joint reglet	CD@.050	LF	.66	2.64	3.30
Gypsum access panel, glass fiber reinforced, 12" to 36"	CD@2.25	Ea	236.00	119.00	355.00

09 Finishes

	Craft@Hrs	Unit	Material	Labor	Total
Furring and Lathing For commercial applications. See plaster costs in the following section.					
Furring on walls, cold rolled, galvanized					
3/4", 12" on center	C8@.306	SY	6.26	14.60	20.86
3/4", 16" on center	C8@.270	SY	5.45	12.90	18.35
3/4", 24" on center	C8@.207	SY	4.13	9.85	13.98
1-1/2", 12" on center	C8@.342	SY	8.88	16.30	25.18
1-1/2", 16" on center	C8@.297	SY	7.59	14.10	21.69
1-1/2", 24" on center	C8@.234	SY	6.33	11.10	17.43
3-5/8", 12" on center, 25 gauge	C8@.360	SY	13.10	17.10	30.20
3-5/8", 16" on center, 25 gauge	C8@.315	SY	10.30	15.00	25.30
3-5/8", 24" on center, 25 gauge	C8@.261	SY	9.80	12.40	22.20
Furring on ceilings, cold rolled, galvanized					
3/4", 12" on center	C8@.413	SY	6.26	19.70	25.96
3/4", 16" on center	C8@.365	SY	5.45	17.40	22.85
3/4", 24" on center	C8@.280	SY	4.13	13.30	17.43
1-1/2", 12" on center	C8@.462	SY	8.88	22.00	30.88
1-1/2", 16" on center	C8@.400	SY	7.59	19.00	26.59
1-1/2", 24" on center	C8@.316	SY	6.33	15.00	21.33
1-1/2" x 3/4", coffered	C8@.887	SY	9.80	42.20	52.00
Furring on beams and columns, per linear foot of galvanized channel					
7/8" channel	C8@.059	LF	.70	2.81	3.51
1-5/8" channel	C8@.059	LF	.87	2.81	3.68
Resilient channel on beams and columns, per linear foot of channel					
Narrow soundproofing channel, metal	C8@.011	LF	1.27	.52	1.79
Narrow soundproofing channel, PVC	C8@.011	LF	1.23	.52	1.75
Regular soundproofing channel, metal	C8@.011	LF	1.27	.52	1.79
Regular soundproofing channel, with padding tape	C8@.011	LF	1.71	.52	2.23
RC-1 resilient hat channel	C8@.011	LF	.92	.52	1.44
RC-1 resilient hat channel, with padding tape	C8@.011	LF	1.38	.52	1.90
RC-2 resilient hat channel (for ceilings)	C8@.011	LF	1.19	.52	1.71
Ceiling suspension system for lath, installed 7' to 9' above floor level with rod hangers attached to structural steel or metal decking, 1-1/2" main at 24" OC. Add the cost of lath.					
With 3/4" cross at 12" OC	C8@.378	SY	8.49	18.00	26.49
With 3/4" cross at 24" OC	C8@.342	SY	7.56	16.30	23.86
With 1-1/2" cross at 16" OC	C8@.432	SY	9.29	20.60	29.89
With 2-1/2" cross at 24" OC	C8@.360	SY	8.12	17.10	25.22
Metal lath on walls and ceilings, nailed in place, includes 8% for fasteners and waste.					
2.5 lb., diamond lath	F8@.107	SY	4.23	5.59	9.82
2.5 lb., paper-backed	F8@.107	SY	5.46	5.59	11.05
3.4 lb., diamond lath	F8@.119	SY	5.38	6.21	11.59
3.4 lb., paper-backed	F8@.114	SY	6.62	5.95	12.57
3.4 lb., 3/8" high ribbed lath	F8@.121	SY	6.73	6.32	13.05
3.4 lb., 1/8" low ribbed lath	F8@.124	SY	7.07	6.47	13.54
Add for galvanized metal lath	—	%	10.0	—	—
Add for metal lath wired in place	—	%	—	15.0	—
Add for metal lath on columns and beams	—	%	—	100.0	—
Stucco mesh, reverse twist, self-furring, galvanized, includes 5% waste					
1" mesh, 18 gauge	F8@.079	SY	2.93	4.12	7.05
1-1/2" mesh, 17 gauge	F8@.079	SY	1.91	4.12	6.03
1-1/2" mesh, 17 gauge, paper back	F8@.079	SY	2.96	4.12	7.08
Gypsum lath, perforated or plain, clipped to metal studs					
3/8" regular	F8@.090	SY	3.73	4.70	8.43
3/8" firestop	F8@.090	SY	4.12	4.70	8.82

09 Finishes

	Craft@Hrs	Unit	Material	Labor	Total
3/8" foil back	F8@.090	SY	4.30	4.70	9.00
1/2" regular	F8@.090	SY	3.87	4.70	8.57
1/2" firestop	F8@.090	SY	4.26	4.70	8.96
1/2" foil back	F8@.090	SY	4.46	4.70	9.16
Add for application to ceilings	—	%	—	50.0	—
Add for application to columns or beams	—	%	—	80.0	—
Deduct for gypsum lath screwed in place	—	%	-2.0	-5.0	—
Plaster bead, 1-3/4" perforated flange					
1" casing bead	F8@.025	LF	.54	1.31	1.85
1-1/4" casing bead	F8@.025	LF	.67	1.31	1.98
1-1/2" casing bead	F8@.025	LF	.83	1.31	2.14
3/4" casing bead, expanded wing	F8@.037	LF	1.70	1.93	3.63
2" casing bead	F8@.025	LF	.93	1.31	2.24
Square nose stop and casing	F8@.025	LF	.92	1.31	2.23
3/4" radius corner bead	F8@.025	LF	1.00	1.31	2.31
Expanded nose corner bead	F8@.025	LF	1.89	1.31	3.20
Control joints, 4" perforated flange					
1/2" joint	F8@.035	LF	1.13	1.83	2.96
5/8" joint	F8@.035	LF	1.22	1.83	3.05
3/4" joint	F8@.035	LF	1.26	1.83	3.09
3/4" joint, expanded wing	F8@.037	LF	4.03	1.93	5.96
7/8" joint	F8@.035	LF	1.56	1.83	3.39
Expansion joints, slip type					
3/4", 26 gauge, 1 piece	F8@.025	LF	1.89	1.31	3.20
1/4" to 5/8" adjustment, 1/2" to 3/4" deep	F8@.035	LF	2.87	1.83	4.70
1/4" to 5/8" adjustment, 7/8" deep	F8@.035	LF	3.13	1.83	4.96
5/8" to 1-1/8" adjustment, 1/2" to 3/4" deep	F8@.035	LF	3.03	1.83	4.86
5/8" to 1-1/8" adjustment, 7/8" deep	F8@.035	LF	3.13	1.83	4.96
1-1/8" to 1-5/8" adjustment, 1/2" to 3/4" deep	F8@.035	LF	3.03	1.83	4.86
1-1/8" to 1-5/8" adjustment, 7/8" deep	F8@.035	LF	3.14	1.83	4.97
Lathing accessories					
Base screed, 1/2", 26 gauge	F8@.032	LF	1.23	1.67	2.90
Vents, 1-1/2", galvanized	F8@.042	LF	3.43	2.19	5.62
Vents, 4", galvanized	F8@.061	LF	4.04	3.18	7.22
Archbead, plastic nose	F8@.028	LF	2.04	1.46	3.50
Stud clips for gypsum lath, field clip	F8@.004	Ea	.15	.21	.36
Joist clips for lath	F8@.005	Ea	.15	.26	.41
2-1/2" metal base, galvanized	F8@.042	LF	.93	2.19	3.12
Tie wire, 16.5 gauge, 400' roll	—	Ea	7.02	—	7.02
Plastering These costs do not include the furring or lath					
Gypsum interior plaster, lime putty trowel finish					
Two coat application, on ceilings	F8@.381	SY	12.30	19.90	32.20
Two coat application, on walls	F8@.330	SY	12.30	17.20	29.50
Three coat application, on ceilings	F8@.448	SY	16.10	23.40	39.50
Three coat application, on walls	F8@.405	SY	16.10	21.10	37.20
Gypsum interior vermiculite plaster, trowel finish					
Two coat application, on ceilings	F8@.381	SY	12.90	19.90	32.80
Two coat application, on walls	F8@.330	SY	12.90	17.20	30.10
Three coat application, on ceilings	F8@.448	SY	16.70	23.40	40.10
Three coat application, on walls	F8@.405	SY	16.70	21.10	37.80
Keene's cement plaster, troweled lime putty, medium hard finish					
Two coat application, on ceilings	F8@.435	SY	17.50	22.70	40.20
Two coat application, on walls	F8@.381	SY	17.50	19.90	37.40

09 Finishes

	Craft@Hrs	Unit	Material	Labor	Total
Three coat application, on ceilings	F8@.521	SY	22.80	27.20	50.00
Three coat application, on walls	F8@.459	SY	22.80	24.00	46.80
Portland cement stucco on exterior walls, scratch, brown and finish coats totaling 1" thick					
Natural gray, sand float finish	F8@.567	SY	10.00	29.60	39.60
Natural gray, trowel finish	F8@.640	SY	10.00	33.40	43.40
White cement, sand float finish	F8@.575	SY	13.20	30.00	43.20
White cement, trowel finish	F8@.650	SY	13.20	33.90	47.10
Deduct for spray pump application	—	%	—	-20.0	—
Add for a peristaltic stucco sprayer, per day	—	Ea	300.00	—	300.00
Portland cement stucco on soffits, scratch, brown and finish coats totaling 1" thick					
Natural gray, sand float finish	F8@.678	SY	10.00	35.40	45.40
Natural gray, trowel finish	F8@.829	SY	10.00	43.30	53.30
White cement, sand float finish	F8@.878	SY	13.20	45.80	59.00
White cement, trowel finish	F8@1.17	SY	13.20	61.10	74.30
Brown and scratch coat base for tile	F8@.308	SY	6.79	16.10	22.89
Scratch coat only for tile	F8@.152	SY	3.01	7.93	10.94
Thin coat plaster, 2 coats, with rock lath but not including studs					
3/8" rock lath (gypsum lath)	F8@.265	SY	14.00	13.80	27.80
Simulated acoustic texture, sometimes called "popcorn" or "cottage cheese"					
On ceilings	F8@.052	SY	2.40	2.71	5.11
Texture coat on exterior walls and soffits	F8@.045	SY	2.40	2.35	4.75
Patching gypsum plaster, including lath repair but no studding					
To 5 SF repairs	P5@.282	SF	2.68	12.90	15.58
Over 5 SF repairs	P5@.229	SF	2.68	10.50	13.18
Repair cracks only (\$150 per job minimum)	P5@.055	LF	.46	2.52	2.98
Plaster moldings, ornate designs					
2"	CC@.090	LF	7.74	4.82	12.56
4"	CC@.115	LF	15.80	6.16	21.96
6"	CC@.132	LF	22.90	7.07	29.97

Metal-Framed Shaft Walls Shaft walls are used to enclose vertical shafts that surround plumbing and electrical chases, elevators and stairwells. A 2-hour wall can be made from 1" gypsum wallboard screwed to a 2-1/2" metal stud partition on the shaft side with two layers of 5/8" gypsum wallboard screwed to the partition exterior face. The wall cavity is filled with fiberglass batt insulation and the drywall is taped and finished on both sides. This wall will be 4-3/4" thick. Labor includes installing metal studs, installing the insulation, hanging, taping and finishing the drywall, and cleanup. Metal studs and insulation include a 10% allowance for waste. Wallboard costs include corner and edge trim and a 15% allowance for waste. Costs shown are per square foot of wall measured on one side. For scheduling purposes, estimate that a crew of 4 can install metal studs and insulation, hang, tape and finish 320 SF of shaft wall per 8-hour day.

Metal studs, "C" section, 2-1/2" wide, 20 gauge, 24" on center

Complete with top runner and bottom plate	C8@.036	SF	.67	1.71	2.38
1" Type "X" gypsum shaftboard	CD@.029	SF	1.81	1.53	3.34
2 layers 5/8" Type "X" gypsum wallboard	CD@.027	SF	1.26	1.43	2.69
Fiberglass insulation, foil faced	A1@.006	SF	.88	.31	1.19
Total for metal framed shaft wall as described	—@.098	SF	4.62	4.98	9.60

Ceramic Tile Set in adhesive and grouted. Add the cost of adhesive below. No scratch or brown coat included. Based on standard U.S. grades and stock colors. Custom colors, designs and imported tile will cost more.

4" x 4" to 12" x 24" glazed wall tile

Smooth gloss glaze, minimum quality	T4@.131	SF	2.18	6.11	8.29
Smooth gloss glaze, standard quality	T4@.131	SF	4.81	6.11	10.92
Matte finish, better quality	T4@.131	SF	6.33	6.11	12.44
High gloss finish	T4@.131	SF	8.44	6.11	14.55

09 Finishes

	Craft@Hrs	Unit	Material	Labor	Total
Commercial quality					
Group 1 (matte glaze)	T4@.131	SF	3.86	6.11	9.97
Group 2 (bright glaze)	T4@.131	SF	4.72	6.11	10.83
Group 3 (crystal glaze)	T4@.131	SF	5.44	6.11	11.55
6" wall tile, smooth glaze					
6" x 6", gray or brown	T4@.131	SF	2.58	6.11	8.69
6" x 8", quilted look	T4@.131	SF	5.24	6.11	11.35
6" x 8", fume look	T4@.131	SF	4.62	6.11	10.73
Trim pieces for glazed wall tile					
Surface bullnose	T4@.077	LF	1.80	3.59	5.39
Surface bullnose corner	T4@.039	Ea	1.18	1.82	3.00
Sink rail or cap	T4@.077	LF	5.22	3.59	8.81
Radius bullnose	T4@.077	LF	2.36	3.59	5.95
Quarter round or bead	T4@.077	LF	2.82	3.59	6.41
Outside corner or bead	T4@.039	Ea	.92	1.82	2.74
Base	T4@.077	LF	6.40	3.59	9.99
Soap holder, soap dish	T4@.265	Ea	14.30	12.40	26.70
Tissue holder, towel bar	T4@.268	Ea	21.20	12.50	33.70
Glazed floor tile, 1/4" thick					
Minimum quality, standard colors	T4@.210	SF	2.92	9.79	12.71
Better quality, patterns	T4@.210	SF	3.50	9.79	13.29
Commercial quality, 6" x 6" to 12" x 12"					
Standard colors, reds and browns	T4@.210	SF	3.35	9.79	13.14
Blues and greens	T4@.210	SF	4.10	9.79	13.89
Add for abrasive surface	—	SF	.35	—	.35
1" x 1" mosaic tile, back-mounted, natural clays					
Group I colors (browns, reds)	T4@.143	SF	2.53	6.67	9.20
Group II colors (tans, grays)	T4@.143	SF	2.76	6.67	9.43
Group III colors (charcoal, blues)	T4@.143	SF	3.04	6.67	9.71
Ceramic tile adhesive, premixed Type 1, 1 gallon covers 70 SF applied with #1 trowel (3/16" x 5/32" "V"-notch), 50 SF applied with #2 trowel (3-/16" x 1/4" "V"-notch) or 40 SF applied with #3 trowel (1/4" x 1/4" square-notch).					
1 quart	—	Ea	6.12	—	6.12
1 gallon	—	Ea	12.30	—	12.30
3-1/2 gallons	—	Ea	38.50	—	38.50
Tile adhesive applied with #2 trowel	—	SF	.23	—	.23
Thin-set tile mortar. 50 pound bag covers 100 SF applied with #1 trowel (1/4" x 1/4" square-notch), 80 SF applied with #2 trowel (1/4" x 3/8" square-notch), 45 SF applied with #3 trowel (1/2" x 1/2" square notch). Cost per 50 pound bag.					
Standard, gray	—	Ea	5.18	—	5.18
Standard, white	—	Ea	7.77	—	7.77
VersaBond, gray	—	Ea	12.10	—	12.10
VersaBond, white	—	Ea	13.00	—	13.00
FlexiBond, gray	—	Ea	32.80	—	32.80
Marble and granite mix	—	Ea	31.10	—	31.10
VersaBond, gray applied with #3 trowel	—	SF	.27	—	.27
Polymer-modified dry grout for joints 1/16" to 1/2". Coverage varies with tile and joint size. Typically, a 25 lb. bag of sanded grout will cover 100 SF of 12" x 12" tile with a 1/8" spacing.					
Un-sanded, 10 lb. bag	—	Ea	14.50	—	14.50
Sanded, all colors, 25 lb. bag	—	Ea	14.00	—	14.00
Saltillo grout, gray, 50 lb. bag	—	Ea	14.40	—	14.40
Decorator tile panels, institutional quality, 6" x 9" x 3/4", typical costs					
Unglazed domestic	T4@.102	SF	5.97	4.76	10.73
Wash-glazed domestic	T4@.102	SF	9.92	4.76	14.68
Full glazed domestic	T4@.102	SF	10.40	4.76	15.16

09 Finishes

	Craft@Hrs	Unit	Material	Labor	Total
Glazed imported, decorative	T4@.102	SF	24.90	4.76	29.66
Deduct for imported tile	—	%	-20.0	—	—
Plastic tile					
12" x 12"	T4@.010	Ea	3.85	.47	4.32
Ramp edges	T4@.010	Ea	1.42	.47	1.89
Aluminum tile, 12" x 12"	T4@.102	SF	42.60	4.76	47.36
Copper on aluminum, 4-1/4" x 4-1/4"	T4@.102	SF	85.10	4.76	89.86
Stainless steel tile, 4-1/4" x 4-1/4"	T4@.102	SF	85.10	4.76	89.86
Quarry tile set in Portland cement					
5" high base tile	T4@.109	LF	4.05	5.08	9.13
4" x 4" x 1/2" floor tile	T4@.096	SF	4.75	4.48	9.23
6" x 6" x 1/2" floor tile	T4@.080	SF	3.90	3.73	7.63
Quarry tile set in furan resin					
5" high base tile	T4@.096	LF	2.80	4.48	7.28
6" x 6" x 3/4" floor tile	T4@.093	SF	6.74	4.34	11.08
Add for abrasive finish	—	SF	.61	—	.61
Acoustical Treatment					
Tile board and panels, applied to a ceiling with staples or adhesive, not including furring.					
Decorative Armstrong ceiling tile,					
Woodhaven plank, 5" x 84" x 3/8", T&G	C8@.017	SF	3.50	.81	2.34
Invisacoustics, 24" x 48" x 3/4", square edge	C8@.017	SF	3.46	.81	3.00
Lyra PB, 24" x 24" x 1", square edge	C8@.017	SF	7.15	.81	4.59
Wood fiber ceiling tile, Advantage Series, USG. Class C panels for non-acoustical and non fire-rated applications.					
Tongue-and-groove edging hides staples for a smooth, clean look. 12" x 12" x 1/2" with staple flange. Stapled or set with adhesive.					
Lace	C8@.017	SF	2.58	.81	3.39
Tivoli	C8@.017	SF	3.00	.81	3.81
White wood fiber	C8@.017	SF	2.90	.81	3.71
Acoustical ceiling tile adhesive, 237, Henry. For use on 12" x 12" to 24" x 24" tile. Bonds to concrete, concrete block, drywall, plaster and brick. 30-minute working time. One gallon typically covers 60 square feet.					
Per square foot	—	SF	.43	—	.43
Sound-absorbing fabric covered wall panels for attaching to structural walls					
AlphaSorb™, style 2100, 1" thick x 4' x 8'	C8@.038	SF	8.87	1.81	10.68
AlphaSorb™, style 2100, 2" thick x 4' x 8'	C8@.038	SF	11.70	1.81	13.51
Anchorage™, panels, 1" thick x 4' x 8'	C8@.038	SF	8.94	1.81	10.75
Anchorage™, panels, 2" thick x 4' x 8'	C8@.038	SF	11.70	1.81	13.51
Impaling clip fastener, per panel	—	Ea	6.23	—	6.23
Add for radius, mitered, or beveled edges, per panel	—	Ea	12.50	—	12.50
"Z"-Clip fasteners, per panel	—	Ea	24.90	—	24.90
Suspended Ceiling Grid Systems 5,000 SF job. Add for ceiling tile below.					
"T"-bar suspension system, no tile included, suspended from ceiling joists with wires					
2' x 2' grid	C8@.011	SF	1.38	.52	1.90
2' x 4' grid	C8@.010	SF	1.04	.48	1.52
4' x 4' grid	C8@.009	SF	.69	.43	1.12
Add for jobs under 5,000 SF					
Less than 2,500 SF	C8@.007	SF	.82	.33	1.15
2,500 SF to 4,500 SF	C8@.005	SF	.59	.24	.83

09 Finishes

	Craft@Hrs	Unit	Material	Labor	Total
Ceiling Tile laid in suspended ceiling grid. No suspended ceiling grid system included. Labor column shows the cost of laying tile in a suspended ceiling grid.					
Armstrong acoustical rated suspended ceiling panels					
2' x 2' x 5/8" Designer, coarse texture	C8@.012	SF	1.67	.57	4.48
2' x 2' x 3/4" School Zone, beveled edge	C8@.012	SF	2.01	.57	3.48
2' x 2' x 5/8" Canyon, smooth finish	C8@.012	SF	2.85	.57	2.54
2' x 2' x 5/8" Tundra, impact and scratch resistant	C8@.012	SF	3.68	.57	3.37
2' x 2' x 5/8", Clean Room VL, square edge	C8@.012	SF	4.35	.57	3.02
2' x 2' x 1" Tectum, natural, paintable	C8@.012	SF	4.46	.57	1.81
2' x 2' x 1", Calla high noise blocking	C8@.012	SF	5.36	.57	4.09
2' x 2' x 1", Painted Nubby, high sound absorption	C8@.007	SF	5.60	.33	1.41
2' x 2' x 3/4", Cirrus Profiles, chamfered edge	C8@.007	SF	8.65	.33	1.92
2' x 4' x 3/4", Clean Room FL, scrubbable	C8@.007	SF	8.80	.33	1.72
2' x 6' x 7/8", Lyra Vector, smooth, concealed grid	C8@.007	SF	10.10	.33	1.87
Non-acoustical suspended ceiling panels					
2' x 4', mineral fiber, USG "Plateau"	C8@.007	SF	.64	.33	.97
2' x 4' x 1/2", Sheetrock® Gypsum Lay-In	C8@.012	SF	1.78	.57	2.35
2' x 4' x 9/16", mineral, USG "Stonehurst"	C8@.007	SF	1.05	.33	1.38
2' x 4' random texture, "A" fire rated	C8@.007	SF	1.59	.33	1.92
2' x 2' x 5/8", USG "Ceramic ClimaPlus"	C8@.012	SF	2.58	.57	3.15
2' x 2' x 3/4", USG "Saville Row"	C8@.012	SF	3.14	.57	3.71
2' x 4' clean room, non-perforated	C8@.007	SF	3.84	.33	4.17
Translucent panels, 2' x 4'					
Clear or frosted prismatic	C8@.004	SF	1.87	.19	2.06
Arctic opal or cracked ice	C8@.004	SF	3.34	.19	3.53
Clear acrylic	C8@.004	SF	1.82	.19	2.01
White acrylic	C8@.004	SF	1.84	.19	2.03
Wood Flooring					
Oak, 3/4" x 2-1/4", unfinished					
Select grade, white	F9@.062	SF	6.00	2.90	8.90
Select, grade, red	F9@.062	SF	6.00	2.90	8.90
Select, grade, ash	F9@.062	SF	5.29	2.90	8.19
Parquet, unfinished, 5/16"					
Ash or quartered oak, select	F9@.053	SF	31.50	2.48	33.98
Ash or quartered oak, natural	F9@.053	SF	22.90	2.48	25.38
Cherry or walnut select grade	F9@.053	SF	36.30	2.48	38.78
Cherry or walnut natural grade	F9@.053	SF	27.40	2.48	29.88
Oak, select plain	F9@.053	SF	25.50	2.48	27.98
Oak, natural plain	F9@.053	SF	22.00	2.48	24.48
Concrete moisture vapor barriers, liquid 1 or 2 part, roll, brush or squeegee applied					
RedGard, per coat, 2 coats typical for waterproofing	FL@.017	SF	.82	.88	1.70
Defender, per coat, 1 coat typical	FL@.017	SF	1.72	.88	2.60
PlaniSeal EMB, per coat, 1 coat typical	FL@.017	SF	3.39	.88	4.27
Gym floors, 3/4", maple, including finishing					
On sleepers and membrane	F9@.086	SF	11.70	4.02	15.72
On steel spring system	F9@.114	SF	13.90	5.33	19.23
Connected with steel channels	F9@.097	SF	12.20	4.54	16.74
Softwood floors, fir, unfinished					
1" x 2"	F9@.031	SF	3.95	1.45	5.40
1" x 3"	F9@.031	SF	3.98	1.45	5.43

09 Finishes

	Craft@Hrs	Unit	Material	Labor	Total
Finishing wood flooring					
Fill and stain	F9@.010	SF	.11	.47	.58
Two coats urethane	F9@.047	SF	.15	2.20	2.35
Wax coating	F9@.001	SF	.03	.05	.08
Sand, scrape and edge hardwood floor					
Large room or hall, using 12" drum sander and 7" disc sander					
Three cuts	F9@.009	SF	.05	.42	.47
Four cuts	F9@.011	SF	.06	.51	.57
Closet or 4' x 10' area, using 7" disc sander					
Three cuts	F9@.010	SF	.04	.47	.51
Four cuts	F9@.012	SF	.04	.56	.60
Resilient Flooring					
Vinyl composition tile, peel and stick					
Speckle, 12" x 12" x 1/8" thick, no wear layer	F9@.016	SF	.76	.75	1.51
Cool white, 12" x 12" x 1/8" thick, acrylic wear layer	F9@.016	SF	.97	.75	1.72
Low gloss, 12" x 12" x 1.5 mm wear layer	F9@.016	SF	1.65	.75	2.40
Sheet vinyl flooring , Includes 10% waste and adhesive.					
Pebble look, 4 mil vinyl wear layer, 14 mm, felt back	FL@.300	SY	5.25	15.60	20.85
Slate look, 10 mil urethane wear layer, 14 mm	FL@.300	SY	7.80	15.60	23.40
Oak look, 7 mil vinyl wear layer, 14 mm	FL@.300	SY	8.80	15.60	24.40
Tile look, 10 mil urethane wear layer, 25 mm	FL@.300	SY	9.80	15.60	25.40
Steel look, 10 mil oxide wear layer, 33 mm	FL@.300	SY	12.80	15.60	28.40
Osset rock, 7 mil infused urethane wear layer, 37 mm	FL@.300	SY	14.80	15.60	30.40
Marble look, 13 mil oxide wear layer, 25 mm	FL@.300	SY	29.40	15.60	45.00
Oak look, 7 mil metallic wear layer, 20 year guarantee	FL@.300	SY	34.50	15.60	50.10

09 Finishes

	Craft@Hrs	Unit	Material	Labor	Total
Vinyl Plank Flooring (LVP) Luxury vinyl plank and tile consists of a clear wear layer, an embossed vinyl layer, a composite core and a cushion layer. Many colors and textures available. Surface can look like wood, stone, travertine or marble. Planks are from 6" wide to 4' long and 8 mm to 12 mm thick. Floating plank is secured only at room edges with base molding. Includes 15% cutting waste.					
Most colors and textures, floating	FL@.051	SF	4.11	2.65	6.76
Premium – high traffic, waterproof, deep colors	FL@.051	SF	4.54	2.65	7.19
Armstrong Natural Creations, .125" thick	FL@.051	SF	6.69	2.65	9.34
Tread and riser, glue-down, with nosing, per stair	FL@.215	Ea	37.60	11.20	48.80
T mold strip (joins same level surface)	FL@.040	LF	5.52	2.07	7.59
Reducer strip (joins higher surface)	FL@.040	LF	4.20	2.07	6.27
End molding (joins lower surface)	FL@.040	LF	5.52	2.07	7.59
Wall base, to 4" high	FL@.040	LF	1.44	2.07	3.51
Add for floor prep, per room, typical	FL@1.50	Ea	2.14	77.80	79.94
Add for small or irregular rooms	FL@.011	SF	—	.57	.57
Add for diagonal patterns	FL@.004	SF	—	.21	.21
Plastic Interlocking Safety Floor Tiles Based on Duragrid for a 1,000 to 5,000 SF job.					
Firm, smooth tiles, for athletic courts, gym floors, industrial areas					
12" x 12" x 1/2"	F9@.003	SF	4.93	.14	5.07
2" x 12" x 1/2" line strips	F9@.003	LF	2.86	.14	3.00
Firm, non-slip (nipped) tile for tennis courts, wet-weather surfaces,					
12" x 12" x 1/2"	F9@.003	SF	4.35	.14	4.49
2" x 12" x 1/2" line strips	F9@.003	LF	2.86	.14	3.00
Soft tiles, for anti-fatigue matting, household or deck areas					
12" x 12" x 1/2"	F9@.003	SF	4.59	.14	4.73
2" x 12" x 1/2" line strips	F9@.003	LF	2.86	.14	3.00
Mitered edging strip, 2" x 12" x 1/2"	F9@.003	LF	3.01	.14	3.15
Monogramming/graphics pegs	F9@.085	C	4.82	3.98	8.80
Add for jobs under 1,000 SF	—	%	10.0	20.0	—
Deduct for jobs over 5,000 SF	—	%	-5.0	-5.0	—
Rubber Flooring and Accessories					
Rubber tile flooring					
17-13/16" x 17-13/16" x 1/8" circular pattern	F9@.021	SF	12.20	.98	13.18
Base, top set rubber, 1/8" thick					
2-1/2" high	F9@.018	LF	1.24	.84	2.08
4" high	F9@.018	LF	1.56	.84	2.40
6" high	F9@.018	LF	1.99	.84	2.83
Base corners, top set rubber, 1/8" thick					
2-1/2" or 4" high	F9@.028	Ea	1.99	1.31	3.30
6" high	F9@.028	Ea	2.51	1.31	3.82
Stair treads, molded rubber, 12-1/2" tread width, per LF of tread length					
1/4" circle design, colors	F9@.067	LF	18.80	3.13	21.93
Rib design, light duty	F9@.067	LF	20.10	3.13	23.23
Tread with abrasive strip, light duty	F9@.071	LF	22.50	3.32	25.82
Tread with abrasive strip, heavy duty	F9@.071	LF	29.20	3.32	32.52
Stair risers, molded rubber, 7" x 1/8"	F9@.038	LF	5.87	1.78	7.65
Stringer cover, 0.100", 10" high	F9@.106	LF	5.87	4.96	10.83
Add for project under 2,000 SF	F9@.010	LF	.34	.47	.81
Underlayment, plywood, 5/8"	C8@.009	SF	2.10	.43	2.53
Shock-absorbing resilient tile, rubber Installed over asphalt, concrete or compacted gravel base. Indoor or outdoor use, for playgrounds, factory floors, aerobic centers, recreational decks and docks. Unit costs below include single component polyurethane adhesive (also listed separately below). www.creativesystems.com					
2-1/4" thickness, meets CPSC guidelines for 6' drop heights					
Full tile, 24" x 24"	F9@.014	SF	12.80	.65	13.45
Diagonal tile	F9@.014	Ea	30.00	.65	30.65

09 Finishes

	Craft@Hrs	Unit	Material	Labor	Total
Transition ramp, 48" x 8"	F9@.056	Ea	36.50	2.62	39.12
Accessible ramp, 24" x 24"	F9@.056	Ea	56.80	2.62	59.42
90-degree molded outside corner 16" x 8"	F9@.112	Ea	27.80	5.24	33.04
90-degree molded inside corner 12" x 8"	F9@.110	Ea	27.40	5.14	32.54
45-degree molded outside corner 8" x 8"	F9@.110	Ea	27.10	5.14	32.24
45-degree molded inside corner 8" x 8"	F9@.109	Ea	24.60	5.10	29.70
3-3/4" thickness, meets CPSC guidelines for 11' drop heights					
Full tile, 24" x 24"	F9@.017	SF	22.00	.80	22.80
Ramp, 48" x 12"	F9@.056	Ea	85.90	2.62	88.52
Add for one part polyurethane adhesive (30 SF per gal)	—	Gal	63.60	—	63.60
Composition Flooring 1/4" thick					
Acrylic	F9@.075	SF	4.80	3.51	8.31
Epoxy terrazzo	F9@.105	SF	5.43	4.91	10.34
Conductive epoxy terrazzo	F9@.132	SF	7.54	6.17	13.71
Troweled neoprene	F9@.082	SF	6.15	3.84	9.99
Polyester	F9@.065	SF	4.10	3.04	7.14
Terrazzo					
Floors, 1/2" terrazzo topping on an underbed bonded to an existing concrete slab, over 2,000 SF job, #1 and #2 chips in gray Portland cement. Add divider strips below					
2" epoxy or polyester	T4@.128	SF	4.41	5.97	10.38
2" conductive	T4@.134	SF	5.74	6.25	11.99
2" with #3 and larger chips	T4@.134	SF	7.58	6.25	13.83
3" with 15 lb felt and sand cushion	T4@.137	SF	5.74	6.39	12.13
2-3/4" with mesh, felt and sand cushion	T4@.137	SF	5.57	6.39	11.96
Additional costs for terrazzo floors. Add for:					
White Portland cement	—	SF	.76	—	.76
Non-slip abrasive, light	—	SF	1.51	—	1.51
Non-slip abrasive, heavy	—	SF	2.32	—	2.32
Countertops, mud set	T4@.250	SF	12.80	11.70	24.50
Wainscot, precast, mud set	T4@.198	SF	12.10	9.23	21.33
Cove base, mud set	T4@.198	LF	2.95	9.23	12.18
Add for under 2,000 SF job	—	%	11.0	15.0	—
Add for under 1,000 SF job	—	%	44.0	60.0	—
Add for waterproof membrane	—	SF	1.79	—	1.79
Divider strips					
Brass, 12 gauge	T4@.009	LF	3.43	.42	3.85
White metal, 12 gauge	T4@.009	LF	1.58	.42	2.00
Brass 4' OC each way	T4@.004	SF	1.81	.19	2.00
Brass 2' OC each way	T4@.007	SF	3.49	.33	3.82
Carpeting Glue-down carpet installation includes sweeping the floor and applying adhesive. Carpet over pad installation includes laying the pad and stapling or spot adhesive.					
Nylon, cut pile, with 3/8" nova pad					
30 oz.	F9@.114	SY	18.40	5.33	23.73
36 oz.	F9@.114	SY	21.40	5.33	26.73
40 oz.	F9@.114	SY	24.30	5.33	29.63
Nylon, level loop, with 3/8" nova pad					
20 oz.	F9@.114	SY	18.40	5.33	23.73
24 oz.	F9@.114	SY	21.40	5.33	26.73
Base grade, level loop, with 50 oz. pad					
18 oz.	F9@.114	SY	9.55	5.33	14.88
20 oz.	F9@.114	SY	10.70	5.33	16.03
26 oz.	F9@.114	SY	10.70	5.33	16.03
Antron nylon, 20 oz., anti-static, no pad	F9@.068	SY	13.00	3.18	16.18
Lee's "Faculty IV" with unibond back, direct glue	F9@.114	SY	25.10	5.33	30.43

09 Finishes

	Craft@Hrs	Unit	Material	Labor	Total
Carpet Tile					
Modular carpet tiles					
"Faculty II" tiles, 26 oz face weight	F9@.170	SY	19.70	7.95	27.65
"Surfaces" tiles, 38 oz face weight	F9@.170	SY	21.00	7.95	28.95
ESD 26 oz loop pile for computer floors	F9@.170	SY	23.00	7.95	30.95
Access Flooring Standard 24" x 24" steel flooring panels with 1/8" high pressure laminate surface. Costs shown include the floor panels and the supporting understructures listed. Add for accessories below. Raised Floor Installation, Inc.					
Stringerless system, up to 10" finish floor height					
Under 1,000 SF job	D3@.058	SF	19.20	3.15	22.35
1,000 to 5,000 SF job	D3@.046	SF	16.30	2.49	18.79
Over 5,000 SF job	D3@.039	SF	14.40	2.11	16.51
Snap-on stringer system, up to 10" finish floor height					
Under 1,000 SF job	D3@.058	SF	20.90	3.15	24.05
1,000 to 5,000 SF job	D3@.046	SF	17.60	2.49	20.09
Over 5,000 SF job	D3@.039	SF	15.70	2.11	17.81
Rigid bolted stringer system, up to 18" finish floor height					
Under 1,000 SF job	D3@.058	SF	21.90	3.15	25.05
1,000 to 5,000 SF job	D3@.046	SF	18.60	2.49	21.09
Over 5,000 SF job	D3@.039	SF	16.80	2.11	18.91
Corner lock system, under 2,500 SF office areas, 6" to 10" finish floor height, blank panels					
Used flooring, most floor system types	D3@.036	SF	10.00	1.95	11.95
Unrefurbished, typical					
Refurbished, new panel surface and trim	D3@.058	SF	13.70	3.15	16.85
Refurbished, new panel surface and trim	D3@.058	SF	18.90	3.15	22.05
Extras for all floor systems, add to the costs above					
Carpeted panels	—	SF	1.89	—	1.89
Concrete-filled steel panels	—	SF	1.09	—	1.09
Ramps, per SF of actual ramp area	D3@.104	SF	11.90	5.64	17.54
Non-skid tape on ramp surface	D3@.033	SF	7.37	1.79	9.16
Portable ramp for temporary use	—	SF	81.40	—	81.40
Steps, per SF of actual tread area	D3@.208	SF	20.10	11.30	31.40
Fascia at steps and ramps, to 18" high	D3@.117	LF	13.80	6.34	20.14
Cove base, 4" high, black or brown	D3@.026	LF	2.28	1.41	3.69
Guardrail	D3@.573	LF	81.90	31.10	113.00
Handrail	D3@.573	LF	37.90	31.10	69.00
Cable cutouts					
Standard "L"-type trim	D3@.407	Ea	13.00	22.10	35.10
Type "F" trim, under floor plenum systems	D3@.407	Ea	15.10	22.10	37.20
Perforated air distribution panels					
Air distribution grilles, 6" x 18"	—	SF	5.26	—	5.26
With adjustable damper, including cutout	D3@.673	Ea	97.80	36.50	134.30
Fire extinguishing systems, smoke detectors, halon type, subcontract					
With halon gas suppression	—	SF	—	—	5.96
Automatic fire alarm	—	SF	—	—	.87
Wallcoverings Based on 2,000 SF job. These costs include 10% waste allowance. For estimating purposes, figure an average roll of wallpaper will cover 40 SF. The cost of wallpaper will vary greatly.					
Paperhanging, average quality, labor only					
Paperhanging, good quality, labor only	PA@.013	SF	—	.70	.70
Paperhanging, good quality, labor only	PA@.016	SF	—	.86	.86
Vinyl wallcovering, typical costs					
7 oz, light grade	PA@.014	SF	.52	.75	1.27
14 oz, medium grade	PA@.015	SF	.87	.81	1.68
22 oz, heavy grade, premium quality	PA@.019	SF	1.36	1.02	2.38

09 Finishes

	Craft@Hrs	Unit	Material	Labor	Total
Vinyl, 14 oz, on aluminum backer	PA@.035	SF	1.37	1.88	3.25
Flexwood, many veneers, typical job	PA@.053	SF	3.58	2.85	6.43
Cloth wallcovering					
Linen, acrylic backer, scotch guarded	PA@.021	SF	1.60	1.13	2.73
Grasscloth	PA@.021	SF	2.55	1.13	3.68
Felt	PA@.027	SF	3.22	1.45	4.67
Cork sheathing, 1/4", typical	PA@.027	SF	.73	1.45	2.18
Blank stock (underliner)	PA@.013	SF	1.33	.70	2.03
Laminated cork sheets, typical	PA@.015	SF	2.01	.81	2.82
Laminated cork sheets, colors	PA@.035	SF	2.92	1.88	4.80
Gypsum impregnated jute fabric Flexi-wall™, with #500 adhesive. Use 360 SF as minimum job size					
Medium weight plaster wall liner #605	PA@.014	SF	1.71	.75	2.46
Heavy duty plaster wall liner #609	PA@.014	SF	1.97	.75	2.72
Classics line	PA@.016	SF	2.03	.86	2.89
Images line	PA@.016	SF	2.53	.86	3.39
Trimmed paper, hand prints, foils	PA@.012	SF	1.53	.65	2.18
Add for job less than 200 SF (5 rolls)	—	%	—	20.0	—
Add for small rooms (kitchen, bath)	—	%	10.0	20.0	—
Add for patterns	—	%	—	15.0	—
Deduct for job over 2,000 SF (50 rolls)	—	%	—	-5.0	—

Vinyl Wallcovering and Borders Solid vinyl, prepasted, standard patterns and colors.

Gold floral on green	PA@.028	SF	.80	1.51	2.31
Red, green and gold	PA@.028	SF	.76	1.51	2.27
Ivy and berries	PA@.035	SF	.76	1.88	2.64
Pastel shells on sand	PA@.017	SF	.61	.91	1.52
Coordinated border	PA@.028	SF	.49	1.51	2.00

Hardboard Wallcovering Vinyl clad, printed.

3/16" pegboard	C8@.025	SF	.76	1.19	1.95
1/4" perforated white garage liner	C8@.025	SF	1.11	1.19	2.30
Add for adhesive, 1/4" bead, 16" OC	—	SF	.11	—	.11
Add for metal trim	—	LF	.57	—	.57

Decontamination and Surface Preparation Dustless removal of undesirable surface contamination and paint from steel and concrete substrates. Applications include PCBs, radioactivity, toxic chemicals and lead-based paints. The removal system is a mechanical process and no water, chemicals or abrasive grit are used. Containment or special ventilation is not required. Based on Pentek Inc. For estimating purposes figure one 55-gallon drum of contaminated waste per 2,500 square feet of coatings removed from surfaces with an average coating thickness of 12 mils. Waste disposal costs are not included. Unit prices shown are based on a crew of three. Use \$4,500 as a minimum charge for work of this type. Equipment is based on using three pneumatic needle scaler units attached to one air-powered vacuum-waste packing unit. Equipment cost includes one vacuum-waste packing unit, three needle scalers, and one 150 CFM gas or diesel powered air compressor including all hoses and connectors. Add the one-time charge for move-on, move-off and refurbishing of equipment as shown.

	Craft@Hrs	Unit	Material	Labor	Equipment	Total
--	-----------	------	----------	-------	-----------	-------

Preparation of steel surfaces to bare metal. Steel Structures Painting Council Surface Preparation (SSPC-SP) specification codes are shown

Steel surfaces, SSPC-SP-11 (coating mechanically removed, bare metal exposed)						
Overhead surfaces, box girders, obstructed areas						
30 SF of surface area per hour	PA@.100	SF	—	5.38	5.86	11.24
Large unobstructed structural steel members						
40 SF of surface area per hour	PA@.075	SF	—	4.03	4.39	8.42

09 Finishes

	Craft@Hrs	Unit	Material	Labor	Equipment	Total
Above ground storage tanks						
50 SF of surface area per hour	PA@.060	SF	—	3.23	3.52	6.75
Steel surfaces, SSPC-SP-3 (coating mechanically removed, mill scale left in place)						
Overhead surfaces, box girders, obstructed areas						
50 SF of surface area per hour	PA@.060	SF	—	3.23	3.52	6.75
Large unobstructed structural steel members						
70 SF of surface area per hour	PA@.042	SF	—	2.26	2.46	4.72
Above ground storage tanks						
90 SF of surface area per hour	PA@.033	SF	—	1.77	1.93	3.70
Door or window frames						
To 3'0" x 6'8"	PA@1.50	Ea	—	80.70	87.90	168.60
Over 3'0" x 6'8" to 6'0" x 8'0"	PA@2.00	Ea	—	108.00	117.00	225.00
Over 6'0" x 8'0" to 12'0" x 20'0"	PA@3.00	Ea	—	161.00	176.00	337.00
Preparation of concrete walls and lintels						
Concrete lintels, per SF of area	PA@.033	SF	—	1.77	1.93	3.70
Concrete walls, measured on one face of wall						
80 SF of surface area per hour	PA@.038	SF	—	2.04	2.23	4.27
Concrete block walls, measured on one face of wall						
70 SF of surface area per hour	PA@.042	SF	—	2.26	2.46	4.72
Add for mobilization, demobilization and refurbish equipment, per job	—	LS	—	—	—	3,400.00

Preparation of concrete floors and slabs

Equipment is based on using three pneumatic manually-operated wheel-mounted scabblers attached to one air-powered vacuum-waste packing unit to scarify concrete floors and slabs. Equipment cost includes one vacuum-waste packing unit, three scabblers, and one 150 CFM gas or diesel powered air compressor including all hoses and connectors. Add the one-time charge for move-on, move-off and refurbishing of equipment as shown.

Large unobstructed areas; warehouses and aircraft hanger floor slabs						
90 SF of surface area per hour	PA@.033	SF	—	1.77	2.11	3.88
Obstructed areas; narrow aisles, areas in pits						
60 SF of surface area per hour	PA@.050	SF	—	2.69	3.20	5.89
Small areas; around equipment, piping and conduit						
40 SF of surface area per hour	PA@.075	SF	—	4.03	4.81	8.84
Add for mobilization, demobilization and refurbish equipment	—	LS	—	—	—	4,450.00

Painting labor costs — commercial and industrial work Painting costs in this section assume work can be done from the floor or from ladders. Add the cost of scaffolding or staging when if required. Painting costs in this section include no surface preparation and no masking or protection of adjacent surfaces. Estimates for surface preparation and protection of adjacent surfaces are shown separately below. For more complete information on commercial and industrial painting costs, see *National Painting Cost Estimator* at <https://craftsman-book.com/national-estimator-cloud>.

	Craft@Hrs	Unit	Material	Labor	Total
Preparing metals for painting. SSPC is Steel Structures Painting Council.					
Brush, scrape, sand by hand (SSPC-2), 50 SF per hour	PA@.020	SF	—	1.08	1.08
Power tool cleaning (SSPC-3), 100 SF per hour	PA@.010	SF	—	.54	.54
Pressure washing (SSPC-12), 500 SF per hour	PA@.002	SF	—	.11	.11
Steam cleaning, 330 SF per hour	PA@.003	SF	—	.16	.16
Structural metals, machinery or equipment, paint one coat					
Brush work, light to medium coating	PA@.006	SF	—	.32	.32
Brush work, heavy coat	PA@.007	SF	—	.38	.38
Mitt, or glove, light to medium coating	PA@.007	SF	—	.38	.38

09 Finishes

	Craft@Hrs	Unit	Material	Labor	Total
Roll, heavy coating	PA@.003	SF	—	.16	.16
Spray light or medium coat	PA@.002	SF	—	.11	.11
Spray heavy coat	PA@.003	SF	—	.16	.16
Spray machinery or equipment	PA@.003	SF	—	.16	.16
Exterior metals, paint one coat					
Brush metal siding	PA@.006	SF	—	.32	.32
Roll metal siding	PA@.003	SF	—	.16	.16
Spray metal siding	PA@.002	SF	—	.11	.11
Spray metal decking	PA@.003	SF	—	.16	.16
Brush metal trim	PA@.004	SF	—	.22	.22
Spray chain link fencing	PA@.003	SF	—	.16	.16
Pipe or HVAC duct, paint one coat. Consider each linear foot of conduit under 4" in diameter as having one square foot of surface regardless of the pipe diameter. Consider each valve as having 2 square feet of surface regardless of the size.					
Brush, no insulation	PA@.007	SF	—	.38	.38
Brush, with insulation	PA@.006	SF	—	.32	.32
Roll, mitt or glove, no insulation	PA@.005	SF	—	.27	.27
Roll, mitt or glove, with insulation	PA@.007	SF	—	.38	.38
Spray pipe or small ductwork	PA@.003	SF	—	.16	.16
Spray larger ductwork	PA@.003	SF	—	.16	.16
Conduit, hangers or fasteners, paint one coat					
Brush application	PA@.007	SF	—	.38	.38
Mitt or glove application	PA@.006	SF	—	.32	.32
Spray application	PA@.003	SF	—	.16	.16
Exterior metals coated with a single coat of epoxy or mastic, 8 to 10 mil film					
Brush epoxy coating	PA@.016	SF	—	.86	.86
Roll epoxy coating	PA@.006	SF	—	.32	.32
Spray epoxy coating	PA@.004	SF	—	.22	.22
Brush mastic coating	PA@.019	SF	—	1.02	1.02
Roll mastic coating	PA@.008	SF	—	.43	.43
Spray mastic coating	PA@.005	SF	—	.27	.27
Interior metals, paint one coat					
Spray joists and decking	PA@.003	SF	—	.16	.16
Brush hollow metal items	PA@.013	SF	—	.70	.70
Roll hollow metal items	PA@.006	SF	—	.32	.32
Spray hollow metal items	PA@.006	SF	—	.32	.32
Tanks or spheres, paint one coat					
Roll the exterior shell	PA@.004	SF	—	.22	.22
Roll the exterior roof	PA@.004	SF	—	.22	.22
Spray the exterior shell	PA@.003	SF	—	.16	.16
Spray the exterior roof	PA@.003	SF	—	.16	.16
Surface preparation for masonry or concrete					
Acid etching, 250 SF per hour	PA@.004	SF	—	.22	.22
Water blasting, 110 SF per hour	PA@.009	SF	—	.48	.48
Paint concrete, one coat					
Roll tilt up walls	PA@.004	SF	—	.22	.22
Spray tilt up walls	PA@.003	SF	—	.16	.16
Roll stucco walls	PA@.005	SF	—	.27	.27
Spray stucco walls	PA@.003	SF	—	.16	.16
Roll form-poured concrete walls	PA@.004	SF	—	.22	.22
Spray form-poured concrete walls	PA@.003	SF	—	.16	.16
Brush elastomeric or mastic, walls	PA@.019	SF	—	1.02	1.02

09 Finishes

	Craft@Hrs	Unit	Material	Labor	Total
Roll elastomeric or mastic, walls	PA@.008	SF	—	.43	.43
Spray elastomeric or mastic, walls	PA@.005	SF	—	.27	.27
Brush epoxy coating on walls	PA@.014	SF	—	.75	.75
Roll epoxy coating on walls	PA@.007	SF	—	.38	.38
Spray epoxy coating on walls	PA@.005	SF	—	.27	.27
Roll ceiling	PA@.005	SF	—	.27	.27
Spray ceiling	PA@.003	SF	—	.16	.16
Spray concrete deck	PA@.003	SF	—	.16	.16
Brush concrete floor or steps	PA@.006	SF	—	.32	.32
Roll concrete floor or steps	PA@.005	SF	—	.27	.27
Masonry walls, paint one coat					
Brush concrete block	PA@.008	SF	—	.43	.43
Roll concrete block	PA@.004	SF	—	.22	.22
Spray concrete block	PA@.003	SF	—	.16	.16
Roll scored concrete block or brick	PA@.008	SF	—	.43	.43
Spray scored concrete block or brick	PA@.004	SF	—	.22	.22
Spray fluted masonry	PA@.006	SF	—	.32	.32
Brush block filler	PA@.019	SF	—	1.02	1.02
Roll block filler	PA@.008	SF	—	.43	.43
Spray block filler	PA@.005	SF	—	.27	.27
Swimming pool paint, elastomerics and mastics					
Brush application	PA@.008	SF	—	.43	.43
Roller application	PA@.005	SF	—	.27	.27
Spray application	PA@.003	SF	—	.16	.16
Polyurethane epoxy floor system					
Etch and neutralize concrete	PA@.006	SF	.03	.32	.35
Roll base coat	PA@.006	SF	.08	.32	.40
Roll first flood coat	PA@.006	SF	.12	.32	.44
Apply chip coat, by hand	PA@.003	SF	.06	.16	.22
Sanding and wiping, by machine	PA@.003	SF	.02	.16	.18
Roll second flood coat	PA@.002	SF	.12	.11	.23
Roll first finish glaze coat	PA@.002	SF	.12	.11	.23
Roll second finish glaze coat	PA@.002	SF	.08	.11	.19
Roll third finish glaze coat	PA@.002	SF	.08	.11	.19
Total cost poly-epoxy floor system	PA@.032	SF	.71	1.72	2.43
Wood floors and decks, paint one coat					
Brush porch floor	PA@.006	SF	—	.32	.32
Roll or spray porch floor	PA@.005	SF	—	.27	.27
Brush wood steps, risers and stringers	PA@.008	SF	—	.43	.43
Brush rail or baluster, per LF of rail or baluster	PA@.008	LF	—	.43	.43
Brush large post	PA@.010	SF	—	.54	.54
Shingles or siding, paint one coat					
Brush shingles or rough siding	PA@.010	SF	—	.54	.54
Roll shingles or rough siding	PA@.006	SF	—	.32	.32
Spray shingles or rough siding	PA@.003	SF	—	.16	.16
Brush mineral fiber shingles	PA@.010	SF	—	.54	.54
Roll mineral fiber shingles	PA@.008	SF	—	.43	.43
Spray mineral fiber shingles	PA@.003	SF	—	.16	.16
Brush shake siding	PA@.010	SF	—	.54	.54
Spray shake siding	PA@.006	SF	—	.32	.32
Brush rustic or lap siding	PA@.009	SF	—	.48	.48
Roll rustic or lap siding	PA@.007	SF	—	.38	.38
Spray rustic or lap siding	PA@.004	SF	—	.22	.22
Roll board and batten siding	PA@.006	SF	—	.32	.32

09 Finishes

	Craft@Hrs	Unit	Material	Labor	Total
Spray board and batten siding	PA@.003	SF	—	.16	.16
Roll smooth siding	PA@.004	SF	—	.22	.22
Spray smooth siding	PA@.003	SF	—	.16	.16
Preparing interior surfaces for painting					
Lay and secure drop cloth, 1,300 SF per hour	PA@.078	CSF	.14	4.19	4.33
Masking with paper, 75 LF per hour	PA@.013	LF	.06	.70	.76
Cover up with plastic or paper, 3,200 SF per hour	PA@.031	CSF	.04	1.67	1.71
Light sanding of wood trim, 75 SF per hour	PA@.013	LF	.05	.70	.75
Wire brush surface, 100 SF per hour	PA@.010	SF	.05	.54	.59
Sand paneling, 110 SF per hour	PA@.009	SF	.05	.48	.53
Light hand wash, 250 SF per hour	PA@.004	SF	.03	.22	.25
Remove calcimine, 125 SF per hour	PA@.008	SF	.06	.43	.49
Interior walls, paint one coat					
Brush smooth plaster or drywall, 165 SF per hour	PA@.006	SF	—	.32	.32
Roll smooth plaster or drywall, 250 SF per hour	PA@.004	SF	—	.22	.22
Spray smooth plaster or drywall, 515 SF per hour	PA@.002	SF	—	.11	.11
Roll sand finish plaster or drywall, 250 SF per hour	PA@.004	SF	—	.22	.22
Spray sand finish plaster or drywall, 325 SF per hour	PA@.003	SF	—	.16	.16
Roll rough sand finish wall, 200 SF per hour	PA@.005	SF	—	.27	.27
Spray rough sand finish wall, 325 SF per hour	PA@.003	SF	—	.16	.16
Brush wood paneling, 165 SF per hour	PA@.006	SF	—	.32	.32
Spray wood paneling, 325 SF per hour	PA@.003	SF	—	.16	.16
Interior ceilings, paint one coat					
Roll acoustical ceiling, 140 SF per hour	PA@.007	SF	—	.38	.38
Spray acoustical ceiling, 250 SF per hour	PA@.004	SF	—	.22	.22
Roll acoustical metal pan ceiling, 250 SF per hour	PA@.004	SF	—	.22	.22
Spray acoustical metal pan ceiling, 525 SF per hour	PA@.002	SF	—	.11	.11
Roll smooth drywall ceiling, 250 SF per hour	PA@.004	SF	—	.22	.22
Spray smooth drywall ceiling, 325 SF per hour	PA@.003	SF	—	.16	.16
Spray open wood or ceiling, 325 SF per hour	PA@.003	SF	—	.16	.16
Roll tongue and groove ceiling, 200 SF per hour	PA@.005	SF	—	.27	.27
Spray tongue and groove ceiling, 325 SF per hour	PA@.003	SF	—	.16	.16
Cabinets or shelving, paint one coat					
Brush one coat, 125 SF per hour	PA@.008	SF	—	.43	.43
Spray one coat, 165 SF per hour	PA@.006	SF	—	.32	.32

Material cost for painting Cost per coat based on purchase in gallon quantities. Paint coverage per gallon is based on second and later coats applied by roller or brush. Add 10% for first coats. Add 20% when paint is applied with a sprayer.

Acrylic deck and siding stain 350 SF per gallon	—	SF	.11	—	.11
Penetrating tinted natural stain 250 SF per gallon	—	SF	.15	—	.15
Oil-based wiping stain 225 SF per gallon	—	SF	.14	—	.14
Water-based urethane exterior clear finish 400 SF per gallon	—	SF	.11	—	.11
Oil-based urethane interior clear finish 400 SF per gallon	—	SF	.14	—	.14
Interior latex primer 400 SF per gallon	—	SF	.06	—	.06
Interior flat latex 400 SF per gallon	—	SF	.06	—	.06

09 Finishes

	Craft@Hrs	Unit	Material	Labor	Total
Interior latex gloss enamel 400 SF per gallon	—	SF	.11	—	.11
Exterior oil-based primer-sealer 350 SF per gallon	—	SF	.07	—	.07
Concrete and masonry bonding epoxy primer 350 SF per gallon	—	SF	.06	—	.06
Exterior flat acrylic latex primer-sealer 350 SF per gallon	—	SF	.12	—	.12
Exterior gloss acrylic latex primer-sealer 350 SF per gallon	—	SF	.13	—	.13
Rust preventative metal primer, 3 mil dry film thickness 300 SF per gallon	—	SF	.13	—	.13
Oil-based industrial enamel 300 SF per gallon	—	SF	.15	—	.15
Chlorinated rubber swimming pool paint 350 SF per gallon	—	SF	.20	—	.20
Waterborne epoxy architectural gloss coating 350 SF per gallon	—	SF	.16	—	.16

10 Specialties

Chalkboards, Whiteboards, and Tackboards

Chalkboard with aluminum frame, full-length chalk rail 4' x 6' to 4' x 12'	CC@.034	SF	12.20	1.82	14.02
Chalkboard with oak frame, full-length chalk rail 4' x 6' to 4' x 16'	CC@.034	SF	11.80	1.82	13.62
Melamine whiteboard with aluminum frame and tray 4' x 3'	CC@.408	Ea	57.00	21.80	78.80
5' x 3'	CC@.510	Ea	121.00	27.30	148.30
5' x 4'	CC@.680	Ea	129.00	36.40	165.40
6' x 4'	CC@.816	Ea	149.00	43.70	192.70
8' x 4'	CC@1.22	Ea	178.00	65.30	243.30
10' x 4'	CC@1.36	Ea	286.00	72.80	358.80
12' x 4'	CC@1.63	Ea	289.00	87.30	376.30
Melamine whiteboard with wood frame and tray 4' x 3'	CC@.408	Ea	65.00	21.80	86.80
5' x 3'	CC@.510	Ea	139.00	27.30	166.30
5' x 4'	CC@.680	Ea	159.00	36.40	195.40
6' x 4'	CC@.816	Ea	158.00	43.70	201.70
8' x 4'	CC@1.22	Ea	194.00	65.30	259.30
Porcelain on steel markerboard, aluminum frame and tray 4' x 3'	CC@.408	Ea	197.00	21.80	218.80
5' x 3'	CC@.510	Ea	176.00	27.30	203.30
5' x 4'	CC@.680	Ea	277.00	36.40	313.40
6' x 4'	CC@.816	Ea	289.00	43.70	332.70
8' x 4'	CC@1.09	Ea	336.00	58.30	394.30
10' x 4'	CC@1.36	Ea	477.00	72.80	549.80
12' x 4'	CC@1.63	Ea	569.00	87.30	656.30
Porcelain on steel markerboard, wood frame and tray 4' x 3'	CC@.408	Ea	209.00	21.80	230.80
5' x 3'	CC@.510	Ea	318.00	27.30	345.30
5' x 4'	CC@.680	Ea	362.00	36.40	398.40
8' x 4'	CC@.816	Ea	559.00	43.70	602.70

10 Specialties

	Craft@Hrs	Unit	Material	Labor	Total
Natural corkboard with aluminum frame and tray					
5' x 3'	CC@.510	Ea	103.00	27.30	130.30
5' x 4'	CC@.680	Ea	112.00	36.40	148.40
6' x 4'	CC@.816	Ea	126.00	43.70	169.70
8' x 4'	CC@1.09	Ea	176.00	58.30	234.30
10' x 4'	CC@1.36	Ea	216.00	72.80	288.80
12' x 4'	CC@1.63	Ea	257.00	87.30	344.30
Identifying Devices					
Directory boards, felt-covered changeable letter boards, indoor mount					
Open faced, aluminum frame					
18" x 2', 1 door	C8@.635	Ea	205.00	30.20	235.20
2' x 3', 1 door	C8@1.31	Ea	291.00	62.40	353.40
4' x 3', 2 doors	C8@1.91	Ea	445.00	90.90	535.90
Open faced, wood frame					
18" x 2', 1 door	C8@.635	Ea	175.00	30.20	205.20
2' x 3', 1 door	C8@1.31	Ea	235.00	62.40	297.40
4' x 3', 2 doors	C8@1.91	Ea	355.00	90.90	445.90
Acrylic door, aluminum frame					
18" x 2', 1 door	C8@.635	Ea	449.00	30.20	479.20
2' x 3', 1 door	C8@1.31	Ea	640.00	62.40	702.40
4' x 3', 2 doors	C8@1.91	Ea	1,190.00	90.90	1,280.90
Hand-painted lettering, typical subcontract prices					
Standard, per square foot	—	SF	—	—	27.40
Gold leaf, per square foot	—	SF	—	—	53.50
Architectural signage, engraved, self-adhesive plastic signs with high contrast white lettering					
4" x 12", stock wording	PA@.191	Ea	38.00	10.30	48.30
4" x 12", custom wording	PA@.191	Ea	45.00	10.30	55.30
3" x 8", stock wording	PA@.191	Ea	35.00	10.30	45.30
3" x 8", custom wording	PA@.191	Ea	40.00	10.30	50.30
Add for aluminum mounting frame					
4" x 12"	PA@.096	Ea	28.50	5.16	33.66
3" x 8"	PA@.096	Ea	17.90	5.16	23.06
LED illuminated letters, porcelain enamel finish, stock letters, aluminum with Plexiglas face, add electrical work					
12" high x 2-1/2" wide, 1 tube per letter	C8@.849	Ea	206.00	40.40	246.40
24" high x 5" wide, 2 tubes per letter	C8@1.61	Ea	386.00	76.60	462.60
30" high x 5" wide, 2 tubes per letter	C8@3.28	Ea	585.00	156.00	741.00
Fabricated back-lighted letters, aluminum with LED illumination, baked enamel finish, script, add electrical work					
12" high x 3" deep, 1 tube	G1@.834	Ea	89.70	40.70	130.40
18" high x 6" deep, 2 tubes	G1@1.41	Ea	140.00	68.90	208.90
24" high x 8" deep, 2 tubes	G1@2.53	Ea	248.00	124.00	372.00
Cast aluminum letters, various styles, for use on building interior or exterior					
4" high	C8@.215	Ea	31.00	10.20	41.20
8" high	C8@.320	Ea	57.00	15.20	72.20
12" high	C8@.320	Ea	83.00	15.20	98.20
15" high	C8@.456	Ea	141.00	21.70	162.70
18" high	C8@.456	Ea	175.00	21.70	196.70
24" high	C8@.456	Ea	314.00	21.70	335.70
Deduct for injection molded plastic letters	—	%	-50.0	—	—
Add for cast bronze letters	—	%	106.0	—	—

10 Specialties

	Craft@Hrs	Unit	Material	Labor	Total
Braille signage, meets ADA and CABO/ANSI A117.1 requirements, various colors, interior (See ADA section)					
8" x 8"	PA@.250	Ea	82.80	13.40	96.20
2" x 8"	PA@.250	Ea	47.90	13.40	61.30
Plaques, including standard lettering, expansion or toggle bolt applied					
Aluminum, cast 12" x 4"	G1@.900	Ea	154.00	44.00	198.00
Aluminum, cast 24" x 18"	G1@2.70	Ea	898.00	132.00	1,030.00
Aluminum, cast 24" x 36"	G1@2.91	Ea	1,400.00	142.00	1,542.00
Bronze, cast 12" x 4"	G1@.900	Ea	230.00	44.00	274.00
Bronze, cast 24" x 18"	G1@2.70	Ea	1,480.00	132.00	1,612.00
Bronze, cast 24" x 36"	G1@2.91	Ea	2,960.00	142.00	3,102.00
Safety and warning signs, stock signs ("High Voltage", "Fire Exit", etc.). Indoor, high performance plastic					
10" x 7"	PA@.099	Ea	31.00	5.32	36.32
14" x 10"	PA@.099	Ea	46.00	5.32	51.32
24" x 18"	PA@.099	Ea	127.00	5.32	132.32
Add for aluminum	—	%	46.6	—	—
Vandal-resistant 14" x 10"	PA@.099	Ea	39.60	5.32	44.92
Indoor, pressure sensitive vinyl signs					
10" x 7" or 14" x 10"	PA@.099	Ea	21.80	5.32	27.12
Compartments and Cubicles					
Toilet partitions, floor mounted. Standard sizes, include 1 panel, 1 door and all pilasters and hardware.					
Powder coated metal	T5@2.66	Ea	616.00	137.00	753.00
Solid plastic (polymer)	T5@4.00	Ea	1,200.00	206.00	1,406.00
Laminated plastic	T5@2.66	Ea	692.00	137.00	829.00
Stainless steel	T5@2.66	Ea	1,350.00	137.00	1,487.00
Add for wheel chair units	—	Ea	70.30	—	70.30
Add for ceiling hung units	T5@.500	Ea	30.10	25.70	55.80
Add for free-standing units (no adjacent wall)	T5@.900	Ea	178.00	46.30	224.30
Urinal screens, wall mounted with brackets, 18" wide by 48" high.					
Standard quality, powder coated	T5@1.95	Ea	123.00	100.00	223.00
Solid plastic (polymer)	T5@1.50	Ea	153.00	77.20	230.20
Laminated plastic	T5@1.03	Ea	96.00	53.00	149.00
Stainless steel	T5@1.03	Ea	282.00	53.00	335.00
Add for floor mounted, 24" wide	T5@.476	Ea	40.90	24.50	65.40
Accessories mounted on partitions					
Coat hooks and door stop, chrome	T5@.166	Ea	10.90	8.54	19.44
Purse shelf, chrome, 5" x 14"	T5@.166	Ea	107.00	8.54	115.54
Dressing cubicles, 80" high, with curtain, floor mounted, overhead braced					
Powder coated steel	T5@3.41	Ea	410.00	175.00	585.00
Solid plastic (polymer)	T5@4.52	Ea	733.00	233.00	966.00
Laminated plastic	T5@3.41	Ea	456.00	175.00	631.00
Stainless steel	T5@3.41	Ea	814.00	175.00	989.00
Shower compartments, industrial type, with receptor but no door or plumbing					
Powder coated steel	T5@2.68	Ea	1,060.00	138.00	1,198.00
Solid plastic (polymer)	T5@4.04	Ea	1,430.00	208.00	1,638.00
Laminated plastic	T5@2.68	Ea	1,100.00	138.00	1,238.00
Stainless steel	T5@2.68	Ea	2,030.00	138.00	2,168.00
Add for soap dish	T5@.166	Ea	11.20	8.54	19.74
Add for curtain rod	T5@.166	Ea	7.83	8.54	16.37
Doors for industrial shower compartments					
Wire or tempered glass, 24" x 72"	G1@1.03	Ea	121.00	50.30	171.30
Plastic, 24" x 72"	G1@1.03	Ea	80.70	50.30	131.00
Plastic, 1 panel door and 1 side panel	G1@1.03	Ea	164.00	50.30	214.30

10 Specialties

	Craft@Hrs	Unit	Material	Labor	Total
Shower stalls, with receptor, 32" x 32", with door but no plumbing					
Fiberglass	P6@2.65	Ea	322.00	140.00	462.00
Painted metal	P6@2.65	Ea	357.00	140.00	497.00
Hospital cubicle curtain track, ceiling mount	MW@.060	LF	7.07	3.26	10.33

Movable Office Partitions Prefabricated units. Cost per SF of partition wall measured one side. Use 100 SF as minimum job size.

Gypsum board on 2-1/2" metal studs (includes finish on both sides)					
1/2" board, unpainted, STC 38	C8@.028	SF	8.52	1.33	9.85
5/8" board, unpainted, STC 40	C8@.028	SF	8.69	1.33	10.02
1/2" or 5/8", unpainted, STC 45	C8@.028	SF	9.57	1.33	10.90
1/2" vinyl-covered board, STC 38	C8@.028	SF	10.30	1.33	11.63
5/8" vinyl-covered board, STC 40	C8@.028	SF	10.80	1.33	12.13
Metal-covered, baked enamel finish	C8@.028	SF	22.50	1.33	23.83
Add for factory vinyl wrap, 15 to 22 oz	—	SF	.83	—	.83
Windows, including frame and glass, add to above, factory installed					
3'6" x 2'0"	—	Ea	102.00	—	102.00
3'6" x 4'0"	—	Ea	150.00	—	150.00
Wood doors, hollow core, prefinished, add to above, factory installed					
1-3/4", 3'0" x 7'0"	—	Ea	417.00	—	417.00
Additional costs for gypsum board partitions					
Metal door jambs, 3'6" x 7'0"	—	Ea	249.00	—	249.00
Metal door jambs, 6'0" x 7'0"	—	Ea	418.00	—	418.00
Passage hardware set	—	Ea	84.80	—	84.40
Lockset hardware	—	LS	117.00	—	117.00
Corner for gypsum partitions	—	Ea	125.00	—	125.00
Corner for metal-covered partitions	—	Ea	244.00	—	244.00
Starter, gypsum partitions	—	Ea	42.10	—	42.10
Starter, metal-covered partitions	—	Ea	88.70	—	88.70
Metal floor base	—	LF	2.51	—	2.51
Cubicles and welded booths, 5' x 5' x 5'	C8@.028	SF	14.30	1.33	15.63
Banker type divider partition, subcontract					
5'6" high including 18" glass top, 2" thick, vinyl finish, not including door or gates	—	SF	—	—	14.90

Demountable Partitions Prefinished units. Cost per SF of partition measured one side. Use 100 SF as minimum job size. Labor shown applies to installing or removing.

Modular panels, spring pressure, mounted to floor and ceiling with removable tracks

Standard panel, non-rated	C8@.124	SF	29.90	5.90	35.80
---------------------------	---------	----	-------	------	-------

Accordion Folding Partitions

Vinyl-covered particleboard core, top hung, including structural supports and track. STC = Sound Transmission Coefficient.

Economy, to 8' high, STC 36	—	SF	21.60	—	21.60
Economy, to 30' wide x 17' high, STC 41	—	SF	29.80	—	29.80
Good quality, to 30' W x 17' H, STC 43	—	SF	35.10	—	35.10
Better quality, to 30' W x 17' H, STC 44	—	SF	36.00	—	36.00
Better quality, large openings, STC 45	—	SF	33.60	—	33.60
Better quality, extra large openings, STC 47	—	SF	36.00	—	36.00
Installation of folding partitions, per LF of track	C8@.647	LF	—	30.80	30.80
Add for prefinished birch or ash wood slats accordion folding partitions					
With vinyl hinges, 15' W x 8' H maximum	—	SF	14.30	—	14.30

10 Specialties

	Craft@Hrs	Unit	Material	Labor	Total
Folding fire partitions, accordion, with automatic closing system, baked enamel finish, with standard hardware and motor, cost per 5' x 7' module					
20 minute rating	C8@22.6	Ea	7,400.00	1,080.00	8,480.00
60 minute rating	C8@22.6	Ea	9,400.00	1,080.00	10,480.00
90 minute rating	C8@22.6	Ea	10,100.00	1,080.00	11,180.00
2 hour rating	C8@22.6	Ea	11,900.00	1,080.00	12,980.00
Folding leaf partitions, typical subcontract prices. Not including header or floor track recess, vinyl covered.					
Metal panels, 7.5 lbs per SF, top hung, hinged, (STC 52), 16' high x 60' wide maximum	—	SF	—	—	72.30
Metal panels, 7.5 lbs per SF, top hung, single panel pivot, (STC 48), 18' high x 60' wide maximum	—	SF	—	—	73.60
Wood panels, hinged, floor or ceiling hung, 6 lbs per SF, (STC 40), 12' high x 36' wide maximum	—	SF	—	—	59.60
Add for laminated plastic	—	SF	—	—	3.34
Add for unfinished wood veneer	—	SF	—	—	4.02
Add for chalkboard, large area	—	SF	—	—	3.24
Woven Wire Partitions 10 gauge painted, 1-1/2" steel mesh.					
Wall panels, 8' high, installed on a concrete slab					
1' wide	H6@.437	Ea	181.00	23.70	204.70
2' wide	H6@.491	Ea	212.00	26.60	238.60
3' wide	H6@.545	Ea	241.00	29.50	270.50
4' wide	H6@.545	Ea	275.00	29.50	304.50
5' wide	H6@.598	Ea	279.00	32.40	311.40
Add for galvanized mesh	—	SF	1.18	—	1.15
Corner posts for 8' high walls	H6@.270	Ea	62.60	14.60	77.20
Stiffener channel posts for 8' walls	H6@.277	Ea	123.00	15.00	138.00
Service window panel, 8' H x 5' W panel	H6@.836	Ea	594.00	45.30	639.30
Sliding doors, 8' high wall, 7' H door with 1' transom					
3' wide	H6@2.94	Ea	939.00	159.00	1,098.00
4' wide	H6@3.29	Ea	986.00	178.00	1,164.00
5' wide	H6@3.29	Ea	1,050.00	178.00	1,228.00
6' wide	H6@3.58	Ea	1,240.00	194.00	1,434.00
Hinged doors, 8' high wall, 7' H door with 1' transom					
3' wide	H6@2.85	Ea	731.00	154.00	885.00
4' wide	H6@3.14	Ea	835.00	170.00	1,005.00
Dutch doors, 8' high					
3' wide	H6@2.85	Ea	1,140.00	154.00	1,294.00
4' wide	H6@3.14	Ea	1,280.00	170.00	1,450.00
Complete wire partition installation including posts and typical doors, per SF of wall and ceiling panel					
Painted wall panels	H6@.029	SF	7.85	1.57	9.42
Galvanized wall panels	H6@.029	SF	9.01	1.57	10.58
Painted ceiling panels	H6@.059	SF	7.28	3.19	10.47
Galvanized ceiling panels	H6@.059	SF	8.23	3.19	11.42
Wall Protection Systems .063" extruded aluminum retainer with a .100" extruded plastic (Acrovyn) cover. Installed with adhesive or mechanical fasteners over existing drywall, doors or door frames. No substrate costs are included.					
Flush-mounted corner guards, 3" x 3" wide legs	CC@.194	LF	14.90	10.40	25.30
Surface-mounted corner guards, 3" x 3" wide legs	CC@.069	LF	8.42	3.69	12.11
Handrail	CC@.111	LF	16.70	5.94	22.64
Bumper guards, bed bumpers	CC@.138	LF	11.30	7.39	18.69
Door frame protectors	CC@.056	LF	16.90	3.00	19.90
Door protectors	CC@.083	SF	5.42	4.44	9.86
Protective wallcovering (vinyl only)	PA@.087	SF	4.24	4.68	8.92

10 Specialties

	Unit	Commercial Industrial Grade	Institutional Grade
Toilet and Bath Accessories Material cost only. See labor following this section.			
Combination towel and waste units			
Recessed paper towel dispenser	Ea	214.00	267.00
Recessed roll towel dispenser	Ea	381.00	585.00
Surface paper towel dispenser	Ea	61.20	107.00
Surface mounted roll towel dispenser	Ea	234.00	354.00
Recessed roll towel dispenser with waste bin	Ea	614.00	716.00
Recessed paper towel dispenser with waste bin	Ea	170.00	506.00
Waste receptacles			
Recessed, 12 gallon	Ea	223.00	267.00
Surface mounted	Ea	86.10	211.00
Floor standing	Ea	178.00	290.00
Countertop chute	Ea	118.00	240.00
Wall urns			
Recessed	Ea	174.00	201.00
Surface mounted	Ea	114.00	156.00
Floor standing with waste	Ea	—	187.00
Sanitary napkin dispenser, recessed	Ea	284.00	574.00
Soap dispensers			
Liquid, 20 oz, lavatory mounted	Ea	44.70	49.40
Liquid, 34 oz, lavatory mounted	Ea	51.40	57.70
Powder	Ea	47.40	66.10
Under-counter reservoir system, with 3 stations	Ea	—	1,270.00
Add for additional stations	Ea	—	108.00
Liquid, surface mounted	Ea	20.90	44.70
Powdered, surface mounted	Ea	16.60	103.00
Toilet paper dispensers			
Multi roll, recessed	Ea	88.80	132.00
Multi roll, surface mounted	Ea	68.70	104.00
Toilet seat cover dispensers			
Recessed	Ea	77.50	137.00
Surfaced mounted	Ea	40.00	57.40
Soap dishes			
With grab bar, recessed	Ea	26.50	33.00
With grab bar, surface mounted	Ea	42.80	53.00
Grab bars, stainless steel, wall mounted			
1-1/2" x 12"	Ea	—	30.20
1-1/2" x 18"	Ea	—	28.80
1-1/2" x 24"	Ea	—	33.00
1-1/2" x 30"	Ea	—	34.60
1-1/2" x 36"	Ea	—	35.50
1-1/2" x 48"	Ea	—	38.80
1-1/4" x 18"	Ea	—	68.70
1-1/4" x 24"	Ea	—	74.50
1-1/4" x 36"	Ea	—	91.80
1", 90 degree angle, 30"	Ea	—	107.00
1-1/4", 90 degree angle, 30"	Ea	—	132.00
Towel bars			
18" chrome	Ea	—	47.40
24" chrome	Ea	—	49.00
18" stainless steel	Ea	—	50.10
24" stainless steel	Ea	—	53.10

10 Specialties

	Unit	Commercial Industrial Grade	Institutional Grade			
Medicine cabinets, with mirror						
Swing door, 16" x 22", wall hung	Ea	89.60	343.00			
Swing door, 16" x 22", recessed	Ea	105.00	293.00			
Mirrors, unframed, polished stainless steel back						
16" x 20"	Ea	58.60	—			
16" x 24"	Ea	66.60	—			
18" x 24"	Ea	70.80	—			
18" x 30"	Ea	84.30	—			
24" x 30"	Ea	109.00	—			
24" x 36"	Ea	137.00	—			
Mirrors, stainless steel frame, 1/4" glass						
16" x 24"	Ea	—	51.90			
18" x 24"	Ea	—	55.00			
18" x 30"	Ea	—	66.00			
18" x 36"	Ea	—	86.40			
24" x 30"	Ea	—	91.00			
24" x 36"	Ea	—	107.00			
24" x 48"	Ea	—	132.00			
24" x 60"	Ea	—	186.00			
72" x 36"	Ea	—	317.00			
Shelves, stainless steel, 6" deep						
18" long	Ea	63.80	73.90			
24" long	Ea	66.70	76.70			
36" long	Ea	85.70	98.40			
72" long	Ea	135.00	184.00			
Shower rod, end flanges, vinyl curtain						
6' long, straight	Ea	67.20	83.70			
Robe hooks						
Single	Ea	9.68	14.30			
Double	Ea	11.80	15.90			
Single with door stop	Ea	11.00	18.10			
Straddle bar, stainless steel						
24" x 24" x 20"	Ea	143.00	167.00			
Urinal bar, 24" long, stainless steel	Ea	116.00	138.00			
Hot air hand dryer, 115 volt						
add electric connection	Ea	216.00	575.00			
	Craft@Hrs	Unit	Material	Labor	Total	
Labor to install toilet and bath accessories						
Toilet paper dispensers						
Surface mounted	CC@.182	Ea	—	9.74	9.74	
Recessed	CC@.310	Ea	—	16.60	16.60	
Toilet seat cover dispensers						
Surface mounted	CC@.413	Ea	—	22.10	22.10	
Recessed	CC@.662	Ea	—	35.40	35.40	
Feminine napkin dispenser, surface mounted	CC@.760	Ea	—	40.70	40.70	
Feminine napkin dispenser, recessed	CC@.882	Ea	—	47.20	47.20	
Soap dishes	CC@.230	Ea	—	12.30	12.30	
Soap dispensers, surface mounted	CC@.254	Ea	—	13.60	13.60	
Soap dispensers, recessed	CC@.628	Ea	—	33.60	33.60	
Soap dispenser system	CC@2.91	Ea	—	156.00	156.00	
Paper towel dispensers and waste receptacles						
Semi-recessed	CC@1.96	Ea	—	105.00	105.00	
Recessed	CC@2.57	Ea	—	138.00	138.00	
Medicine cabinets with mirror, swing door						
Wall hung	CC@.943	Ea	—	50.50	50.50	

10 Specialties

	Craft@Hrs	Unit	Material	Labor	Total
Mirrors					
To 5 SF	CG@.566	Ea	—	31.70	31.70
5 to 10 SF	CG@.999	Ea	—	56.00	56.00
Over 10 SF	CG@.125	SF	—	7.01	7.01
Towel bars and grab bars	CC@.286	Ea	—	15.30	15.30
Shelves, stainless steel, to 72"	CC@.569	Ea	—	30.50	30.50
Robe hooks	CC@.182	Ea	—	9.74	9.74
Hot air hand dryer, add for electric circuit wiring	CE@.908	Ea	—	55.40	55.40
Baby Changing Stations Polyethylene or stainless steel with steel on steel hinges. Holds up to 350 lbs. Changing stations require 22" horizontal wall space. Costs include sanitary bed liner dispenser, safety straps, necessary hardware and metal door plaques.					
Polyethylene					
Horizontal baby changing station, surface mount, 20" H x 35" W	CL@.750	Ea	213.00	31.20	244.20
Add for recess mount with stainless steel flange	CL@1.25	Ea	835.00	52.10	887.10
Vertical baby changing station, surface mount, 36" H x 22" W	CL@.750	Ea	291.00	31.20	322.20
Stainless steel					
Horizontal baby changing station, surface mount, 20" H x 35" W	CL@.750	Ea	1,500.00	31.20	1,531.20
Horizontal baby changing station, recessed mount, 23" H x 37" W	CL@1.25	Ea	1,900.00	52.10	1,952.10
Add for sanitary bed liners, pack of 500	—	Ea	48.60	—	48.60
Add for changing stations replacement strap	—	Ea	13.00	—	13.00
Add for changing stations sign, plastic, 7" x 5"	—	Ea	11.00	—	11.00
Child Protection Seat Polyethylene with steel on steel hinges. Holds up to 150 lbs. Requires 19 square inches wall space. Costs include safety straps and necessary hardware.					
Child protection seat, 19" H x 12" W	CL@.550	Ea	204.00	22.90	226.90
Add for replacement safety strap	—	Ea	13.00	—	13.00
Lockers, Metal Baked enamel finish, key lock 12" wide x 60" high x 15" deep overall dimensions					
Single tier, cost per locker	D4@.571	Ea	150.00	27.40	177.40
Double tier, cost per 2 lockers	D4@.571	Ea	143.00	27.40	170.40
Five tier, cost per 5 lockers	D4@.571	Ea	152.00	27.40	179.40
Six tier, cost per 6 lockers	D4@.571	Ea	201.00	27.40	228.40
Add for 72" height	—	%	10.0	—	—
Add for 15" width	—	%	25.0	—	—
Subtract for unassembled	—	%	-20.0	—	—
Postal Specialties					
Letter boxes, cost per each, recessed mounted					
Aluminum					
15" x 19" private access	D4@1.10	Ea	280.00	52.80	332.80
15" x 19" USPS access	D4@1.10	Ea	250.00	52.80	302.80
Brass					
15" x 19" private access	D4@1.10	Ea	290.00	52.80	342.80
15" x 19" USPS access	D4@1.10	Ea	256.00	52.80	308.80
Brass indoor mailboxes for private use. Solid brass die-cast doors with lock, 1/4" glass window and name plate					
Rear loading 30 door unit, 3-1/2" W x 5" H door	C8@1.10	Ea	950.00	52.40	1,002.40
Rear loading 14 door unit, 3-1/2" W x 5" H door	C8@1.00	Ea	938.00	47.60	985.60
Add for front loading unit	—	%	20.0	—	—
Aluminum rack ladder system, private use, 1/4" extruded aluminum doors. 20 gauge cold rolled steel compartments, open back. Unit dimensions 23-1/4" W x 12-1/8" H x 15-1/2" D					
Rear loading 12 door unit, 3-1/2" W x 5-1/2" H door	C8@1.50	Ea	300.00	71.40	371.40
Rear loading 8 door unit, 5-1/2" W x 5-1/2" H door	C8@1.50	Ea	295.00	71.40	366.40
Rear loading 4 door unit, 10-3/4" W x 5-1/2" H door	C8@1.50	Ea	285.00	71.40	356.40
Rack ladder, 61-7/8" H x 15-1/2" D	C8@.500	Ea	100.00	23.80	123.80
Steel rotary mail center, 30" W x 74" H x 24" D	C8@1.00	Ea	1,350.00	47.60	1,397.60



10 Specialties

	Craft@Hrs	Unit	Material	Labor	Total
Vertical mailboxes, aluminum, USPS approved, surface mounted or recessed. Door size 5-1/2" W x 15-3/4" H, front loading					
7 door unit, 40-3/4" W x 19-1/2" H x 7-1/4" D	C8@1.00	Ea	560.00	47.60	607.60
5 door unit, 29-3/4" W x 19-1/2" H x 7-1/4" D	C8@1.00	Ea	400.00	47.60	447.60
3 door unit, 18-3/4" W x 19-1/2" H x 7-1/4" D	C8@1.00	Ea	240.00	47.60	287.60
Pedestal mailboxes, aluminum neighborhood delivery and collection box units with weather protection hood. USPS approved, rear access. Doors are 6-3/8" W x 5-1/4" H					
16 door unit, 26-1/2" W x 22-1/2" H x 22" D	C8@1.10	Ea	1,980.00	52.40	2,032.40
12 door unit, 20" W x 22-1/2" H x 22" D	C8@1.10	Ea	1,900.00	52.40	1,952.40
32" replacement pedestal	C8@1.00	Ea	150.00	47.60	197.60
Storage Shelving					
Retail store gondolas (supermarket shelving units), material prices vary widely, check local source					
Install only	D4@.333	LF	—	16.00	16.00
Steel industrial shelving, enamel finish, 2 sides & back, 12" deep x 30" wide x 75" high					
5 shelves high	D4@.758	Ea	137.00	36.40	173.40
8 shelves high	D4@1.21	Ea	189.00	58.10	247.10
Steel industrial shelving, enamel finish, open on sides, 12" deep x 36" wide x 75" high					
5 shelves high	D4@.686	Ea	79.70	32.90	112.60
8 shelves high	D4@1.06	Ea	121.00	50.90	171.90
Stainless steel modular shelving, 20" deep x 36" wide x 63" high					
3 shelves, 16 gauge	D4@1.19	Ea	1,340.00	57.20	1,397.20
Stainless steel wall shelf, 12" deep, bracket mount					
	D4@.675	LF	61.30	32.40	93.70
Stainless steel work counters, with under-counter storage shelf, 16 gauge					
4' wide x 2' deep x 3' high	D4@1.36	Ea	1,440.00	65.30	1,505.30
6' wide x 2' deep x 3' high	D4@2.01	Ea	2,180.00	96.50	2,276.50
Library type metal shelving, 90" high, 8" deep, 5 shelves					
30" long units	D4@1.17	Ea	239.00	56.20	295.20
36" long units	D4@1.30	Ea	257.00	62.40	319.40
Flagpoles Including erection cost but no pre-mixed concrete. See foundation costs below. Costs also include all hardware required. By pole height above ground, except as noted. Buried dimension is usually 10% of pole height. Costs include typical shipping cost.					
Fiberglass, tapered, external halyard, commercial grade, with hardware and ground sleeve, white					
25' high	D4@8.19	Ea	1,430.00	393.00	1,823.00
30' high	D4@9.21	Ea	1,590.00	442.00	2,032.00
35' high	D4@9.96	Ea	2,080.00	478.00	2,558.00
40' high	D4@10.2	Ea	2,510.00	490.00	3,000.00
50' high	D4@15.1	Ea	6,360.00	725.00	7,085.00
60' high	D4@18.5	Ea	6,650.00	889.00	7,539.00
70' high	D4@21.7	Ea	14,900.00	1,040.00	15,940.00
Aluminum, satin finish, tapered, external halyard, sectional, architectural grade					
20' high	D4@8.19	Ea	1,430.00	393.00	1,823.00
25' high	D4@8.19	Ea	1,770.00	393.00	2,163.00
30' high	D4@9.21	Ea	1,950.00	442.00	2,392.00
35' high	D4@9.96	Ea	2,620.00	478.00	3,098.00
40' high	D4@10.2	Ea	3,320.00	490.00	3,810.00
45' high	D4@10.5	Ea	3,840.00	504.00	4,344.00
50' high	D4@15.1	Ea	5,220.00	725.00	5,945.00
60' high	D4@18.5	Ea	10,100.00	889.00	10,989.00
70' high	D4@21.7	Ea	11,300.00	1,040.00	12,340.00
80' high	D4@25.2	Ea	14,200.00	1,210.00	15,410.00

10 Specialties

	Craft@Hrs	Unit	Material	Labor	Total
Additional costs for tapered aluminum flagpoles					
Add for nautical yardarm mast	—	%	20.0	—	—
Add for internal halyard (vandal resistant)	—	%	20.0	—	—
Add for clear finish	—	%	15.0	—	—
Add for bronze finish	—	%	20.0	—	—
Add for black finish	—	%	30.0	—	—
Wall-mounted aluminum poles, including wall mount on concrete or masonry structure					
8' high	D4@7.95	Ea	426.00	382.00	808.00
10' high	D4@9.69	Ea	443.00	465.00	908.00
17' with wall support, vertical	D4@11.1	Ea	448.00	533.00	981.00
20' with wall support, vertical	D4@14.4	Ea	455.00	692.00	1,147.00
Add for yardarm nautical mast					
6'6" aluminum yardarm	—	Ea	1,040.00	—	1,040.00
13'6" aluminum yardarm	—	Ea	1,010.00	—	1,010.00
Add for eagle mounted on spindle rod					
10" H gold finish, 24" wingspan	—	Ea	215.00	—	215.00
12" H gold finish, 11" wingspan	—	Ea	116.00	—	116.00
18" H gold finish, 15" wingspan	—	Ea	126.00	—	126.00
Poured concrete flagpole foundations with sand fill, including typical excavation. Metal collar, steel casing, base plate, sand fill and ground spike costs are included with the pole above. By pole height above ground.					
30' high or less	P9@10.5	Ea	70.70	515.00	585.70
35' high	P9@10.8	Ea	108.00	529.00	637.00
40' high	P9@12.5	Ea	120.00	613.00	733.00
45' high	P9@13.2	Ea	172.00	647.00	819.00
50' high	P9@15.8	Ea	293.00	774.00	1,067.00
60' high	P9@19.2	Ea	491.00	941.00	1,432.00
70' high	P9@22.5	Ea	561.00	1,100.00	1,661.00
80' high	P9@26.0	Ea	858.00	1,270.00	2,128.00
90' to 100' high	P9@30.1	Ea	603.00	1,480.00	2,083.00
Direct embedded pole base, augered in place, no concrete required, by pole height					
20' to 25' pole	D4@1.88	Ea	566.00	90.30	656.30
25' to 40' pole	D4@2.71	Ea	810.00	130.00	940.00
45' to 55' pole	D4@2.99	Ea	911.00	144.00	1,055.00
60' to 70' pole	D4@3.42	Ea	1,010.00	164.00	1,174.00

11 Equipment

Service Station Equipment These costs do not include excavation, concrete work, piping or electrical work					
Air compressor, 1-1/2 HP with receiver	PF@5.54	Ea	2,470.00	349.00	2,819.00
Air compressor, 3 HP with receiver	PF@5.54	Ea	2,940.00	349.00	3,289.00
Hose reels with hose					
Air hose, 50', heavy duty	PF@8.99	Ea	1,240.00	567.00	1,807.00
Water hose, 50' and valve	PF@8.01	Ea	1,260.00	505.00	1,765.00
Lube rack, 3 hose, remote pump	PF@48.4	Ea	7,050.00	3,050.00	10,100.00
Lube rack, 5 hose, remote pump	PF@48.4	Ea	13,000.00	3,050.00	16,050.00
Air-operated pumps for hose reels, fit 55 gallon drum					
Motor oil or gear oil	PF@1.00	Ea	1,250.00	63.10	1,313.10
Lube oil	PF@1.00	Ea	2,610.00	63.10	2,673.10
Gasoline dispensers, commercial type, two-sided display, add the cost of hose and fill nozzles.					
Mechanical display, single product, one hose, low cabinet, standard suction pump	PF@9.94	Ea	5,430.00	627.00	6,057.00
Electronic display, two product, two hose, low cabinet, standard suction pump	PF@9.94	Ea	8,080.00	627.00	8,707.00

11 Equipment

	Craft@Hrs	Unit	Material	Labor	Total
Electronic display, three product, four hose, high cabinet, PCI-compliant card payment terminal	PF@9.94	Ea	10,100.00	627.00	10,727.00
Remote control station, connects up to 16 dispensers to a point of sale terminal, add the cost of wire and conduit	PF@4.00	Ea	1,960.00	252.00	2,212.00
Vapor recovery fill nozzle, 8' hose with breakaway fitting, per hose and nozzle	PF@1.00	LS	40.90	63.10	104.00
Air and water service, post type with auto-inflator and retracting hoses, hoses included	PF@9.58	Ea	2,350.00	604.00	2,954.00
Add for electric thermal unit, factory installed	—	Ea	140.00	—	140.00
Auto hoist. Prices vary with the rating and capacity					
Hoist, single post frame contact 8,000 lb semi hydraulic	D4@71.3	Ea	4,940.00	3,420.00	8,360.00
Hoist, single post frame contact 8,000 lb fully hydraulic	D4@71.3	Ea	5,300.00	3,420.00	8,720.00
Hoist, two post, pneumatic, 11,000 lb	D4@114.	Ea	9,630.00	5,480.00	15,110.00
Hoist, two post, pneumatic, 24,000 lb	D4@188.	Ea	13,300.00	9,030.00	22,330.00
Two-post fully hydraulic hoists. Prices vary with the rating and capacity					
11,000 lb capacity	D4@188.	Ea	8,510.00	9,030.00	17,540.00
13,000 lb capacity	D4@188.	Ea	8,650.00	9,030.00	17,680.00
18,500 lb capacity	D4@188.	Ea	11,700.00	9,030.00	20,730.00
24,000 lb capacity	D4@188.	Ea	15,600.00	9,030.00	24,630.00
26,000 lb capacity	D4@188.	Ea	16,900.00	9,030.00	25,930.00
Cash box and pedestal stand	D4@2.55	Ea	393.00	122.00	515.00
Tire changer, 120 PSI pneumatic, auto tire	D4@10.6	Ea	3,840.00	509.00	4,349.00
Tire changer, hydraulic, truck tire	D4@21.4	Ea	11,900.00	1,030.00	12,930.00
Exhaust fume system, underground, complete Per station	D5@9.52	Ea	816.00	495.00	1,311.00
Parking Control Equipment Costs are for parking equipment only, no concrete work, paving, or electrical work included. Labor costs include installation and testing.					
Parking gates, controllable by attendant, vehicle detector, ticket dispenser, card reader, or coin/token machine					
Barrier gate operator with 10' arm	D4@9.13	Ea	2,480.00	439.00	2,919.00
Barrier gate operator with 14' arm	D4@9.13	Ea	2,550.00	439.00	2,989.00
Barrier gate operator with counter-balanced arm	D4@9.13	Ea	4,540.00	439.00	4,979.00
Heavy-duty swing gate opener	D4@9.13	Ea	2,030.00	439.00	2,469.00
1/2 HP commercial slide gate opener	D4@9.13	Ea	3,990.00	439.00	4,429.00
Add for battery backup	—	Ea	603.00	—	603.00
Vehicle detector, for installation in approach lane, including cutting and grouting	D4@4.96	Ea	476.00	238.00	714.00
Ticket dispenser (spitter), with date/time imprinter actuated by vehicle detector or hand button	D4@9.13	Ea	7,000.00	439.00	7,439.00
Card readers					
Non-programmable, parking areas with long-term parking privileges Per station	D4@3.39	Ea	727.00	163.00	890.00
Programmable, parking areas for users paying a fee to renew parking privileges Per reader	D4@3.39	Ea	5,650.00	163.00	5,813.00
Access controls, keypad type					
Wall, post or gooseneck mounting, weatherproof	D4@1.00	Ea	185.00	48.00	233.00
Lane spikes, dragon teeth, installation includes cutting and grouting as needed					
6' wide, surface-mounted	D4@6.69	Ea	1,630.00	321.00	1,951.00
6' wide, flush-mounted	D4@9.69	Ea	1,520.00	465.00	1,985.00
Lighted warning sign for lane spikes	D4@5.71	Ea	762.00	274.00	1,036.00

11 Equipment

	Craft@Hrs	Unit	Material	Labor	Equipment	Total
Loading Dock Equipment Costs shown assume that equipment is set in prepared locations. No excavation, concrete work or electrical work included. Equipment cost is for a 4,000 lb. forklift. Move equipment on or off job						
Allow, per move	—	LS	—	—	170.00	170.00
Dock levelers, Systems, Inc.						
Edge-of-dock leveler, manual	D6@2.25	Ea	3,580.00	125.00	26.40	3,731.40
Mechanical platform dock leveler, recessed, 25,000 lb. capacity						
6' wide x 6' long	D6@3.00	Ea	5,350.00	167.00	35.20	5,552.20
6' wide x 8' long	D6@3.00	Ea	5,750.00	167.00	35.20	5,952.20
6' wide x 10' long	D6@3.00	Ea	7,630.00	167.00	35.20	7,832.20
7' wide x 8' long	D6@3.00	Ea	6,640.00	167.00	35.20	6,842.20
Hydraulic, pit type						
6' wide x 6' long	D6@4.50	Ea	7,100.00	250.00	52.90	7,402.90
6' wide x 8' long	D6@4.50	Ea	7,500.00	250.00	52.90	7,802.90
Dock seals, foam pad type, 12" projection, with anchor brackets (bolts not included), door opening size as shown, Systems, Inc.						
8' wide x 8' high, standard duty	D6@3.75	Ea	982.00	208.00	44.10	1,234.10
8' wide x 10' high, heavy duty	D6@3.75	Ea	1,100.00	208.00	44.10	1,352.10
Dock lifts, portable, electro-hydraulic scissor lifts, Systems, Inc.						
4,000 lb. capacity, 6' x 6' dock	D6@2.25	Ea	15,100.00	125.00	26.40	15,251.40
Dock lifts, pit recessed, electro-hydraulic scissor lifts, Advance Lifts						
5,000 lb. capacity, 6' x 8' platform	D6@12.0	Ea	11,700.00	666.00	141.00	12,507.00
6,000 lb. capacity, 6' x 8' platform	D6@12.0	Ea	13,600.00	666.00	141.00	14,407.00
8,000 lb. capacity						
6' x 8' platform	D6@12.0	Ea	22,700.00	666.00	141.00	23,507.00
8' x 10' platform	D6@12.0	Ea	25,400.00	666.00	141.00	26,207.00
10,000 lb. capacity						
6' x 10' platform	D6@12.0	Ea	29,700.00	666.00	141.00	30,507.00
8' x 10' platform	D6@12.0	Ea	31,700.00	666.00	141.00	32,507.00
12,000 lb. capacity						
6' x 10' platform	D6@15.0	Ea	33,600.00	833.00	176.00	34,609.00
8' x 12' platform	D6@15.0	Ea	38,600.00	833.00	176.00	39,609.00
16,000 lb. capacity						
6' x 10' platform	D6@15.0	Ea	37,300.00	833.00	176.00	38,309.00
8' x 12' platform	D6@15.0	Ea	42,300.00	833.00	176.00	43,309.00
20,000 lb. capacity						
6' x 12' platform	D6@15.0	Ea	41,300.00	833.00	176.00	42,309.00
8' x 12' platform	D6@15.0	Ea	45,800.00	833.00	176.00	46,809.00
Combination dock lift and dock leveler, electro-hydraulic scissor lifts, pit recessed, 5,000 lb. capacity, Advance Lifts						
6' x 7'2" platform	D6@12.0	Ea	15,800.00	666.00	141.00	16,607.00
6' x 8' platform	D6@12.0	Ea	12,800.00	666.00	141.00	13,607.00
Dock bumpers, laminated rubber, add the cost of masonry anchors						
10" high x 18" wide x 4-1/2" thick	D4@.248	Ea	90.40	11.90	—	102.30
10" high x 24" wide x 4-1/2" thick	D4@.299	Ea	116.00	14.40	—	130.40
10" high x 36" wide x 4-1/2" thick	D4@.269	Ea	173.00	12.90	—	185.90
10" high x 24" wide x 6" thick	D4@.358	Ea	151.00	17.20	—	168.20
10" high x 36" wide x 6" thick	D4@.416	Ea	223.00	20.00	—	243.00

11 Equipment

	Craft@Hrs	Unit	Material	Labor	Equipment	Total
20" high x 11" wide x 4-1/2" thick	D4@.499	Ea	108.00	24.00	—	132.00
20" high x 11" wide x 6" thick	D4@.259	Ea	151.00	12.40	—	163.40
12" high x 24" wide x 4-1/2" thick	D4@.328	Ea	142.00	15.80	—	157.80
12" high x 36" wide x 4-1/2" thick	D4@.432	Ea	212.00	20.70	—	232.70
Add for 4 masonry anchors	D4@1.19	LS	3.33	57.20	—	60.53
Barrier posts, 8' long concrete-filled steel posts set 4' underground in concrete						
3" diameter	P8@.498	Ea	128.00	23.30	—	151.30
4" diameter	P8@.498	Ea	180.00	23.30	—	203.30
6" diameter	P8@.752	Ea	230.00	35.20	—	265.20
8" diameter	P8@1.00	Ea	277.00	46.80	—	323.80
Loading dock shelter, fabric covered, steel frame,						
24" extension for 10' x 10' door	D4@9.91	Ea	1,140.00	476.00	—	1,616.00
Perimeter door seal,						
12" x 12", vinyl cover	D4@.400	LF	32.60	19.20	—	51.80

	Craft@Hrs	Unit	Material	Labor	Equipment	Total
--	-----------	------	----------	-------	-----------	-------

Truck Scales Fully electronic pit-type steel-deck scales. Add the cost of the concrete pit box, electrical service and excavation.

35 ton, 8' x 10' axle scale	D4@112.	Ea	8,960.00	5,380.00	—	14,340.00
50 ton, 10' x 90' truck scale	D4@167.	Ea	49,600.00	8,020.00	—	57,620.00

Turnstiles

Access control turnstiles, 3' high						
Non-register type, manual	D4@2.78	Ea	941.00	134.00	—	1,075.00
Register type, manual	D4@2.78	Ea	1,350.00	134.00	—	1,484.00
Add for coin, token, card or electronic control	—	Ea	337.00	—	—	337.00
Register type, portable	—	Ea	2,050.00	—	—	2,050.00
Security-type rotary turnstiles, 7'0" high, indoor or outdoor						
Free access, Type B (vertical bar outer cage)	D4@15.6	Ea	6,930.00	749.00	—	7,679.00
One way, Type B (vertical bar outer cage)	D4@15.6	Ea	7,560.00	749.00	—	8,309.00
Free access, Type AA (horizontal bar outer cage)	D4@18.4	Ea	9,020.00	884.00	—	9,904.00
One way, Type AA (horizontal bar outer cage)	D4@18.4	Ea	9,890.00	884.00	—	10,774.00
Add for electric control	—	Ea	777.00	—	—	777.00

Recessed Floor Safes Safes with 1" thick steel door, 1/4" hardplate protecting locking mechanism, welded deadbolts, key or combination lock and internal relock device.

In-floor safes						
15" L x 16" W x 11" D, floor safe	D4@2.33	Ea	702.00	112.00	—	814.00
15" L x 16" W x 22" D, floor safe	D4@2.33	Ea	935.00	112.00	—	1,047.00
25" L x 25" W x 17" D, floor safe	D4@2.33	Ea	1,280.00	112.00	—	1,392.00
14" L x 14" W x 4" D, wall safe	D4@2.00	Ea	636.00	96.10	—	732.10
14" L x 14" W x 11" D, wall safe	D4@2.00	Ea	930.00	96.10	—	1,026.10
Add for installation in existing building	D4@2.00	Ea	—	96.10	—	96.10

	Craft@Hrs	Unit	Material	Labor	Equipment	Total
--	-----------	------	----------	-------	-----------	-------

Bank Equipment

Fire-rated vault doors, 80" high. 18 bolt. 2300 degree. Installed with a 20-ton hydraulic crane. Add the cost of delivery.						
30" wide, 2 hour rating	D4@11.9	Ea	3,490.00	572.00	672.00	4,734.00
35" wide, 2 hour rating	D4@16.4	Ea	4,090.00	788.00	926.00	5,804.00
40" wide, 2 hour rating	D4@20.8	Ea	4,600.00	999.00	1,180.00	6,779.00
35" wide, 4 hour rating	D4@16.4	Ea	5,650.00	788.00	926.00	7,364.00
40" wide, 4 hour rating	D4@20.8	Ea	6,610.00	999.00	1,180.00	8,789.00

11 Equipment

	Craft@Hrs	Unit	Material	Labor	Equipment	Total
Teller transaction windows						
Drive-up, motorized drawer, projected	D4@26.8	Ea	8,100.00	1,290.00	—	9,390.00
Transaction window, 24" x 36"	D4@17.6	Ea	1,600.00	845.00	—	2,445.00
Transaction window, 36" x 36"	D4@17.6	Ea	1,800.00	845.00	—	2,645.00
Add for amplified speak-thru	—	Ea	1,280.00	—	—	1,280.00
After-hours depository doors.						
Envelope and bag, whole chest, complete	D4@37.1	Ea	6,560.00	1,780.00	—	8,340.00
Envelope only	D4@4.72	Ea	1,440.00	227.00	—	1,667.00
Flush-mounted, bag only	D4@5.44	Ea	2,000.00	261.00	—	2,261.00
Teller counter, modular components						
Square check desks, 48" x 48", 4 person	C8@2.00	Ea	1,750.00	95.20	—	1,845.20
Round check desks, 48" diameter, 4 person	C8@2.00	Ea	1,920.00	95.20	—	2,015.20
Rectangular check desks, 72" x 24", 4 person	C8@2.00	Ea	1,640.00	95.20	—	1,735.20
Rectangular check desks, 36" x 72", 8 person	C8@2.00	Ea	3,190.00	95.20	—	3,285.20
Bank partition, bullet resistant, 2.5" thick	C8@.093	SF	55.20	4.43	—	59.63
Safe deposit boxes, modular units.						
18 openings, 2" x 5"	D4@3.42	Ea	1,890.00	164.00	—	2,054.00
30 openings, 2" x 5"	D4@3.42	Ea	2,390.00	164.00	—	2,554.00
42 openings, 2" x 5"	D4@3.42	Ea	3,070.00	164.00	—	3,234.00
Base, 32" x 24" x 3"	D4@1.11	Ea	182.00	53.30	—	235.30
Canopy top	D4@.857	Ea	104.30	41.20	—	145.50
Cash dispensing automatic teller	CE@84.3	Ea	42,500.00	5,140.00	—	47,640.00
Video camera surveillance system, 3 cameras	CE@15.6	Ea	3,380.00	952.00	—	4,332.00
Perimeter alarm system, typical cost	CE@57.7	Ea	8,440.00	3,520.00	—	11,960.00

	Craft@Hrs	Unit	Material	Labor	Total
--	-----------	------	----------	-------	-------

Checkroom Equipment

Automatic electric checkroom conveyor, 350 coat capacity						
Conveyor and controls	D4@15.2	Ea	6,070.00	730.00	—	6,800.00
Add for 1 shelf	—	Ea	1,320.00	—	—	1,320.00
Add for electrical connection for checkroom conveyor, typical subcontract price						
40' wire run with conduit, circuit breaker, and junction box	—	LS	—	—	—	505.00

Coat and Hat Racks Assembly and installation of prefabricated coat and hat racks. Wall-mounted coat and hat rack with pilfer-resistant hangers, aluminum

24" length, 8 hangers	CC@.665	Ea	173.00	35.60	—	208.60
36" length, 12 hangers	CC@.748	Ea	203.00	40.00	—	243.00
48" length, 16 hangers	CC@.833	Ea	302.00	44.60	—	346.60
60" length, 20 hangers	CC@.916	Ea	330.00	49.00	—	379.00
72" length, 24 hangers	CC@.997	Ea	355.00	53.40	—	408.40

Food Service Equipment These costs do not include electrical work or plumbing. Add the cost of hookup when needed. (Figure in parentheses is equipment weight.)

Food stations, vinyl clad steel, with stainless steel work area and clear acrylic breath/sneeze guard, 24" D x 35" H, mounted on 4" casters						
Hot food station, 60" long (182 lbs)	D4@1.00	Ea	3,420.00	48.00	—	3,468.00
Hot food station, 46" long (156 lbs)	D4@1.00	Ea	2,920.00	48.00	—	2,968.00
Cold food station, 60" long (166 lbs)	D4@1.00	Ea	2,750.00	48.00	—	2,798.00
Cold food station, 46" long (147 lbs)	D4@1.00	Ea	2,480.00	48.00	—	2,528.00
Plate rest with mounting kit (10 lbs)	D4@.250	Ea	551.00	12.00	—	563.00
Incandescent light assembly (20 lbs)	D4@.250	Ea	855.00	12.00	—	867.00

11 Equipment

	Craft@Hrs	Unit	Material	Labor	Total
Food warmers, stainless steel top, hardwood cutting board, 12" x 20" openings, waterless					
58-1/2", gas, 4 openings (135 lbs)	P6@1.00	Ea	1,610.00	52.90	1,662.90
58-1/2", electric, 3,000 watt, 4 openings, (135 lbs)	E4@1.00	Ea	1,770.00	51.30	1,821.30
Convection countertop one-compartment steamer, stainless steel. Holds multiple pan inserts. Thermostatically controlled					
208 volt electric heater element. Holds 12" x 20" x 2-1/2" deep pans. Underwriters Laboratories and NSF listed.					
Add the cost of 3/4" water valve connection and 2" drain valve connection.					
3-pan inserts, 8.1 KW	P1@16.0	Ea	11,100.00	596.00	11,696.00
5-pan inserts, 11 KW	P1@20.0	Ea	15,600.00	744.00	16,344.00
Meat and deli case, self-contained with gravity cooling, stainless steel top, 54" high x 34" deep					
48-1/2" long (425 lbs)	D4@3.00	Ea	4,800.00	144.00	4,944.00
72-1/2" long (595 lbs)	D4@4.00	Ea	6,010.00	192.00	6,202.00
Freestanding bench type meat saw, 5/8" saw blade, belt-drive, toggle switch, 9.56" x 10.3" throat size. Includes a wheel and blade scraper, stainless steel carriage table with easy-slide moving height and a hose down cleanable epoxy enamel cabinet. 1.5 HP motor. Grade 304 stainless steel throughout. Underwriters Laboratories and NSF rated.					
14" x 14" table	D4@2.00	Ea	2,620.00	96.10	2,716.10
24" x 24" table	D4@2.00	Ea	4,600.00	96.10	4,696.10
Sandwich preparation units, free standing, stainless steel top, sides and back, 115 V AC, refrigerated 30" D x 43" H, full length 12" deep cutting board					
6.5 cubic feet, 27-1/2" long	D4@2.00	Ea	1,500.00	96.10	1,596.10
12 cubic feet, 48" long	D4@2.00	Ea	2,230.00	96.10	2,326.10
Pizza preparation units, free standing, stainless steel top, sides and back, 115 V AC, refrigerated 35-1/2" D x 41-1/2" H, full length 19-1/2" deep cutting board					
11.4 cubic feet, 44-1/2" long, one door	D4@2.00	Ea	3,590.00	96.10	3,686.10
20.6 cubic feet, 67" long, two doors	D4@2.00	Ea	5,120.00	96.10	5,216.10
30.9 cubic feet, 93-1/4" long, three doors	D4@2.00	Ea	6,930.00	96.10	7,026.10
Pan kit for prep tables	—	Ea	99.40	—	99.40
Sushi serving table, custom made with multiple sealed wells for wet or dry operation. Grade 304 stainless steel with understorage, 14 gauge base supports, individual drains and valves and adjustable legs. White polyethylene top, glass customer product screen and cutting board. Thermostatically controlled electric heater elements. Add for customer seating. Underwriters Laboratories and NSF rated.					
5-customer seating	T5@40.0	Ea	14,500.00	2,060.00	16,560.00
10-customer seating	T5@75.0	Ea	31,300.00	3,860.00	35,160.00
Four-station ice cream and shake serving and dispenser, heat-treatment freezer system type, multiple quart per station capacity, with syrup dispensers, product pumps, water valve connections, cleaning drain connections, thermostatic controls, product digital temperature and serve rate metering. Grade 304 stainless steel throughout. Underwriters Laboratories and NSF rated. Add the cost of forklift equipment rental if necessary.					
14 quart total capacity	D4@30.0	Ea	31,100.00	1,440.00	32,540.00
28 quart total capacity	D4@30.0	Ea	47,200.00	1,440.00	48,640.00
Shelving, aluminum, free-standing, 2,000 lb. capacity lower shelf, 400 lb capacity uppers					
18" x 36" x 68" high, 3 tier	C8@2.00	Ea	354.00	95.20	449.20
18" x 48" x 68" high, 3 tier	C8@2.00	Ea	390.00	95.20	485.20
18" x 36" x 76" high, 4 tier	C8@2.00	Ea	443.00	95.20	538.20
18" x 48" x 76" high, 4 tier	C8@2.00	Ea	481.00	95.20	576.20
Work tables, 16 gauge type 430 stainless steel, 30" high. Includes two 12" deep over-shelves, full depth under-shelf and pot and ladle rack.					
48" long (118 lbs.)	D4@1.00	Ea	1,220.00	48.00	1,268.00
60" long (135 lbs.)	D4@1.00	Ea	1,340.00	48.00	1,388.00
72" long (154 lbs.)	D4@1.00	Ea	1,400.00	48.00	1,448.00
Add to any work table above					
20" x 20" x 5" pull flange drawer (13 lbs.)	D4@.250	Ea	126.00	12.00	138.00
Stainless steel pot hooks	—	Ea	13.90	—	13.90

11 Equipment

	Craft@Hrs	Unit	Material	Labor	Total
Exhaust hoods, 16 gauge grade 304 stainless steel with #3 polished finish. Conforms to NFPA code #96 and the National Sanitation Foundation requirements. Add for exhaust fans from the next section.					
48" deep angled front hood, 24" high with length as listed below					
6' long (205 lbs.)	T5@2.00	Ea	1,430.00	103.00	1,533.00
8' long (250 lbs.)	T5@3.00	Ea	1,860.00	154.00	2,014.00
10' long (285 lbs.)	T5@4.00	Ea	2,290.00	206.00	2,496.00
Additives to any hood above					
Installation kit	—	Ea	247.00	—	247.00
Grease filters, aluminum, cleanable, 2' deep	T5@.125	LF	51.70	6.43	58.13
Exhaust fans, 2,800 CFM, 1,265 RPM. Wall- or roof-mounted, for use with the exhaust hoods above. Heavy duty aluminum with 115 volt AC motor in a weathertight enclosure.					
These costs are based on installing the fan in an existing opening, add the cost of electrical hookup					
Fan for 6' long hood, 18-1/2" square curb size					
1/2 HP (75 lbs.)	T5@2.00	Ea	1,300.00	103.00	1,403.00
Fan for 8' or 10' long hood, 23-1/2" square curb size					
1/2 HP (100 lbs.)	T5@2.00	Ea	1,370.00	103.00	1,473.00
Additives to either fan above					
Roof curb	T5@1.00	Ea	373.00	51.50	424.50
Variable speed motor controller, 115 volt AC	—	Ea	171.00	—	171.00
Lights, incandescent, pre-wired, 115 volt AC	—	Ea	103.00	—	103.00
Ductwork, aluminized steel	T5@.100	LF	44.10	5.15	49.25
90-degree elbow for ductwork, aluminized steel	T5@.500	Ea	293.00	25.70	318.70
Electrostatic precipitators for restaurant exhaust air purification. Removes kitchen exhaust grease, smoke and odors. Meets EPA, state and most local air quality standards. Multi-stage, self-contained filtration unit with electrostatic precipitator ionizer module, 95% DOP (dioctyl phthalate) Mil-Std 282 media filter, and carbon modules for odor control. For applications in commercial and institutional kitchens such as restaurants, food courts, hospitals, and schools.					
1,200 CFM, 1.5 Amperes	P1@16.0	Ea	9,470.00	596.00	10,066.00
2,400 CFM, 5.0 Amperes	P1@20.0	Ea	13,400.00	744.00	14,144.00
Removable oven and stove exhaust hood filters with mounting flue enclosure. Seamless welded design, finished in marine-grade 316 stainless steel, 27" deep hood, with internal blower meeting Home Ventilating Institute certified performance standards. Fully enclosed with baffle filters, halogen lamps, marine grade controls to resist high moisture and heat in flue gases. With backsplash panel and soffit flue venting. Commercial and institutional grade. NSF and NFPA and Underwriters Laboratories approved.					
1,100 CFM	P6@20.0	Ea	5,480.00	1,060.00	6,540.00
1,200 CFM	P6@20.0	Ea	7,910.00	1,060.00	8,970.00
1,500 CFM	P6@20.0	Ea	8,530.00	1,060.00	9,590.00
Restaurant cooking area fire protection wet chemical system. Exceeds Underwriters Laboratories standards (UL-300, Fire Extinguishing Systems for Protection of Restaurant Cooking Areas) and complies with NFPA 17A (Wet Chemical Extinguishing Systems), NFPA 96 (Commercial Cooking Operations, Ventilation Control and Fire) and major insurance company guidelines.					
5' wide range hood	P6@16.0	Ea	2,280.00	847.00	3,127.00
12' wide range hood	P6@24.0	Ea	3,250.00	1,270.00	4,520.00
Charbroiler, radiant, countertop model, burner and control every 12", natural or LP gas					
80,000 Btu, 24" W (155 lbs.)	P6@2.00	Ea	2,970.00	106.00	3,076.00
120,000 Btu, 36" W (211 lbs.)	P6@2.00	Ea	4,240.00	106.00	4,346.00
160,000 Btu, 48" W (211 lbs.)	P6@2.00	Ea	5,190.00	106.00	5,296.00
Deep fat fryer, free standing floor model, electric, 45" height, stainless steel front and top					
40 lbs. capacity (200 lbs.)	P6@2.00	Ea	2,120.00	106.00	2,226.00
60 lbs. capacity (225 lbs.)	P6@2.00	Ea	2,750.00	106.00	2,856.00
Add for filter ready	—	Ea	379.00	—	379.00

11 Equipment

	Craft@Hrs	Unit	Material	Labor	Total
Gas ranges, free standing, floor-mounted, 29-3/4" D x 59" H x 62-3/4" W, with twin ovens and 24" raised griddle/broiler					
6 burners, 35,000 Btu each (835 lbs.)	P6@4.00	Ea	6,180.00	212.00	6,392.00
Add for stainless steel shelf above range	—	Ea	140.00	—	140.00
Restaurant range, gas, 6 burners, 2 ovens, raised griddle/broiler, open burners with black porcelain top grates, stainless steel front, sides, back riser, high shelf and 6" legs. 3/4" rear gas connection with gas pressure regulator. NSF listed.					
50 MBtu/Hr	P6@8.00	Ea	8,660.00	423.00	9,083.00
75 MBtu/Hr	P6@8.00	Ea	10,100.00	423.00	10,523.00
100 MBtu/Hr	P6@8.00	Ea	15,100.00	423.00	15,523.00
Griddles, gas, 27,500 Btu, 1" thick x 24" deep griddle plate, countertop-mounted					
24" wide (295 lbs.)	P6@2.00	Ea	1,300.00	106.00	1,406.00
36" wide (385 lbs.)	P6@2.00	Ea	1,670.00	106.00	1,776.00
48" wide (520 lbs.)	P6@3.00	Ea	2,170.00	159.00	2,329.00
Ovens, free standing, floor-mounted					
Convection oven, natural gas, stainless steel, porcelain interior, 38" W x 36" D x 54-1/4" H					
60,000 Btu (550 lbs.)	D4@4.00	Ea	3,020.00	192.00	3,212.00
Conveyer oven, electric, stainless steel body, 18" H x 50" W x 31-3/8" D, 208 or 240 Volt AC					
16" W conveyer, 6 KW, UL listed (190 lbs.)	D4@4.00	Ea	5,360.00	192.00	5,552.00
Entry & exit shelves	—	Ea	256.00	—	256.00
Professional microwave oven, single shelf, permanent-mount, stainless steel throughout, with 6 minute dial timer, bottom energy feed, see-thru side hinged door, digital controls, cavity- or wall-mount, 120 Volt, 60 Hertz, single phase, Underwriters Laboratories and NSF listed.					
850 watt	E4@4.00	Ea	325.00	205.00	530.00
1,000 watt	E4@4.00	Ea	357.00	205.00	562.00
1,800 watt	E4@4.00	Ea	1,010.00	205.00	1,215.00
2,100 watt	E4@4.00	Ea	1,320.00	205.00	1,525.00
Pastry oven, gas, 6 burners, 2 ovens, raised griddle/broiler, open burners with black porcelain top grates. Stainless steel front, sides, back riser, high shelf and 6" legs. 3/4" rear gas connection with gas pressure regulator. NSF listed.					
50 MBtu/Hr	P6@8.00	Ea	8,270.00	423.00	8,693.00
75 MBtu/Hr	P6@8.00	Ea	10,300.00	423.00	10,723.00
100 MBtu/Hr	P6@8.00	Ea	15,200.00	423.00	15,623.00
Dough roller, production type, for bread, pastry, donut and bagel manufacture. Two-stage machine with stainless steel construction. Quick change handles, front infeed and front discharge. Rolls up to 18" diameter doughs. NSF 8 listed. 120 Volt, 60 Hertz, single phase, UL listed.					
450 pastry blanks per hour	E4@4.00	Ea	5,850.00	205.00	6,055.00
1,000 pastry blanks per hour	E4@4.00	Ea	8,840.00	205.00	9,045.00
2,000 pastry blanks per hour	E4@4.00	Ea	20,500.00	205.00	20,705.00
Bread slicer, hard or soft crusted breads. With stainless steel bagging trough. 3/8" (10 mm), 7/16" (11 mm), 1/2" (13 mm), or 3/4" (19 mm) pre-set slice thickness. Independently mounted heat-treated alloy carbon steel blades. Single phase 115 volt, 60 Hz AC power. ETL listed for safety.					
6.2 Amp/hr, 420 loaves per hour	E4@4.00	Ea	5,850.00	205.00	6,055.00
10 Amp/hr, 700 loaves per hour	E4@4.00	Ea	10,200.00	205.00	10,405.00
18 Amp/hr, 1,000 loaves per hour	E4@4.00	Ea	15,000.00	205.00	15,205.00
Toaster, conveyor type, stainless steel, fused quartz sheathing, countertop model					
350 slices per hour, 115 volt AC, 1,400 watts	D4@3.00	Ea	855.00	144.00	999.00
Pot and pan racks, galvanized steel, pot hooks placed 4 per linear foot					
Ceiling-mounted, 5'	C8@2.00	Ea	546.00	95.20	641.20
Wall-mounted, 5'	C8@2.00	Ea	363.00	95.20	458.20

11 Equipment

	Craft@Hrs	Unit	Material	Labor	Total
Ice-maker, free standing, floor-mounted model					
147 lbs. per day capacity (165 lbs.)	P6@2.00	Ea	1,950.00	106.00	2,056.00
220 lbs. per day capacity (165 lbs.)	P6@2.00	Ea	2,290.00	106.00	2,396.00
290 lbs. per day capacity (215 lbs.)	P6@2.00	Ea	2,690.00	106.00	2,796.00
395 lbs. per day capacity (185 lbs.)	P6@2.00	Ea	3,900.00	106.00	4,006.00
Ice storage unit, self service for bagged ice, 40 cubic foot capacity, floor-mounted. Includes refrigeration unit.					
Indoor type	E4@3.00	Ea	2,780.00	154.00	2,934.00
Outdoor type, automatic defrost	E4@3.00	Ea	2,150.00	154.00	2,304.00
Refrigerators, CFC-free refrigeration system 115 volt AC					
Under counter, stainless steel front and top					
6.2 cubic foot (157 lbs.)	P6@3.00	Ea	1,960.00	159.00	2,119.00
11.8 cubic foot (230 lbs.)	P6@4.00	Ea	3,030.00	212.00	3,242.00
Beverage backbar refrigerator, 2 section glass doors, 34" high, condensing unit on right, galvanized top, stainless steel floors, galvanized interior walls, epoxy coated steel shelves. 208 volt, 1- or 3-phase, 60 Hz AC, Underwriters Laboratories and NSF rated.					
5 MBtu/Hr	E4@4.00	Ea	4,790.00	205.00	4,995.00
10 MBtu/Hr	E4@4.00	Ea	7,530.00	205.00	7,735.00
20 MBtu/Hr	E4@4.00	Ea	10,300.00	205.00	10,505.00
Freezers, under counter type, stainless steel front and top, CFC-free refrigeration system					
6.5 cubic foot (162 lbs.)	P6@.500	Ea	1,890.00	26.50	1,916.50
12.0 cubic foot (234 lb.)	P6@1.00	Ea	2,750.00	52.90	2,802.90
Reach-in refrigerator, bottom-mounted, stainless steel doors, anodized aluminum sides					
Single door, 23 cubic foot (276 lbs.)	P6@4.00	Ea	3,070.00	212.00	3,282.00
Double door, 49 cubic foot (410 lbs.)	P6@4.00	Ea	4,090.00	212.00	4,302.00
Triple door, 72 cubic foot (600 lbs.)	P6@4.00	Ea	5,510.00	212.00	5,722.00
Custom walk-in coolers and freezers, in an existing building. Including thermostatically controlled external remote condenser and temperature recorder. UL and NSF rated compound thermoplastic internal insulation, food-grade grouted tile floor. Fluorescent illumination. High-traffic stainless steel vault door with safety panic bar-style exit latch override. Shelving not included. Per square foot of floor.					
Cooler (to +35 degrees Fahrenheit)	—	SF	—	—	67.80
Freezer (to -35 degrees Fahrenheit)	—	SF	—	—	100.00
Sinks, stainless steel, free standing, floor-mounted, with 7" high backsplash and faucet holes drilled on 8" centers, no trim included					
Scullery sink, 16" x 20" tubs, 12" deep					
40" long, 1 tub, 1 drainboard (65 lbs.)	P6@2.00	Ea	460.00	106.00	566.00
58" long, 2 tubs, 1 drainboard (80 lbs.)	P6@2.00	Ea	698.00	106.00	804.00
103" long, 3 tubs, 2 drainboards (155 lbs.)	P6@2.00	Ea	1,380.00	106.00	1,486.00
126" long, 4 tubs, 2 drainboards (175 lbs.)	P6@2.00	Ea	1,490.00	106.00	1,596.00
Mop sink, faucet not included					
21" x 21" x 41", single compartment	P6@2.00	Ea	423.00	106.00	529.00
Dining facility maintenance and cleaning station, stainless steel throughout. Includes floor-mounted mop sink, hose and cleaning fluid dispenser and connections for mop and bucket fill, shelving and mop racks, shielded lighting fixture, grounded high-mount electrical outlet and floor drain. UL and NSF rated. Built into an existing structure. Add the cost of plumbing and electric rough-in. Per square foot of floor.					
Installed cost	—	SF	—	—	34.50
Planetary food mixing machines, floor-mounted					
20 quart, bench-mount (260 lbs.)	D4@2.00	Ea	2,280.00	96.10	2,376.10
30 quart (360 lbs.)	D4@3.00	Ea	15,600.00	144.00	15,744.00

11 Equipment

	Craft@Hrs	Unit	Material	Labor	Total
Garbage disposers, includes control switch, solenoid valve, siphon breaker and flow control valve					
1/2 HP (56 lbs.)	P6@1.00	Ea	872.00	52.90	924.90
3/4 HP (57 lbs.)	P6@1.00	Ea	1,180.00	52.90	1,232.90
1 HP (60 lbs.)	P6@1.00	Ea	1,240.00	52.90	1,292.90
1-1/2 HP (76 lbs.)	P6@2.00	Ea	1,740.00	106.00	1,846.00
2 HP (81 lbs.)	P6@2.00	Ea	1,840.00	106.00	1,946.00
3 HP (129 lbs.)	P6@3.00	Ea	2,400.00	159.00	2,559.00
Dishwashers					
Under counter, 24 rack capacity per hour. Universal timer					
High temp 70° booster (245 lbs.)	P6@4.00	Ea	5,810.00	212.00	6,022.00
Low temp, chemical sanitizer (245 lbs.)	P6@4.00	Ea	5,040.00	212.00	5,252.00
Upright, heavy duty, semi-automatic, 58 racks per hour. Can be used for corner or straight-through applications					
With booster heater (420 lbs.)	P6@6.00	Ea	13,500.00	317.00	13,817.00
Without booster heater (420 lbs.)	P6@6.00	Ea	11,100.00	317.00	11,417.00
Cappuccino dispenser, for cappuccino, hot chocolate or other hot beverages, 1/4" water line required					
Two flavor, 42 servings	D4@1.00	Ea	1,750.00	48.00	1,798.00
Three flavor, 62 servings	D4@1.00	Ea	1,910.00	48.00	1,958.00
Multi-station decanter coffee brewer, stainless steel, with water feed tank valve connections, permanent countertop-mounted, 115/230 volt single phase 60 Hertz, with warmer plates. UL and NSF rated.					
Single brewer, three warmers	P6@4.00	Ea	822.00	212.00	1,034.00
Single brewer, five warmers	P6@4.00	Ea	932.00	212.00	1,144.00
Twin brewers, eight warmers	P6@8.00	Ea	1,820.00	423.00	2,243.00
Multi-station urn coffee percolator brewer, stainless steel, permanent countertop-mounted, with water feed tank valve connections, 115/230 volt single phase, 60 Hz, with warmer plates. UL and NSF rated.					
Single percolator urn, three warmers	P6@4.00	Ea	761.00	212.00	973.00
Twin percolator urn, five warmers	P6@8.00	Ea	1,010.00	423.00	1,433.00
Beverage dispenser, non-carbonated, refrigerated, countertop model					
5 gallon, 1 bowl	P6@2.00	Ea	939.00	106.00	1,045.00
5 gallon, 2 bowls	P6@2.00	Ea	1,270.00	106.00	1,376.00
2.4 gallon, 2 mini bowls	P6@2.00	Ea	1,130.00	106.00	1,236.00
2.4 gallon, 4 mini bowls	P6@2.00	Ea	1,800.00	106.00	1,906.00
Educational Equipment Labor includes unpacking, layout and complete installation of prefinished furniture and equipment.					
Wardrobes, 40" x 78" x 26"					
Teacher type	C8@2.00	Ea	1,560.00	95.20	1,655.20
Student type	C8@2.00	Ea	786.00	95.20	881.20
Seating, per seat					
Lecture room, pedestal, with folding arm	C8@2.00	Ea	205.00	95.20	300.20
Horizontal sections	C8@2.00	Ea	97.90	95.20	193.10
Tables, fixed pedestal					
48" x 16"	C8@2.00	Ea	445.00	95.20	540.20
With chairs, 48" x 16"	C8@2.00	Ea	636.00	95.20	731.20
Projection screen					
Ceiling-mounted, pull down	D4@.019	SF	4.33	.91	5.24
Videotape recorder	CE@.500	Ea	125.00	30.50	155.50
T.V. camera	CE@.800	Ea	495.00	48.80	543.80
T.V. monitor, wall-mounted	CE@2.00	Ea	289.00	122.00	411.00

11 Equipment

	Craft@Hrs	Unit	Material	Labor	Total
Language laboratory study carrels, plastic laminated wood					
Individual, 48" x 30" x 54"	C8@1.43	Ea	288.00	68.10	356.10
Two position, 73" x 30" x 47"	C8@1.93	Ea	766.00	91.90	857.90
Island, 4 position, 66" x 66" x 47"	C8@3.17	Ea	864.00	151.00	1,015.00

Library equipment, educational and institutional grade. Meets recommendations of the America Library Association. Complies with FEMA 356 standards and ANSI/NISO Z39.73-1994 seismic safety standards. Each 5-level shelf unit is 72" high by 36" wide by 21" deep. Floor-mounted units require four seismic assemblies. Wall-mounted units require two seismic assemblies.

Torch-cut or concrete-saw hole in steel or concrete structural frame for seismic mounts (floor or wall)	D4@1.50	Ea	—	72.00	72.00
Assemble, bolt down and level each seismic spring module	D4@0.25	Ea	163.00	12.00	175.00
Assemble and position bookshelf	D4@1.25	Ea	748.00	60.00	808.00
Bolt down and level completed assembly	D4@0.50	Ea	—	24.00	24.00
Load and vibration test	D4@1.00	Ea	—	48.00	48.00
Computer work station, 29" x 59" x 24", duplex unit, freestanding, Achieva or equal, including assembly and two seismic anchors	C8@1.00	Ea	474.00	47.60	521.60
Computer work center, hexagonal, 26" x 80" x 35", seats six, Paragon or equal, including assembly and three seismic anchors	C8@1.00	Ea	961.00	47.60	1,008.60
Double desk computer work station, 36" W x 30" D, MyOffice or equal, including assembly and two seismic anchors	C8@1.00	Ea	1,530.00	47.60	1,577.60

Rolling Ladders Rolling ladders for mercantile, library or industrial use.

Oak rolling ladder with top and bottom rolling fixtures, non-slip treads, pre-finished. By floor to track height. Painted aluminum hardware. See the cost of ladder track below.

Up to 9'6" high	D4@.819	Ea	1,330.00	39.30	1,369.30
9'6" to 10'6" high	D4@.819	Ea	1,390.00	39.30	1,429.30
10'6" to 11'6" high	D4@1.09	Ea	1,490.00	52.40	1,542.40
11'6" to 12'6" high	D4@1.09	Ea	1,570.00	52.40	1,622.40
12'6" to 13'6" high	D4@1.09	Ea	1,660.00	52.40	1,712.40
13' to 14'6" high	D4@1.09	Ea	1,730.00	52.40	1,782.40
Add for bend at ladder top or bottom	—	Ea	193.00	—	193.00
Add for brass or chrome hardware	—	Ea	219.00	—	219.00
Add for ladder work shelf	—	Ea	150.00	—	150.00
Add for handrail	—	Ea	103.00	—	103.00
Rolling ladder track, 7/8" slotted steel, per foot of length, 9' to 14' high					
Painted aluminum finish	D4@.089	LF	7.94	4.27	12.21
Painted black finish	D4@.089	LF	7.75	4.27	12.02
Brass or chrome plated finish	D4@.089	LF	18.30	4.27	22.57
Corner bend track, 90 degree, 30" radius					
Painted finish	D4@.363	Ea	65.60	17.40	83.00
Chrome or brass finish	D4@.363	Ea	105.00	17.40	122.40

Educational Computer Network Wiring

These estimates assume installation in steel frame interior walls and suspended ceilings before drywall and ceiling finish are installed. All cable runs terminate to either a telephone closet or a server room. All runs are to a punch block at both the distribution end and central interconnect. Underground cable runs assume communications duct has been installed by others. Central interconnect locations are usually a classroom located near or in a cluster of classroom buildings. One-hundred-pair cable is suitable for 12 network connections with 2 spares.

Campus network wiring pulled in underground communications duct from a central interconnection location to a distribution point. Based on a 1,000' cable run.

Category 5E cable					
25 pair cable	E4@.043	LF	1.54	2.21	3.75
100 pair cable	E4@.043	LF	5.58	2.21	7.79

11 Equipment

	Craft@Hrs	Unit	Material	Labor	Total
Cable pulling come-along, 3,000 pound rating					
Rental per day	—	Day	21.00	—	21.00
Rental per week	—	Wk	76.00	—	76.00
Rental per month	—	Mo	229.00	—	229.00
Plywood backboard mount for a wall-mount rack supporting the patch panel and network switches. Set on a masonry wall.					
4' x 4' x 3/4"	E4@.938	Ea	24.40	48.20	72.60
4' x 8' x 3/4"	E4@1.10	Ea	48.90	56.50	105.40
Classroom punch down assembly, wall-mounted, includes frame and 12 port, 110 style punch down. Does not include labor to punch down cable connections.					
Wall mounting frame with 110 style punch down	E4@.250	Ea	141.00	12.80	153.80
Classroom network station wiring, category 5E twisted pair 350 mbps cable pulled in conduit from a classroom to a central interconnect point. Based on 1,000' cable run with conduit installed by others. Add the cost of cable testing below.					
4 pair UTP plenum-rated solid wire cable	E4@.008	LF	0.24	.41	.65
Network cable wall-mount rack with category 6 rack mount patch panels and 110 style punch down blocks. A wall-mount rack will hold eight 6" rack mount devices. Add the cost of cable punch down below.					
24 port patch panel	E4@.250	Ea	409.00	12.80	421.80
48 port patch panel	E4@.350	Ea	594.00	18.00	612.00
96 port patch panel	E4@.450	Ea	906.00	23.10	929.10
Cable punch down. Labor for punch down (connection) on a 110 style block mounted in a classroom, central interconnect point or at server room.					
Per four pair of cable connections	E4@.020	Ea	—	1.03	1.03
Network cable testing, using a dedicated cable tester, shielded or unshielded cable					
Per twisted pair	E4@.125	Ea	—	6.42	6.42
Distribution of patch panel connections to a network switch. Includes 10/100 network switch and patch cables					
24 station connection	CE@.330	Ea	404.00	20.10	424.10
48 station connection	CE@.500	Ea	1,070.00	30.50	1,100.50
96 station connection	CE@1.00	Ea	2,140.00	61.00	2,201.00
Wireless access point. Use the network wire pulling and termination costs above. Access points are commonly installed 12" below the finished ceiling on a small shelf. Add the cost of an electrical outlet at the access point. Count each access point as one station termination and connection.					
Wireless access point	CE@.100	Ea	73.40	6.10	79.50
High gain antenna for extended range on a wireless access point. Add the cost of a RG-6U cable run to the wireless access point.					
18Dbi high gain panel antenna	CE@.100	Ea	132.00	6.10	138.10
Ecclesiastical Equipment Labor includes unpacking, layout and complete installation of prefinished furniture and equipment.					
Lecterns, 16" x 24"					
Plain	C8@4.48	Ea	799.00	213.00	1,012.00
Deluxe	C8@4.48	Ea	1,440.00	213.00	1,653.00
Premium	C8@4.48	Ea	2,800.00	213.00	3,013.00
Pulpits					
Plain	C8@4.77	Ea	903.00	227.00	1,130.00
Deluxe	C8@4.77	Ea	1,400.00	227.00	1,627.00
Premium	C8@4.77	Ea	3,500.00	227.00	3,727.00
Arks, with curtain					
Plain	C8@5.97	Ea	936.00	284.00	1,220.00
Deluxe	C8@5.97	Ea	1,220.00	284.00	1,504.00
Premium	C8@5.97	Ea	2,030.00	284.00	2,314.00

11 Equipment

	Craft@Hrs	Unit	Material	Labor	Total
Arks, with door					
Plain	C8@8.95	Ea	1,060.00	426.00	1,486.00
Deluxe	C8@8.95	Ea	1,790.00	426.00	2,216.00
Premium	C8@8.95	Ea	2,800.00	426.00	3,226.00
Pews, bench type					
Plain	C8@.382	LF	58.70	18.20	76.90
Deluxe	C8@.382	LF	63.90	18.20	82.10
Premium	C8@.382	LF	76.50	18.20	94.70
Pews, seat type					
Plain	C8@.464	LF	73.70	22.10	95.80
Deluxe	C8@.491	LF	96.10	23.40	119.50
Premium	C8@.523	LF	114.00	24.90	138.90
Kneelers					
Plain	C8@.185	LF	14.20	8.81	23.01
Deluxe	C8@.185	LF	18.30	8.81	27.11
Premium	C8@.185	LF	28.90	8.81	37.71
Cathedral chairs, shaped wood					
Without accessories	C8@.235	Ea	191.00	11.20	202.20
With book rack	C8@.235	Ea	207.00	11.20	218.20
With book rack and kneeler	C8@.235	Ea	231.00	11.20	242.20
Cathedral chairs, upholstered					
Without accessories	C8@.285	Ea	199.00	13.60	212.60
With book rack	C8@.285	Ea	215.00	13.60	228.60
With book rack and kneeler	C8@.285	Ea	259.00	13.60	272.60
Adaptable fabric upholstered chair seating (Sauder)					
Hardwood laminated frame, interlocking legs, book rack, stackable, "Modlok"					
Standard	C8@.066	Ea	172.00	3.14	175.14
Deluxe	C8@.066	Ea	188.00	3.14	191.14
Solid oak frame, stackable, "Oaklok"	C8@.066	Ea	141.00	3.14	144.14
Laminated beech frame, stackable, "Plylok"	C8@.066	Ea	155.00	3.14	158.14
Laminated beech frame, stacks & folds, "Plyfold"	C8@.066	Ea	134.00	3.14	137.14
Confessionals, single, with curtain					
Plain	C8@9.11	Ea	3,370.00	434.00	3,804.00
Deluxe	C8@9.11	Ea	4,070.00	434.00	4,504.00
Premium	C8@9.11	Ea	4,640.00	434.00	5,074.00
Add for door in place of curtain	—	Ea	541.00	—	541.00
Confessionals, double, with curtain					
Plain	C8@13.7	Ea	5,360.00	652.00	6,012.00
Deluxe	C8@13.7	Ea	6,200.00	652.00	6,852.00
Premium	C8@13.7	Ea	7,640.00	652.00	8,292.00
Communion rail, hardwood, with standards					
Plain	C8@.315	LF	62.10	15.00	77.10
Deluxe	C8@.315	LF	77.90	15.00	92.90
Premium	C8@.315	LF	93.00	15.00	108.00
Communion rail, carved oak, with standards					
Embellished	C8@.315	LF	101.00	15.00	116.00
Ornate	C8@.315	LF	134.00	15.00	149.00
Premium	C8@.315	LF	223.00	15.00	238.00
Communion rail, bronze or stainless steel, With standards	H6@.285	LF	154.00	15.40	169.40

11 Equipment

	Craft@Hrs	Unit	Material	Labor	Total
Altars, hardwood, sawn					
Plain	C8@5.97	Ea	1,110.00	284.00	1,394.00
Deluxe	C8@5.97	Ea	1,310.00	284.00	1,594.00
Premium	C8@5.97	Ea	1,750.00	284.00	2,034.00
Altars, carved hardwood					
Plain	C8@5.97	Ea	3,280.00	284.00	3,564.00
Deluxe	C8@6.73	Ea	7,600.00	320.00	7,920.00
Premium	C8@7.30	Ea	8,640.00	347.00	8,987.00
Altars, with Nimmerillium fonts, marble	D4@27.8	Ea	5,670.00	1,340.00	7,010.00
Altars, marble or granite					
Plain	D4@29.1	Ea	6,330.00	1,400.00	7,730.00
Deluxe	D4@29.1	Ea	9,190.00	1,400.00	10,590.00
Premium	D4@29.1	Ea	13,700.00	1,400.00	15,100.00
Altars, marble legs and base					
Deluxe	D4@29.1	Ea	3,780.00	1,400.00	5,180.00
Premium	D4@29.1	Ea	5,420.00	1,400.00	6,820.00

Theater & Stage Curtains

Straight track for manual curtains, see lifting and drawing equipment below

Standard duty

24' wide stage	D4@.511	LF	39.40	24.50	63.90
40' wide stage	D4@.330	LF	37.80	15.80	53.60
60' wide stage	D4@.246	LF	36.70	11.80	48.50

Medium duty

24' wide stage	D4@.511	LF	53.80	24.50	78.30
40' wide stage	D4@.330	LF	51.60	15.80	67.40
60' wide stage	D4@.246	LF	50.10	11.80	61.90

Heavy duty

24' wide stage	D4@.511	LF	54.60	24.50	79.10
40' wide stage	D4@.330	LF	52.40	15.80	68.20
60' wide stage	D4@.246	LF	50.80	11.80	62.60

Curved track, manual operation, see lifting and drawing equipment below

Standard duty

24' wide stage	D4@.511	LF	76.20	24.50	100.70
40' wide stage	D4@.392	LF	73.20	18.80	92.00
60' wide stage	D4@.330	LF	71.00	15.80	86.80

Heavy duty

24' wide stage	D4@.644	LF	204.00	30.90	234.90
40' wide stage	D4@.469	LF	196.00	22.50	218.50
60' wide stage	D4@.378	LF	190.00	18.20	208.20

Cyclorama track, manual, see lifting and drawing equipment below

24' wide stage	D4@.511	LF	52.90	24.50	77.40
40' wide stage	D4@.330	LF	50.80	15.80	66.60
60' wide stage	D4@.246	LF	49.30	11.80	61.10

Stage curtains, Subcontract Complete costs for custom fabricated, flameproof stage curtains including labor to hang. No track or curtain lifting or drawing equipment included. By percent of added fullness.

Heavyweight velour

0% fullness	—	SF	—	—	6.92
50% fullness	—	SF	—	—	8.49
75% fullness	—	SF	—	—	8.74
100% fullness	—	SF	—	—	9.43

11 Equipment

	Craft@Hrs	Unit	Material	Labor	Total
Lightweight velour					
0% fullness	—	SF	—	—	5.45
50% fullness	—	SF	—	—	6.13
75% fullness	—	SF	—	—	6.65
100% fullness	—	SF	—	—	8.28
Muslin, 0% fullness	—	SF	—	—	4.09
Repp cloth					
0% fullness	—	SF	—	—	4.40
50% fullness	—	SF	—	—	6.60
75% fullness	—	SF	—	—	6.54
100% fullness	—	SF	—	—	7.23

Stage curtain lifting and drawing equipment Labor is equipment installation, see electrical connection below

Lift curtain equipment					
3/4 HP	D4@8.35	Ea	7,970.00	401.00	8,371.00
1 HP	D4@8.35	Ea	8,200.00	401.00	8,601.00
Draw curtain equipment					
1/3 HP	D4@8.35	Ea	5,980.00	401.00	6,381.00
1/2 HP	D4@8.35	Ea	6,400.00	401.00	6,801.00
3/4 HP	D4@8.35	Ea	6,800.00	401.00	7,201.00

Add for electrical connection. Typical subcontract price for 40' wire run with conduit, circuit breaker, junction box and starter switch.

Per electrical connection	—	Ea	—	—	2,160.00
---------------------------	---	----	---	---	----------

Fresnel-type spotlights and general stage lighting for small to medium (1,500 seat) venues, specialty dimmer rheostats, and breaker panels. Cost includes fixed directional mounting pedestals, prewired electrical conduit, fusing, ground fault protection to *National Electrical Code* standards and main control panel. Equipment cost is a self-propelled electric accordion-style work platform. All electrical components are to Underwriters Laboratories standards.

1,000 watt Fresnel lens light, 6"	E4@5.00	Ea	332.00	257.00	589.00
5,000 watt Fresnel lens light, 10"	E4@5.00	Ea	1,360.00	257.00	1,617.00
Main breaker	E4@1.00	Ea	190.00	51.30	241.30
Dimmer rheostat	E4@1.50	Ea	94.60	77.00	171.60
Spotlight control panel	E4@3.00	Ea	443.00	154.00	597.00
Pre-wired conduit	E4@5.00	CLF	62.90	257.00	319.90
Calibration and test	E4@2.00	Ea	—	103.00	103.00

Stage entertainment sound system Appropriate for a small to medium (1,500 seat) venue. Includes prewired electrical conduit, 8-track digital 80 Gig sound recorder, high-definition 1080i-compliant digital motion picture camera and tripod, 64-channel sound mixing board, sound balancing system, 16-channel linear amplifier, filtered power supply, portable stage monitors, fixed acoustically tuned speaker system, fixed suspended stage microphones, ground fault protection to American Federation of Musicians safety standards and steel security cabinet with heavy-duty lockset for equipment storage. Not included, one day of self-propelled electric accordion-style work platform equipment rental, add as necessary.

Pre-wired conduit	E4@5.00	CLF	54.20	257.00	311.20
Power supply and amplifier	E4@.500	Ea	865.00	25.70	890.70
Fixed speakers	B1@.500	Ea	489.00	17.10	506.10
Ground fault protection	E4@1.00	Ea	325.00	51.30	376.30
Ceiling microphones	E4@1.00	Ea	271.00	51.30	322.30
Digital 1080i-compliant camcorder	—	Ea	6,360.00	—	6,360.00
Mixing and recording table	E4@2.50	Ea	2,710.00	128.00	2,838.00
Security cabinet for mixing and recording table	B1@1.50	Ea	1,310.00	51.20	1,361.20
Calibration and test	E4@4.00	Ea	—	205.00	205.00

11 Equipment

	Craft@Hrs	Unit	Material	Labor	Total
<p>Public address systems For small to medium (1,500 seat) venues such as school assembly halls or civic centers. Includes a linear amplifier, filtered power supply, stage-mounted cable fixtures with covers, pedestal stage microphones, ground fault protection to American Federation of Musicians safety standards, fixed wall-hung speakers, pre-wired permanent conduit runs, removable stage monitors, and security cabinet with lockset for equipment storage.</p>					
Pre-wired conduit	E4@5.00	CLF	55.00	257.00	312.00
Stage cable fixtures	E4@2.00	Ea	11.10	103.00	114.10
Ground fault protection	E4@1.00	Ea	331.00	51.30	382.30
Fixed speakers	B1@.500	Ea	495.00	17.10	512.10
Amplifier and power supply	E4@.500	Ea	881.00	25.70	906.70
Security cabinet	B1@1.50	Ea	1,330.00	51.20	1,381.20
Calibration and test	E4@4.00	Ea	—	205.00	205.00
<p>Acoustically engineered sound reduction paneling Cost includes vertical support studs, spacers, fasteners and trim. Complies with American Institute of Sound Engineering specifications. Per square foot of wall or ceiling covered.</p>					
Sidewall coverage	D2@.040	SF	2.51	1.89	4.40
Ceiling coverage	D2@.060	SF	2.51	2.83	5.34
<p>Specialty mobile HVAC for performing stage zone “spot” cooling to American Federation of Musicians and Screen Actors Guild safety standards. For below-stage mounting in live theaters and for shooting stages for cinema and television work. Includes integral ground fault protection. Material only. Directional ducting costs not included.</p>					
250,000 Btu Unit	—	Ea	—	—	34,800.00
<p>Specialty theater panic exit double doors Includes pre-hung frame, vertical center bar main brace, overhead illuminated light emitting diode “fire exit only” sign, fire alarm system interlocking switch and digital alarm horn, external-only safety lockset and panic bar. To National Fire Protection Association standards and specifications.</p>					
Door frame and vertical bar	B1@8.00	Ea	956.00	273.00	1,229.00
Double doors, per pair	B1@.500	Ea	1,780.00	17.10	1,797.10
Wiring of interlock alarm and sign	E4@2.00	Ea	700.00	103.00	803.00
Calibration and test	E4@3.00	Ea	—	154.00	154.00
<p>Gymnasium and Athletic Equipment</p>					
Basketball backstops					
Fixed, wall-mounted	D4@8.00	Ea	852.00	384.00	1,236.00
Swing-up, wall-mounted	D4@10.0	Ea	1,120.00	480.00	1,600.00
Ceiling suspended, to 20', swing-up manual	D4@16.0	Ea	2,430.00	768.00	3,198.00
Add for glass backstop, fan shape	—	Ea	745.00	—	745.00
Add for glass backstop, rectangular	—	Ea	837.00	—	837.00
Add for power operation	—	Ea	—	—	660.00
Gym floors, typical subcontract prices, not including subfloor or base					
Synthetic gym floor, 3/16"	—	SF	—	—	6.89
Synthetic gym floor, 3/8"	—	SF	—	—	9.07
Built-up wood “spring system” maple floor	—	SF	—	—	12.90
Rubber cushioned maple floor	—	SF	—	—	11.40
Maple floor on sleepers and membrane					
Unfinished	—	SF	—	—	8.90
Apparatus inserts	—	Ea	—	—	47.90
Bleachers, telescoping, manual, per seat	D4@.187	Ea	54.40	8.98	63.38
Bleachers, hydraulic operated, per seat	D4@.235	Ea	72.20	11.30	83.50
Scoreboards, basketball, single face					
Economy	CE@7.01	Ea	1,630.00	428.00	2,058.00
Good	CE@13.0	Ea	2,200.00	793.00	2,993.00
Premium	CE@21.6	Ea	3,490.00	1,320.00	4,810.00

11 Equipment

	Craft@Hrs	Unit	Material	Labor	Total	
Weight room and exercise equipment , commercial and educational facility grade, on a 4" concrete slab supporting special composite low-impact padded exercise room flooring. Costs include labor for bolting of equipment to the floor but do not include the slab or flooring costs, electrical connections where required or cost of equipment assembly.						
Weight machine	B9@.500	Ea	3,160.00	16.70	3,176.70	
Rowing machine	B9@.250	Ea	1,600.00	8.34	1,608.34	
Treadmill	B9@.250	Ea	1,380.00	8.34	1,388.34	
Stationary bicycle	B9@.250	Ea	1,090.00	8.34	1,098.34	
Boxing ring	B9@4.00	Ea	3,000.00	133.00	3,133.00	
Trampoline	B9@4.00	Ea	3,300.00	133.00	3,433.00	
Parallel bars	B9@.500	Ea	2,020.00	16.70	2,036.70	
Balance beam	B9@.250	Ea	1,660.00	8.34	1,668.34	
Playing Fields Typical subcontract costs. Use 3,000 SF as a minimum job charge.						
Playing fields, synthetic surface						
Turf, including base and turf	—	SF	—	—	15.80	
Turf, 3 layer, base foam, turf	—	SF	—	—	17.00	
Uniturf, embossed running surface, 3/8"	—	SF	—	—	11.60	
Running track						
Volcanic cinder, 7"	—	SF	—	—	3.90	
Bituminous and cork, 2"	—	SF	—	—	5.28	
Artificial grass turf , glue-down carpet installation includes cleaning application surface, adhesive, seam seal and rolling. Based on 100 SY job. Challenger Industries, www.challengerturf.com						
Economy grade non-directional turf	F9@.055	SY	6.23	2.57	8.80	
Mid grade non-directional weather resistant turf	F9@.055	SY	7.46	2.57	10.03	
High performance non-directional UV stabilized turf	F9@.055	SY	8.50	2.57	11.07	
Miniature golf style weather resistant turf	F9@.055	SY	8.73	2.57	11.30	
Premium spike-proof non-directional UV stabilized turf	F9@.065	SY	21.50	3.04	24.54	
Padded spike-proof non-directional UV stabilized turf	F9@.065	SY	23.90	3.04	26.94	
Carpet adhesive (25 SY per gallon)	—	Gal	14.20	—	14.20	
Seam sealer (800 LF per gallon)	—	Gal	49.20	—	49.20	
Spike-proof indoor carpeting						
Economy grade patterned carpet	F9@.060	SY	17.10	2.81	19.91	
Mid grade patterned carpet	F9@.060	SY	18.80	2.81	21.61	
Mid grade insignia carpet	F9@.060	SY	25.50	2.81	28.31	
Premium patterned carpet	F9@.060	SY	29.80	2.81	32.61	
	Craft@Hrs	Unit	Material	Labor	Equipment	Total
Athletic Equipment Installed with a 4,000 lb. capacity forklift. Football goals, costs shown are for two goals for one field. Galvanized steel pipe.						
4-1/2" center support post	S6@22.0	Pr	2,960.00	1,030.00	258.00	4,248.00
6-5/8" center support post	S6@24.0	Pr	5,830.00	1,130.00	282.00	7,242.00
Combination football/soccer goal, regulation size, galvanized steel pipe, dual uprights						
	S6@24.0	Pr	2,640.00	1,130.00	282.00	4,052.00
Soccer goals, regulation size, costs shown are for two goals for one field						
Aluminum frame with net	S6@24.0	Pr	3,000.00	1,130.00	282.00	4,412.00
Outdoor, playground style basketball goals, single support, adjustable, 6' backboard extension aluminum fan backboard, hoop and net						
Single goal	S6@12.0	Ea	1,020.00	564.00	141.00	1,725.00
Double goal, back to back	S6@15.0	Ea	1,430.00	706.00	176.00	2,312.00
Volleyball nets, with galvanized posts net, and ground sleeves						
Per net	S6@18.0	Ea	1,100.00	847.00	211.00	2,158.00

11 Equipment

	Craft@Hrs	Unit	Material	Labor	Equipment	Total
Tennis Courts Typical costs for championship size single playing court installation including normal fine grading. These costs do not include site preparation, excavation, drainage, or retaining walls. Equipment, where shown, is a 4,000 lb. capacity forklift. Court is 60' x 120' with asphaltic concrete or Portland cement slab (4" thickness built up to 6" thickness at perimeter). Includes compacted base material and wire mesh reinforcing in concrete.						
Typical cost per court, slab-on-grade	—	LS	—	—	—	28,100.00
Court surface seal coat (7,200 SF)						
One color plus 2" wide boundary lines	—	LS	—	—	—	2,830.00
Fence, 10' high galvanized chain link (360 LF) at court perimeter						
Fencing including gates	—	LS	—	—	—	13,600.00
Lighting						
Typical installation	—	LS	—	—	—	12,700.00
Net posts, with tension reel						
Galvanized steel, 3-1/2" diameter	\$6@6.00	Pr	702.00	282.00	70.50	1,054.50
Galvanized steel, 4-1/2" diameter	\$6@6.00	Pr	776.00	282.00	70.50	1,128.50
Tennis nets						
Nylon	\$6@1.50	Ea	343.00	70.60	17.60	431.20
Polypropylene	\$6@1.50	Ea	500.00	70.60	17.60	588.20
Steel	\$6@1.50	Ea	1,990.00	70.60	17.60	2,078.20
Ball wall, fiberglass, 8' x 12'						
Attached to existing wall	\$6@3.00	Ea	1,900.00	141.00	17.60	2,058.60
Windbreak, 8' high, closed mesh polypropylene						
Lashed to existing chain link fence	\$6@.003	SF	.70	.14	.04	.88

	Craft@Hrs	Unit	Material	Labor	Equipment	Total
Athletic Benches Backed athletic benches, galvanized pipe frame, stationary						
Aluminum seat and back						
7' long	C8@.930	Ea	324.00	44.30		368.30
8' long	C8@1.16	Ea	376.00	55.20		431.20
15' long	C8@1.31	Ea	598.00	62.40		660.40
Fiberglass seat and back						
10' long	C8@.930	Ea	466.00	44.30		510.30
12' long	C8@1.16	Ea	537.00	55.20		592.20
16' long	C8@1.31	Ea	719.00	62.40		781.40
Galvanized steel seat and back						
15' long	C8@1.31	Ea	428.00	62.40		490.40
Backless athletic bench, galvanized pipe frame, stationary, 12" wide x 10' long						
Wood seat	C8@.776	Ea	229.00	36.90		265.90
Steel seat	C8@.776	Ea	249.00	36.90		285.90
Aluminum seat	C8@.776	Ea	288.00	36.90		324.90

Surface Preparation and Striping for Athletic Courts Use \$150 as a minimum job charge.

Surface preparation						
Acid etch concrete surface	PA@.013	SY	.32	.70		1.02
Primer on asphalt	PA@.006	SY	.47	.32		.79
Primer on concrete	PA@.006	SY	.66	.32		.98
Asphalt emulsion filler, 1 coat	PA@.008	SY	.92	.43		1.35
Acrylic filler, 1 coat	PA@.008	SY	1.17	.43		1.60
Rubber/acrylic compound, per coat	PA@.012	SY	2.94	.65		3.59
Acrylic emulsion texture, per coat						
Sand filled	PA@.006	SY	1.95	.32		2.27
Rubber filled	PA@.006	SY	2.03	.32		2.35
Acrylic emulsion color coat, per coat						
Tan, brown, or red	PA@.006	SY	.64	.32		.96
Greens	PA@.006	SY	.74	.32		1.06
Blue	PA@.006	SY	.80	.32		1.12

11 Equipment

	Craft@Hrs	Unit	Material	Labor	Total
Rubber cushioned concrete pavers 18" x 18", dry joints	FL@.039	SF	23.90	2.02	25.92
Striping for athletic courts Marked with white or yellow striping paint					
Lines 3" wide	PA@.005	LF	.08	.27	.35
Lines 4" wide	PA@.005	LF	.11	.27	.38
Lines 4" wide, reflectorized	PA@.002	LF	.26	.11	.37
Lines 8" wide, reflectorized	PA@.004	LF	.54	.22	.76
Marked with reflectorized thermoplastic tape					
Lines 4" wide	PA@.004	LF	1.93	.22	2.15
Lines 6" wide	PA@.006	LF	2.93	.32	3.25
Symbols, lettering Within 2'-0" x 8'-0" template	PA@2.50	Ea	75.50	134.00	209.50

	Craft@Hrs	Unit	Material	Labor	Equipment	Total
Playground Equipment Equipment cost is for a 4,000 lb. capacity forklift. Use \$2,500 as a minimum job charge.						
Balance beams. All are supported 12" above the ground by 2-3/8" OD galvanized pipe uprights.						
10' long "Z"-shaped beam	S6@6.00	Ea	463.00	282.00	70.50	815.50
10' long curved beam	S6@6.00	Ea	601.00	282.00	70.50	953.50
10' long straight beam	S6@6.00	Ea	454.00	282.00	70.50	806.50
15' long straight beam	S6@6.00	Ea	364.00	282.00	70.50	716.50
30' long "Z"-shaped beam	S6@9.00	Ea	710.00	423.00	106.00	1,239.00
Geodesic dome beehive climber, 1" galvanized pipe rungs						
8' diameter, 4' high	S6@24.0	Ea	628.00	1,130.00	282.00	2,040.00
13' diameter, 5' high	S6@36.0	Ea	1,880.00	1,690.00	423.00	3,993.00
18' diameter, 7' high	S6@48.0	Ea	2,350.00	2,260.00	564.00	5,174.00
Horizontal ladders, 20" wide with 1-1/16" OD galvanized pipe rungs 12" OC and 2-3/8" OD galvanized pipe headers and top rails						
12' long, 6' high	S6@6.00	Ea	083.00	282.00	70.50	435.50
18' long, 7' high	S6@9.00	Ea	987.00	423.00	106.00	1,516.00
Rope and pole climbs. Horizontal vertical end posts are 3-1/2" OD galvanized steel tubing.						
10' H x 10' W with three 1-5/8" diameter poles	S6@24.0	Ea	1,180.00	1,130.00	282.00	2,592.00
10' H x 10' W with three 1" diameter ropes	S6@24.0	Ea	1,280.00	1,130.00	282.00	2,692.00
16' H x 12' W with three 1-5/8" diameter poles	S6@24.0	Ea	1,610.00	1,130.00	282.00	3,022.00
16' H x 12' W with three 1-1/2" diameter ropes	S6@24.0	Ea	1,810.00	1,130.00	282.00	3,222.00
Sandboxes, prefabricated. Painted galvanized steel, 12" high, pine seats, sand not included						
6' x 6'	S6@9.00	Ea	501.00	423.00	106.00	1,030.00
12' x 12'	S6@12.0	Ea	711.00	564.00	141.00	1,416.00
Masonry sand	—	CY	46.70	—	—	46.70
Washed plaster sand	—	CY	59.70	—	—	59.70
Concrete sand	—	CY	77.50	—	—	77.50
White silica sand	—	CY	103.00	—	—	103.00
Sand scoopers, crane simulator. Heavy-duty metal construction. Two handles control crane arm height and sand scooper, set in concrete.						
3' high miniature scooper with seat	CL@2.15	Ea	547.00	89.60	75.80	712.40
4' high rotating stand up scooper	CL@2.75	Ea	562.00	115.00	96.90	773.90
Masonry sand	—	CY	46.70	—	—	46.70

11 Equipment

	Craft@Hrs	Unit	Material	Labor	Equipment	Total
Seesaws, galvanized pipe beam with polyethylene saddle or animal seats. Seesaw beam pivots between two coil springs. Double units have seesaw beams spaced 90 degrees apart, set in concrete.						
Single unit, 7' metal base	\$6@5.00	Ea	481.00	235.00	58.70	774.70
Double unit, 4 saddle seats	\$6@9.00	Ea	1,630.00	423.00	106.00	2,159.00
Double unit, 2 animal & 2 saddle seats	\$6@9.00	Ea	2,300.00	423.00	106.00	2,829.00
Double unit, 4 animal seats	\$6@9.00	Ea	2,990.00	423.00	106.00	3,519.00
Spring saws, spring-mounted steel frame with aluminum seats, sets in concrete.						
2' x 12' with two saddle seats	\$6@6.00	Ea	1,120.00	282.00	70.50	1,472.50
12' diameter with two animal seats	\$6@6.00	Ea	756.00	282.00	70.50	1,108.50
12' diameter with four saddle seats	\$6@8.50	Ea	2,280.00	400.00	99.80	2,779.80
12' diameter with four animal seats	\$6@8.50	Ea	969.00	400.00	99.80	1,468.80
12' diameter with six saddle seats	\$6@9.00	Ea	3,360.00	423.00	106.00	3,889.00
12' diameter with six animal seats	\$6@9.00	Ea	1,320.00	423.00	106.00	1,849.00
Slides						
Traditional slide with 18" wide 16 gauge stainless steel slide and galvanized steel stairway.						
Chute 5'H x 10'L Overall length is 13'	\$6@12.0	Ea	1,460.00	564.00	141.00	2,165.00
Chute 6'H x 12'L Overall length is 15'	\$6@12.0	Ea	1,610.00	564.00	141.00	2,315.00
Chute 8'H x 16'L Overall length is 20'	\$6@12.0	Ea	2,150.00	564.00	141.00	2,855.00
Swings, belt seats, galvanized pipe frame						
8' high two-leg ends						
2 seats wood framed	\$6@8.00	Ea	1,650.00	376.00	94.00	2,120.00
2 seats	\$6@12.0	Ea	698.00	564.00	141.00	1,403.00
4 seats	\$6@18.0	Ea	1,190.00	847.00	211.00	2,248.00
6 seats	\$6@24.0	Ea	1,680.00	1,130.00	282.00	3,092.00
10' high two-leg ends						
2 seats	\$6@18.0	Ea	758.00	847.00	211.00	1,816.00
4 seats	\$6@24.0	Ea	1,300.00	1,130.00	282.00	2,712.00
6 seats	\$6@30.0	Ea	1,830.00	1,410.00	352.00	3,592.00
10' high three-leg ends						
4 seats	\$6@24.0	Ea	1,650.00	1,130.00	282.00	3,062.00
6 seats	\$6@30.0	Ea	2,000.00	1,410.00	352.00	3,762.00
8 seats	\$6@36.0	Ea	2,860.00	1,690.00	423.00	4,973.00
12' high three-leg ends						
3 seats	\$6@30.0	Ea	1,360.00	1,410.00	352.00	3,122.00
6 seats	\$6@36.0	Ea	2,050.00	1,690.00	423.00	4,163.00
8 seats	\$6@42.0	Ea	2,830.00	1,980.00	493.00	5,303.00
Add for platform for wheelchair						
Installed on any swing set	\$6@12.0	Ea	789.00	564.00	141.00	1,494.00
Add for seat replacements						
Bucket seat for infant, exchange	—	Ea	48.50	—	—	48.50
Extra bucket seat for infant	—	Ea	112.00	—	—	112.00
Tetherball sets, galvanized pipe post, ground sleeve and chain,						
complete with nylon rope and ball	\$6@3.00	Ea	201.00	141.00	35.20	377.20
Sand for pit (masonry sand)	—	CY	46.70	—	—	46.70

11 Equipment

	Craft@Hrs	Unit	Material	Labor	Equipment	Total
Tower climber. Complete with 8' high fireman's slide pole, "loft" platform, cargo net, horizontal ladders and vertical ladders. Frame is 1-1/4" square steel tubing with painted finish, bracing, ladders and slide pole are 1" OD steel pipe with painted finish. The platform consists of two 30" x 96" fiberglass planks with integral color located 5'0" above the ground. Available in mixed or matched colors.						
8' L x 6' W x 8' H	S6@36.0	Ea	3,830.00	1,690.00	423.00	5,943.00
Arch climbers, 1.9" OD galvanized steel pipe, set in concrete						
2'2" x 10'7"	S6@6.75	Ea	711.00	318.00	32.30	1,061.30
2'2" x 13'11"	S6@7.00	Ea	786.00	329.00	82.00	1,197.00
2'2" x 15'1"	S6@7.00	Ea	905.00	329.00	82.00	1,316.00
15' x 20' four-way climber	S6@10.0	Ea	1,210.00	470.00	118.00	1,798.00
Funnel ball, 3-1/2" OD galvanized steel post with yellow polyethylene hopper						
10' high, set in concrete	S6@4.00	Ea	916.00	188.00	47.00	1,151.00
Chin-up bars, 1-1/2" OD galvanized steel post with 54" and 66" and 84" bar height levels						
12' width, set in concrete	S6@4.75	Ea	531.00	223.00	55.80	809.80
Parallel bars, 1-7/8" OD galvanized steel post, 2'9" high.						
2' x 9'2" set in concrete	S6@6.00	Ea	324.00	282.00	70.50	676.50
Add for motion beam attachment	S6@.250	Ea	221.00	11.80	2.94	235.74

	Craft@Hrs	Unit	Material	Labor	Total
Park Grills Steel grill, set in concrete. Add for cost of concrete.					
Rotating adjustable grill, 40" high with 300 sq. inch cooking area	CM@2.50	Ea	232.00	130.00	362.00
Large grill with two adjustable grates, 40" high with 1,008 sq. inch cooking area	CM@2.75	Ea	461.00	143.00	604.00
Hooded rotating grill, with hood vents, 40" high with 500 sq. inch cooking area	CM@3.00	Ea	580.00	156.00	736.00
Shelterhouse grill with shelves and two grates, 40" high with 1,368 sq. inch cooking area	CM@3.50	Ea	884.00	181.00	1,065.00
Campfire rings with 300 sq. inch cooking area and security brackets set in concrete					
Hinged grate	CM@2.25	Ea	201.00	117.00	318.00
Adjustable grate	CM@2.25	Ea	232.00	117.00	349.00

Medical Refrigeration Equipment Labor costs include unpacking, assembly and installation. Jewett Refrigerator.					
Blood bank refrigerators, upright enameled steel cabinets with locking glass doors, 7 day recording thermometer, LED temperature display, failure alarm, interior lights, and removable drawers. 2 to 4 degree C operating range.					
5 drawer, 240 bag, 16.9 CF, 29" wide x 30" deep x 74" high, #BBR17	D4@2.25	Ea	8,780.00	108.00	8,888.00
6 drawer, 360 bag, 24.8 CF, 29" wide x 36" deep x 83" high, #BBR25	D4@2.25	Ea	9,170.00	108.00	9,278.00
10 drawer, 480 bag, 37.4 CF, 59" wide x 30" deep x 74" high, #BBR37	D4@3.42	Ea	12,700.00	164.00	12,864.00
12 drawer, 720 bag, 55.0 CF, 59" wide x 36" deep x 83" high, #BBR55	D4@3.42	Ea	13,100.00	164.00	13,264.00
Blood plasma storage freezers, upright enameled steel cabinets with locking steel doors, 7 day recording thermometer, LED temperature display, failure alarm, and removable drawers. -30 degree C operating temperature.					
6 drawer, 265 pack, 13.2 CF, 34" wide x 30" deep x 74" high, #BPL13	D4@2.25	Ea	14,900.00	108.00	15,008.00
8 drawer, 560 pack, 24.8 CF, 29" wide x 36" deep x 83" high, #BPL25	D4@2.25	Ea	13,100.00	108.00	13,208.00
16 drawer, 1,120 pack, 55 CF, 59" wide x 36" deep x 83" high, #BPL55	D4@3.42	Ea	20,700.00	164.00	20,864.00

11 Equipment

	Craft@Hrs	Unit	Material	Labor	Total
Laboratory refrigerators, upright enameled steel cabinets with locking steel doors, enameled steel interior, and adjustable stainless steel shelves. 2 to 4 degree C operating temperature.					
4 shelf, 16.9 CF, 29" wide x 30" deep x 74" high #LR17B	D4@2.25	Ea	6,000.00	108.00	6,108.00
8 shelf, 37.4 CF, 59" wide x 30" deep x 74" high #LR37B	D4@3.42	Ea	9,170.00	164.00	9,334.00
Pharmacy refrigerators, upright enameled steel cabinets with locking steel doors, enameled steel interior, and adjustable stainless steel drawers and shelves. -2 degree C operating temperature.					
6 drawer, 1 shelf, 24.8 CF, 29" wide x 36" deep x 83" high, #PR25B	D4@2.25	Ea	6,710.00	108.00	6,818.00
9 drawer, 5 shelf, 55.0 CF, 59" wide x 36" deep x 83" high, #PR55B	D4@3.42	Ea	10,700.00	164.00	10,864.00
Hospital/Lab/Pharmacy undercounter refrigerators, stainless steel interior and exterior, locking door. 24" wide x 24" deep x 34-1/2" high. 2 degree C operating temperature.					
5.4 CF, with blower coil cooling system, stainless steel racks, and auto-defrost, #UC5B	D4@1.67	Ea	3,060.00	80.20	3,140.20
5.4 CF with cold wall cooling system, stainless steel racks, and auto-defrost, #UC5C	D4@1.69	Ea	3,960.00	81.20	4,041.20
Hospital/Lab/Pharmacy undercounter freezers, stainless steel interior and exterior, locking door. 24" wide x 24" deep x 34-1/2" high. -20 degree C operating temperature.					
4.6 CF, stainless steel racks, auto-defrost system, #UCF5B	D4@1.69	Ea	4,350.00	81.20	4,431.20
4.6 CF, stainless steel racks, manual hot gas defrost system, #UCF5C	D4@1.69	Ea	5,130.00	81.20	5,211.20
Morgue refrigerators					
1 or 2 body roll-in type, 39" wide x 96" deep x 76" high, with 1/2 HP, 4,380 Btu/hour condenser, #1SPEC	D4@15.8	Ea	13,900.00	759.00	14,659.00
2 body sliding tray type, 39" wide x 96" deep x 76" high, with 1/2 HP, 4,380 Btu/hour condenser, #2EC	D4@18.0	Ea	13,600.00	865.00	14,465.00
2 body side opening type, 96" wide x 39" deep x 76" high, with 1/2 HP, 4,380 Btu/hour condenser, #2SC	D4@18.0	Ea	15,200.00	865.00	16,065.00
4 or 6 body with roll-in type lower compartments, sliding tray type upper compartments, 73" wide x 96" deep x 102" high, 6,060 Btu/hr, 3/4 HP condenser, #4SPEC2W	D4@22.5	Ea	23,500.00	1,080.00	24,580.00

12 Furnishings

	Craft@Hrs	Unit	Material	Labor	Total
Church Glass Material cost includes fabrication of the lite. Labor cost includes setting in a prepared opening only. Minimum labor cost is usually \$150 per job. Add the cost of scaffold or a hoist, if needed.					
Stained glass					
Simple artwork	G1@.184	SF	78.90	8.99	87.89
Moderate artwork	G1@.318	SF	199.00	15.50	214.50
Elaborate artwork	G1@.633	SF	634.00	30.90	664.90
Faceted glass					
Simple artwork	G1@.184	SF	70.00	8.99	78.99
Moderate artwork	G1@.318	SF	138.00	15.50	153.50
Elaborate artwork	G1@.633	SF	187.00	30.90	217.90
Colored glass, no artwork					
Single pane	G1@.056	SF	7.50	2.74	10.24
Patterned	G1@.184	SF	15.80	8.99	24.79
Small pieces	G1@.257	SF	40.50	12.60	53.10

12 Furnishings

	Craft@Hrs	Unit	Material	Labor	Total
Window Treatment					
Lead mesh fabrics, measure glass size only. Includes allowance for overlap, pleating and all hardware.					
Lead mesh (soundproofing)	—	SY	—	—	29.80
Lead mesh (x-ray) 2.5 lbs per SF	—	SY	—	—	34.10
Draperies, 8' height, fabric quality will cause major variation in prices, per LF of opening, typical installed prices					
Standard quality, window or sliding door	—	LF	—	—	25.80
Better quality, window	—	LF	—	—	85.30
Better quality, sliding door	—	LF	—	—	81.40
Drapery lining	—	LF	—	—	9.71
Fiberglass fabric	—	LF	—	—	82.90
Filter light control type	—	LF	—	—	74.20
Flameproofed	—	LF	—	—	80.60
Velour, grand	—	LF	—	—	107.00

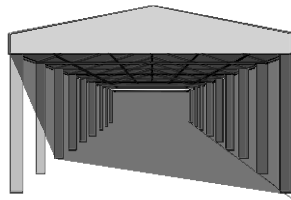

FREESTANDING

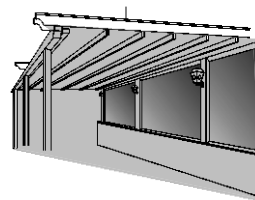

WALL BRACED

Commercial-grade awnings, for restaurant patios, cafés, office outdoor break areas and for solar thermal influx mitigation above glazing. These units meet Western Canvas Products Association standards. Standard fabric is weatherproofed woven, solution-dyed polyester. Complies with Professional Awning Manufacturers Association standards. Arquati Roma, Milano or equal. Add the cost of electric connection and backlighting, if required. Retractable wall-mounted fabric awnings. Lateral arm-type retractable units in lengths to 40 feet and projections to 17 feet. With pitch adjustment arm shoulders, aluminum frame and stainless-steel fasteners.

Reinforcing soffit/wall-mount support and attaching					
transverse-mount support to soffit or wall	H1@2.00	Ea	207.00	110.00	317.00
Lifting and mounting mechanical assembly	H1@2.00	Ea	115.00	110.00	225.00
Mounting and leveling frame, arm and fabric assembly, per SF of fabric					
	H1@.010	SF	27.90	.55	28.45
Adjusting fabric tautness, lateral arm					
tensioning and adjusting arm pulleys	H1@0.50	Ea	—	27.50	27.50
Retractable hood metal-frame lean-to-type awnings. With pre-assembled roller tube and hood assembly, vertical anodized aluminum support hood roller guide columns, curved lintel hood retractor roller guide and transverse wall- or soffit-mounting support plate assembly. Lengths to 42 feet and projections to 22 feet. Includes pitch adjustment arm shoulders, certified aluminum frame construction and stainless-steel fasteners.					
Reinforcing soffit/wall-mount support and attaching					
transverse-mount support to soffit or wall	H1@2.00	Ea	230.00	110.00	340.00
Lifting and mounting mechanical assembly	H1@3.00	Ea	143.00	165.00	308.00
Mounting and leveling frame, vertical supports, reel, drive and fabric assembly, per SF of fabric					
	H1@.010	SF	29.60	.55	30.15
Adjusting fabric tautness, lateral arm					
tensioning and adjusting arm pulleys	H1@0.50	Ea	—	27.50	27.50

12 Furnishings

	Craft@Hrs	Unit	Material	Labor	Total
<p>Freestanding or wall-braced canopy-type awning. With pre-assembled roller tube and hood assembly, vertical anodized aluminum support hood roller guide columns, transverse and parallel anodized aluminum girders with hood expander/retractor roller guide and mounting vertical support base-plate assemblies. Lengths to 42 feet and projections up to 22 feet. Aluminum frame construction, stainless-steel fasteners, motor and controls, rainproof hood, Kevlar pulley cord, roller-bearing pulley and hood guides.</p>					
Reinforcing soffit/wall-mount support and attaching transverse-mount support to soffit or wall	H1@.010	Ea	346.00	.55	346.55
Lifting and mounting mechanical assembly	H1@1.45	Ea	230.00	79.60	309.60
Mounting and leveling frame, arm and fabric assembly, per SF of fabric	H1@.015	SF	35.70	.82	36.52
Adjusting fabric tautness and lateral arm tensioning and adjusting arm pulleys	H1@0.80	Ea	—	43.90	43.90
<p>Additional costs for retractable awnings. Wind sensor, motorized reel, automatic actuator and safety interlock are mandatory for compliance with Dade County (Florida) construction code.</p>					
Add for woven flame-retardant fiber	—	%	5.0	—	—
Add for expanded Teflon-coated glass fiber (PTFE)	—	%	8.0	—	—
Add for painted or laser-printed custom logo and lettering	—	%	3.0	—	—
Add for decal-mounted logo and text	—	%	2.0	—	—
Add for wind sensor, auto crank and safety interlock	—	%	5.0	—	—
Add for motorized crank	—	%	10.0	—	—
Add for calibrating and testing auto crank, wind sensor and automatic actuator	H1@0.80	Ea	—	43.90	43.90
<p>Cabinets Cost per linear foot of the longer of either face or back dimension. Base cabinets are 34" high x 24" deep, wall cabinets are 42" high x 12" deep and full-height cabinets are 94" high x 24" deep. Labor shown is for installing shop-fabricated units. Add for countertops at the end of this section.</p>					
<p>Metal cabinets, shop- and commercial-type, with hardware but no countertop</p>					
Base cabinet, drawer, door and shelf	D4@.379	LF	137.00	18.20	155.20
Wall cabinet with door and 2 shelves	D4@.462	LF	126.00	22.20	148.20
Full-height cabinet, 5 shelves	D4@.595	LF	254.00	28.60	282.60
Library shelving, 48" high x 8" deep modules	D4@.336	LF	89.60	16.10	105.70
Wardrobe units, 72" high x 42" deep	D4@.398	LF	221.00	19.10	240.10
<p>Custom-made wood cabinets, no hardware or countertops included, unfinished, 36" wide modules. For more complete coverage of custom-built cabinets, see <i>National Framing and Finish Carpentry Estimator</i> at https://craftsman-book.com/national-estimator-cloud.</p>					
<p>Standard grade, inexpensive wood veneer or laminate face</p>					
Base	C8@.256	LF	106.00	12.20	118.20
Wall	C8@.380	LF	81.20	18.10	99.30
Full-height	C8@.426	LF	186.00	20.30	206.30
<p>Better grade, wenge wood</p>					
Base, flat slab door panels	C8@.361	LF	204.00	17.20	221.20
Wall, with end panels, edge band, top trim	C8@.529	LF	188.00	25.20	213.20
Island base cabinets, matching back panel	C8@.629	LF	369.00	29.90	398.90
<p>Additional costs for custom wood cabinets</p>					
Prefinished exterior	—	LF	8.99	—	8.99
Prefinished interior	—	LF	15.40	—	15.40
Standard hardware, installed	—	LF	7.18	—	7.18
Institutional grade hardware, installed	—	LF	10.40	—	10.40
Drawer roller guides, per drawer	—	Ea	12.00	—	12.00
Drawer roller guides, suspension, per drawer	—	Ea	37.20	—	37.20

12 Furnishings

	Craft@Hrs	Unit	Material	Labor	Total
Extra drawers					
12" wide	—	Ea	77.30	—	77.30
18" wide	—	Ea	90.60	—	90.60
24" wide	—	Ea	99.00	—	99.00
Classroom-type wood cabinets, laminated plastic face, with hardware but no countertop					
Base cabinet, drawer, door and shelf	C8@.391	LF	248.00	18.60	266.60
Wall cabinet with door and 2 shelves	C8@.475	LF	216.00	22.60	238.60
Full height cabinet with doors	C8@.608	LF	352.00	28.90	380.90
Hospital-type wood cabinets, laminated plastic face, with hardware but no countertop					
Base cabinet, drawer, door and shelf	C8@.982	LF	245.00	46.70	291.70
Wall, with 2 shelves and door	C8@1.15	LF	226.00	54.70	280.70
Full height with doors	C8@1.35	LF	329.00	64.30	393.30
Laboratory-type metal cabinets, with hardware but no countertop					
Base cabinet with door	D4@.785	LF	209.00	37.70	246.70
Base cabinet with drawers	D4@.785	LF	261.00	37.70	298.70
Base cabinets, island base	D4@.785	LF	262.00	37.70	299.70
Wall cabinet with metal door	D4@.785	LF	196.00	37.70	233.70
Wall cabinet with framed glass door	D4@.785	LF	254.00	37.70	291.70
Wall cabinets with no doors	D4@.785	LF	167.00	37.70	204.70
Wardrobe or storage cabinet, 80" high, with door	D4@.939	LF	527.00	45.10	572.10
Storage cabinet, 80" high, no door	D4@.939	LF	317.00	45.10	362.10
Fume hoods, steel, without duct, typical cost	T5@3.88	Ea	1,050.00	200.00	1,250.00
Add for duct, without electric work, typical cost	T5@16.6	LF	1,520.00	854.00	2,374.00

Countertops, shop fabricated, delivered ready for installation.

Laminated plastic tops 2'0" wide over plywood base

Custom work, square edge front, 4" splash	C8@.187	LF	36.10	8.90	45.00
Add for square edge 9" backsplash	—	LF	11.80	—	11.80
Add for solid colors	—	LF	3.48	—	3.48
Add for acid-proof tops	—	LF	26.80	—	26.80
Stainless steel, 2'0" wide with backsplash	C8@.366	LF	94.30	17.40	111.70

Cigarette Disposal Units

20 gauge stainless steel with grate. For cigarettes and cigars

5-1/4" x 5-3/16" x 8-3/8" wall mounted	CM@.500	Ea	184.00	25.90	209.90
5-1/4" x 5-3/16" x 8-3/8" pole mounted	CM@.750	Ea	195.00	38.90	233.90
13" x 16" x 43" wall mounted	CM@.600	Ea	224.00	31.10	255.10
13" x 16" x 43" pole mounted	CM@.900	Ea	252.00	46.70	298.70
15" x 16" x 43" wall mounted with trash can	CM@.750	Ea	527.00	38.90	565.90
15" x 16" x 43" pole mounted with trash can	CM@1.25	Ea	551.00	64.80	615.80

Recessed Open Link Entry Mats These costs assume that mats are mounted in an aluminum frame recessed into a concrete walkway and do not include concrete work, special designs or lettering

Polypropylene, 3/8" thick	D4@.560	SF	7.69	26.90	34.59
Coconut husk fiber, 1/2" thick	D4@.560	SF	7.60	26.90	34.50
Recessed vinyl link	D4@.560	SF	22.00	26.90	48.90

12 Furnishings

	Craft@Hrs	Unit	Material	Labor	Total
Entrance Mats and Recessed Foot Grilles These costs assume installation of an extruded aluminum tread foot grille on a level surface or over a catch basin with or without a drain.					
Pedigrid/Pedimat extruded aluminum entrance mat					
Grid mat with carpet treads	D4@.150	SF	38.20	7.20	45.40
Grid mat with vinyl treads	D4@.150	SF	41.50	7.20	48.70
Grid mat with pool or shower vinyl treads	D4@.150	SF	46.00	7.20	53.20
Grid mat with abrasive serrated aluminum treads	D4@.150	SF	46.40	7.20	53.60
Recessed catch basin with 2" drain	D4@.302	SF	51.30	14.50	65.80
Recessed catch basin without drain	D4@.242	SF	48.30	11.60	59.90
Level base recessed mount	D4@.150	SF	46.10	7.20	53.30
Surface-mount frame, vinyl	—	LF	4.61	—	4.61
Recessed-mount frame, bronze aluminum	D4@.092	LF	10.50	4.42	14.92
Seating These costs do not include concrete work					
Theater style, economy	D4@.424	Ea	156.00	20.40	176.40
Theater style, lodge, rocking type	D4@.470	Ea	308.00	22.60	330.60
Bleachers, closed riser, extruded aluminum, cost per 18" wide seat					
Portable bleachers	D4@.090	Ea	67.60	4.32	71.92
Portable bleachers with guardrails	D4@.136	Ea	75.20	6.53	81.73
Team bleachers, stationary	D4@.090	Ea	58.00	4.32	62.32
Stadium seating, on concrete foundation by others, extruded aluminum, cost per 18" seat width					
10" flat bench seating, seatboard only	D4@.090	Ea	19.70	4.32	24.02
12" contour bench seating, seatboard only	D4@.090	Ea	20.80	4.32	25.12
Chair seating, molded plastic	D4@.310	Ea	112.00	14.90	126.90
Replacement bench seating, stadium or bleacher, extruded aluminum					
Cost per 18" seat width					
10" wide flat seatboard only	D4@.069	Ea	12.30	3.31	15.61
10" wide flat seatboard and footboard	D4@.136	Ea	26.60	6.53	33.13
12" contour seatboard only	D4@.069	Ea	14.60	3.31	17.91
Benches					
Floor-mounted wood locker room bench, metal pedestal bolted to a concrete floor.					
Hardwood top, 6' long, 12" wide	D4@.753	Ea	232.00	36.20	268.20
Park bench, for public and commercial use. Cast aluminum with treated 1-1/2" by 2-1/4" pine wood slats. Central Park or Victorian style.					
4' long	D4@.750	Ea	268.00	36.00	304.00
5' long	D4@.750	Ea	291.00	36.00	327.00
6' long	D4@.750	Ea	330.00	36.00	366.00
Bicycle, Moped and Motorcycle Security Racks Installation kit includes tamper proof bolts and quick setting cement. Locks supplied by users. Labor is to install units on concrete surface. Cost per bicycle or motorcycle of capacity. Add cost for drilling holes in concrete as needed. These costs are based on a minimum purchase of six racks.					
Basic bicycle rack					
5' long, looped steel, holds 8 bikes	C8@1.00	Ea	292.00	47.60	339.60
7' long, looped steel, holds 12 bikes	C8@1.25	Ea	358.00	59.50	417.50
10' long, single sided, holds 9 bikes	C8@.862	Ea	313.00	41.00	354.00
20' long, single sided, holds 18 bikes	C8@1.50	Ea	561.00	71.40	632.40
10' long, double sided, holds 18 bikes	C8@1.50	Ea	404.00	71.40	475.40
20' long, double sided, holds 36 bikes	C8@1.00	Ea	711.00	47.60	758.60

12 Furnishings

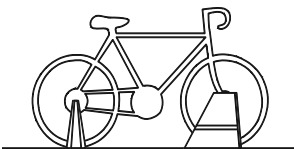
	Craft@Hrs	Unit	Material	Labor	Total
Moped or motorcycle rack					
With 24" security chain	C8@.575	Ea	146.00	27.40	173.40
Add for mounting track for use on asphalt or non-concrete surfaces. No foundation work included. Each 10' track section holds 6 bicycle racks or 4 moped or motorcycle racks.					
Per 10' track section, including drilling holes	C8@2.50	Ea	151.00	119.00	270.00
Add for purchasing less than six mounting racks	—	Ea	17.70	—	17.70
Add for drilling mounting holes in concrete, 2 required per rack, cost per rack	C8@.125	Ea	—	5.95	5.95
Bicycle racks, galvanized pipe rack, embedded or surface mounted to concrete, cost per rack					
Double entry					
5' long, 7 bikes	C8@3.31	Ea	329.00	158.00	487.00
10' long, 14 bikes	C8@3.31	Ea	473.00	158.00	631.00
20' long, 28 bikes	C8@4.88	Ea	861.00	232.00	1,093.00
30' long, 42 bikes	C8@6.46	Ea	1,250.00	307.00	1,557.00
Single side entry					
5' long, 4 bikes	C8@2.41	Ea	313.00	115.00	428.00
10' long, 8 bikes	C8@2.41	Ea	355.00	115.00	470.00
20' long, 16 bikes	C8@3.55	Ea	642.00	169.00	811.00
					
Wood and metal rack, embedded or surface mounted					
Double entry					
10' long, 14 bikes	C8@3.31	Ea	516.00	158.00	674.00
20' long, 28 bikes	C8@4.88	Ea	964.00	232.00	1,196.00
Single entry					
10' long, 8 bikes	C8@2.41	Ea	430.00	115.00	545.00
20' long, 10 bikes	C8@3.55	Ea	772.00	169.00	941.00
Bike post bollard,					
dimensional wood, concrete footing	C8@.223	Ea	235.00	10.60	245.60
Single tube galvanized steel, looped wave pattern, 30" high, surface mounted					
3' long, 5 bikes	C8@3.45	Ea	766.00	164.00	930.00
5' long, 7 bikes	C8@3.45	Ea	878.00	164.00	1,042.00
7' long, 9 bikes	C8@4.61	Ea	1,130.00	219.00	1,349.00
9' long, 11 bikes	C8@4.61	Ea	1,340.00	219.00	1,559.00
Bonded color, add	—	Ea	116.00	—	116.00
Add for embedded mounting	C8@1.77	Ea	29.20	84.30	113.50

13 Special Construction

	Craft@Hrs	Unit	Material	Labor	Total
Swimming Pools Complete in-ground pool including typical excavation, reinforcing, gunite, filter, pump, pop-up cleaning heads and circulation manifold, skimmer, PVC supply and backwash piping, float valve, ladder, electrical controls and one pool light. Add the cost of deck beyond the edge of coping, electrical supply, a pool equipment slab and enclosure, if required. Typical subcontract prices per SF of water surface.					
Apartment building	—	SF	—	—	77.30
Community	—	SF	—	—	99.60
Hotel or resort	—	SF	—	—	93.60
School, training (42' x 75')	—	SF	—	—	105.00
School, Olympic (42' x 165')	—	SF	—	—	158.00

13 Special Construction

	Craft@Hrs	Unit	Material	Labor	Total
Swimming pool covers, retractable motor-operated, track mounted, including the motor, gearing, retracting reel, pulley system, electric controls and remote switch. For square or rectangular pools. Add the cost of concrete work for the winding reel enclosure, electric supply and the cover.					
3/4 HP drive motor and reel (to 600 SF water surface)	—	Ea	—	—	5,200.00
1-1/4 HP drive motor and reel (to 1,200 SF water surface)	—	Ea	—	—	6,500.00
Add for the vinyl cover, per SF of water surface	—	SF	—	—	4.67

	Craft@Hrs	Unit	Material	Labor	Equipment	Total
--	-----------	------	----------	-------	-----------	-------

Access for the Disabled

Use the following cost estimates when altering an existing building to meet requirements of the Americans with Disabilities Act (ADA). The ADA requires that existing public and private buildings be altered to accommodate the physically handicapped when that can be done without unreasonable difficulty or expense.

Ramps, flared aprons and landings Concrete access ramps, flared aprons and landings, 2,000 PSI concrete placed directly from the chute of a ready-mix truck, vibrated and finished. Costs include typical wire mesh reinforcing and an allowance for waste but no excavation, backfill or foundations.

Access ramps, based on ramps with 1" rise per 1' of run, 4" thick walls and 4" thick slab. Includes pipe sleeves for railings, sand fill in cavity and non-slip surface finish						
24" vertical rise (4' wide x 25' long)	C8@40.0	Ea	1,760.00	1,900.00	—	3,660.00
36" vertical rise (4' wide x 38' long)	C8@60.0	Ea	3,370.00	2,860.00	—	6,230.00
48" vertical rise (4' wide x 50' long)	C8@96.0	Ea	4,930.00	4,570.00	—	9,500.00

Access aprons at curbs, flared and inclined, 2' long x 8' wide						
4" thick (80 SF per CY)	P9@.024	SF	4.28	1.18	—	5.46
6" thick (54 SF per CY)	P9@.032	SF	6.46	1.57	—	8.03

Landings, 4" thick walls on three sides and 4" thick top slab cast against an existing structure on one side. Costs include pipe sleeves for railings, sand fill in cavity and an allowance for waste.						
3'0" high with 6' x 6' square slab	C8@32.0	Ea	1,450.00	1,520.00	—	2,970.00
Add per vertical foot of height over 3'0"	—	VLF	275.00	—	—	275.00

Steel access ramps, 4140 carbon steel, 1" rise per foot of run, 8 gauge diamond pattern steel plate and 2" diameter handrail with electrostatic vinyl paint coating. Includes fabrication and assembly but no excavation. Add the cost of post foundations.						
Per square foot of ramp surface	T3@.150	SF	5.52	8.06	—	13.58

Redwood access ramps, S4S kiln-dried or better redwood, based on ramps with 1-inch rise per foot of run, 6" x 6" posts supporting 2" x 12" beams with steel cross-bracing 36" OC. 2" x 6" decking with 2" diameter railing. Includes fabrication and assembly but no excavation. Add the cost of post foundations.						
Per square foot of ramp surface	B9@.150	SF	3.85	5.00	—	8.85

Snow-melting cable for ramps and landings. Includes 208-277 volt AC self-regulating heater cable designed to be encased in concrete. Based on cable connected to an existing power source adjacent to the installation						
Heater cable						
(1.1 LF per SF of pavement)	CE@.015	SF	12.20	.92	—	13.12
Power connection kit	CE@.500	Ea	35.70	30.50	—	66.20
Thermostat	CE@.500	Ea	241.00	30.50	—	271.50

Railing for ramps and landings Welded steel. Equipment cost shown is for a flatbed truck and a welding machine.						
Wall-mounted handrails with brackets 5' OC, based on 12' lengths						
1-1/4" diameter rail, shop prime painted	H6@.092	LF	10.30	4.98	.50	15.78
1-1/2" diameter rail, shop prime painted	H6@.102	LF	12.00	5.52	.55	18.07
Add for galvanized finish	—	%	20.0	—	—	—

13 Special Construction

	Craft@Hrs	Unit	Material	Labor	Equipment	Total
Floor-mounted railings 3'6" high with posts 5' OC, based on 12' length						
1-1/4" diameter rails and posts, shop prime painted						
2-rail type	H6@.115	LF	42.40	6.23	.62	49.25
3-rail type	H6@.125	LF	55.00	6.77	.68	62.45
1-1/2" diameter rails and posts, shop prime painted						
2-rail type	H6@.125	LF	51.10	6.77	.68	58.55
3-rail type	H6@.137	LF	67.30	7.42	.74	75.46
Add for galvanized finish	—	%	20.0	—	—	—
Drinking fountains and water coolers for the disabled						
Remove an existing drinking fountain or water cooler and disconnect waste and water piping at the wall adjacent to the fixture for use with the new fixture. No salvage value assumed.						
Floor or wall-mounted fixture	P6@1.00	Ea	—	52.90	—	52.90
Install a wall-hung white vitreous china fountain with chrome plated spout, 14" wide, 13" high, non-electric, self-closing dispensing valve and automatic volume control						
Drinking fountain, trim and valves	P6@2.80	Ea	927.00	148.00	—	1,075.00
Wheelchair wall-hung water cooler, vitreous china, refrigerated, (no electrical work included)						
Wall-hung water cooler and trim (add rough-in)	P6@2.50	Ea	1,070.00	132.00	—	1,202.00
Install floor or wall-mounted electric water cooler, 8 gallons per hour, cold water only, connected to existing electrical outlet adjacent to the cooler (no electrical work included)						
Water cooler, trim and valves	P6@2.80	Ea	1,870.00	148.00	—	2,018.00
Parking stall marking for the disabled						
Remove existing pavement marking by water blasting						
4" wide stripes (allow 40 LF per stall)	CL@.032	LF	—	1.33	.47	1.80
Markings, per square foot (minimum 10 SF)	CL@.098	SF	—	4.08	1.43	5.51
Mark parking stall with handicapped symbol painted on, including layout						
Reflectorized stripes and symbol, one color. Add \$75 per day for rental of a compressor, hose and spray gun.						
Per stall, no striping	PA@.425	Ea	16.20	22.90	—	39.10
Parking lot handicapped sign, 12" x 18" laminated aluminum, reflective lettering and handicapped symbol						
Sign on 2" galvanized steel pipe post 10' long, set 2' into the ground. Includes digging of hole						
Using a manual auger and backfill	CL@1.25	Ea	108.00	52.10	—	160.10
On walls with mechanical fasteners	PA@.455	Ea	35.70	24.50	—	60.20
Paving and curb removal These costs include breaking out the paving or curb for ADA improvements, loading and hauling debris to a legal dump within 6 miles but no dump fees. Equipment cost per hour is for one 90 CFM air compressor, one paving breaker with jackhammer bits, one 55 HP wheel loader with integral backhoe and one 5 CY dump truck. The figures in parentheses show the approximate "loose" volume of the materials (volume after being demolished). Use \$250 as a minimum charge for this type work and add dump charges as a separate item.						
Asphalt paving, depths to 3" (27 SF per CY)						
	C3@.040	SF	—	1.95	1.32	3.27
Asphalt curbs, to 12" width (18 LF per CY)						
	C3@.028	LF	—	1.36	.92	2.28
Concrete paving and slabs on grade						
4" concrete without rebar (54 SF per CY)						
	C3@.060	SF	—	2.92	1.98	4.90
6" concrete without rebar (45 SF per CY)						
	C3@.110	SF	—	5.36	3.63	8.99
Add for removal of bar reinforced paving	C3@.200	SF	—	9.74	6.60	16.34

13 Special Construction

	Craft@Hrs	Unit	Material	Labor	Equipment	Total
Curb, gutter and paving for the disabled These costs assume 3 uses of forms and 2,000 PSI concrete placed directly from the chute of a ready-mix truck. Use \$250 as a minimum charge for this type work.						
Concrete cast-in-place vertical curb, including 2% waste, forms and finishing. These costs include typical excavation and backfill with excess excavation spread on site.						
6" x 12" straight curb	P9@.136	LF	6.69	6.67	—	13.36
6" x 18" straight curb	P9@.149	LF	9.93	7.30	—	17.23
6" x 24" straight curb	P9@.154	LF	13.20	7.55	—	20.75
Add for curved sections	—	%	—	40.0	—	—
Curb and 24" monolithic gutter (7 LF per CY)	C3@.100	LF	14.00	4.87	—	18.87
Concrete paving and walkway, 4" thick	P8@.025	SF	3.19	1.17	—	4.36
Add for integral colors, most pastels	—	SF	.45	—	—	.45

Plumbing fixtures for the disabled

Remove existing plumbing fixtures. Disconnect from existing waste and water piping at the wall adjacent to the fixture. Waste and water piping to remain in place for connection to a new fixture. No salvage value assumed.

Lavatories	P6@1.00	Ea	—	52.90	—	52.90
Urinals	P6@1.00	Ea	—	52.90	—	52.90
Water closets, floor or wall mounted	P6@1.00	Ea	—	52.90	—	52.90
Install new fixtures. White vitreous china fixtures with typical fittings, hangers, trim and valves. Connected to waste and supply piping from lines adjacent to the fixture.						
Lavatories, wall hung	P6@1.86	Ea	747.00	98.40	—	845.40
Water closets, tank type, with elongated bowl, toilet seat, trim and valves						
Floor mounted, with bowl ring	P6@1.86	Ea	404.00	98.40	—	502.40
Wall hung, with carrier	P6@2.80	Ea	853.00	148.00	—	1,001.00

Plumbing partitions and grab bars for the disabled

Remove a standard toilet partition, no salvage value included. Floor or ceiling mounted

Remove one wall and one door	T5@1.00	Ea	—	51.50	—	51.50
Install toilet partition designed for wheelchair access. Floor or ceiling mounted. These costs include one wall and one door, mechanical fasteners and drilling of holes						
Powder coated metal	T5@2.66	Ea	682.00	137.00	—	819.00
Solid plastic (polymer)	T5@4.00	Ea	1,100.00	206.00	—	1,306.00
Laminated plastic	T5@2.66	Ea	678.00	137.00	—	815.00
Stainless steel	T5@2.66	Ea	1,330.00	137.00	—	1,467.00
Grab bars, stainless steel, wall mounted, commercial grade. Set of two required for each stall. Including mechanical fasteners and drilling of holes						
1-1/4" x 24" urinal bars	CC@1.00	Set	128.00	53.50	—	181.50
1-1/4" x 36" toilet partition bars	CC@1.00	Set	157.00	53.50	—	210.50

	Craft@Hrs	Unit	Material	Labor	Total
--	-----------	------	----------	-------	-------

Signage in Braille Standard signs (Rest Room, Elevator, Telephone, Stairway, etc.) mounted with self-stick foam, velcro or in frame. Add the cost of frames, if required, from below.

5/8" lettering raised 1/32". Grade 2 Braille raised 1/32"						
2" x 8" sign, raised letters and tactile Braille	PA@0.25	Ea	44.70	13.40	—	58.10
8" x 8" sign with words, graphic symbols and tactile Braille	PA@0.25	Ea	77.40	13.40	—	90.80
standard graphic symbols	PA@0.25	Ea	77.40	13.40	—	90.80
Sign frames. Signs snap into frames mounted with mechanical fasteners						
2" x 8" frames, black, almond or grey	PA@0.25	Ea	36.80	13.40	—	50.20
8" x 8" frames, black, almond or grey	PA@0.25	Ea	68.60	13.40	—	82.00

13 Special Construction

	Craft@Hrs	Unit	Material	Labor	Total
Elevator plates. Sign with graphic symbols and tactile Braille, standard colors					
Door jamb plates, 7" x 11", two per opening	PA@0.75	Set	93.70	40.30	134.00
Operation plates, Open Door, Close Door, Emergency Stop, Alarm,					
1-1/4" x 1-1/4", set of four required per car	PA@1.00	Set	82.90	53.80	136.70
Operation plates, Floor Number, 1-1/4" x 1-1/4"					
One required for each floor per car	PA@0.25	Ea	20.40	13.40	33.80
Handicapped automatic remote door opener , 60 Hz, single phase, 110 volts, with manual override, electro-pneumatic actuator arm assembly, manual panic bar, door open-position locks, prehung twin metal doors, digital operation cycle setting module, actuator button panel, power/service panel. Americans With Disabilities Act compliant.					
Twin door frame	C8@4.00	Ea	345.00	190.00	535.00
Twin doors, per pair	C8@.250	Ea	2,670.00	11.90	2,681.90
Actuator arms for twin doors	C8@0.50	Ea	408.00	23.80	431.80
Automatic remote door controls	C8@4.00	Ea	245.00	190.00	435.00
Actuator mechanism	—	Ea	3,030.00	—	3,030.00
Bus stop shelters Prefabricated structure systems, shipped knocked-down. Complete with all hardware and foundation anchors. Labor cost is for assembly on site. Add the cost of foundation and floor slab. Dimensions are approximate outside measurements. Based on Columbia Equipment Company.					
Three-sided open front type. Clear satin silver anodized aluminum structure and fascia, 1/4" clear acrylic sheet glazing in panels and white baked enamel finish aluminum "V"-beam roof.					
9'2" L x 5'3" W x 7'5" H					
Two rear panels, single panel each side	C8@8.00	Ea	5,210.00	381.00	5,591.00
Four rear panels, two panels each side	C8@12.0	Ea	5,470.00	571.00	6,041.00
11'3" L x 5'3" W x 7'5" H					
Four rear panels, two panels each side	C8@12.0	Ea	6,390.00	571.00	6,961.00
Add to three-sided open front shelters for the following:					
Wind break front entrance panel					
5'3" W x 7'5" H, with two glazed panels	C8@2.00	Ea	631.00	95.20	726.20
Bus stop enclosures, aluminum frame with Plexiglas sidewall elements, 12' wide by 30' long by 10' high, barrel roof with diamond pattern grille work, aluminum bench, solar lighting and bronze anodized finish.					
Shelter assembly, bolted to the foundation	B5@8.00	Ea	22,100.00	299.00	22,399.00
Structure leveling	B5@2.00	Ea	100.00	74.70	174.70
Bus stop bench, all aluminum vandal-resistant seat and backrest					
8'0" long	C8@1.00	Ea	575.00	47.60	622.60
10'0" long	C8@1.50	Ea	747.00	71.40	818.40
Light fixture with unbreakable Lexan diffuser, wiring not included					
100 watt incandescent, photoelectric cell control	C8@2.00	Ea	284.00	95.20	379.20
Radiant heater, with vandal-resistant electric heating element in heavy duty enclosure and metal mesh guard over opening. Wiring not included.					
2,500 watt unit (no controls)	C8@1.50	Ea	1,60.00	71.40	231.40
5,000 watt unit (no controls)	C8@1.50	Ea	1,240.00	71.40	1,311.40
Add for electronic timer control	C8@1.00	Ea	558.00	47.60	605.60

13 Special Construction

	Craft@Hrs	Unit	Material	Labor	Total
Integrated map/schedule display panel, anodized aluminum frame, tamper-proof fasteners and "spanner-head" tool for opening.					
Full panel width x 30" high					
3/16" clear Plexiglas	C8@1.00	Ea	199.00	47.60	246.60
3/16" polycarbonate with mar-resistant coating	C8@1.00	Ea	308.00	47.60	355.60
Graphics, words "Bus Stop" in white letters, on fascia					
First side	—	LS	116.00	—	116.00
Each additional side	—	Ea	40.40	—	40.40

Metal shelter structures Prefabricated structure systems, shipped knocked-down, complete with all necessary hardware. Labor cost is for assembly on site. Typical use is for picnic pavilions. These costs do not include foundation or floor slab. Dimensions are approximate outside measurements. Based on Americana Building Products. www.americana.com

Four-sided hip roof shelter. Steel structural rafters and columns, aluminum roof decking with stucco embossed, painted finish, 8' height at perimeter.

12' L x 12' W	S4@32.0	Ea	7,400.00	1,330.00	8,730.00
16' L x 16' W	S4@32.0	Ea	9,100.00	1,330.00	10,430.00
16' L x 32' W	S4@36.0	Ea	12,300.00	1,500.00	13,800.00
20' L x 20' W	S4@36.0	Ea	11,400.00	1,500.00	12,900.00
20' L x 30' W	S4@36.0	Ea	14,700.00	1,500.00	16,200.00
20' L x 40' W	S4@36.0	Ea	18,000.00	1,500.00	19,500.00
24' L x 24' W	S4@36.0	Ea	14,700.00	1,500.00	16,200.00
24' L x 48' W	S4@40.0	Ea	21,200.00	1,670.00	22,870.00
Add for 48" x 48" cupola with tubular metal frame	S4@1.50	Ea	1,490.00	62.50	1,552.50
Add for 6' x 12' cupola with tubular metal frame	S4@3.50	Ea	6,120.00	146.00	6,266.00

Gable roof shelter. Steel structural rafters and columns, aluminum roof and trim. 8' height, 3 in 12 roof pitch.

20' L x 20' W	S4@36.0	Ea	6,750.00	1,500.00	8,250.00
20' L x 24' W	S4@36.0	Ea	9,750.00	1,500.00	11,250.00
20' L x 30' W	S4@36.0	Ea	10,400.00	1,500.00	11,900.00
20' L x 50' W	S4@40.0	Ea	17,600.00	1,670.00	19,270.00
22' L x 20' W	S4@36.0	Ea	7,180.00	1,500.00	8,680.00
22' L x 30' W	S4@36.0	Ea	11,100.00	1,500.00	12,600.00
22' L x 40' W	S4@36.0	Ea	14,700.00	1,500.00	16,200.00
22' L x 50' W	S4@40.0	Ea	18,200.00	1,670.00	19,870.00

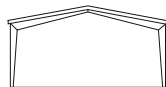

Modular Buildings (Manufactured housing)

Relocatable structures and institutional type housing for remote areas. Costs are per square foot under the roof. Based on 2" x 4" wood studs 16" OC, 1/2" gypsum wallboard inside and 1/2" CDX plywood outside, with minimum plumbing, heating, cooling and electrical systems for the intended use. Costs include factory assembly, delivery by truck to within 50 miles, setting on piers, on-site finishing ("button up"), skirting, steps and rails. Add the cost of utility hookups, permits, taxes and fees. Add 1.5% for each additional 50 miles of delivery. No site preparation or furnishings included. Cost for smaller, more complex structures will be higher. For more detailed coverage of manufactured housing costs, see Craftsman's National Appraisal Estimator at <https://craftsman-book.com/national-appraisal-estimator-online-software>.

Portable structures (temporary offices, school classrooms, etc.)

Medium quality	—	SF	—	—	77.60
Better quality	—	SF	—	—	95.90
Institutional housing, four-plex modules					
Medium quality	—	SF	—	—	100.00
Better quality	—	SF	—	—	101.00
Construction or mining camp barracks, mess halls, kitchens, etc.					
Single story structures	—	SF	—	—	88.00

13 Special Construction

Craft@Hrs Unit Material Labor Total

Air-Supported Structures Air-supported pool or tennis court enclosures, dual-layer polyester reinforced vinyl dome, with zippered entry air lock doors, cable tiedowns and air blower. Typical cost per square foot of area covered including foundation and indirect lighting. Add the cost of grading, drainage and electric service.

Under 12,000 SF	D4@.030	SF	16.80	1.44	18.24
12,000 to 24,000 SF	D4@.030	SF	15.40	1.44	16.84
24,000 to 30,000 SF	D4@.030	SF	14.10	1.44	15.54
30,000 to 36,000 SF	D4@.030	SF	13.50	1.44	14.94
36,000 to 45,000 SF	D4@.030	SF	13.20	1.44	14.64
45,000 to 80,000 SF	D4@.030	SF	13.10	1.44	14.54
80,000 to 110,000 SF	D4@.030	SF	13.00	1.44	14.44
Add for standby blower motor	—	%	—	—	10.0
Add for revolving door	—	Ea	—	—	5,700.00
Add for emergency exit	—	Ea	—	—	1,930.00

Sunrooms, solariums and conservatories. Custom-designed three-wall building additions supplied in kit form for assembly on site. Aluminum frame mounted on an existing 6" concrete slab with 12" wide x 18" deep footing. Moving glass panels have two adjustable tandem nylon wheel assemblies. Size is limited to 20'-wide roof span, 100' length and 18' height. Meets Architectural Aluminum Manufacturers Association (AAMA), Insulating Glass Certification Council (IGCC) and National Sunroom Association (NSA) standards. Costs include supervision of installation by a manufacturer's representative. Sunrooms, solariums and conservatories have distinct definitions under most building codes. Smaller units in high wind or snow load climates will cost more than larger units built in moderate climates.

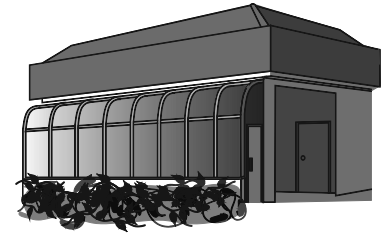

Three-season sunrooms and solariums have one twin-door single-pivot or double-hung external door and a movable sliding glass egress panel, fixed glass roof and sidewall panels and one movable screen panel. Structural main frame sections are 4-1/4" extruded 6060, 6063, 6061, 6005 or 6105 aluminum alloy with "teardrop" drip channels. Glazed with either Lexan, GE Plastics polycarbonate or equal bronze- or blue-tinted or clear glass.

Four-season sunrooms, solariums and conservatories have, in addition, minimum 3" thick compound foam sealing inside structural tubular elements and twin-pane tempered glass either gas-filled or DuPont Butacite-interlayered. Sunrooms (residential lean-to patio enclosure), three-season, no engineering required. Costs will vary with the wind load and snow load. Cost per square foot of floor.

Minimum cost, per SF	—	SF	—	—	163.00
Typical maximum cost per SF	—	SF	—	—	225.00
Add for four-season sunrooms	—	%	—	—	20.0

Residential three-season solarium. Custom-designed and engineered for the site. Cost per square foot of floor.

Minimum cost per SF	—	SF	—	—	309.00
Typical maximum cost per SF	—	SF	—	—	388.00

Residential four-season solarium, with electric service, HVAC, fireproofing and abrasion-resistant protective coating. Meets code requirements for a room addition. Cost per square foot of floor.

Minimum cost per SF	—	SF	—	—	516.00
Typical maximum cost per SF	—	SF	—	—	775.00

Residential conservatory (room addition). Four season. Stepped, bull-nose or gabled roof meets code requirements for glazed roof deflection and load. With electric service, HVAC, fireproofing, abrasion-resistant protective coating.

Minimum cost per SF	—	SF	—	—	646.00
Typical maximum cost per SF	—	SF	—	—	1,170.00

Commercial solarium, four season, with electric service, HVAC, fireproofing, abrasion-resistant protective coating, store-type doors, locksets and closers. A sidewalk café or retail facility will usually require high-impact (falling object) glazing, fire sprinklers and alarms. Cost per square foot of floor.

Typical cost per SF	—	SF	—	—	904.00
Sidewalk café or retail application, cost per SF	—	SF	—	—	1,960.00

13 Special Construction

	Craft@Hrs	Unit	Material	Labor	Total
Residential polycarbonate sheet glazing, 4' x 8' panels, Lexan, GE Plastics, or equal, for sunroom and 3-season service only.					
Clear 1/4"	G1@.027	SF	13.90	1.32	15.22
Clear 1/2"	G1@.035	SF	21.70	1.71	23.41
Add for tints	—	%	17.0	—	—
Add for hurricane and/or heavy snow load zones	—	%	25.0	—	—
Add for continuous-length custom glazing	—	%	20.0	—	—
Tempered glass, residential argon gas-filled twin-sheet Low-E glazing. PPG or equal, for 3-season and 4-season service.					
Clear, 5/8"	G1@.027	SF	21.00	1.32	22.32
Clear, 1"	G1@.035	SF	22.90	1.71	24.61
Add for tints	—	%	17.0	—	—
Add for hurricane and/or heavy snow load zones	—	%	25.0	—	—
Add for continuous-length custom glazing	—	%	20.0	—	—
High-impact sheet glazing, four-season, for conservatory and urban commercial service (tempered Low-E, PPG or equal) twin pane with DuPont Butacite interlayer. Certified for hurricane and heavy snow load.					
Clear, 5/8"	G1@.035	SF	29.40	1.71	31.11
Clear, 1"	G1@.045	SF	32.00	2.20	34.20
Add for tints	—	%	17.0	—	—
Add for curved eaves	—	%	5.0	—	—
Add for continuous-length custom glazing	—	%	20.0	—	—
Architectural aluminum structural elements					
Framing and joiner tube, 11 ga. x 1" x 3",	IW@.009	Lb	1.55	.60	2.15
Horizontal roof supports, 11 ga. x 4-1/4" x 4-1/4", with galvanized steel internal bracing	IW@.019	Lb	2.58	1.27	3.85
Vertical sidewall supports, 10 ga. x 4-1/4" x 4-1/4", with galvanized steel internal bracing	IW@.061	Lb	16.60	4.07	20.67
Add for 3" insulating foam (4-season units)	—	%	15.0	—	—
Concrete-embedded aluminum					
Light, to 20 lbs per LF	T3@.042	Lb	3.15	2.26	5.41
Medium, over 20 to 50 lbs per LF	T3@.035	Lb	2.81	1.88	4.69
Heavy, over 50 lbs per LF	T3@.025	Lb	2.40	1.34	3.74
Channel sill, 1/8" aluminum, 1-1/2" x 8" wide	T3@.131	LF	24.50	7.04	31.54
Angle sill, 1/8" aluminum, 1-1/2" x 1-1/2"	T3@.095	LF	7.73	5.10	12.83
Solariums or conservatory foundation, including forms, 3,000 p.s.i. concrete and finishing					
Footing 12" wide x 18" deep (0.058 CY per LF)	B4@.104	LF	10.50	3.93	14.43
Slab 6" thick, per SF or floor area	B5@.071	SF	4.01	2.65	6.66
Mount pre-fabricated aluminum frame	IW@.061	Lb	16.60	4.07	20.67
Allow for anchor bolts and leveling each 10' wall section	D4@4.00	Ea	206.00	192.00	398.00
Solarium or conservatory HVAC ducting					
Duct to the attached building, including plenums, crosses, tees, and air handler tie-in, per LF of duct	T6@0.03	LF	.97	1.64	2.61
Mount and connect electric service and lighting for a solarium or conservatory, including main breaker box tie-in					
Internal lighting, electric service, and wall switches, per LF of conduit	E2@.184	LF	.83	9.45	10.28
Fourth wall fabrication for a solarium or conservatory, including support frame fabrication and joist bolstering, with caulking and galvanized rain seal flashing					
Cut and fabricate wall opening	P9@.05	SF	1.33	2.45	3.78
Add for permitting and inspection	—	%	—	3.0	—

13 Special Construction

Craft@Hrs Unit Material Labor Equipment Total

Pre-Engineered Steel Buildings Vertical wall gable roof 26 gauge colored galvanized steel roof and siding with 4 in 12 (20 pound live load) roof. Cost per SF of floor area. These costs do not include foundation or floor slab. Add the cost of delivery to the site. Equipment is a 15 ton hydraulic crane and a 2-ton truck equipped for work of this type.

40' x 100' (4,000 SF)						
14' eave height	H5@.081	SF	10.90	4.45	1.43	16.78
16' eave height	H5@.089	SF	12.20	4.89	1.57	18.66
20' eave height	H5@.102	SF	13.80	5.60	1.80	21.20
60' x 100' (6,000 SF)						
14' eave height	H5@.076	SF	10.50	4.17	1.34	16.01
16' eave height	H5@.078	SF	10.70	4.28	1.38	16.36
20' eave height	H5@.089	SF	12.50	4.89	1.57	18.96
80' x 100' (8,000 SF)						
14' eave height	H5@.076	SF	10.30	4.17	1.34	15.81
16' eave height	H5@.078	SF	10.70	4.28	1.38	16.36
20' eave height	H5@.088	SF	12.50	4.83	1.55	18.88
100' x 100' (10,000 SF)						
14' eave height	H5@.074	SF	10.20	4.06	1.31	15.57
16' eave height	H5@.078	SF	10.70	4.28	1.38	16.36
20' eave height	H5@.088	SF	12.00	4.83	1.55	18.38
100' x 150' (15,000 SF)						
14' eave height	H5@.072	SF	8.72	3.95	1.27	13.94
16' eave height	H5@.076	SF	9.31	4.17	1.34	14.82
20' eave height	H5@.081	SF	10.30	4.45	1.43	16.18
100' x 200' (20,000 SF)						
14' eave height	H5@.069	SF	8.49	3.79	1.22	13.50
16' eave height	H5@.073	SF	8.90	4.01	1.29	14.20
20' eave height	H5@.078	SF	9.63	4.28	1.38	15.29
140' x 150' (21,000 SF)						
14' eave height	H5@.064	SF	7.89	3.51	1.13	12.53
16' eave height	H5@.065	SF	8.16	3.57	1.15	12.88
20' eave height	H5@.073	SF	9.14	4.01	1.29	14.44
140' x 175' (24,500 SF)						
14' eave height	H5@.063	SF	7.62	3.46	1.11	12.19
16' eave height	H5@.064	SF	7.89	3.51	1.13	12.53
20' eave height	H5@.072	SF	8.72	3.95	1.27	13.94
160' x 200' (32,000 SF)						
14' eave height	H5@.061	SF	7.44	3.35	1.08	11.87
16' eave height	H5@.062	SF	7.62	3.41	1.09	12.12
20' eave height	H5@.067	SF	8.38	3.68	1.18	13.24
200' x 200' (40,000 SF)						
14' eave height	H5@.057	SF	7.19	3.13	1.01	11.33
16' eave height	H5@.058	SF	7.36	3.19	1.02	11.57
20' eave height	H5@.064	SF	7.89	3.51	1.13	12.53
Deduct for arched roof:						
Quonset hut design	—	%	-25.0	-10.0	-10.0	—
Additional costs:						
Personnel door, 3'0" x 6'8"	H5@2.83	Ea	645.00	155.00	50.00	850.00
Overhead door, 8'0" x 8'0"	H5@8.02	Ea	2,020.00	440.00	142.00	2,602.00
Interior liner panel, 26 gauge Per SF of wall	H5@.012	SF	2.10	.66	.21	2.97

13 Special Construction

	Craft@Hrs	Unit	Material	Labor	Equipment	Total
Foam insulated sandwich panel roofing and siding Per SF of roof and sidewall	H5@.005	SF	5.82	.27	.09	6.18
Plastic skylight roof panel Per SF of panel	H5@.013	SF	6.37	.71	.23	7.31
R-11 blanket insulation, 3-1/2", wall or floor	H5@.005	SF	.49	.27	.09	.85
Ridge ventilator, 9" throat	H5@.193	LF	53.60	10.60	3.41	67.61
24 gauge colored eave gutter	H5@.028	LF	12.00	1.54	.49	14.03
4" x 4" colored downspouts	H5@.014	LF	10.30	.77	.25	11.32
30 pound live load roof design	—	%	12.0	—	—	—

	Craft@Hrs	Unit	Material	Labor	Total
--	-----------	------	----------	-------	-------

X-Ray Viewing Panels, Clear Lead-Plastic Based on SF of panel (rounded up to the next higher whole square foot). For panels 12 square feet or larger, add a crating charge. Panels larger than 72" x 96" are special order items. Weights shown are approximate.

7mm thick, 0.3mm lead equivalence, 2.3 lbs/SF	G1@.115	SF	128.00	5.62	133.62
12mm thick, 0.5mm lead equivalence, 3.9 lbs/SF	G1@.195	SF	172.00	9.53	181.53
18mm thick, 0.8mm lead equivalence, 5.9 lbs/SF	G1@.294	SF	186.00	14.40	200.40
22mm thick, 1.0mm lead equivalence, 7.2 lbs/SF	G1@.361	SF	197.00	17.60	214.60
35mm thick, 1.5mm lead equivalence, 11.5 lbs/SF	G1@.574	SF	214.00	28.00	242.00
46mm thick, 2.0mm lead equivalence, 15.0 lbs/SF	G1@.751	SF	290.00	36.70	326.70
70mm thick, 3.0mm lead equivalence, 18.0 lbs/SF	G1@1.00	SF	410.00	48.90	458.90
Crating charge	—	Ea	—	—	100.00

Mobile X-Ray Barriers Clear lead-plastic window panels on the upper portion and opaque panels on the lower portion, mounted within a framework with casters on the bottom. Labor shown is to uncrate factory assembled barrier and attach casters.

30" W x 75" H overall

2.0mm lead equiv. window panel 10" x 12" and 2.0mm lead equiv. opaque panel	MW@.501	Ea	1,540.00	27.20	1,567.20
2.0mm lead equiv. window panel 30" x 24" and 2.0mm lead equiv. opaque panel 30" x 48"	MW@.501	Ea	2,700.00	27.20	2,727.20
2.0mm lead equiv. window panel 60" x 30" and 2.0mm lead equiv. opaque panel 12" x 30"	MW@.501	Ea	3,610.00	27.20	3,637.20

48" W x 72" H overall

2.0mm lead equiv. window panel 48" x 36" and 2.0mm lead equiv. opaque panel 48" x 36"	MW@.501	Ea	5,000.00	27.20	5,027.20
---	---------	----	----------	-------	----------

72" W x 75" H, overall

2.0mm lead equiv. window panel 72" x 36" and 2.0mm lead equiv. opaque panel 72" x 36"	MW@.751	Ea	6,290.00	40.80	6,330.80
---	---------	----	----------	-------	----------

Modular X-Ray Barriers Panels are mounted within a framework for attaching to floor, wall or ceiling. Shipped unassembled. Structural supports not included. Costs shown are based on typical 36" wide x 84" high panel sections. Clear lead-plastic window panels 48" high are the upper portion and opaque leaded panels 36" high are the bottom portion.

1-section barrier, 36" W x 84" H overall

0.5mm lead equiv. panels	G1@2.78	Ea	2,930.00	136.00	3,066.00
0.8mm lead equiv. panels	G1@2.78	Ea	3,110.00	136.00	3,246.00
1.0mm lead equiv. panels	G1@3.34	Ea	3,180.00	163.00	3,343.00
1.5mm lead equiv. panels	G1@4.46	Ea	3,430.00	218.00	3,648.00

13 Special Construction

	Craft@Hrs	Unit	Material	Labor	Total
2-section barrier, 72" W x 84" H overall					
0.5mm lead equiv. panels	G1@5.56	Ea	6,240.00	272.00	6,512.00
0.8mm lead equiv. panels	G1@5.56	Ea	6,580.00	272.00	6,852.00
1.0mm lead equiv. panels	G1@6.68	Ea	6,720.00	326.00	7,046.00
1.5mm lead equiv. panels	G1@8.90	Ea	7,230.00	435.00	7,665.00
3-section barrier, 108" W x 84" H overall					
0.5mm lead equiv. panels	G1@8.34	Ea	9,550.00	407.00	9,957.00
0.8mm lead equiv. panels	G1@8.34	Ea	10,100.00	407.00	10,507.00
1.0mm lead equiv. panels	G1@10.0	Ea	10,400.00	489.00	10,889.00
1.5mm lead equiv. panels	G1@13.4	Ea	11,100.00	655.00	11,755.00
Larger than 3-section barriers, add to the cost of 1-section barriers for each section over 3					
Add per 18" W x 84" H section	—	%	50.0	—	—
Add per 36" W x 84" H section	—	%	100.0	—	—

Convenience Store Specialties

Convenience store display shelving, open glass with stainless steel frame, shell and shelves. Fluorescent indirect lighting on unit rear wall, 60 Hz, single phase, 110 Volt. Prehung slide-in label and pricing panels. Underwriters Laboratories and CSA approved.

38" wide 2-tower unit	C8@.250	Ea	1,170.00	11.90	1,181.90
72" wide 4-tower unit	C8@.350	Ea	1,610.00	16.70	1,626.70

Convenience store external signage, all-weather internally illuminated, freestanding, with internal fluorescent lighting fixtures, custom painted Lucite 48" x 72" twin-sided sign panel, structural aluminum welded frame and retainer moldings, 30 foot high by 16" diameter structural brushed and anodized aluminum vertical mounting post and reinforced base plate. Includes photocell-actuated night switch and in-store manual actuation override fused control panel. Add the cost of concrete pad, trenching, underground wiring from the electrical panel and crane rental.

Metal base plate	C8@1.50	Ea	818.00	71.40	889.40
Post and sign, installed	C8@3.00	Ea	6,940.00	143.00	7,083.00
Sign controls	C8@8.00	Ea	365.00	381.00	746.00

High-traffic convenience store aluminum twin-door portal, steel frame, pre-hung, with pneumatic adjustable closers, security deadbolt lockset, push bars both sides or "U"-section push/pull handgrips, swing-down swivel hold-open stanchions, clear glass single pane high impact tempered door glass.

Store glass double door, per pair of doors	SW@8.00	Ea	3,310.00	340.00	3,650.00
--	---------	----	----------	--------	----------

Convenience store display window security grillwork. After-hours anti-forced entry lockable grillwork, painted carbon steel horizontally-expanding accordion type, shop fabricated, 8' high by 20' long, with anchored tracking bars top and bottom.

Security grillwork, 8' x 20'	B9@8.00	Ea	1,260.00	267.00	1,527.00
Security grillwork, per SF	B9@0.05	SF	7.89	1.67	9.56

Convenience store bulletproof cashier booth (enclosure only, installed in an existing building), single panel, counter-mounted, with product/register transfer tray ("lazy Susan" type), glazed with ballistic Lucite, 5' high by 8' long.

Bulletproof cashier booth	B9@4.00	Ea	1,780.00	133.00	1,913.00
---------------------------	---------	----	----------	--------	----------

Modular prefabricated church steeple For houses of worship seating from 500 to 1,500 congregants.

Includes 16' x 16' steeple base bolted and reinforced on a steel or wood frame, matched base plate steeple element, site-specific roof-mounted 1-1/2" diameter bolted joining plate with roof rafter and purlin support joists, lightning arrestor and #8 aluminum grounding cable with dielectric zinc grounding anchor. Labor cost includes laser leveling, vendor-supplied wind studies and roof-related load-bearing studies. Equipment cost is for a five-ton tracked spider crane and flatbed trailer truck with operator and truck driver. Add the cost of carillon speakers, special lighting, anti-bird/anti-bat nesting measures and internal access ladders, if required.

13 Special Construction

	Craft@Hrs	Unit	Material	Labor	Equipment	Total
Building of roof base plate and plate support	F5@40.0	Ea	5,850.00	1,950.00	—	7,800.00
Church steeple installation						
Steeple, bolted in and shimmed	S5@24.0	Ea	25,200.00	1,070.00	2,040.00	28,310.00
Roof flashing and roof edge seal	R3@16.0	Ea	1,170.00	755.00	—	1,925.00
Painting of steeple and trim	D7@40.0	Ea	438.00	1,910.00	—	2,348.00

Decorative ornamental fountains, interior (for shopping center and office complex atriums) and exterior (for public parks and large educational and industrial campuses). Costs are for nominal 1,300 gallon capacity 16' diameter by 1' deep precast concrete circular water reservoir pond with 6-foot diameter fountain centerpiece and spigot matrix. Costs include 110 volt, 3 phase 60 Hz 5 GPM pumps, integrated drains and recirculation piping with digital adjustable flow regulator. Add the cost of foundation and gravel sub-foundation, custom decorative bas relief fascia for reservoir pond sidewalls, fencing, associated decorative ironwork and circular walkway esplanade. Equipment cost is for a forklift for two days. No electrical service or foundation costs included.

Positioning, anchoring and Gunite sealing of pond sidewalls	CM@40.0	Ea	19,500.00	2,070.00	275.00	21,845.00
Bolting and wiring of pump and controller	CE@8.00	Ea	1,930.00	488.00	—	2,418.00
Startup and adjustment of fountain pump	CE@2.00	Ea	—	122.00	—	122.00

Traffic signal 20-foot horizontal trombone mount, with controller, emergency default override, uninterruptible power system battery pack, LED low-voltage signal lighting elements. 15-foot vertical aluminum pole mount and cast aluminum base. Meets NHTSA standards. Add the cost of breaking out existing concrete and running electric power to the site. Equipment cost is for a backhoe and stinger truck crane. Per traffic signal installed. No electrical service or foundation costs included.

Craning in, bolting and shimming						
Traffic light pole and base	B5@4.00	Ea	17,700.00	149.00	275.00	18,124.00
Electrical wiring and controls	CE@8.00	Ea	2,320.00	488.00	—	2,808.00
Calibration and test	CE@4.00	Ea	—	244.00	—	244.00

Pedestrian street crossing signal, right angle bi-directional, with LED low-wattage signal lamps, timing sequence box, SCADA or equal interconnect with central traffic controller module, with aluminum post and cast aluminum base, pedestrian high-impact manual button switches, to NHTSA standards. Add the cost of removing the existing concrete and bringing electric power to the site. Equipment is a backhoe and a stinger truck crane. Per signal installed. No electrical service or foundation costs included.

Craning in, bolting and shimming of crosswalk light and base	B5@8.00	Ea	10,100.00	299.00	275.00	10,674.00
Fixtures plus assembly	CE@4.00	Ea	1,640.00	244.00	—	1,884.00
Wiring of main breaker and timer	CE@4.00	Ea	1,550.00	244.00	—	1,794.00
Calibration and test	CE@4.00	Ea	—	244.00	—	244.00

Street lighting, metal halide and high-pressure sodium twin luminaries mounted on twin 15-foot trombone horizontal extensions. Aluminum post with cast aluminum base and photocell switch actuator. Add the cost removing any existing concrete surface and excavation. Equipment is a backhoe and a stinger truck crane. Add the cost of the foundation, electrical wiring and conduit.

Craning in and positioning of pole and base	B5@2.00	Ea	17,100.00	74.70	275.00	17,449.70
Wiring of controls and power	CE@8.00	Ea	1,940.00	488.00	—	2,428.00
Startup and adjustment	CE@4.00	Ea	—	244.00	—	244.00

Public park surveillance CCTV configuration, street lamp mounted, with 4-station DVD/CD recorder, 4-station low-light digital camera units, timed and dated image software, all-weather enclosure, power supply and control panel.

Lamp-pole mount of camera	B5@4.00	Ea	609.00	149.00	—	758.00
Power supply positioning	CE@2.00	Ea	507.00	122.00	—	629.00
Wiring of controls and digital links	CE@2.00	Ea	447.00	122.00	—	569.00
Startup and adjustment	CE@1.00	Ea	—	61.00	—	61.00

13 Special Construction

	Craft@Hrs	Unit	Material	Labor	Equipment	Total
Subway platform egress barrier Pedestrian safety barrier, grade 304L stainless steel, with bolted mounting plates, electrical gate closure, master control switch relay and manual override. To American Railroad Association standards. Add the cost of removing any existing concrete surface, electrical service and foundation.						
Gate positioning and bolting	B5@2.00	Ea	5,520.00	74.70	—	5,594.70
Wiring of controls	CE@2.00	Ea	318.00	122.00	—	440.00
Startup and adjustment	CE@1.00	Ea	—	61.00	—	61.00

Pedestrian walkway bridge Over-street fully screened pedestrian walkway bridge. Pratt, Howe or Warren type double diagonal truss bridge span element, with open grid weathering steel metal walkway, 60-foot span with twin level staircases on both ends of bridge and galvanized mesh sidewall traffic protection screening. Complies with Federal Highway Association and National Steel Bridge Association design standards. Equipment includes a backhoe and a stinger truck crane. Add the foundation cost.						
Foundation plate/upright crane-in	B5@24.0	Ea	204,000.00	897.00	552.00	205,449.00
Craning in, bolt-up and weld of span	B5@16.0	Ea	656,000.00	598.00	827.00	657,425.00
Tensioning and adjustment of stressed diagonal brace elements	B5@24.0	Ea	2,320.00	897.00	—	3,217.00
Sandblast and paint structure	PT@16.0	Ea	22,000.00	617.00	662.00	23,279.00
Mounting of protective screening	B5@24.0	Ea	157,000.00	897.00	—	157,897.00
Inspection and test	MW@16.0	Ea	—	870.00	—	870.00

	Craft@Hrs	Unit	Material	Labor	Total
--	-----------	------	----------	-------	-------

Decorative and ornamental lighting for convention centers, religious, educational and entertainment venues. Costs include vendor-supplied computer simulated lighting studies, concrete anchoring, trenching of electrical cable, main breaker, adjustable lighting array switch with digital timing actuation, calibration and aiming of installed fixtures. Add the cost of electrical service and the foundation.					
Bolting of fixtures	E4@0.50	Ea	380.00	25.70	405.70
Wiring of main breaker and timer	CE@4.00	Ea	261.00	244.00	505.00
Light aiming and calibration	E4@0.50	Ea	—	25.70	25.70

Subway and metro traffic control egress portals Includes swipe card reader, three-prong turnstile, twin 304 stainless steel stall median with maintenance doors, wiring to central controller module and lockset. Add the cost of electrical service and the foundation.					
Positioning of equipment	CE@2.00	Ea	5,750.00	122.00	5,872.00
Wiring of controls	CE@4.00	Ea	128.00	244.00	372.00
Startup and adjustment	CE@1.00	Ea	—	61.00	61.00

Magnetic metal detector for arch-type pedestrian traffic portals for schools, courthouses, airports and public safety facilities. Includes typical power supply wiring, permanent grouted and leveled cement foundation, trenched wiring, calibration, test, and operating personnel training and licensing. Installed to Department of Homeland Security and International Air Traffic Association specifications and standards. No electrical service or foundation costs included.					
Equipment and positioning	CE@2.00	Ea	16,700.00	122.00	16,822.00
Wiring of controls	CE@4.00	Ea	127.00	244.00	371.00
Startup and adjustment	CE@1.00	Ea	—	61.00	61.00

MRI parcel inspection station Magnetic resonance interference baggage inspection station for airports and public buildings. Includes foot-pedal-controlled baggage conveyor, inspection device with monitor screen, alarm matrix with emergency intercom, permanent grouted and leveled cement foundation, calibration, test and training of operation personnel. Installed to Department of Homeland Security and International Air Traffic Association specifications and standards. Add the cost of electrical service and the foundation.					
Equipment and positioning	CE@2.00	Ea	161,000.00	122.00	161,122.00
Wiring of controls	CE@2.00	Ea	214.00	122.00	336.00
Startup and adjustment	CE@1.00	Ea	—	61.00	61.00

13 Special Construction

	Craft@Hrs	Unit	Material	Labor	Total
Commercial high-definition digital cable-based FCC-licensed studio Facilities for production, post-production (editing) and broadcast. Includes architectural modifications to wall, floor and ceiling elements of a pre-existing office or warehouse structure to address standards-controlled sound mitigation and electronic spurious emissions limitation requirements. Add the cost of industry-specific television production equipment such as television cameras, mounts, lighting, microphones, recording equipment and esthetic trim such as paint and wall coverings in administration areas. Design parameters reflect compliance with standards specified by the Audio Engineering Society, Institute of Broadcast Sound, American Federation of TV and Recording Artists and the Society of Motion Picture and Television Engineers.					
Wall modifications, soundproofing					
Staggered studs	C8@.021	SF	1.54	1.00	2.54
Insulation	C8@.006	SF	0.83	.29	1.12
Specialty perfboard	C8@.007	SF	1.43	.33	1.76
Ceiling modifications, soundproofing					
Staggered joists	C8@.022	SF	1.54	1.05	2.59
Insulation	C8@.008	SF	0.83	.38	1.21
Specialty perfboard	C8@.009	SF	1.43	.43	1.86
Floor modifications (over existing slab)					
Prefab soundproof floor panels	FL@.020	SF	3.05	1.04	4.09
Acoustical mahogany parquet	FL@.020	SF	5.06	1.04	6.10
Prefab control room modules					
Harris Corporation or equal	CC@.030	SF	9.26	1.61	10.87
Scrim and lighting tracks, less scrims and lighting	E4@1.50	Ea	925.00	77.00	1,002.00
Electrical service					
Sunken outlet trays, 480 volt, three phase, 60 Hz	E4@1.00	Ea	365.00	51.30	416.30
Main electrical switchgear panel, 500 amp	E4@23.2	Ea	5,370.00	1,190.00	6,560.00
Ground fault and lightning protection	E4@16.0	Ea	1,470.00	821.00	2,291.00
Electronic control panel support framing and mounts					
Wood control panel supports, custom	C8@.256	LF	92.00	12.20	104.20
Prefab, custom, 20 gauge galvanized steel	D4@.785	LF	168.00	37.70	205.70
Control room soundproof glazing	G1@.086	SF	29.10	4.20	33.30
Uninterruptible power source					
Engine generator, 500 KW	E4@60.0	Ea	150,000.00	3,080.00	153,080.00
Radio frequency emissions screening					
Copper grounded	E4@1.16	Ea	37.70	59.60	97.30
Electrostatic discharge protective grounding	E4@1.13	Ea	34.60	58.00	92.60
Digital cable enclosure tray and connector panel					
	BE@0.50	Ea	136.00	20.50	156.50
Animation studio					
Multiple workstation cubicle gallery	C8@.028	SF	15.80	1.33	17.13

14 Conveying Equipment

Dumbwaiters These costs do not include allowance for constructing the hoistway walls or electrical work.

Manual, 2 stop, 25 feet per minute, no doors, by rated capacity, 24" x 24" x 36" high car					
25 pounds to 50 pounds	CV@39.8	Ea	3,230.00	2,300.00	5,530.00
75 pounds to 200 pounds	CV@42.7	Ea	4,410.00	2,470.00	6,880.00
Add for each additional stop	—	Ea	—	—	2,480.00

14 Conveying Equipment

	Craft@Hrs	Unit	Material	Labor	Total
Electric, with machinery mounted above, floor loading, no security gates included					
50 lbs, 25 FPM, 2 stop, no doors	CV@42.2	Ea	2,870.00	2,440.00	5,310.00
50 lbs, 25 FPM, 2 stop, manual doors	CV@106.	Ea	7,130.00	6,130.00	13,260.00
50 lbs, 50 FPM, 2 stop, manual doors	CV@107.	Ea	7,170.00	6,180.00	13,350.00
75 lbs, 25 FPM, 2 stop, no doors	CV@42.2	Ea	2,870.00	2,440.00	5,310.00
75 lbs, 25 FPM, 2 stop, manual doors	CV@107.	Ea	8,630.00	6,180.00	14,810.00
75 lbs, 50 FPM, 2 stop, manual doors	CV@111.	Ea	8,650.00	6,410.00	15,060.00
100 lbs, 25 FPM, 2 stop, no doors	CV@50.6	Ea	4,180.00	2,920.00	7,100.00
100 lbs, 25 FPM, 2 stop, manual doors	CV@107.	Ea	8,870.00	6,180.00	15,050.00
100 lbs, 50 FPM, 2 stop, manual doors	CV@111.	Ea	9,050.00	6,410.00	15,460.00
100 lbs, 100 FPM, 5 stop, manual doors	CV@162.	Ea	9,500.00	9,360.00	18,860.00
200 lbs, 25 FPM, 2 stop, no doors	CV@52.3	Ea	4,290.00	3,020.00	7,310.00
200 lbs, 25 FPM, 2 stop, manual doors	CV@111.	Ea	9,170.00	6,410.00	15,580.00
200 lbs, 100 FPM, 5 stop, manual doors	CV@162.	Ea	11,200.00	9,360.00	20,560.00
300 lbs, 50 FPM, 2 stop, manual doors	CV@113.	Ea	18,900.00	6,530.00	25,430.00
300 lbs, 100 FPM, 5 stop, manual doors	CV@171.	Ea	25,100.00	9,880.00	34,980.00
400 lbs, 50 FPM, 2 stop, manual doors	CV@114.	Ea	19,100.00	6,590.00	25,690.00
400 lbs, 100 FPM, 5 stop, manual doors	CV@174.	Ea	27,700.00	10,100.00	37,800.00
500 lbs, 50 FPM, 2 stop, manual doors	CV@117.	Ea	19,700.00	6,760.00	26,460.00
500 lbs, 100 FPM, 5 stop, manual doors	CV@178.	Ea	29,100.00	10,300.00	39,400.00

Elevators, Passenger Typical subcontract costs excluding the shaft wall, supports, ladders, roof structure, pit and electric supply. Installation costs in an existing building will be higher. Automatic exit doors.

Hydraulic, office or apartment type

100 FPM, automatic exit door, 2,000 lb. capacity					
2 stop	—	LS	—	—	70,200.00
3 stop	—	LS	—	—	79,200.00
Add for each additional stop	—	Ea	—	—	8,920.00
150 FPM, center opening doors, 2,500 lb. capacity					
2 stop	—	LS	—	—	77,000.00
3 stop	—	LS	—	—	85,300.00
Add for each additional stop	—	Ea	—	—	9,690.00
Geared passenger elevator, 200 FPM, 2,000 lb. capacity					
4 stop	—	LS	—	—	136,000.00
5 stop	—	LS	—	—	150,000.00
Add for each additional stop	—	LS	—	—	13,900.00
Gearless passenger elevator, 500 FPM, 3,500 lb. capacity					
5 stop	—	LS	—	—	193,000.00
10 stop	—	LS	—	—	267,000.00
Add for each additional stop	—	Ea	—	—	15,000.00
Gearless passenger elevator, 700 FPM, 4,500 lb. capacity					
10 stop	—	LS	—	—	273,000.00
15 stop	—	LS	—	—	354,000.00
Add for each additional stop	—	Ea	—	—	16,100.00
Gearless passenger elevator, 1000 FPM, 5,000 lb. capacity					
10 stop	—	LS	—	—	290,000.00
15 stop	—	LS	—	—	375,000.00
Add for each additional stop	—	Ea	—	—	17,100.00
Sidewalk elevators, 2 stops, 2,500 pounds	—	LS	—	—	53,000.00

14 Conveying Equipment

	Craft@Hrs	Unit	Material	Labor	Total
Elevators, Freight Hydraulic, power doors, two stops. Typical subcontract costs excluding the shaft wall, roof structure and electric supply.					
3,000 lbs. 50 FPM	—	LS	—	—	72,500.00
4,000 lbs. 50 FPM	—	LS	—	—	79,100.00
6,000 lbs. 50 FPM	—	LS	—	—	92,800.00
3,000 lbs. 100 FPM	—	LS	—	—	81,700.00
4,000 lbs. 100 FPM	—	LS	—	—	86,600.00
6,000 lbs. 100 FPM	—	LS	—	—	102,000.00
3,000 lbs. 150 FPM	—	LS	—	—	90,000.00
4,000 lbs. 150 FPM	—	LS	—	—	94,000.00
6,000 lbs. 150 FPM	—	LS	—	—	111,000.00
Add for each additional stop	—	LS	—	—	8,260.00
Moving Stairs and Walks Typical subcontract prices.					
Escalators, 90 FPM, steel trim, 32" step width, glass balustrade					
13' rise	—	Ea	—	—	156,000.00
15' rise	—	Ea	—	—	155,000.00
17' rise	—	Ea	—	—	162,000.00
19' rise	—	Ea	—	—	167,000.00
21' rise	—	Ea	—	—	194,000.00
Add for 48" width	—	%	—	—	5.0
Add for stainless balustrade	—	%	—	—	8.0
Hoists and Cranes These costs do not include electrical work.					
Electric hoists, manual trolley, 20 FPM lift. Add cost of monorail below					
1/2 ton, swivel mount, 25' lift	D4@9.34	Ea	6,030.00	449.00	6,479.00
1/2 ton, swivel mount, 45' lift	D4@13.7	Ea	6,390.00	658.00	7,048.00
1/2 ton, swivel mount, 75' lift	D4@18.0	Ea	7,150.00	865.00	8,015.00
1 ton, geared trolley, 20' lift	D4@11.9	Ea	7,240.00	572.00	7,812.00
1 ton, geared trolley, 30' lift	D4@15.8	Ea	7,640.00	759.00	8,399.00
1 ton, geared trolley, 55' lift	D4@19.2	Ea	8,390.00	922.00	9,312.00
2 ton, geared trolley, 15' lift	D4@15.8	Ea	8,850.00	759.00	9,609.00
2 ton, geared trolley, 35' lift	D4@15.8	Ea	9,390.00	759.00	10,149.00
2 ton, geared trolley, 55' lift	D4@15.8	Ea	10,200.00	759.00	10,959.00
2 ton, geared trolley, 70' lift	D4@15.8	Ea	10,700.00	759.00	11,459.00
Electric hoists, power trolley, 20 FPM trolley speed. Add cost of monorail from below					
1/2 ton, 50 FPM lift to 25'	D4@8.94	Ea	7,150.00	429.00	7,579.00
1/2 ton, 100 FPM lift to 25'	D4@15.8	Ea	10,500.00	759.00	11,259.00
1/2 ton, 50 FPM lift to 45'	D4@8.94	Ea	7,520.00	429.00	7,949.00
1/2 ton, 100 FPM lift to 45'	D4@15.8	Ea	11,000.00	759.00	11,759.00
1/2 ton, 50 FPM lift to 75'	D4@11.9	Ea	8,240.00	572.00	8,812.00
1/2 ton, 100 FPM lift to 75'	D4@18.0	Ea	11,600.00	865.00	12,465.00
1 ton, 50 FPM lift to 20'	D4@15.8	Ea	7,280.00	759.00	8,039.00
1 ton, 50 FPM lift to 30'	D4@15.8	Ea	7,710.00	759.00	8,469.00
1 ton, 50 FPM lift to 55'	D4@18.0	Ea	8,550.00	865.00	9,415.00
2 ton, 50 FPM lift to 15'	D4@17.9	Ea	8,760.00	860.00	9,620.00
2 ton, 50 FPM lift to 35'	D4@19.9	Ea	9,620.00	956.00	10,576.00
2 ton, 50 FPM lift to 55'	D4@19.9	Ea	10,300.00	956.00	11,256.00
2 ton, 50 FPM lift to 70'	D4@19.9	Ea	10,400.00	956.00	11,356.00
Monorail for electric hoists, channel type					
100 pounds per LF	D4@.443	LF	14.00	21.30	35.30
200 pounds per LF	D4@.555	LF	22.00	26.70	48.70
300 pounds per LF	D4@.761	LF	32.80	36.60	69.40

14 Conveying Equipment

	Craft@Hrs	Unit	Material	Labor	Total
Jib cranes, self-supporting, swinging 8' boom, 220 degree rotation					
1,000 pounds	D4@7.90	Ea	2,250.00	379.00	2,629.00
2,000 pounds	D4@11.9	Ea	2,400.00	572.00	2,972.00
3,000 pounds	D4@13.5	Ea	2,680.00	648.00	3,328.00
4,000 pounds	D4@13.5	Ea	3,190.00	648.00	3,838.00
6,000 pounds	D4@15.8	Ea	3,380.00	759.00	4,139.00
10,000 pounds	D4@19.7	Ea	4,590.00	946.00	5,536.00
Jib cranes, wall mounted, swinging 8' boom, 180 degree rotation					
1,000 pounds	D4@8.19	Ea	1,200.00	393.00	1,593.00
2,000 pounds	D4@13.5	Ea	1,310.00	648.00	1,958.00
4,000 pounds	D4@13.5	Ea	1,970.00	648.00	2,618.00
6,000 pounds	D4@15.8	Ea	2,250.00	759.00	3,009.00
10,000 pounds	D4@19.7	Ea	4,090.00	946.00	5,036.00

Material Handling Systems

Conveyors, typical subcontract price. Foundations, support structures and electrical work not included

Belt type, 24" width	—	LF	—	—	270.00
Mail conveyors, automatic, electronic					
Horizontal	—	LF	—	—	2,320.00
Vertical, per 12' floor	—	Ea	—	—	29,600.00

Chutes, linen or solid waste handling, prefabricated unit including roof vent, 1-1/2 hour "B" rated doors, discharge and sprinkler system, gravity feed. Costs shown are for each floor based on 8' to 10' floor to floor height.

Light duty, aluminum, 20" diameter	D4@5.85	Ea	1,400.00	281.00	1,681.00
Standard, 18-gauge steel, 24" diameter	D4@5.85	Ea	1,560.00	281.00	1,841.00
Standard, 18-gauge steel, 30" diameter	D4@5.85	Ea	1,870.00	281.00	2,151.00
Heavy duty, 18-gauge stainless steel					
24" diameter	D4@5.85	Ea	2,340.00	281.00	2,621.00
30" diameter	D4@5.85	Ea	2,490.00	281.00	2,771.00
Manual door with stainless steel rim	D4@2.17	Ea	783.00	104.00	887.00
Disinfecting and sanitizing unit	D4@2.17	Ea	309.00	104.00	413.00
Discharge storage unit					
Aluminum	D4@1.00	Ea	1,400.00	48.00	1,448.00
Stainless steel	D4@1.00	Ea	2,130.00	48.00	2,178.00

Pneumatic Tube Systems Typical subcontract prices.

3" diameter, two station, single pipe,					
100' between stations	—	LS	—	—	9,640.00
3" diameter, two station, twin pipe,					
100' between stations	—	LS	—	—	12,100.00

21 Fire Suppression

Sprinkler systems Typical subcontract prices including the subcontractor's overhead and profit. These costs include design drawings, valves and connection to piping to within 5'0" outside the building. Costs will be higher where room sizes are smaller or where coverage per head averages less than 110 SF. Make additional allowances if a booster pump is required.

Exposed systems, wet, complete, cost per SF of floor protected

5,000 SF	—	SF	—	—	5.27
Over 5,000 to 15,000 SF	—	SF	—	—	4.19
15,000 SF or more	—	SF	—	—	3.75

21 Fire Suppression

	Craft@Hrs	Unit	Material	Labor	Total
Concealed systems, wet, complete, cost per SF of floor protected					
5,000 SF	—	SF	—	—	4.91
Over 5,000 to 15,000 SF	—	SF	—	—	4.22
Over 15,000 SF	—	SF	—	—	3.32
Add for dry systems	—	%	—	—	20.0
Fire sprinkler system components Add the cost of shutting down and draining the system if required					
Sprinkler heads only (remove and replace)					
Brass pendent or upright head, 155-200 degree	SP@.350	Ea	8.07	22.90	30.97
Brass pendent or upright head, 286 degree	SP@.350	Ea	8.07	22.90	30.97
Brass pendent or upright head, 360 degree	SP@.350	Ea	5.42	22.90	28.32
Brass pendent or upright head, 400-500 degree	SP@.350	Ea	24.00	22.90	46.90
Chrome pendent head, 155-286 degree	SP@.350	Ea	8.63	22.90	31.53
Chrome upright head, 155-286 degree	SP@.350	Ea	20.20	22.90	43.10
Dry pendent or upright head	SP@.350	Ea	22.40	22.90	45.30
Relocate wet sprinkler head and branch drop	SP@1.50	Ea	42.50	98.20	140.70
Add for heads more than 14' above floor	—	%	—	20.0	—
Wet system components (where freezing is not a hazard)					
Zone valves					
2-1/2" OS&Y gate valve, flanged or grooved	SP@1.75	Ea	393.00	115.00	508.00
3" OS&Y gate valve, flanged or grooved	SP@2.00	Ea	413.00	131.00	544.00
4" OS&Y gate valve, flanged or grooved	SP@2.25	Ea	478.00	147.00	625.00
6" OS&Y gate valve, flanged or grooved	SP@3.00	Ea	734.00	196.00	930.00
8" OS&Y gate valve, flanged or grooved	SP@3.50	Ea	1,170.00	229.00	1,399.00
4" alarm valve, flanged or grooved	SP@2.65	Ea	627.00	173.00	800.00
6" alarm valve, flanged or grooved	SP@3.50	Ea	772.00	229.00	1,001.00
8" alarm valve, flanged or grooved	SP@4.25	Ea	1,130.00	278.00	1,408.00
Alarm valve trim only (retard chamber and gauges)	SP@1.25	Ea	421.00	81.80	502.80
4" alarm valve package, complete	SP@4.00	Ea	1,970.00	262.00	2,232.00
6" alarm valve package, complete	SP@4.50	Ea	2,170.00	295.00	2,465.00
8" alarm valve package, complete	SP@5.25	Ea	2,660.00	344.00	3,004.00
Retard pressure switch	SP@1.75	Ea	393.00	115.00	508.00
Check valves					
3" swing check valve	SP@2.00	Ea	248.00	131.00	379.00
4" swing check valve	SP@2.25	Ea	221.00	147.00	368.00
6" swing check valve	SP@3.00	Ea	436.00	196.00	632.00
3" wafer check valve	SP@2.00	Ea	290.00	131.00	421.00
4" wafer check valve	SP@2.25	Ea	312.00	147.00	459.00
6" wafer check valve	SP@3.00	Ea	512.00	196.00	708.00
8" wafer check valve	SP@3.50	Ea	727.00	229.00	956.00
10" wafer check valve	SP@4.25	Ea	1,300.00	278.00	1,578.00
3" double check detector assembly	SP@3.75	Ea	3,120.00	246.00	3,366.00
4" double check detector assembly	SP@4.50	Ea	3,390.00	295.00	3,685.00
6" double check detector assembly	SP@5.75	Ea	5,320.00	376.00	5,696.00
8" double check detector assembly	SP@6.25	Ea	9,620.00	409.00	10,029.00
Dry system components (distribution piping holds no water)					
Dry valves (deluge)					
3" dry pipe valve	SP@2.25	Ea	1,170.00	147.00	1,317.00
4" dry pipe valve	SP@2.65	Ea	1,320.00	173.00	1,493.00
6" dry pipe valve	SP@3.50	Ea	1,680.00	229.00	1,909.00
Dry valve trim and gauges	SP@1.00	Ea	548.00	65.50	613.50

21 Fire Suppression

	Craft@Hrs	Unit	Material	Labor	Total
Wall hydrants for sprinkler systems, brass					
Single outlet, 2-1/2" x 2-1/2"	SP@2.00	Ea	409.00	131.00	540.00
2-way outlet, 2-1/2" x 2-1/2" x 4"	SP@2.50	Ea	660.00	164.00	824.00
3-way outlet, 2-1/2" x 2-1/2" x 3-1/3" x 4"	SP@2.75	Ea	1,210.00	180.00	1,390.00
Fire dept. connection, 4" (Siamese)	SP@2.50	Ea	640.00	164.00	804.00
Pumper connection, 6"	SP@3.00	Ea	1,300.00	196.00	1,496.00
Roof manifold, with valves	SP@3.90	Ea	771.00	255.00	1,026.00
Fire sprinkler system components					
Air maintenance device	SP@.781	Ea	237.00	51.10	288.10
Low air supervisory unit	SP@1.11	Ea	736.00	72.70	808.70
Low air pressure switch	SP@.784	Ea	237.00	51.30	288.30
Pressure switch (double circuit, open and close)	SP@1.92	Ea	231.00	126.00	357.00
1/2" ball drip at check valve and fire dept. connection	SP@.193	Ea	26.60	12.60	39.20
Water powered gong (local alarm)	SP@1.94	Ea	288.00	127.00	415.00
Cabinet with 6 spare heads and wrench	SP@.291	LS	111.00	19.10	130.10
Inspector's test connection	SP@.973	Ea	91.90	63.70	155.60
Escutcheon for sprinkler heads, chrome	SP@.071	Ea	1.56	4.65	6.21
Field testing and flushing, subcontract	—	LS	—	—	221.00
Disinfection of distribution system, subcontract	—	LS	—	—	221.00
Hydraulic design fee, subcontract					
Sprinklers in a high density or high risk area, typical	—	LS	—	—	3,060.00
Underground valve vault (if required), subcontract	—	LS	—	—	3,550.00
Fire hose cabinets , recessed, 24" x 30" x 5-1/2" with rack, full glass door, 1-1/2" hose, valve and nozzle. Standard.					
Painted steel, 75' hose, 24" x 30"	SP@1.95	Ea	577.00	128.00	705.00
Painted steel, 100' hose, 24" x 36"	SP@1.95	Ea	579.00	128.00	707.00
Aluminum, 75' hose	SP@1.95	Ea	793.00	128.00	921.00
Stainless steel, 75' hose	SP@1.95	Ea	1,030.00	128.00	1,158.00
Fire extinguishers Factory charged, complete with hose and horn and wall mounting bracket					
5 lb. carbon dioxide	C8@.488	Ea	67.00	23.20	90.20
10 lb. carbon dioxide	C8@.488	Ea	98.00	23.20	121.20
20 lb. carbon dioxide	C8@.488	Ea	170.00	23.20	193.20
5 lb. Halotron	C8@.488	Ea	203.00	23.20	226.20
11 lb. Halotron	C8@.488	Ea	408.00	23.20	431.20
15.5 lb. Halotron	C8@.488	Ea	639.00	23.20	662.20
Deduct for quantity purchase	—	%	-15.0	—	—
Extinguisher cabinets No extinguishers included, painted steel, recessed					
9" x 24" x 5" full glass door	C8@1.67	Ea	156.00	79.50	235.50
9" x 24" x 5" break glass door	C8@1.67	Ea	186.00	79.50	265.50
12" x 27" x 8" full glass door	C8@1.67	Ea	181.00	79.50	260.50
12" x 27" x 8" break glass door	C8@1.67	Ea	214.00	79.50	293.50
Add for semi-recessed or surface mount	—	%	10.0	—	—
Add for chrome cabinets	—	%	15.0	—	—
Add for stainless steel cabinets	—	Ea	226.00	—	226.00

22 Plumbing

	Craft@Hrs	Unit	Material	Labor	Total
Carbon Steel Pipe and Fittings (Black Steel) Pipe is ERW – A53 (electric resistance welded) with a factory-welded seam. Installation heights indicate the working height above the building floor. Assembly costs include hangers as required for the pipe diameter, a reducing tee and an elbow each 16 feet for 1/2" pipe, to each 50 feet for 12" pipe. For more detailed coverage, see <i>National Plumbing & HVAC Estimator</i> , https://craftsman-book.com/national-estimator-cloud .					
1/2" carbon steel (A53) threaded pipe and fittings					
Pipe, no fittings or supports included, 1/2", threaded ends					
Schedule 40 to 10' high	M5@.060	LF	2.23	3.14	5.37
Schedule 40 over 10' to 20'	M5@.070	LF	2.23	3.67	5.90
Schedule 80 to 10' high	M5@.070	LF	3.77	3.67	7.44
Schedule 80 over 10' to 20'	M5@.080	LF	3.77	4.19	7.96
Pipe assembly, Schedule 40, fittings, hangers and supports	M5@.130	LF	2.71	6.81	9.52
Add for seamless pipe (A106)	—	%	50.0	—	—
90-degree ells, 1/2", threaded					
150 lb, malleable iron	M5@.120	Ea	1.60	6.28	7.88
300 lb, malleable iron	M5@.132	Ea	8.82	6.91	15.73
45-degree ells, 1/2", threaded					
150 lb, malleable iron	M5@.120	Ea	2.17	6.28	8.45
300 lb, malleable iron	M5@.132	Ea	9.66	6.91	16.57
Tees, 1/2", threaded					
150 lb, malleable iron	M5@.180	Ea	2.11	9.43	11.54
300 lb, malleable iron	M5@.198	Ea	12.40	10.40	22.80
150 lb, reducing, malleable iron	M5@.170	Ea	3.02	8.90	11.92
300 lb, reducing, malleable iron	M5@.180	Ea	11.50	9.43	20.93
Caps, 1/2" threaded					
150 lb, malleable iron	M5@.090	Ea	1.52	4.71	6.23
300 lb, malleable iron	M5@.100	Ea	5.58	5.24	10.82
Couplings, 1/2" threaded					
150 lb, malleable iron	M5@.120	Ea	1.92	6.28	8.20
300 lb, malleable iron	M5@.132	Ea	5.94	6.91	12.85
Flanges, forged steel, 1/2"					
150 lb, threaded flange	M5@.489	Ea	17.40	25.60	43.00
300 lb, threaded flange	M5@.781	Ea	22.40	40.90	63.30
600 lb, threaded flange	M5@.859	Ea	78.10	45.00	123.10
Unions, 1/2"					
150 lb, malleable iron	M5@.140	Ea	6.55	7.33	13.88
300 lb, malleable iron	M5@.150	Ea	10.20	7.86	18.06
Add for galvanized 1/2" pipe	—	%	32.0	—	—
Add for galvanized 1/2" 150 lb. malleable fittings	—	%	15.0	—	—
Add for galvanized 1/2" 300 lb. malleable fittings	—	%	55.0	—	—
Add for galvanized 1/2" pipe assembly, Schedule 40	—	%	25.0	—	—
3/4" carbon steel (A53) threaded pipe and fittings					
Pipe, no fittings or supports included, 3/4", threaded					
Schedule 40 to 10' high	M5@.070	LF	2.89	3.67	6.56
Schedule 40 over 10' to 20'	M5@.080	LF	2.89	4.19	7.08
Schedule 80 to 10' high	M5@.080	LF	5.41	4.19	9.60
Schedule 80 over 10' to 20'	M5@.095	LF	5.41	4.98	10.39

22 Plumbing

	Craft@Hrs	Unit	Material	Labor	Total
Pipe assembly, Schedule 40, fittings, hangers and supports	M5@.140	LF	3.40	7.33	10.73
Add for seamless pipe (A106)	—	%	55.0	—	—
90-degree ells, 3/4" threaded					
150 lb, malleable iron	M5@.130	Ea	2.00	6.81	8.81
300 lb, malleable iron	M5@.143	Ea	10.40	7.49	17.89
45-degree ells, 3/4" threaded					
150 lb, malleable iron	M5@.130	Ea	2.85	6.81	9.66
300 lb, malleable iron	M5@.143	Ea	11.50	7.49	18.99
Tees, 3/4" threaded					
150 lb, malleable iron	M5@.190	Ea	2.94	9.95	12.89
300 lb, malleable iron	M5@.209	Ea	13.10	10.90	24.00
150 lb, reducing, malleable iron	M5@.180	Ea	3.97	9.43	13.40
300 lb, reducing, malleable iron	M5@.205	Ea	14.70	10.70	25.40
Caps, 3/4" threaded					
150 lb, malleable iron	M5@.100	Ea	2.01	5.24	7.25
300 lb, malleable iron	M5@.110	Ea	7.44	5.76	13.20
Couplings, 3/4" threaded					
150 lb, malleable iron	M5@.130	Ea	2.32	6.81	9.13
300 lb, malleable iron	M5@.143	Ea	7.02	7.49	14.51
Unions, 3/4"					
150 lb, malleable iron	M5@.150	Ea	8.35	7.86	16.21
300 lb, malleable iron	M5@.165	Ea	12.90	8.64	21.54
Flanges, forged steel, 3/4"					
150 lb, threaded flange	M5@.585	Ea	6.16	30.60	36.76
300 lb, threaded flange	M5@.781	Ea	22.50	40.90	63.40
600 lb, threaded flange	M5@.859	Ea	72.90	45.00	117.90
Add for galvanized 3/4" pipe	—	%	32.0	—	—
Add for galvanized 3/4" 150 lb. malleable fittings	—	%	25.0	—	—
Add for galvanized 3/4" 300 lb. malleable fittings	—	%	55.0	—	—
Add for galvanized 3/4" pipe assembly, Schedule 40	—	%	30.0	—	—
1" carbon steel (A53) threaded pipe and fittings					
Pipe, no fittings or supports included, 1", threaded					
Schedule 40 to 10' high	M5@.090	LF	3.27	4.71	7.98
Schedule 40 over 10' to 20'	M5@.110	LF	3.27	5.76	9.03
Schedule 80 to 10' high	M5@.100	LF	5.48	5.24	10.72
Schedule 80 over 10' to 20'	M5@.120	LF	5.48	6.28	11.76
Pipe assembly, Schedule 40, fittings, hangers and supports	M5@.160	LF	4.04	8.38	12.42
Add for seamless pipe (A106)	—	%	50.0	—	—
90-degree ells, 1" threaded					
150 lb, malleable iron	M5@.180	Ea	3.00	9.43	12.43
300 lb, malleable iron	M5@.198	Ea	11.60	10.40	22.00
45-degree ells, 1" threaded					
150 lb, malleable iron	M5@.180	Ea	3.62	9.43	13.05
300 lb, malleable iron	M5@.198	Ea	12.70	10.40	23.10
Tees, 1" threaded					
150 lb, malleable iron	M5@.230	Ea	4.34	12.00	16.34
300 lb, malleable iron	M5@.253	Ea	13.60	13.20	26.80
150 lb, reducing, malleable iron	M5@.205	Ea	5.77	10.70	16.47
300 lb, reducing, malleable iron	M5@.220	Ea	16.10	11.50	27.60

22 Plumbing

	Craft@Hrs	Unit	Material	Labor	Total
Caps, 1" threaded					
150 lb, malleable iron	M5@.140	Ea	2.68	7.33	10.01
300 lb, malleable iron	M5@.155	Ea	10.20	8.12	18.32
Couplings, 1" threaded					
150 lb, malleable iron	M5@.180	Ea	3.40	9.43	12.83
300 lb, malleable iron	M5@.198	Ea	8.05	10.40	18.45
Flanges, forged steel, 1"					
150 lb, threaded flange	M5@.731	Ea	16.30	38.30	54.60
300 lb, threaded flange	M5@1.05	Ea	27.10	55.00	82.10
600 lb, threaded flange	M5@1.15	Ea	78.60	60.20	138.80
Unions, 1"					
150 lb, malleable iron	M5@.210	Ea	10.40	11.00	21.40
300 lb, malleable iron	M5@.230	Ea	26.00	12.00	38.00
Add for galvanized 1" pipe	—	%	32.0	—	—
Add for galvanized 1" 150 lb. malleable fittings	—	%	20.0	—	—
Add for galvanized 1" 300 lb. malleable fittings	—	%	60.0	—	—
Add for galvanized 1" pipe assembly, Schedule 40	—	%	30.0	—	—
1-1/4" carbon steel (A53) threaded pipe and fittings					
Pipe, no fittings or supports included, 1-1/4", threaded					
Schedule 40 to 10' high	M5@.100	LF	3.69	5.24	8.93
Schedule 40 over 10' to 20'	M5@.120	LF	3.69	6.28	9.97
Schedule 80 to 10' high	M5@.110	LF	6.25	5.76	12.01
Schedule 80 over 10' to 20'	M5@.130	LF	6.25	6.81	13.06
Pipe assembly, Schedule 40, fittings, hangers and supports	M5@.200	LF	4.83	10.50	15.33
Add for seamless pipe (A106)	—	%	45.0	—	—
90-degree ells, 1-1/4" threaded					
150 lb, malleable iron	M5@.240	Ea	5.54	12.60	18.14
300 lb, malleable iron	M5@.264	Ea	18.20	13.80	32.00
45-degree ells, 1-1/4" threaded					
150 lb, malleable iron	M5@.240	Ea	7.13	12.60	19.73
300 lb, malleable iron	M5@.264	Ea	13.80	13.80	27.60
Tees, 1-1/4" threaded					
150 lb, malleable iron	M5@.310	Ea	7.85	16.20	24.05
300 lb, malleable iron	M5@.341	Ea	19.80	17.90	37.70
150 lb, reducing, malleable iron	M5@.290	Ea	13.10	15.20	28.30
300 lb, reducing, malleable iron	M5@.310	Ea	31.10	16.20	47.30
Caps, 1-1/4" threaded					
150 lb, malleable iron	M5@.180	Ea	3.65	9.43	13.08
300 lb, malleable iron	M5@.200	Ea	14.70	10.50	25.20
Couplings, 1-1/4" threaded					
150 lb, malleable iron	M5@.240	Ea	5.25	12.60	17.85
300 lb, malleable iron	M5@.264	Ea	11.60	13.80	25.40
Unions, 1-1/4"					
150 lb, malleable iron	M5@.280	Ea	16.00	14.70	30.70
300 lb, malleable iron	M5@.310	Ea	26.10	16.20	42.30
Flanges, forged steel, 1-1/4"					
150 lb, threaded flange	M5@.788	Ea	27.50	41.30	68.80
300 lb, threaded flange	M5@1.04	Ea	40.50	54.50	95.00
600 lb, threaded flange	M5@1.14	Ea	89.20	59.70	148.90

22 Plumbing

	Craft@Hrs	Unit	Material	Labor	Total
Add for galvanized 1-1/4" pipe	—	%	30.0	—	—
Add for galvanized 1-1/4" 150 lb. malleable fittings	—	%	20.0	—	—
Add for galvanized 1-1/4" 300 lb. malleable fittings	—	%	65.0	—	—
Add for galvanized 1-1/4" pipe assembly, Schedule 40	—	%	30.0	—	—
1-1/2" carbon steel (A53) threaded pipe and fittings					
Pipe, no fittings or supports included, 1-1/2", threaded					
Schedule 40 to 10' high	M5@.110	LF	5.51	5.76	11.27
Schedule 40 over 10' to 20'	M5@.130	LF	5.51	6.81	12.32
Schedule 80 to 10' high	M5@.120	LF	9.36	6.28	15.64
Schedule 80 over 10' to 20'	M5@.140	LF	9.36	7.33	16.69
Pipe assembly, Schedule 40, fittings, hangers and supports	M5@.230	LF	6.86	12.00	18.86
Add for seamless pipe (A106)	—	%	45.0	—	—
90-degree ells, 1-1/2" threaded					
150 lb, malleable iron	M5@.300	Ea	6.89	15.70	22.59
300 lb, malleable iron	M5@.333	Ea	20.70	17.40	38.10
45-degree ells, 1-1/2" threaded					
150 lb, malleable iron	M5@.390	Ea	6.53	20.40	26.93
300 lb, malleable iron	M5@.429	Ea	21.10	22.50	43.60
Tees, 1-1/2" threaded					
150 lb, malleable iron	M5@.390	Ea	9.76	20.40	30.16
300 lb, malleable iron	M5@.429	Ea	25.20	22.50	47.70
150 lb, reducing, malleable iron	M5@.360	Ea	18.40	18.90	37.30
300 lb, reducing, malleable iron	M5@.390	Ea	46.90	20.40	67.30
Caps, 1-1/2" threaded					
150 lb, malleable iron	M5@.230	Ea	4.64	12.00	16.64
300 lb, malleable iron	M5@.250	Ea	16.30	13.10	29.40
Couplings, 1-1/2" threaded					
150 lb, malleable iron	M5@.300	Ea	6.25	15.70	21.95
300 lb, malleable iron	M5@.330	Ea	15.50	17.30	32.80
Unions, 1-1/2"					
150 lb, malleable iron	M5@.360	Ea	18.10	18.90	37.00
300 lb, malleable iron	M5@.400	Ea	25.80	20.90	46.70
Flanges, forged steel, 1-1/2"					
150 lb, threaded flange	M5@.840	Ea	24.50	44.00	68.50
300 lb, threaded flange	M5@1.15	Ea	37.00	60.20	97.20
600 lb, threaded flange	M5@1.26	Ea	79.60	66.00	145.60
Add for galvanized 1-1/2" pipe	—	%	30.0	—	—
Add for galvanized 1-1/2" 150 lb. malleable fittings	—	%	20.0	—	—
Add for galvanized 1-1/2" 300 lb. malleable fittings	—	%	55.0	—	—
Add for galvanized 1-1/2" pipe assembly, Schedule 40	—	%	30.0	—	—
2" carbon steel (A53) threaded pipe and fittings					
Pipe, no fittings or supports included, 2", threaded					
Schedule 40 to 10' high	M5@.120	LF	6.97	6.28	13.25
Schedule 40 over 10' to 20'	M5@.140	LF	6.97	7.33	14.30
Schedule 80 to 10' high	M5@.130	LF	10.90	6.81	17.71
Schedule 80 over 10' to 20'	M5@.150	LF	10.90	7.86	18.76
Pipe assembly, Schedule 40, fittings, hangers and supports	M5@.250	LF	8.76	13.10	21.86
Add for seamless pipe (A106)	—	%	40.0	—	—

22 Plumbing

	Craft@Hrs	Unit	Material	Labor	Total
90-degree ells, 2" threaded					
150 lb, malleable iron	M5@.380	Ea	10.80	19.90	30.70
300 lb, malleable iron	M5@.418	Ea	26.80	21.90	48.70
45-degree ells, 2" threaded					
150 lb, malleable iron	M5@.380	Ea	10.90	19.90	30.80
300 lb, malleable iron	M5@.418	Ea	35.10	21.90	57.00
Tees, 2" threaded					
150 lb, malleable iron	M5@.490	Ea	14.30	25.70	40.00
300 lb, malleable iron	M5@.539	Ea	31.70	28.20	59.90
150 lb, reducing, malleable iron	M5@.460	Ea	17.70	24.10	41.80
300 lb, reducing, malleable iron	M5@.500	Ea	40.60	26.20	66.80
Caps, 2" threaded					
150 lb, malleable iron	M5@.290	Ea	5.80	15.20	21.00
300 lb, malleable iron	M5@.320	Ea	13.90	16.80	30.70
Couplings, 2" threaded					
150 lb, malleable iron	M5@.380	Ea	8.83	19.90	28.73
300 lb, malleable iron	M5@.418	Ea	20.90	21.90	42.80
Flanges, forged steel, 2"					
150 lb, threaded flange	M5@.290	Ea	31.20	15.20	46.40
300 lb, threaded flange	M5@.310	Ea	49.50	16.20	65.70
600 lb, threaded flange	M5@.320	Ea	127.00	16.80	143.80
Unions, 2"					
150 lb, malleable iron	M5@.450	Ea	20.70	23.60	44.30
300 lb, malleable iron	M5@.500	Ea	57.80	26.20	84.00
Add for galvanized 2" pipe, add	—	%	30.0	—	—
Add for galvanized 2" 50 lb. malleable fittings	—	%	20.0	—	—
Add for galvanized 2" 300 lb. malleable fittings	—	%	55.0	—	—
Add for galvanized 2" pipe assembly, Schedule 40	—	%	30.0	—	—
3" carbon steel pipe (A53) and welded fittings					
Pipe, no fittings or supports included, 3", plain end					
Schedule 40 to 10' high	MI@.190	LF	7.62	10.60	18.22
Schedule 40 over 10' to 20' high	MI@.230	LF	7.62	12.90	20.52
Schedule 80 to 10' high	MI@.280	LF	16.30	15.70	32.00
Schedule 80 over 10' to 20' high	MI@.335	LF	16.30	18.70	35.00
Pipe assembly, Schedule 40, fittings, hangers and supports	MI@.380	LF	11.10	21.30	32.40
Add for seamless pipe (A106)	—	%	40.0	—	—
Add for galvanized pipe assembly, Schedule 40	—	%	30.0	—	—
Butt welded joints, 3" pipe					
Schedule 40 pipe	MI@.930	Ea	—	52.00	52.00
Schedule 80 pipe	MI@1.11	Ea	—	62.10	62.10
90-degree ells, 3"					
Schedule 40 carbon steel, butt weld, long turn	MI@1.33	Ea	17.50	74.40	91.90
Schedule 80 carbon steel, butt weld, long turn	MI@1.77	Ea	24.80	99.00	123.80
45-degree ells, 3"					
Schedule 40, carbon steel, butt weld	MI@1.33	Ea	12.40	74.40	86.80
Schedule 80, carbon steel, butt weld	MI@1.77	Ea	17.50	99.00	116.50
Tees, 3"					
Schedule 40, carbon steel, butt weld	MI@2.00	Ea	35.30	112.00	147.30
Schedule 80, carbon steel, butt weld	MI@2.66	Ea	71.10	149.00	220.10
Reducing, Schedule 40, carbon steel, butt weld	MI@1.89	Ea	45.90	106.00	151.90

22 Plumbing

	Craft@Hrs	Unit	Material	Labor	Total
Caps, 3"					
Schedule 40, carbon steel, butt weld	MI@.930	Ea	21.30	52.00	73.30
Schedule 80, carbon steel, butt weld	MI@1.11	Ea	15.10	62.10	77.20
Reducing couplings					
Schedule 40, carbon steel, butt weld	MI@1.20	Ea	24.90	67.10	92.00
Weld-o-lets, 3"					
Schedule 40, carbon steel	MI@2.00	Ea	76.00	112.00	188.00
Welded pipe flanges, forged steel, 3" butt weld					
150 lb, slip-on flange	MI@.730	Ea	33.40	40.80	74.20
300 lb, slip-on flange	MI@.980	Ea	45.70	54.80	100.50
600 lb, slip-on flange	MI@1.03	Ea	91.30	57.60	148.90
150 lb, weld neck flange	MI@.730	Ea	41.60	40.80	82.40
300 lb, weld neck flange	MI@.980	Ea	51.80	54.80	106.60
600 lb, weld neck flange	MI@1.03	Ea	88.20	57.60	145.80
150 lb, threaded flange	MI@.460	Ea	60.40	25.70	86.10
300 lb, threaded flange	MI@.500	Ea	73.60	28.00	101.60
600 lb, threaded flange	MI@.510	Ea	121.00	28.50	149.50
Flange bolt & gasket kits, 3"					
Full face, red rubber gasket, 150 lb	MI@.750	Ea	10.20	42.00	52.20
Full face, red rubber gasket, 300 lb	MI@1.00	Ea	12.30	55.90	68.20
4" carbon steel pipe (A53) and welded fittings					
Pipe, no fittings or supports included, 4", plain end					
Schedule 40 to 10' high	MI@.260	LF	9.02	14.50	23.52
Schedule 40 over 10' to 20' high	MI@.360	LF	9.02	20.10	29.12
Schedule 80 to 10' high	MI@.340	LF	19.80	19.00	38.80
Schedule 80 over 10' to 20' high	MI@.400	LF	19.80	22.40	42.20
Pipe assembly, Schedule 40, fittings, hangers and supports	MI@.430	LF	13.90	24.10	38.00
Add for seamless pipe (A106)	—	%	35.0	—	—
Add for galvanized pipe assembly, Schedule 40	—	%	30.0	—	—
Butt welded joints, 4" pipe					
Schedule 40 pipe	MI@1.25	Ea	—	69.90	69.90
Schedule 80 pipe	MI@1.50	Ea	—	83.90	83.90
90-degree ells, 4"					
Schedule 40 carbon steel, butt weld, long turn	MI@1.33	Ea	28.20	74.40	102.60
Schedule 80 carbon steel, butt weld, long turn	MI@2.37	Ea	60.00	133.00	193.00
45-degree ells, 4"					
Schedule 40, carbon steel, butt weld	MI@1.33	Ea	18.80	74.40	93.20
Schedule 80, carbon steel, butt weld	MI@2.37	Ea	26.70	133.00	159.70
Tees, 4"					
Schedule 40, carbon steel, butt weld	MI@2.67	Ea	48.40	149.00	197.40
Schedule 80, carbon steel, butt weld	MI@3.55	Ea	75.50	199.00	274.50
Reducing, Schedule 40 carbon steel, butt weld	MI@2.44	Ea	49.70	136.00	185.70
Caps, 4"					
Schedule 40, carbon steel, butt weld	MI@1.25	Ea	27.90	69.90	97.80
Schedule 80, carbon steel, butt weld	MI@1.50	Ea	20.30	83.90	104.20
Reducing couplings, 4"					
Schedule 40, carbon steel, butt weld	MI@1.60	Ea	24.70	89.50	114.20
Weld-o-lets, 4"					
Schedule 40, carbon steel	MI@2.67	Ea	99.50	149.00	248.50

22 Plumbing

	Craft@Hrs	Unit	Material	Labor	Total
Welded flanges, forged steel, 4"					
150 lb, slip-on flange	Ml@.980	Ea	45.20	54.80	100.00
300 lb, slip-on flange	Ml@1.30	Ea	72.90	72.70	145.60
600 lb, slip-on flange	Ml@1.80	Ea	179.00	101.00	280.00
150 lb, weld neck flange	Ml@.980	Ea	56.10	54.80	110.90
300 lb, weld neck flange	Ml@1.30	Ea	80.60	72.70	153.30
600 lb, weld neck flange	Ml@1.80	Ea	162.00	101.00	263.00
150 lb, threaded flange	Ml@.600	Ea	64.90	33.60	98.50
300 lb, threaded flange	Ml@.640	Ea	82.40	35.80	118.20
600 lb, threaded flange	Ml@.650	Ea	207.00	36.40	243.40
Flange bolt & gasket kits, 4"					
Full face, red rubber gasket, 150 lb	Ml@1.00	Ea	12.30	55.90	68.20
Full face, red rubber gasket, 300 lb	Ml@1.20	Ea	18.10	67.10	85.20
6" carbon steel pipe (A53) and welded fittings					
Pipe, no fittings or supports included, 6", plain end					
Schedule 40 to 10' high	M8@.420	LF	14.30	24.20	38.50
Schedule 40 over 10' to 20'	M8@.500	LF	14.30	28.90	43.20
Schedule 80 to 10' high	M8@.460	LF	27.10	26.60	53.70
Schedule 80 over 10' to 20'	M8@.550	LF	27.10	31.80	58.90
Pipe assembly, Schedule 40, fittings, hangers and supports	M8@.800	LF	24.40	46.20	70.60
Add for seamless pipe (A106)	—	%	40.0	—	—
Add for galvanized pipe assembly, Schedule 40	—	%	30.0	—	—
Butt welded joints, 6" pipe					
Schedule 40 pipe	M8@1.87	Ea	—	108.00	108.00
Schedule 80 pipe	M8@2.24	Ea	—	129.00	129.00
90-degree ells, 6"					
Schedule 40 carbon steel, butt weld, long turn	M8@2.67	Ea	80.70	154.00	234.70
Schedule 80 carbon steel, butt weld, long turn	M8@3.55	Ea	115.00	205.00	320.00
45-degree ells, 6"					
Schedule 40, carbon steel, butt weld	M8@2.67	Ea	48.40	154.00	202.40
Schedule 80, carbon steel, butt weld	M8@3.55	Ea	75.40	205.00	280.40
Tees, 6"					
Schedule 40, carbon steel, butt weld	M8@4.00	Ea	90.30	231.00	321.30
Schedule 80, carbon steel, butt weld	M8@5.32	Ea	122.00	307.00	429.00
Reducing, Schedule 40 carbon steel, butt weld	M8@3.78	Ea	113.00	218.00	331.00
Caps, 6"					
Schedule 40, carbon steel, butt weld	M8@1.87	Ea	32.90	108.00	140.90
Schedule 80, carbon steel, butt weld	M8@2.24	Ea	38.50	129.00	167.50
Reducing couplings, 6"					
Schedule 40, carbon steel, butt weld	M8@2.30	Ea	46.00	133.00	179.00
Weld-o-lets, 6"					
Schedule 40, carbon steel	M8@3.65	Ea	413.00	211.00	624.00
Welded flanges, forged steel, 6"					
150 lb, slip-on flange	M8@1.47	Ea	72.70	84.90	157.60
300 lb, slip-on flange	M8@1.95	Ea	137.00	113.00	250.00
150 lb, weld neck flange	M8@1.47	Ea	95.00	84.90	179.90
300 lb, weld neck flange	M8@1.95	Ea	146.00	113.00	259.00
Flange bolt & gasket kits, 6"					
Full face, red rubber gasket, 150 lb	M8@1.20	Ea	21.20	69.30	90.50
Full face, red rubber gasket, 300 lb	M8@1.65	Ea	34.00	95.30	129.30

22 Plumbing

	Craft@Hrs	Unit	Material	Labor	Total
8" carbon steel pipe (A53) and welded fittings					
Pipe, no fittings or supports included, 8" plain end					
Schedule 40 to 10' high	M8@.510	LF	31.00	29.40	60.40
Schedule 40 over 10' to 20'	M8@.600	LF	31.00	34.60	65.60
Schedule 80 to 10' high	M8@.560	LF	60.20	32.30	92.50
Schedule 80 over 10' to 20' high	M8@.670	LF	60.20	38.70	98.90
Add for seamless pipe (A106)	—	%	40.0	—	—
Butt welded joints, 8" pipe					
Schedule 40 pipe	M8@2.24	Ea	—	129.00	129.00
Schedule 80 pipe	M8@2.68	Ea	—	155.00	155.00
90-degree ells, 8"					
Schedule 40 carbon steel, butt weld, long turn	M8@3.20	Ea	161.00	185.00	346.00
Schedule 80 carbon steel, butt weld, long turn	M8@4.26	Ea	184.00	246.00	430.00
45-degree ells, 8"					
Schedule 40, carbon steel, butt weld	M8@3.20	Ea	99.60	185.00	284.60
Schedule 80, carbon steel, butt weld	M8@4.26	Ea	106.00	246.00	352.00
Tees, 8"					
Schedule 40, carbon steel, butt weld	M8@4.80	Ea	182.00	277.00	459.00
Schedule 80, carbon steel, butt weld	M8@6.38	Ea	214.00	368.00	582.00
Reducing, Schedule 40, carbon steel, butt weld	M8@4.40	Ea	243.00	254.00	497.00
Caps, 8"					
Schedule 40, carbon steel, butt weld	M8@2.24	Ea	51.20	129.00	180.20
Schedule 80, carbon steel, butt weld	M8@2.68	Ea	51.50	155.00	206.50
Reducing couplings, 8"					
Schedule 40, carbon steel, butt weld	M8@2.88	Ea	106.00	166.00	272.00
Weld-o-lets, 8"					
Schedule 40, carbon steel	M8@4.76	Ea	678.00	275.00	953.00
Welded flanges, forged steel, 8"					
150 lb, slip-on flange	M8@1.77	Ea	98.60	102.00	200.60
300 lb, slip-on flange	M8@2.35	Ea	187.00	136.00	323.00
150 lb, weld neck flange	M8@1.77	Ea	137.00	102.00	239.00
300 lb, weld neck flange	M8@2.35	Ea	200.00	136.00	336.00
Flange bolt & gasket kits, 8"					
Full face, red rubber gasket, 150 lb	M8@1.40	Ea	20.30	80.80	101.10
Full face, red rubber gasket, 300 lb	M8@1.85	Ea	31.80	107.00	138.80
10" carbon steel pipe (A53) and welded fittings					
Pipe, no fittings or supports included, 10", plain end					
Schedule 40 to 20' high	M8@.720	LF	44.40	41.60	86.00
Schedule 80 to 20' high	M8@.830	LF	104.00	47.90	151.90
Add for seamless pipe (A106)	—	%	40.0	—	—
Butt welded joints, 10" pipe					
Schedule 40 pipe	M8@2.70	Ea	—	156.00	156.00
Schedule 80 pipe	M8@3.22	Ea	—	186.00	186.00
90-degree ells, 10"					
Schedule 40 carbon steel, butt weld, long turn	M8@4.00	Ea	287.00	231.00	518.00
Schedule 80 carbon steel, butt weld, long turn	M8@5.75	Ea	336.00	332.00	668.00
45-degree ells, 10"					
Schedule 40, carbon steel, butt weld	M8@4.00	Ea	153.00	231.00	384.00
Schedule 80, carbon steel, butt weld	M8@5.75	Ea	170.00	332.00	502.00

22 Plumbing

	Craft@Hrs	Unit	Material	Labor	Total
Tees, 10"					
Schedule 40, carbon steel, butt weld	M8@6.00	Ea	410.00	346.00	756.00
Schedule 80, carbon steel, butt weld	M8@8.61	Ea	345.00	497.00	842.00
Reducing, Schedule 40, carbon steel, butt weld	M8@5.60	Ea	410.00	323.00	733.00
Caps, 10"					
Schedule 40, carbon steel, butt weld	M8@2.80	Ea	86.00	162.00	248.00
Schedule 80, carbon steel, butt weld	M8@3.62	Ea	76.40	209.00	285.40
Reducing couplings, 10"					
Schedule 40, carbon steel, butt weld	M8@3.60	Ea	94.50	208.00	302.50
Weld-o-lets, 10"					
Schedule 40, carbon steel	M8@6.35	Ea	930.00	367.00	1,297.00
Welded pipe flanges, forged steel, 10"					
150 lb, slip-on flange	M8@2.20	Ea	163.00	127.00	290.00
150 lb, weld neck flange	M8@2.20	Ea	223.00	127.00	350.00
300 lb, weld neck flange	M8@2.90	Ea	453.00	167.00	620.00
Flange bolt & gasket kits, 10"					
Full face, red rubber gasket, 150 lb	M8@1.80	Ea	40.10	104.00	144.10
Full face, red rubber gasket, 300 lb	M8@2.20	Ea	50.70	127.00	177.70
12" carbon steel pipe (A53) and welded fittings					
Pipe, no fittings or supports included, 12", plain end					
Schedule 40 to 20' high	M8@.910	LF	53.60	52.50	106.10
Schedule 80 to 20' high	M8@1.05	LF	120.00	60.60	180.60
Add for seamless pipe (A106)	—	%	40.0	—	—
Butt welded joints, 12" pipe					
Schedule 40 pipe	M8@3.25	Ea	—	188.00	188.00
Schedule 80 pipe	M8@3.88	Ea	—	224.00	224.00
90-degree ells, 12"					
Schedule 40 carbon steel, butt weld, long turn	M8@4.80	Ea	426.00	277.00	703.00
Schedule 80 carbon steel, butt weld, long turn	M8@7.76	Ea	470.00	448.00	918.00
45-degree ells, 12"					
Schedule 40, carbon steel, butt weld	M8@4.80	Ea	222.00	277.00	499.00
Schedule 80, carbon steel, butt weld	M8@7.76	Ea	255.00	448.00	703.00
Tees, 12"					
Schedule 40, carbon steel, butt weld	M8@7.20	Ea	471.00	416.00	887.00
Schedule 80, carbon steel, butt weld	M8@11.6	Ea	500.00	670.00	1,170.00
Reducing, Schedule 40, carbon steel, butt weld	M8@6.80	Ea	610.00	393.00	1,003.00
Caps, 12"					
Schedule 40, carbon steel, butt weld	M8@3.36	Ea	108.00	194.00	302.00
Schedule 80, carbon steel, butt weld	M8@4.88	Ea	101.00	282.00	383.00
Reducing couplings, 12"					
Schedule 40, carbon steel, butt weld	M8@4.30	Ea	277.00	248.00	525.00
Weld-o-lets, 12"					
Schedule 40, carbon steel	M8@8.48	Ea	1,140.00	490.00	1,630.00
Welded flanges, forged steel, 12"					
150 lb, slip-on flange	M8@2.64	Ea	330.00	152.00	482.00
300 lb, slip-on flange	M8@3.50	Ea	556.00	202.00	758.00
150 lb, weld neck flange	M8@2.64	Ea	422.00	152.00	574.00
300 lb, weld neck flange	M8@3.50	Ea	740.00	202.00	942.00
Flange bolt & gasket kits, 12"					
Full face, red rubber gasket, 150 lb	M8@2.20	Ea	52.70	127.00	179.70
Full face, red rubber gasket, 300 lb	M8@2.60	Ea	68.10	150.00	218.10

22 Plumbing

Craft@Hrs	Unit	Material	Labor	Total
-----------	------	----------	-------	-------

Copper Pressure Pipe and Soldered Copper Fittings Note that copper pipe and fitting prices can change very quickly as the price of copper changes. No hangers included. See pipe hangers in the sections that follow. Labor cost assumes pipe is installed either horizontally or vertically in a building and up to 10' above floor level. Add 25% to the labor cost for heights over 10' above floor level. For more detailed coverage of copper pressure pipe, see *National Plumbing & HVAC Estimator*, <https://craftsman-book.com/national-estimator-cloud>.

Type M hard copper pipe Used for water supply pressure piping above ground inside residential buildings. Smaller quantities purchased from building material retailers may cost more. Larger quantities purchased from specialty suppliers will cost less. Add the cost of soldered wrought copper fittings and supports in the sections that follow.

1/2" pipe	P6@.032	LF	1.41	1.69	3.10
3/4" pipe	P6@.035	LF	2.31	1.85	4.16
1" pipe	P6@.038	LF	4.02	2.01	6.03
1-1/4" pipe	P6@.042	LF	6.00	2.22	8.22
1-1/2" pipe	P6@.046	LF	7.77	2.43	10.20
2" pipe	P6@.053	LF	12.20	2.80	15.00
2-1/2" pipe	P6@.060	LF	17.70	3.17	20.87
3" pipe	P6@.066	LF	22.50	3.49	25.99
4" pipe	P6@.080	LF	39.00	4.23	43.23

Type L hard copper pipe is commonly used for water supply pressure piping in commercial buildings, either above or below ground. Larger quantities will cost less. Smaller quantities purchased from building material retailers will cost more. Add the cost of soldered wrought copper fittings and supports in the sections that follow.

1/2" pipe	P6@.032	LF	2.06	1.69	3.75
3/4" pipe	P6@.035	LF	3.25	1.85	5.10
1" pipe	P6@.038	LF	5.03	2.01	7.04
1-1/4" pipe	P6@.042	LF	7.20	2.22	9.42
1-1/2" pipe	P6@.046	LF	9.95	2.43	12.38
2" pipe	P6@.053	LF	13.20	2.80	16.00
2-1/2" pipe	P6@.060	LF	25.20	3.17	28.37
3" pipe	P6@.066	LF	34.10	3.49	37.59
4" pipe	P6@.080	LF	54.10	4.23	58.33

Type L soft copper tube Type L tube is commonly used for water supply pressure piping in commercial buildings, either above or below ground. Commercial quantities will cost less. Smaller quantities purchased from building material retailers will cost more. Add the cost of copper fittings and supports in the sections that follow.

1/4", 60' coil	P6@.020	LF	1.62	1.06	2.68
3/8", 10' coil	P6@.020	LF	2.11	1.06	3.17
3/8", 20' coil	P6@.020	LF	2.40	1.06	3.46
3/8", 60' coil	P6@.020	LF	2.60	1.06	3.66
1/2", 10' coil	P6@.025	LF	2.94	1.32	4.26
1/2", 20' coil	P6@.025	LF	2.84	1.32	4.16
1/2", 60' coil	P6@.025	LF	3.39	1.32	4.71
1/2", 100' coil	P6@.025	LF	2.68	1.32	4.00
5/8", 20' coil	P6@.030	LF	2.87	1.59	4.46
5/8", 50' coil	P6@.030	LF	3.96	1.59	5.55
3/4", 60' coil	P6@.030	LF	5.27	1.59	6.86
3/4", 100' coil	P6@.030	LF	4.92	1.59	6.51
1", 100' coil	P6@.035	LF	6.74	1.85	8.59
1-1/4", 60' coil	P6@.042	LF	9.08	2.22	11.30
1-1/2", 60' coil	P6@.046	LF	10.80	2.43	13.23

Type K hard copper pipe Installed in an open trench to 5' deep. No excavation or backfill included. Type K is acceptable for applications above and below ground, inside and outside of buildings. Use corporation (compression) fittings rather than soldered joints in underground applications. Based on commercial quantity purchases. Smaller quantities will cost up to 35% more. Add the cost of fittings and hangers when required.

1/2" pipe	P6@.032	LF	2.46	1.69	4.15
3/4" pipe	P6@.035	LF	4.10	1.85	5.95

22 Plumbing

Craft@Hrs Unit Material Labor Total

Type K soft copper tube Type K is acceptable for applications above and below ground, inside and outside of buildings. Use corporation (compression) fittings rather than soldered joints in underground applications.

Commercial quantities will cost less. Smaller quantities purchased from building material retailers will cost more.

Add the cost of copper fittings and supports in the sections that follow.

1/2", 60' coil	P6@.025	LF	4.09	1.32	5.41
3/4", 60' coil	P6@.030	LF	6.79	1.59	8.38
3/4", 100' coil	P6@.030	LF	5.05	1.59	6.64
1", 100' coil	P6@.035	LF	11.40	1.85	13.25

Soft copper refrigeration tube Commercial quantities will cost less. Smaller quantities purchased from building material retailers will cost more.

Add the cost of copper fittings and supports in the sections that follow.

1/4", 10' coil	P6@.020	LF	1.14	1.06	2.20
1/4", 20' coil	P6@.020	LF	1.04	1.06	2.10
1/4", 50' coil	P6@.020	LF	1.03	1.06	2.09
3/8", 20' coil	P6@.020	LF	1.61	1.06	2.67
3/8", 50' coil	P6@.020	LF	1.29	1.06	2.35
1/2", 50' coil	P6@.025	LF	1.69	1.32	3.01
5/8", 50' coil	P6@.030	LF	2.17	1.59	3.76

Copper pressure fittings Soldered wrought copper fittings. Solder is 95% tin and 5% antimony (lead free).

Installed either horizontally or vertically in a building up to 10' above floor level.

1/2" copper pressure fittings

1/2" 90-degree ell	P6@.107	Ea	.39	5.66	6.05
1/2" 45-degree ell	P6@.107	Ea	1.22	5.66	6.88
1/2" tee	P6@.129	Ea	.72	6.83	7.55
1/2" x 1/2" x 3/8" reducing tee	P6@.121	Ea	9.30	6.40	15.70
1/2" cap	P6@.069	Ea	.60	3.65	4.25
1/2" coupling	P6@.107	Ea	.47	5.66	6.13
1/2" copper x male pipe thread adapter	P6@.086	Ea	1.38	4.55	5.93

3/4" copper pressure fittings

3/4" 90-degree ell	P6@.150	Ea	1.06	7.94	9.00
3/4" 45-degree ell	P6@.150	Ea	2.54	7.94	10.48
3/4" tee	P6@.181	Ea	2.84	9.58	12.42
3/4" x 3/4" x 1/2" reducing tee	P6@.170	Ea	3.92	8.99	12.91
3/4" cap	P6@.096	Ea	.97	5.08	6.05
3/4" coupling	P6@.150	Ea	.88	7.94	8.82
3/4" copper x male pipe thread adapter	P6@.105	Ea	5.48	5.56	11.04

1" copper pressure fittings

1" 90-degree ell	P6@.193	Ea	1.81	10.20	12.01
1" 45-degree ell	P6@.193	Ea	6.31	10.20	16.51
1" tee	P6@.233	Ea	8.73	12.30	21.03
1" x 1" x 3/4" reducing tee	P6@.219	Ea	10.90	11.60	22.50
1" cap	P6@.124	Ea	2.61	6.56	9.17
1" coupling	P6@.193	Ea	2.87	10.20	13.07
1" copper x male pipe thread adapter	P6@.134	Ea	11.70	7.09	18.79

1-1/4" copper pressure fittings

1-1/4" 90-degree ell	P6@.236	Ea	6.82	12.50	19.32
1-1/4" 45-degree ell	P6@.236	Ea	9.38	12.50	21.88
1-1/4" tee	P6@.285	Ea	13.20	15.10	28.30
1-1/4" x 1-1/4" x 1" reducing tee	P6@.268	Ea	18.80	14.20	33.00
1-1/4" cap	P6@.151	Ea	3.94	7.99	11.93
1-1/4" coupling	P6@.236	Ea	3.50	12.50	16.00
1-1/4" copper x male pipe thread adapter	P6@.163	Ea	7.17	8.62	15.79

22 Plumbing

	Craft@Hrs	Unit	Material	Labor	Total
1-1/2" copper pressure fittings					
1-1/2" 90-degree ell	P6@.278	Ea	11.00	14.70	25.70
1-1/2" 45-degree ell	P6@.278	Ea	10.60	14.70	25.30
1-1/2" tee	P6@.337	Ea	19.90	17.80	37.70
1-1/2" x 1-1/2" x 1-1/4" reducing tee	P6@.302	Ea	17.10	16.00	33.10
1-1/2" cap	P6@.178	Ea	5.64	9.42	15.06
1-1/2" coupling	P6@.278	Ea	7.10	14.70	21.80
1-1/2" copper x male pipe thread adapter	P6@.194	Ea	13.30	10.30	23.60
2" copper pressure fittings					
2" 90-degree ell	P6@.371	Ea	21.00	19.60	40.60
2" 45-degree ell	P6@.371	Ea	19.70	19.60	39.30
2" tee	P6@.449	Ea	21.60	23.80	45.40
2" x 2" x 1-1/2" reducing tee	P6@.422	Ea	35.00	22.30	57.30
2" cap	P6@.238	Ea	9.70	12.60	22.30
2" coupling	P6@.371	Ea	8.11	19.60	27.71
2" copper x male pipe thread adapter	P6@.259	Ea	19.70	13.70	33.40
2-1/2" copper pressure fittings					
2-1/2" 90-degree ell	P6@.457	Ea	28.40	24.20	52.60
2-1/2" 45-degree ell	P6@.457	Ea	46.50	24.20	70.70
2-1/2" tee	P6@.552	Ea	69.80	29.20	99.00
2-1/2" x 2 1/2" x 2" reducing tee	P6@.519	Ea	90.30	27.50	117.80
2-1/2" cap	P6@.292	Ea	36.60	15.40	52.00
2-1/2" coupling	P6@.457	Ea	15.00	24.20	39.20
2-1/2" copper x male pipe thread adapter	P6@.319	Ea	69.90	16.90	86.80
3" copper pressure fittings					
3" 90-degree ell	P6@.543	Ea	63.20	28.70	91.90
3" 45-degree ell	P6@.543	Ea	67.30	28.70	96.00
3" tee	P6@.656	Ea	101.00	34.70	135.70
3" x 3" x 2" reducing tee	P6@.585	Ea	119.00	31.00	150.00
3" cap	P6@.347	Ea	48.80	18.40	67.20
3" coupling	P6@.543	Ea	31.30	28.70	60.00
3" copper x male pipe thread adapter	P6@.375	Ea	70.30	19.80	90.10
4" copper pressure fittings					
4" 90-degree ell	P6@.714	Ea	155.00	37.80	192.80
4" 45-degree ell	P6@.714	Ea	137.00	37.80	174.80
4" tee	P6@.863	Ea	250.00	45.70	295.70
4" x 4" x 3" reducing tee	P6@.811	Ea	255.00	42.90	297.90
4" cap	P6@.457	Ea	91.60	24.20	115.80
4" coupling	P6@.714	Ea	60.90	37.80	98.70
4" copper x male pipe thread adapter	P6@.485	Ea	99.10	25.70	124.80

Flexible PVC-Jacketed Copper Tubing For fuel oil, gas and propane transfer lines. Flame retardant and dielectric. Fungus, acid and moisture corrosion resistant. Acceptable for direct burial underground or under concrete. Installed in an open trench.

3/8" OD	PM@.010	LF	1.79	.44	2.23
1/2" OD	PM@.010	LF	2.16	.44	2.60
5/8" OD	PM@.010	LF	3.00	.44	3.44

Shrinkage kit for flexible PVC-jacketed copper tubing. Add for shrinkage tubing kit to allow for the coupling of sections with standard flare fittings. Per joint.

Kit for 3/8" flare fittings	—	Ea	14.60	—	14.60
Kit for 1/2" flare fittings	—	Ea	15.60	—	15.60
Kit for 5/8" flare fittings	—	Ea	17.90	—	17.90

22 Plumbing

	Craft@Hrs	Unit	Material	Labor	Total
Schedule 40 PVC Pressure Pipe and Socket-weld Fittings Installed in a building vertically or horizontally up to 10' above floor level.					
1/2" Schedule 40 PVC pressure pipe and fittings					
1/2" pipe	P6@.020	LF	.43	1.06	1.49
1/2" 90-degree ell	P6@.100	Ea	.50	5.29	5.79
1/2" tee	P6@.130	Ea	.59	6.88	7.47
3/4" Schedule 40 PVC pressure pipe and fittings					
3/4" pipe	P6@.025	LF	.51	1.32	1.83
3/4" 90-degree ell	P6@.115	Ea	.65	6.08	6.73
3/4" tee	P6@.140	Ea	.77	7.41	8.18
1" Schedule 40 PVC pressure pipe and fittings					
1" pipe	P6@.030	LF	.72	1.59	2.31
1" 90-degree ell	P6@.120	Ea	1.26	6.35	7.61
1" tee	P6@.170	Ea	1.77	8.99	10.76
1-1/4" Schedule 40 PVC pressure pipe and fittings					
1-1/4" pipe	P6@.035	LF	3.44	1.85	5.29
1-1/4" 90-degree ell	P6@.160	Ea	1.88	8.47	10.35
1-1/4" tee	P6@.220	Ea	2.64	11.60	14.24
1-1/2" Schedule 40 PVC pressure pipe and fittings					
1-1/2" pipe	P6@.040	LF	1.94	2.12	4.06
1-1/2" 90-degree ell	P6@.180	Ea	2.53	9.52	12.05
1-1/2" tee	P6@.250	Ea	3.08	13.20	16.28
2" Schedule 40 PVC pressure pipe and fittings					
2" pipe	P6@.046	LF	2.54	2.43	4.97
2" 90-degree ell	P6@.200	Ea	3.18	10.60	13.78
2" tee	P6@.280	Ea	3.76	14.80	18.56
2-1/2" Schedule 40 PVC pressure pipe and fittings					
2-1/2" pipe	P6@.053	LF	2.45	2.80	5.25
2-1/2" 90-degree ell	P6@.250	Ea	5.47	13.20	18.67
2-1/2" tee	P6@.350	Ea	6.82	18.50	25.32
3" Schedule 40 PVC pressure pipe and fittings					
3" pipe	P6@.055	LF	4.75	2.91	7.66
3" 90-degree ell	P6@.300	Ea	6.20	15.90	22.10
3" tee	P6@.420	Ea	8.94	22.20	31.14
4" Schedule 40 PVC pressure pipe and fittings					
4" pipe	P6@.070	LF	6.26	3.70	9.96
4" 90-degree ell	P6@.500	Ea	11.00	26.50	37.50
4" tee	P6@.560	Ea	16.20	29.60	45.80
Schedule 80 PVC Pressure Pipe and Socket-Weld Fittings Installed in a building vertically or horizontally up to 10' above floor level.					
1/2" Schedule 80 PVC pressure pipe and fittings					
1/2" pipe	P6@.021	LF	.88	1.11	1.99
1/2" 90-degree ell	P6@.105	Ea	1.10	5.56	6.66
1/2" tee	P6@.135	Ea	3.12	7.14	10.26
3/4" Schedule 80 PVC pressure pipe and fittings					
3/4" pipe	P6@.026	LF	1.57	1.38	2.95
3/4" 90-degree ell	P6@.120	Ea	1.47	6.35	7.82
3/4" tee	P6@.145	Ea	3.28	7.67	10.95
1" Schedule 80 PVC pressure pipe and fittings					
1" pipe	P6@.032	LF	2.05	1.69	3.74
1" 90-degree ell	P6@.125	Ea	2.28	6.61	8.89
1" tee	P6@.180	Ea	4.18	9.52	13.70

22 Plumbing

	Craft@Hrs	Unit	Material	Labor	Total
1-1/4" Schedule 80 PVC pressure pipe and fittings					
1-1/4" pipe	P6@.037	LF	2.72	1.96	4.68
1-1/4" 90-degree ell	P6@.170	Ea	3.07	8.99	12.06
1-1/4" tee	P6@.230	Ea	11.40	12.20	23.60
1-1/2" Schedule 80 PVC pressure pipe and fittings					
1-1/2" pipe	P6@.042	LF	2.92	2.22	5.14
1-1/2" 90-degree ell	P6@.190	Ea	3.23	10.10	13.33
1-1/2" tee	P6@.265	Ea	11.40	14.00	25.40
2" Schedule 80 PVC pressure pipe and fittings					
2" pipe	P6@.047	LF	3.90	2.49	6.39
2" 90-degree ell	P6@.210	Ea	3.91	11.10	15.01
2" tee	P6@.295	Ea	14.20	15.60	29.80
2-1/2" Schedule 80 PVC pressure pipe and fittings					
2-1/2" pipe	P6@.052	LF	6.10	2.75	8.85
2-1/2" 90-degree ell	P6@.262	Ea	10.00	13.90	23.90
2-1/2" tee	P6@.368	Ea	16.80	19.50	36.30
3" Schedule 80 PVC pressure pipe and fittings					
3" pipe	P6@.057	LF	7.35	3.02	10.37
3" 90-degree ell	P6@.315	Ea	10.50	16.70	27.20
3" tee	P6@.440	Ea	19.50	23.30	42.80
4" Schedule 80 PVC pressure pipe and fittings					
4" pipe	P6@.074	LF	10.30	3.92	14.22
4" 90-degree ell	P6@.520	Ea	16.10	27.50	43.60
4" tee	P6@.585	Ea	22.60	31.00	53.60

CPVC Chlorinated Pressure Pipe and Socket-Weld Fittings Installed in a building vertically or horizontally up to 10' above floor level. CPVC pipe is the plastic alternative to traditional copper pipe. For hot and cold water distribution to 210 degrees F. Tan in color. Complies with ASTM D 2846 and has the same outside diameter as copper tubing. SDR 11 pressure pipe has the same pressure rating for all pipe diameters. FlowGuard Gold® pipe has a gold stripe.

1/2" CPVC chlorinated pressure pipe and fittings					
#4120 SDR 11 CPVC pipe	P6@.020	LF	.34	1.06	1.40
FlowGuard Gold pipe	P6@.020	LF	.47	1.06	1.53
90-degree elbow	P6@.100	Ea	.38	5.29	5.67
90-degree drop-ear elbow	P6@.100	Ea	1.28	5.29	6.57
FlowGuard drop-ear reducing elbow	P6@.100	Ea	.93	5.29	6.22
45-degree elbow	P6@.100	Ea	.45	5.29	5.74
Coupling	P6@.100	Ea	.35	5.29	5.64
90-degree street elbow	P6@.100	Ea	.42	5.29	5.71
Tee, 1/2" x 1/2" x 1/2"	P6@.130	Ea	.42	6.88	7.30
Tee, 1/2" x 3/4" x 3/4"	P6@.150	Ea	.79	7.94	8.73
Union	P6@.200	Ea	4.39	10.60	14.99
Compression coupling	P6@.200	Ea	3.44	10.60	14.04
Bushing, 1/2" x 1/8" bushing	P6@.080	Ea	3.61	4.23	7.84
Cap	P6@.060	Ea	.38	3.17	3.55
3/4" CPVC chlorinated pressure pipe and fittings					
#4120 SDR 11 CPVC pipe	P6@.025	LF	.59	1.32	1.91
FlowGuard Gold pipe	P6@.025	LF	.72	1.32	2.04
90-degree elbow	P6@.115	Ea	.58	6.08	6.66
45-degree elbow	P6@.115	Ea	.63	6.08	6.71
Coupling	P6@.115	Ea	.42	6.08	6.50
90-degree street elbow	P6@.115	Ea	.68	6.08	6.76
90-degree reducing elbow, 3/4" x 1/2"	P6@.115	Ea	.68	6.08	6.76

22 Plumbing

	Craft@Hrs	Unit	Material	Labor	Total
Tee, 3/4" x 3/4" x 3/4"	P6@.140	Ea	.83	7.41	8.24
Tee, 3/4" x 1/2" x 1/2"	P6@.140	Ea	.99	7.41	8.40
Tee, 3/4" x 1/2" x 3/4"	P6@.150	Ea	.85	7.94	8.79
Tee, 3/4" x 3/4" x 1/2"	P6@.150	Ea	.97	7.94	8.91
Tee, 3/4" x 1/2" x 1/2"	P6@.150	Ea	.99	7.94	8.93
Cap	P6@.070	Ea	.44	3.70	4.14
Bushing, 1" x 1/2"	P6@.080	Ea	2.50	4.23	6.73
Bushing, 3/4" x 1/2"	P6@.080	Ea	.48	4.23	4.71
Union	P6@.250	Ea	7.40	13.20	20.60
Reducing coupling, 3/4" x 1/2"	P6@.115	Ea	.46	6.08	6.54
Compression coupling	P6@.200	Ea	6.23	10.60	16.83
1" CPVC chlorinated pressure pipe and fittings					
FlowGuard Gold pipe	P6@.030	Ea	1.68	1.59	3.27
45-degree elbow	P6@.120	Ea	2.70	6.35	9.05
Coupling	P6@.120	Ea	1.85	6.35	8.20
Tee, 1" x 1" x 1"	P6@.170	Ea	3.73	8.99	12.72
Tee, 1" x 1" x 3/4"	P6@.170	Ea	12.50	8.99	21.49
Cap	P6@.070	Ea	2.02	3.70	5.72
Bushing, 1" x 3/4"	P6@.080	Ea	2.45	4.23	6.68
CPVC and brass transition fittings. FIPT means female iron pipe thread. MIPT means male iron pipe thread.					
1/2" union, slip x FIPT	P6@.150	Ea	12.00	7.94	19.94
1/2" drop ear 90-degree elbow, slip x FIPT	P6@.090	Ea	7.18	4.76	11.94
1/2" union, slip x MIPT	P6@.250	Ea	5.43	13.20	18.63
1/2" x 3/4" union, slip x MIPT	P6@.250	Ea	7.21	13.20	20.41
3/4" union, slip x FIPT	P6@.170	Ea	21.00	8.99	29.99
3/4" union, slip x MIPT	P6@.250	Ea	10.50	13.20	23.70
CPVC-to-copper-pipe transition fittings. One slip joint and one threaded joint. FIPT means female iron pipe thread. MIPT means male iron pipe thread.					
1/2" slip x FIPT	P6@.080	Ea	7.20	4.23	11.43
3/4" slip x FIPT	P6@.085	Ea	9.80	4.50	14.30
1/2" slip x MIPT	P6@.080	Ea	6.44	4.23	10.67
3/4" slip x MIPT	P6@.085	Ea	8.26	4.50	12.76
CPVC adapter fittings. One slip joint and one threaded joint. Joins CVPV pipe to threaded fittings or valves. FIPT means female iron pipe thread. MIPT means male iron pipe thread.					
1/2" slip x FIPT	P6@.090	Ea	1.28	4.76	6.04
1/2" slip x MIPT	P6@.090	Ea	.52	4.76	5.28
1/2" SPIG x compression	P6@.090	Ea	.96	4.76	5.72
3/4" slip x MIPT	P6@.100	Ea	.56	5.29	5.85
3/4" slip x FIPT	P6@.100	Ea	1.27	5.29	6.56
1" slip x FIPT	P6@.120	Ea	1.62	6.35	7.97
1" slip x MIPT	P6@.120	Ea	2.51	6.35	8.86
CPVC snap-on tubing strap. Secures CPVC pipe in a horizontal or vertical position. Polypropylene.					
1/2" pipe	P6@.110	Ea	.12	5.82	5.94
3/4" pipe	P6@.115	Ea	.17	6.08	6.25
Schedule 80 CPVC Chlorinated Pressure Pipe and Socket-weld Fittings Installed in a building vertically or horizontally up to 10' above floor level. Typical use is in fire protection systems.					
3/4" Schedule 80 CPVC chlorinated pressure pipe and fittings					
3/4" pipe	SP@.055	LF	1.25	3.60	4.85
3/4" 90-degree ell	SP@.100	Ea	2.32	6.55	8.87
3/4" tee	SP@.150	Ea	4.32	9.82	14.14

22 Plumbing

	Craft@Hrs	Unit	Material	Labor	Total
1" Schedule 80 CPVC chlorinated pressure pipe and fittings					
1" pipe	SP@.055	LF	1.22	3.60	4.82
1" 90-degree ell	SP@.120	Ea	3.67	7.86	11.53
1" tee	SP@.170	Ea	5.30	11.10	16.40
1-1/4" Schedule 80 CPVC chlorinated pressure pipe and fittings					
1-1/4" pipe	SP@.065	LF	1.92	4.26	6.18
1-1/4" 90-degree ell	SP@.170	Ea	8.05	11.10	19.15
1-1/4" tee	SP@.230	Ea	12.50	15.10	27.60
1-1/2" Schedule 80 CPVC chlorinated pressure pipe and fittings					
1-1/2" pipe	SP@.075	LF	2.01	4.91	6.92
1-1/2" 90-degree ell	SP@.180	Ea	8.85	11.80	20.65
1-1/2" tee	SP@.250	Ea	12.80	16.40	29.20
2" Schedule 80 CPVC chlorinated pressure pipe and fittings					
2" pipe	SP@.085	LF	2.78	5.56	8.34
2" 90-degree ell	SP@.200	Ea	10.70	13.10	23.80
2" tee	SP@.280	Ea	14.10	18.30	32.40
PEX Tube and Fittings Cross-linked polyethylene tube installed in a building vertically or horizontally up to 10' above floor level. Using crimped connections. By copper tube size. Based on 100' rolls of color coded (red, blue or white) tube. For domestic water systems and in-floor hydronics heating systems. Oxygen-barrier PEX is required in heating systems.					
3/8" PEX tube					
3/8" AQUAPEX	P6@.019	LF	.42	1.01	1.43
3/8" Oxygen Barrier PEX	P6@.019	LF	.38	1.01	1.39
3/8" ThermaPEX	P6@.019	LF	.50	1.01	1.51
3/8" hePEX	P6@.019	LF	.78	1.01	1.79
3/8" PEX fittings					
3/8" PEX brass elbow	P6@.160	Ea	.70	8.47	9.17
3/8" PEX brass coupler	P6@.160	Ea	.49	8.47	8.96
3/8" PEX crimp ring	P6@.008	Ea	.15	.42	.57
3/8" x 3/8" x 3/8" PEX brass tee	P6@.240	Ea	.52	12.70	13.22
3/8" PEX economy clamp	P6@.020	Ea	.10	1.06	1.16
1/2" PEX tube					
1/2" AQUAPEX, white	P6@.020	LF	.51	1.06	1.57
1/2" AQUAPEX, red or blue	P6@.020	LF	.52	1.06	1.58
1/2" PEX, red or blue	P6@.020	LF	.25	1.06	1.31
1/2" ViegaPEX, red or blue	P6@.020	LF	.47	1.06	1.53
1/2" Pre-Insulated AQUAPEX	P6@.020	LF	2.40	1.06	3.46
1/2" Oxygen Barrier PEX	P6@.020	LF	.24	1.06	1.30
1/2" ThermaPEX	P6@.020	LF	.56	1.06	1.62
1/2" hePEX	P6@.020	LF	.79	1.06	1.85
1/2" PEX fittings					
1/2" PEX brass elbow	P6@.160	Ea	.83	8.47	9.30
1/2" PEX brass coupler	P6@.160	Ea	.57	8.47	9.04
1/2" PEX ball valve	P6@.200	Ea	4.21	10.60	14.81
1/2" PEX crimp ring	P6@.008	Ea	.19	.42	.61
1/2" x 1/2" x 1/2" PEX brass tee	P6@.240	Ea	1.16	12.70	13.86
1/2" PEX x 1/2" copper pipe adapter	P6@.160	Ea	.71	8.47	9.18
1/2" PEX economy clamp	P6@.020	Ea	.17	1.06	1.23
1/2" PEX suspension clip	P6@.020	Ea	.22	1.06	1.28

22 Plumbing

	Craft@Hrs	Unit	Material	Labor	Total
5/8" PEX tube					
5/8" Oxygen Barrier PEX	P6@.021	LF	.37	1.11	1.48
5/8" ThermaPEX	P6@.021	LF	.76	1.11	1.87
5/8" hePEX	P6@.021	LF	1.03	1.11	2.14
5/8" PEX fittings					
5/8" PEX brass elbow	P6@.160	Ea	1.24	8.47	9.71
5/8" PEX brass coupler	P6@.160	Ea	.93	8.47	9.40
5/8" PEX crimp ring	P6@.009	Ea	.18	.48	.66
5/8" x 5/8" x 5/8" PEX brass tee	P6@.240	Ea	1.98	12.70	14.68
5/8" PEX x 1/2" copper pipe adapter	P6@.160	Ea	1.57	8.47	10.04
5/8" PEX x 3/4" copper pipe adapter	P6@.160	Ea	1.42	8.47	9.89
3/4" PEX tube					
3/4" AQUAPEX, white	P6@.021	LF	.85	1.11	1.96
3/4" AQUAPEX, red or blue	P6@.021	LF	.80	1.11	1.91
3/4" PEX, red or blue	P6@.021	LF	.42	1.11	1.53
3/4" ViegaPEX, red or blue	P6@.021	LF	.81	1.11	1.92
3/4" Pre-Insulated AQUAPEX	P6@.021	LF	3.19	1.11	4.30
3/4" Oxygen Barrier PEX	P6@.021	LF	.47	1.11	1.58
3/4" ThermaPEX	P6@.021	LF	.84	1.11	1.95
3/4" hePEX	P6@.021	LF	1.28	1.11	2.39
3/4" PEX fittings					
3/4" PEX brass elbow	P6@.160	Ea	1.30	8.47	9.77
3/4" PEX brass coupler	P6@.160	Ea	1.12	8.47	9.59
3/4" PEX ball valve	P6@.200	Ea	6.22	10.60	16.82
3/4" PEX crimp ring	P6@.009	Ea	.21	.48	.69
3/4" x 3/4" x 3/4" PEX brass tee	P6@.240	Ea	2.06	12.70	14.76
3/4" PEX x 3/4" copper pipe adapter	P6@.160	Ea	1.19	8.47	9.66
3/4" PEX economy clamp	P6@.160	Ea	.21	8.47	8.68
3/4" PEX suspension clip	P6@.020	Ea	.19	1.06	1.25
1" PEX tube					
1" AQUAPEX, white	P6@.025	LF	1.49	1.32	2.81
1" AQUAPEX, red or blue	P6@.025	LF	2.03	1.32	3.35
1" PEX, red or blue	P6@.025	LF	.65	1.32	1.97
1" ViegaPEX, red or blue	P6@.025	LF	1.84	1.32	3.16
1" Pre-Insulated AQUAPEX	P6@.025	LF	3.78	1.32	5.10
1" Oxygen Barrier PEX	P6@.025	LF	.74	1.32	2.06
1" ThermaPEX	P6@.025	LF	1.68	1.32	3.00
1" hePEX	P6@.025	LF	1.98	1.32	3.30
1" PEX fittings					
1" PEX brass elbow	P6@.200	Ea	2.10	10.60	12.70
1" PEX brass coupler	P6@.200	Ea	1.51	10.60	12.11
1" PEX x 1" copper pipe adapter	P6@.165	Ea	2.01	8.73	10.74
1" PEX ball valve	P6@.220	Ea	10.00	11.60	21.60
1" PEX crimp ring	P6@.010	Ea	.28	.53	.81
1" x 1" x 1" PEX brass tee	P6@.240	Ea	3.11	12.70	15.81
PEX manifolds					
1/2" 14 port manifold (6 hot, 8 cold)	P6@1.25	Ea	140.00	66.10	206.10
1/2" 18 port manifold (8 hot, 10 cold)	P6@1.50	Ea	163.00	79.40	242.40
1/2" 24 port manifold (9 hot, 15 cold)	P6@1.95	Ea	197.00	103.00	300.00
1/2" 36 port manifold (14 hot, 22 cold)	P6@2.90	Ea	289.00	153.00	442.00
1" copper manifold with 6 ports	P6@.600	Ea	17.60	31.70	49.30

22 Plumbing

	Craft@Hrs	Unit	Material	Labor	Total
1" copper manifold w/ 12 ports	P6@1.20	Ea	39.80	63.50	103.30
2-Loop radiant heat manifold	P6@1.00	Ea	197.00	52.90	249.90
4-Loop radiant heat manifold	P6@1.50	Ea	251.00	79.40	330.40
8-Loop radiant heat manifold	P6@1.00	Ea	407.00	52.90	459.90
PEX-AL Tube and Fittings Cross-linked polyethylene tube with aluminum middle layer, installed in a building vertically or horizontally up to 10' above floor level. Using crimped connections. By copper tube size. Based on 100' rolls of tube. For domestic water systems and in-floor hydronics heating systems.					
1/2" PEX-AL tube and fittings					
1/2" PEX-AL tubing	P6@.020	LF	.43	1.06	1.49
1/2" PEX-AL press coupling	P6@.160	Ea	8.41	8.47	16.88
1/2" PEX-AL x 3/4" male adapter	P6@.160	Ea	15.80	8.47	24.27
1/2" PEX-AL x 3/4" copper pipe adapter	P6@.180	Ea	8.72	9.52	18.24
1/2" PEX crimp ring	P6@.008	Ea	.19	.42	.61
1/2" x 1/2" x 1/2" PEX brass tee	P6@.240	Ea	1.16	12.70	13.86
1/2" PEX economy clamp	P6@.020	Ea	.17	1.06	1.23
1/2" PEX suspension clip	P6@.020	Ea	.22	1.06	1.28
5/8" PEX-AL tube and fittings					
5/8" PEX-AL tubing	P6@.021	LF	.65	1.11	1.76
5/8" PEX-AL press coupling	P6@.160	Ea	10.90	8.47	19.37
5/8" PEX-AL press elbow	P6@.160	Ea	10.50	8.47	18.97
5/8" PEX-AL x 3/4" male adapter	P6@.160	Ea	17.00	8.47	25.47
5/8" PEX-AL x 3/4" copper pipe adapter	P6@.180	Ea	15.60	9.52	25.12
5/8" PEX crimp ring	P6@.008	Ea	.18	.42	.60
5/8" x 5/8" x 5/8" PEX brass tee	P6@.240	Ea	1.98	12.70	14.68
5/8" PEX economy clamp	P6@.020	Ea	.17	1.06	1.23
5/8" PEX suspension clip	P6@.020	Ea	.22	1.06	1.28
3/4" PEX-AL tube and fittings					
3/4" PEX-AL tubing	P6@.021	LF	.92	1.11	2.03
3/4" PEX-AL press coupling	P6@.160	Ea	12.30	8.47	20.77
3/4" PEX-AL press elbow	P6@.160	Ea	19.80	8.47	28.27
3/4" PEX-AL press tee	P6@.240	Ea	19.10	12.70	31.80
3/4" PEX-AL x 3/4" male adapter	P6@.160	Ea	19.90	8.47	28.37
3/4" PEX-AL x 3/4" copper pipe adapter	P6@.180	Ea	18.60	9.52	28.12
3/4" PEX crimp ring	P6@.008	Ea	.21	.42	.63
3/4" x 5/8" x 5/8" PEX brass tee	P6@.240	Ea	2.06	12.70	14.76
3/4" PEX economy clamp	P6@.020	Ea	.21	1.06	1.27
3/4" PEX suspension clip	P6@.020	Ea	.19	1.06	1.25
1" PEX-AL tube and fittings					
1" PEX-AL tubing	P6@.025	LF	1.33	1.32	2.65
1" PEX-AL press coupling	P6@.160	Ea	17.80	8.47	26.27
1" PEX-AL press elbow	P6@.160	Ea	42.20	8.47	50.67
1" PEX-AL press tee	P6@.240	Ea	26.20	12.70	38.90
1" PEX-AL x 3/4" male adapter	P6@.160	Ea	18.90	8.47	27.37
1" PEX-AL x 3/4" copper pipe adapter	P6@.180	Ea	36.10	9.52	45.62
1" PEX crimp ring	P6@.008	Ea	.28	.42	.70
1" x 5/8" x 5/8" PEX brass tee	P6@.240	Ea	3.11	12.70	15.81
1" PEX economy clamp	P6@.020	Ea	.21	1.06	1.27
1" PEX suspension clip	P6@.020	Ea	.19	1.06	1.25

22 Plumbing

	Craft@Hrs	Unit	Material	Labor	Total
Copper DWV Pipe and Fittings Straight rigid lengths. For commercial drain, waste and vent (DWV) systems. Labor assumes soldered joints with pipe installed vertically in a building up to 10' above floor level. Add the cost of supports.					
1-1/4" copper DWV pipe and fittings					
Cut pipe, per foot	P6@.042	LF	19.00	2.22	21.22
10' lengths	P6@.042	LF	4.85	2.22	7.07
Coupling	P6@.200	Ea	5.09	10.60	15.69
90-degree elbow	P6@.200	Ea	9.47	10.60	20.07
45-degree elbow	P6@.200	Ea	5.83	10.60	16.43
Tee	P6@.240	Ea	12.50	12.70	25.20
Trap adapter	P6@.145	Ea	19.30	7.67	26.97
1-1/2" copper DWV pipe and fittings					
Cut pipe, per foot	P6@.045	LF	18.70	2.38	21.08
10' lengths	P6@.045	LF	6.17	2.38	8.55
Coupling	P6@.200	Ea	9.59	10.60	20.19
90-degree elbow	P6@.350	Ea	12.90	18.50	31.40
45-degree elbow	P6@.200	Ea	7.13	10.60	17.73
Wye, cast brass	P6@.240	Ea	103.00	12.70	115.70
Tee	P6@.240	Ea	23.90	12.70	36.60
Test cap	P6@.075	Ea	1.83	3.97	5.80
Male adapter, C x MIP	P6@.150	Ea	15.40	7.94	23.34
Female adapter, FTG x C	P6@.200	Ea	10.10	10.60	20.70
Trap adapter	P6@.155	Ea	11.40	8.20	19.60
Trap adapter, with cleanout	P6@.235	Ea	48.70	12.40	61.10
2" copper DWV pipe and fittings					
Cut pipe, per foot	P6@.056	LF	27.00	2.96	29.96
10' lengths	P6@.056	LF	7.93	2.96	10.89
Coupling	P6@.270	Ea	6.71	14.30	21.01
90-degree elbow	P6@.270	Ea	19.00	14.30	33.30
45-degree elbow	P6@.270	Ea	17.60	14.30	31.90
Reducing bushing, 2" to 1-1/2"	P6@.140	Ea	10.00	7.41	17.41
Wye, cast brass	P6@.320	Ea	181.00	16.90	197.90
Tee, 2" x 2" x 2"	P6@.320	Ea	30.50	16.90	47.40
Tee, 2" x 2" x 1-1/2"	P6@.240	Ea	28.20	12.70	40.90
Male adapter C x MIP	P6@.185	Ea	20.20	9.79	29.99
Female adapter C x FIP	P6@.259	Ea	19.10	13.70	32.80
Trap adapter, with cleanout	P6@.325	Ea	54.60	17.20	71.80
PVC SDR 35 DWV Drainage Pipe Solvent weld, installed in an open trench inside a building (main building drain), including typical fittings (one wye and 45-degree elbow every 20'). SDR 35 is thin wall pipe suitable for below grade applications only. Add for excavation and backfill. Use these figures for preliminary estimates.					
3" pipe assembly below grade	P6@.160	LF	3.19	8.47	11.66
4" pipe assembly below grade	P6@.175	LF	4.89	9.26	14.15
6" pipe assembly below grade	P6@.220	LF	10.30	11.60	21.90
Add for interior excavation and backfill (shallow)	CL@.180	LF	—	7.50	7.50
ABS DWV Pipe and Fittings Acrylonitrile Butadiene Styrene (ASTM D 2661-73) pipe is made from rubber-based resins and used primarily for drain, waste and vent systems. The Uniform Plumbing Code limits ABS to residential buildings and below grade applications in commercial and public buildings. Solvent-weld ABS is easier to install than cast iron or copper drainage pipe. ABS does not rot, rust, corrode or collect waste and resists mechanical damage, even at low temperatures.					
1-1/2" pipe, 10' lengths	P6@.020	LF	.82	1.06	1.88
2" pipe, 10' lengths	P6@.025	LF	1.14	1.32	2.46
3" pipe, 10' lengths	P6@.030	LF	2.25	1.59	3.84
4" pipe, 10' lengths	P6@.040	LF	3.19	2.12	5.31
Deduct for below grade applications	—	%	—	-15.0	—

22 Plumbing

	Craft@Hrs	Unit	Material	Labor	Total
ABS 90-degree elbow (1/4 bend), hub and hub except as noted. Street elbows are hub and spigot.					
1-1/2" ell	P6@.060	Ea	1.73	3.17	4.90
1-1/2" long sweep	P6@.200	Ea	3.12	10.60	13.72
1-1/2" street ell	P6@.120	Ea	2.99	6.35	9.34
1-1/2" venting	P6@.150	Ea	2.28	7.94	10.22
2" ell	P6@.125	Ea	2.25	6.61	8.86
2", long sweep	P6@.250	Ea	4.03	13.20	17.23
2", street ell	P6@.125	Ea	4.01	6.61	10.62
2", venting	P6@.150	Ea	3.98	7.94	11.92
3" ell	P6@.175	Ea	6.21	9.26	15.47
3", long sweep	P6@.500	Ea	8.02	26.50	34.52
3", street ell	P6@.150	Ea	7.31	7.94	15.25
3", venting	P6@.150	Ea	9.45	7.94	17.39
3" x 3" x 1-1/2", hub x hub x hub, side inlet	P6@.500	Ea	14.60	26.50	41.10
3" x 3" x 2", hub x hub x hub, side inlet	P6@.500	Ea	16.50	26.50	43.00
3" x 3" x 2" low heel elbow	P6@.500	Ea	9.36	26.50	35.86
3" x 3" x 1-1/2" low heel elbow	P6@.175	Ea	14.30	9.26	23.56
4" ell	P6@.175	Ea	10.50	9.26	19.76
4", long sweep	P6@.500	Ea	16.70	26.50	43.20
4", street ell	P6@.175	Ea	15.90	9.26	25.16
4" x 3" closet elbow, spigot x hub	P6@.150	Ea	15.00	7.94	22.94
4" x 3" closet elbow, hub x hub	P6@.260	Ea	9.90	13.80	23.70
ABS 60-degree elbow (1/6 bend), hub and hub					
1-1/2" bend	P6@.200	Ea	2.79	10.60	13.39
2" bend	P6@.250	Ea	3.65	13.20	16.85
3" bend	P6@.500	Ea	14.20	26.50	40.70
4" bend	P6@.500	Ea	21.50	26.50	48.00
ABS 45-degree elbow (1/8 bend). Regular bends are hub x hub. Street bends are hub and spigot.					
1-1/2" bend	P6@.120	Ea	1.98	6.35	8.33
1-1/2" street bend	P6@.120	Ea	1.94	6.35	8.29
2" bend	P6@.125	Ea	2.99	6.61	9.60
2" street bend	P6@.125	Ea	2.62	6.61	9.23
3" bend	P6@.175	Ea	6.43	9.26	15.69
3" street bend	P6@.150	Ea	5.41	7.94	13.35
4" bend	P6@.175	Ea	11.40	9.26	20.66
4" street bend	P6@.175	Ea	11.60	9.26	20.86
ABS 22-1/2 degree elbow (1/16 bend). Regular bends are hub x hub. Street bends are hub and spigot.					
1-1/2" bend	P6@.120	Ea	2.31	6.35	8.66
1-1/2", street bend	P6@.120	Ea	6.52	6.35	12.87
2" bend	P6@.125	Ea	2.99	6.61	9.60
2", street bend	P6@.125	Ea	6.09	6.61	12.70
3" bend	P6@.170	Ea	10.00	8.99	18.99
3" street bend	P6@.150	Ea	12.90	7.94	20.84
4" bend	P6@.175	Ea	10.60	9.26	19.86
4" street bend	P6@.175	Ea	17.10	9.26	26.36
ABS coupling, hub x hub					
1-1/2"	P6@.120	Ea	1.00	6.35	7.35
2"	P6@.125	Ea	1.34	6.61	7.95
2" x 1-1/2", reducing	P6@.125	Ea	3.39	6.61	10.00
3"	P6@.175	Ea	2.64	9.26	11.90
3" x 2", reducing	P6@.175	Ea	6.92	9.26	16.18
4"	P6@.250	Ea	5.08	13.20	18.28
4" x 3", reducing	P6@.250	Ea	10.80	13.20	24.00

22 Plumbing

	Craft@Hrs	Unit	Material	Labor	Total
ABS wye, connects two branch lines to a main horizontal drain line. Hub x hub x hub.					
1-1/2"	P6@.150	Ea	3.76	7.94	11.70
2"	P6@.190	Ea	4.76	10.10	14.86
2" x 1-1/2"	P6@.190	Ea	6.53	10.10	16.63
3"	P6@.260	Ea	9.16	13.80	22.96
3" x 1-1/2"	P6@.240	Ea	9.12	12.70	21.82
3" x 2"	P6@.260	Ea	7.83	13.80	21.63
4"	P6@.350	Ea	18.60	18.50	37.10
4" x 2"	P6@.350	Ea	14.20	18.50	32.70
4" x 3"	P6@.360	Ea	16.00	19.00	35.00
ABS double wye, joins three ABS branch lines to a main horizontal drain line. Hub x hub x hub x hub.					
1-1/2"	P6@.260	Ea	7.34	13.80	21.14
2"	P6@.290	Ea	8.58	15.30	23.88
3"	P6@.325	Ea	20.40	17.20	37.60
4" x 3"	P6@.350	Ea	31.90	18.50	50.40
ABS sanitary tee (TY), connects a branch line to a vertical ABS drain line. Regular sanitary tees are hub x hub x hub. Street sanitary tees are spigot x hub x hub.					
1-1/2"	P6@.150	Ea	2.54	7.94	10.48
1-1/2", long sweep	P6@.150	Ea	7.10	7.94	15.04
1-1/2", street tee	P6@.150	Ea	6.63	7.94	14.57
2" x 1-1/2"	P6@.160	Ea	2.33	8.47	10.80
2" x 1-1/2" x 1-1/2"	P6@.160	Ea	3.51	8.47	11.98
2" x 1-1/2" x 2"	P6@.160	Ea	3.57	8.47	12.04
2"	P6@.190	Ea	3.83	10.10	13.93
2", long sweep	P6@.190	Ea	8.18	10.10	18.28
2" x 1-1/2", long sweep	P6@.190	Ea	8.15	10.10	18.25
2" street tee	P6@.190	Ea	7.80	10.10	17.90
2" x 1-1/2" x 1-1/2" street tee	P6@.190	Ea	8.68	10.10	18.78
3"	P6@.260	Ea	8.82	13.80	22.62
3", long sweep	P6@.260	Ea	13.10	13.80	26.90
3" x 1-1/2"	P6@.210	Ea	6.74	11.10	17.84
3" x 1-1/2", long sweep	P6@.200	Ea	11.60	10.60	22.20
3" x 2"	P6@.235	Ea	7.75	12.40	20.15
3" x 2", long sweep	P6@.260	Ea	8.79	13.80	22.59
4"	P6@.350	Ea	15.80	18.50	34.30
4", long sweep	P6@.350	Ea	19.10	18.50	37.60
4" x 2"	P6@.275	Ea	15.90	14.60	30.50
4" x 2", long sweep	P6@.350	Ea	22.10	18.50	40.60
4" x 3"	P6@.325	Ea	16.80	17.20	34.00
4" x 3", long sweep	P6@.360	Ea	25.60	19.00	44.60
ABS bungalow fitting (Wisconsin tee). Connects vent (3" top inlet) and horizontal water closet discharge (3" branch) and bathtub discharge (1-1/2" branch) to a vertical soil stack. One fitting connects discharge and venting for a set of washroom fixtures.					
3", 1-1/2" left inlet	P6@.325	Ea	16.50	17.20	33.70
3", 2" right inlet	P6@.325	Ea	19.20	17.20	36.40
ABS double sanitary tee (double TY/cross), brings two ABS-DWV branch lines into a vertical waste or soil stack. All hub except as noted.					
1-1/2"	P6@.250	Ea	6.65	13.20	19.85
2" x 1-1/2"	P6@.260	Ea	6.84	13.80	20.64
2"	P6@.290	Ea	8.80	15.30	24.10
2" double fixture tee	P6@.290	Ea	13.50	15.30	28.80
2" x 1-1/2" x 1-1/2" x 1-1/2"	P6@.260	Ea	7.31	13.80	21.11

22 Plumbing

	Craft@Hrs	Unit	Material	Labor	Total
3"	P6@.325	Ea	21.50	17.20	38.70
3" double fixture tee, spigot x hub	P6@.450	Ea	29.70	23.80	53.50
3" x 1-1/2"	P6@.310	Ea	6.48	16.40	22.88
3" x 2"	P6@.335	Ea	11.90	17.70	29.60
4"	P6@.350	Ea	44.10	18.50	62.60
ABS cleanout tee, two-way					
3", hub x hub x hub	P6@.175	Ea	20.20	9.26	29.46
4", hub x hub x hub	P6@.250	Ea	42.70	13.20	55.90
ABS test tee, provides a cleanout opening flush with a finished wall. Includes a cleanout plug. FIPT means female iron pipe thread.					
1-1/2", hub x hub x cleanout	P6@.130	Ea	7.33	6.88	14.21
2", hub x hub x cleanout	P6@.170	Ea	11.50	8.99	20.49
3", hub x hub x cleanout	P6@.220	Ea	19.70	11.60	31.30
4", hub x hub x cleanout	P6@.240	Ea	35.30	12.70	48.00
1-1/2", hub x hub x FIPT	P6@.150	Ea	6.04	7.94	13.98
2", hub x hub x FIPT	P6@.190	Ea	7.24	10.10	17.34
3", hub x hub x FIPT	P6@.260	Ea	14.10	13.80	27.90
4", hub x hub x FIPT	P6@.350	Ea	20.10	18.50	38.60
Inset test cap with knockout					
1-1/2"	P6@.100	Ea	.57	5.29	5.86
2"	P6@.100	Ea	.55	5.29	5.84
3"	P6@.100	Ea	.65	5.29	5.94
4"	P6@.100	Ea	.70	5.29	5.99
Mechanical plastic test plug with galvanized wing nut, natural rubber O-ring. Max air pressure of 5 psi.					
1-1/2"	P6@.030	Ea	4.38	1.59	5.97
2"	P6@.030	Ea	5.72	1.59	7.31
3"	P6@.030	Ea	7.08	1.59	8.67
4"	P6@.030	Ea	8.71	1.59	10.30
ABS closet flange. Closet flanges are used for mounting water closets.					
4" x 3", fast set with test cap	P6@.225	Ea	17.10	11.90	29.00
4" x 3", closet flange x hub	P6@.225	Ea	11.00	11.90	22.90
4" x 3", closet adjustable flange x hub	P6@.225	Ea	15.90	11.90	27.80
4" x 3", offset, adjustabe	P6@.225	Ea	16.10	11.90	28.00
4", closet flange x hub	P6@.225	Ea	14.90	11.90	26.80
4", fast set with test cap	P6@.225	Ea	12.40	11.90	24.30
4", closet adjustable flange x hub	P6@.225	Ea	14.60	11.90	26.50
ABS female adapter, joins ABS pipe to standard male threaded pipe. FIPT means female iron pipe thread.					
1-1/2", hub x FIPT	P6@.080	Ea	2.09	4.23	6.32
1-1/2", spigot x FIPT	P6@.080	Ea	2.12	4.23	6.35
2", hub x FIPT	P6@.085	Ea	3.70	4.50	8.20
2", spigot x FIPT	P6@.085	Ea	2.60	4.50	7.10
3", hub x FIPT	P6@.155	Ea	6.28	8.20	14.48
3", spigot x FIPT	P6@.155	Ea	6.08	8.20	14.28
4", hub x FIPT	P6@.220	Ea	10.20	11.60	21.80
4", spigot x FIPT	P6@.220	Ea	10.10	11.60	21.70
ABS male adapter, joins ABS pipe to standard female threaded pipe. MIPT means male iron pipe thread.					
1-1/2", hub x MIPT	P6@.080	Ea	1.75	4.23	5.98
2", hub x MIPT	P6@.085	Ea	2.68	4.50	7.18
3", hub x MIPT	P6@.155	Ea	5.71	8.20	13.91
4", hub x MIPT	P6@.220	Ea	12.80	11.60	24.40

22 Plumbing

	Craft@Hrs	Unit	Material	Labor	Total
ABS trap adapter, joins ABS pipe to sink or bath waste outlet.					
1-1/2", hub x slip jam nut	P6@.200	Ea	2.35	10.60	12.95
1-1/2", spigot x slip jam nut	P6@.200	Ea	2.78	10.60	13.38
1-1/2" x 1-1/4", spigot x slip jam nut	P6@.200	Ea	2.09	10.60	12.69
1-1/2" x 1-1/4", hub x slip jam nut	P6@.200	Ea	2.79	10.60	13.39
ABS cleanout adapter, fits inside pipe, flush finish.					
2", insert	P6@.100	Ea	5.33	5.29	10.62
3", insert	P6@.150	Ea	6.03	7.94	13.97
4", insert	P6@.320	Ea	8.79	16.90	25.69
ABS-DWV cleanout plug, male pipe threads.					
1-1/2"	P6@.090	Ea	1.55	4.76	6.31
2"	P6@.120	Ea	1.82	6.35	8.17
3"	P6@.240	Ea	2.77	12.70	15.47
4"	P6@.320	Ea	4.83	16.90	21.73
2", countersunk	P6@.120	Ea	2.23	6.35	8.58
3", countersunk	P6@.240	Ea	2.67	12.70	15.37
ABS soil pipe adapter, joins ABS DWV to cast iron pipe soil pipe.					
3" ABS hub x cast iron spigot	P6@.155	Ea	8.79	8.20	16.99
4" ABS hub to cast iron spigot	P6@.250	Ea	13.20	13.20	26.40
4" cast iron spigot to 3" DWV hub	P6@.220	Ea	9.99	11.60	21.59
ABS P-trap, used at fixture waste outlets to prevent sewer gas from entering living space via the fixture drain.					
1-1/2", all hub	P6@.220	Ea	4.74	11.60	16.34
1-1/2", hub x hub, with union	P6@.280	Ea	6.09	14.80	20.89
1-1/2", hub, with cleanout	P6@.155	Ea	12.80	8.20	21.00
1-1/2", hub x spigot, with union	P6@.220	Ea	8.27	11.60	19.87
2", all hub	P6@.280	Ea	7.91	14.80	22.71
2", hub x hub, with union	P6@.280	Ea	12.30	14.80	27.10
2", hub, with cleanout	P6@.195	Ea	15.10	10.30	25.40
ABS return bend, bottom portion of P-trap, no cleanout.					
1-1/2", all hub	P6@.120	Ea	4.15	6.35	10.50
2", all hub	P6@.125	Ea	6.56	6.61	13.17
ABS cap, permanently caps ABS-DWV piping.					
1-1/2"	P6@.030	Ea	3.79	1.59	5.38
2"	P6@.040	Ea	5.80	2.12	7.92
3"	P6@.050	Ea	9.33	2.65	11.98
4"	P6@.090	Ea	11.50	4.76	16.26
ABS flush bushing, inserts into ABS fitting hub to reduce to a smaller pipe size.					
2" x 1-1/2"	P6@.062	Ea	1.59	3.28	4.87
3" x 1-1/2"	P6@.088	Ea	4.70	4.66	9.36
3" x 2"	P6@.088	Ea	3.89	4.66	8.55
4" x 2"	P6@.125	Ea	10.70	6.61	17.31
4" x 3"	P6@.125	Ea	9.67	6.61	16.28
ABS heavy-duty floor drain					
3", less sediment bucket	P6@.280	Ea	58.60	14.80	73.40
4", less sediment bucket	P6@.300	Ea	59.30	15.90	75.20
Hangers and Supports					
Angle bracket hangers, steel, by rod size					
3/8" angle bracket hanger	M5@.070	Ea	2.47	3.67	6.14
1/2" angle bracket hanger	M5@.070	Ea	2.80	3.67	6.47
5/8" angle bracket hanger	M5@.070	Ea	6.13	3.67	9.80
3/4" angle bracket hanger	M5@.070	Ea	9.48	3.67	13.15
7/8" angle bracket hanger	M5@.070	Ea	17.00	3.67	20.67

22 Plumbing

	Craft@Hrs	Unit	Material	Labor	Total
Angle supports, wall mounted, welded steel					
12" x 18", medium weight	M5@.950	Ea	106.00	49.80	155.80
18" x 24", medium weight	M5@1.10	Ea	133.00	57.60	190.60
24" x 30", medium weight	M5@1.60	Ea	169.00	83.80	252.80
12" x 30", heavy weight	M5@1.10	Ea	152.00	57.60	209.60
18" x 24", heavy weight	M5@1.10	Ea	214.00	57.60	271.60
24" x 30", heavy weight	M5@1.60	Ea	238.00	83.80	321.80
C-clamps with lock nut, steel, by rod size					
3/8" C-clamp	M5@.070	Ea	2.53	3.67	6.20
1/2" C-clamp	M5@.070	Ea	3.10	3.67	6.77
5/8" C-clamp	M5@.070	Ea	6.28	3.67	9.95
3/4" C-clamp	M5@.070	Ea	9.02	3.67	12.69
7/8" C-clamp	M5@.070	Ea	24.20	3.67	27.87
Top beam clamps, steel, by rod size					
3/8" top beam clamp	M5@.070	Ea	3.01	3.67	6.68
1/2" top beam clamp	M5@.070	Ea	4.87	3.67	8.54
5/8" top beam clamp	M5@.070	Ea	5.98	3.67	9.65
3/4" top beam clamp	M5@.070	Ea	8.73	3.67	12.40
7/8" top beam clamp	M5@.070	Ea	11.60	3.67	15.27
Clevis hangers, standard duty, by intended pipe size, no threaded rod or beam clamp included					
1/2" clevis hanger	M5@.156	Ea	2.35	8.17	10.52
3/4" clevis hanger	M5@.156	Ea	2.35	8.17	10.52
1" clevis hanger	M5@.156	Ea	2.48	8.17	10.65
1-1/4" clevis hanger	M5@.173	Ea	2.87	9.06	11.93
1-1/2" clevis hanger	M5@.173	Ea	3.13	9.06	12.19
2" clevis hanger	M5@.173	Ea	3.48	9.06	12.54
2-1/2" clevis hanger	M5@.189	Ea	3.69	9.90	13.59
3" clevis hanger	M5@.189	Ea	4.87	9.90	14.77
4" clevis hanger	M5@.189	Ea	6.03	9.90	15.93
6" clevis hanger	M5@.202	Ea	10.20	10.60	20.80
8" clevis hanger	M5@.202	Ea	14.90	10.60	25.50
Add for epoxy coated	—	%	25.0	—	—
Add for copper plated	—	%	35.0	—	—
Deduct for light duty	—	%	-20.0	—	—
Swivel ring hangers, light duty, by intended pipe size, band hanger, galvanized steel, no hanger rod, beam clamp or insert included					
1/2" swivel ring hanger	M5@.125	Ea	.61	6.55	7.16
3/4" swivel ring hanger	M5@.125	Ea	.61	6.55	7.16
1" swivel ring hanger	M5@.125	Ea	.61	6.55	7.16
1-1/4" swivel ring hanger	M5@.125	Ea	.69	6.55	7.24
1-1/2" swivel ring hanger	M5@.125	Ea	.79	6.55	7.34
2" swivel ring hanger	M5@.125	Ea	.95	6.55	7.50
2-1/2" swivel ring hanger	M5@.135	Ea	1.28	7.07	8.35
3" swivel ring hanger	M5@.135	Ea	1.54	7.07	8.61
4" swivel ring hanger	M5@.135	Ea	2.14	7.07	9.21
6" swivel ring hanger	M5@.145	Ea	4.01	7.59	11.60
8" swivel ring hanger	M5@.145	Ea	4.80	7.59	12.39
Add for epoxy coating	—	%	45.0	—	—
Add for copper plated	—	%	55.0	—	—
Riser clamps, carbon steel, by intended pipe size					
1/2" riser clamp	M5@.100	Ea	2.02	5.24	7.26
3/4" riser clamp	M5@.100	Ea	2.98	5.24	8.22
1" riser clamp	M5@.100	Ea	3.04	5.24	8.28

22 Plumbing

	Craft@Hrs	Unit	Material	Labor	Total
1-1/4" riser clamp	M5@.115	Ea	3.61	6.02	9.63
1-1/2" riser clamp	M5@.115	Ea	3.85	6.02	9.87
2" riser clamp	M5@.125	Ea	4.04	6.55	10.59
2-1/2" riser clamp	M5@.135	Ea	4.24	7.07	11.31
3" riser clamp	M5@.140	Ea	4.66	7.33	11.99
4" riser clamp	M5@.145	Ea	5.87	7.59	13.46
6" riser clamp	M5@.155	Ea	10.20	8.12	18.32
8" riser clamp	M5@.165	Ea	16.60	8.64	25.24
Add for epoxy coating	—	%	25.0	—	—
Add for copper plated	—	%	35.0	—	—
Pipe clamps, medium duty, by intended pipe size					
3" pipe clamp	M5@.189	Ea	6.12	9.90	16.02
4" pipe clamp	M5@.189	Ea	8.73	9.90	18.63
6" pipe clamp	M5@.202	Ea	21.40	10.60	32.00
Pipe rolls					
3" pipe roll, complete	M5@.403	Ea	19.10	21.10	40.20
4" pipe roll, complete	M5@.518	Ea	20.00	27.10	47.10
6" pipe roll, complete	M5@.518	Ea	20.00	27.10	47.10
8" pipe roll, complete	M5@.578	Ea	35.20	30.30	65.50
3" pipe roll stand, complete	M5@.323	Ea	51.00	16.90	67.90
4" pipe roll stand, complete	M5@.604	Ea	76.00	31.60	107.60
6" pipe roll stand, complete	M5@.775	Ea	76.00	40.60	116.60
8" pipe roll stand, complete	M5@.775	Ea	133.00	40.60	173.60
Pipe straps, galvanized, two hole, lightweight					
2-1/2" pipe strap	M5@.119	Ea	2.42	6.23	8.65
3" pipe strap	M5@.128	Ea	3.13	6.70	9.83
3-1/2" pipe strap	M5@.135	Ea	3.98	7.07	11.05
4" pipe strap	M5@.144	Ea	4.43	7.54	11.97
Plumber's tape, galvanized, 3/4" x 10' roll					
26 gauge	—	LF	2.15	—	2.15
22 gauge	—	LF	2.84	—	2.84
Sliding pipe guides, welded					
3" pipe guide	M5@.354	Ea	21.90	18.50	40.40
4" pipe guide	M5@.354	Ea	29.40	18.50	47.90
6" pipe guide	M5@.354	Ea	42.40	18.50	60.90
8" pipe guide	M5@.471	Ea	63.70	24.70	88.40
Wall sleeves, cast iron					
4" sleeve	M5@.241	Ea	9.43	12.60	22.03
6" sleeve	M5@.284	Ea	11.80	14.90	26.70
8" sleeve	M5@.377	Ea	15.40	19.70	35.10
Threaded hanger rod, by rod size, in 6' to 10' lengths, per LF					
3/8" rod	—	LF	.50	—	.50
1/2" rod	—	LF	.77	—	.77
5/8" rod	—	LF	1.02	—	1.02
3/4" rod	—	LF	1.73	—	1.73
U-bolts, with hex nuts, light duty					
4" U-bolt	M5@.089	Ea	6.62	4.66	11.28
6" U-bolt	M5@.135	Ea	12.20	7.07	19.27

22 Plumbing

	Craft@Hrs	Unit	Material	Labor	Total
Gate Valves , for water, gas and steam applications; complies with American Society of Mechanical Engineers Standard B16, Manufacturers Standardization Society, Instrumentation Society of America standards.					
1/2" bronze gate valves					
125 lb, threaded	P6@.210	Ea	14.60	11.10	25.70
125 lb, soldered	P6@.200	Ea	14.20	10.60	24.80
150 lb, threaded	P6@.210	Ea	25.20	11.10	36.30
200 lb, threaded	P6@.210	Ea	33.10	11.10	44.20
3/4" bronze gate valves					
125 lb, threaded	P6@.250	Ea	17.70	13.20	30.90
125 lb, soldered	P6@.240	Ea	16.60	12.70	29.30
150 lb, threaded	P6@.250	Ea	34.70	13.20	47.90
200 lb, threaded	P6@.250	Ea	43.10	13.20	56.30
1" bronze gate valves					
125 lb, threaded	P6@.300	Ea	25.10	15.90	41.00
125 lb, soldered	P6@.290	Ea	24.70	15.30	40.00
150 lb, threaded	P6@.300	Ea	40.70	15.90	56.60
200 lb, threaded	P6@.300	Ea	53.10	15.90	69.00
1-1/2" bronze gate valves					
125 lb, threaded	P6@.450	Ea	41.70	23.80	65.50
125 lb, soldered	P6@.440	Ea	40.40	23.30	63.70
150 lb, threaded	P6@.450	Ea	73.40	23.80	97.20
200 lb, threaded	P6@.450	Ea	89.40	23.80	113.20
2" bronze gate valves					
125 lb, threaded	P6@.500	Ea	69.80	26.50	96.30
125 lb, soldered	P6@.480	Ea	67.70	25.40	93.10
150 lb, threaded	P6@.500	Ea	115.00	26.50	141.50
200 lb, threaded	P6@.500	Ea	132.00	26.50	158.50
Cast iron, bronze trim, non-rising stem					
2-1/2" 125 lb, cast iron, flanged	Ml@.600	Ea	294.00	33.60	327.60
2-1/2" 250 lb, cast iron, flanged	Ml@.600	Ea	576.00	33.60	609.60
3" 125 lb, cast iron, flanged	Ml@.750	Ea	318.00	42.00	360.00
4" 125 lb, cast iron, flanged	Ml@1.35	Ea	468.00	75.50	543.50
4" 250 lb, cast iron, flanged	Ml@1.35	Ea	1,190.00	75.50	1,265.50

Steel Gate, Globe and Check Valves

Cast steel Class 150 gate valves, OS&Y, flanged ends

2-1/2" valve	Ml@.600	Ea	1,160.00	33.60	1,193.60
3" valve	Ml@.750	Ea	1,160.00	42.00	1,202.00
4" valve	Ml@1.35	Ea	1,430.00	75.50	1,505.50

Cast steel Class 300 gate valves, OS&Y, flanged ends

2-1/2" valve	Ml@.600	Ea	1,550.00	33.60	1,583.60
3" valve	Ml@.750	Ea	1,550.00	42.00	1,592.00
4" valve	Ml@1.35	Ea	2,110.00	75.50	2,185.50



OS&Y Gate Valves Forged steel class 800 bolted bonnet outside stem and yoke valves for water, gas and steam applications, complies with American Society of Mechanical Engineers Standard B16, Manufacturers Standardization Society, Instrumentation Society of America standards.

Threaded ends OS&Y gate valves

1/2" valve	P6@.210	Ea	123.00	11.10	134.10
3/4" valve	P6@.250	Ea	167.00	13.20	180.20
1" valve	P6@.300	Ea	303.00	15.90	318.90
1-1/2" valve	P6@.450	Ea	382.00	23.80	405.80
2" valve	P6@.500	Ea	585.00	26.50	611.50



22 Plumbing

	Craft@Hrs	Unit	Material	Labor	Total
2-1/2" flanged iron OS&Y gate valves					
125 lb	MI@.600	Ea	405.00	33.60	438.60
250 lb	MI@.600	Ea	914.00	33.60	947.60
3" flanged iron OS&Y gate valves					
125 lb	MI@.750	Ea	431.00	42.00	473.00
250 lb	MI@.750	Ea	1,050.00	42.00	1,092.00
4" flanged iron OS&Y gate valves					
125 lb	MI@1.35	Ea	597.00	75.50	672.50
250 lb	MI@1.35	Ea	1,550.00	75.50	1,625.50
6" flanged iron OS&Y gate valves					
125 lb	MI@2.50	Ea	1,020.00	140.00	1,160.00
250 lb	MI@2.50	Ea	2,520.00	140.00	2,660.00

Butterfly Valves, Ductile Iron

Wafer body, flanged, with lever lock, 150 lb valves have aluminum bronze disk, stainless steel stem and EPDM seals. 200 lb nickel plated ductile iron disk and Buna-N seals.

2-1/2" butterfly valve					
150 lb	MI@.300	Ea	132.00	16.80	148.80
200 lb	MI@.400	Ea	190.00	22.40	212.40
3" butterfly valve					
150 lb	MI@.400	Ea	146.00	22.40	168.40
200 lb	MI@.450	Ea	201.00	25.20	226.20
4" butterfly valve					
150 lb	MI@.500	Ea	180.00	28.00	208.00
200 lb	MI@.550	Ea	249.00	30.80	279.80
6" butterfly valve					
150 lb	MI@.750	Ea	284.00	42.00	326.00
200 lb	MI@.750	Ea	400.00	42.00	442.00
8" butterfly valve, with gear operator					
150 lb	MI@.950	Ea	401.00	53.10	454.10
200 lb	MI@.950	Ea	736.00	53.10	789.10
10" butterfly valve, with gear operator					
150 lb	MI@1.40	Ea	563.00	78.30	641.30
200 lb	MI@1.40	Ea	943.00	78.30	1,021.30

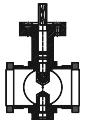
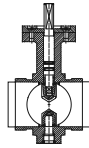

Bronze Globe Valves 125 lb and 150 lb ratings are saturated steam pressure. 200 lb rating is working steam pressure, union bonnet. 125 lb valves have bronze disks. 150 lb valves have composition disks. 300 lb valves have regrinding disks. For gas and steam applications, complies with American Society of Mechanical Engineers Standard B16, Manufacturers Standardization Society, Instrumentation Society of America and American Petroleum Institute standards.

1/2" threaded bronze globe valves					
125 lb	P6@.210	Ea	19.30	11.10	30.40
150 lb	P6@.210	Ea	34.20	11.10	45.30
300 lb	P6@.210	Ea	51.50	11.10	62.60
3/4" threaded bronze globe valves					
125 lb	P6@.250	Ea	26.00	13.20	39.20
150 lb	P6@.250	Ea	46.70	13.20	59.90
300 lb	P6@.250	Ea	65.40	13.20	78.60
1" threaded bronze globe valves					
125 lb	P6@.300	Ea	37.40	15.90	53.30
150 lb	P6@.300	Ea	72.50	15.90	88.40
300 lb	P6@.300	Ea	94.20	15.90	110.10
1-1/2" threaded bronze globe valves					
125 lb	P6@.450	Ea	70.50	23.80	94.30
150 lb	P6@.450	Ea	137.00	23.80	160.80
300 lb	P6@.450	Ea	181.00	23.80	204.80

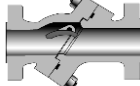
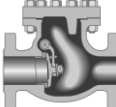

22 Plumbing

	Craft@Hrs	Unit	Material	Labor	Total
2" threaded bronze globe valves					
125 lb	P6@.500	Ea	114.00	26.50	140.50
150 lb	P6@.500	Ea	206.00	26.50	232.50
300 lb	P6@.500	Ea	249.00	26.50	275.50
Iron Body Globe Valves Flanged, iron body, OS&Y (outside stem & yoke) 125 psi steam pressure and 200 psi cold water pressure rated.					
3" flanged OS&Y, globe valve	MI@.750	Ea	531.00	42.00	573.00
3" 250 lb	MI@.750	Ea	1,030.00	42.00	1,072.00
4" flanged OS&Y, globe valve	MI@1.35	Ea	751.00	75.50	826.50
4" 250 lb	MI@1.35	Ea	973.00	75.50	1,048.50
6" flanged OS&Y, globe valve	MI@2.50	Ea	1,400.00	140.00	1,540.00
6" 250 lb	MI@2.50	Ea	2,520.00	140.00	2,660.00
8" flanged OS&Y, globe valve	MI@3.00	Ea	2,460.00	168.00	2,628.00
8" 250 lb	MI@3.00	Ea	4,340.00	168.00	4,508.00
					
Swing Check Valves for water and steam applications, complies with American Society of Mechanical Engineers Standard B16, Manufacturers Standardization Society, Instrumentation Society of America standards.					
1/2" bronze check valves					
125 lb, threaded, swing	P6@.210	Ea	16.00	11.10	27.10
125 lb, soldered, swing	P6@.200	Ea	15.70	10.60	26.30
125 lb, threaded, vertical lift check	P6@.210	Ea	79.40	11.10	90.50
150 lb, threaded, swing, bronze disk	P6@.210	Ea	53.20	11.10	64.30
200 lb, threaded, swing, bronze disk	P6@.210	Ea	104.00	11.10	115.10
					
3/4" bronze check valves					
125 lb, threaded, swing	P6@.250	Ea	22.90	13.20	36.10
125 lb, soldered, swing	P6@.240	Ea	21.90	12.70	34.60
125 lb, threaded, swing, vertical check	P6@.250	Ea	109.00	13.20	122.20
150 lb, threaded, swing, bronze disk	P6@.250	Ea	66.50	13.20	79.70
200 lb, threaded, swing, bronze disk	P6@.250	Ea	124.00	13.20	137.20
1" bronze check valves					
125 lb, threaded, swing	P6@.300	Ea	30.40	15.90	46.30
125 lb, soldered, swing	P6@.290	Ea	29.30	15.30	44.60
125 lb, threaded, swing, vertical check	P6@.300	Ea	137.00	15.90	152.90
150 lb, threaded, swing, bronze disk	P6@.300	Ea	90.10	15.90	106.00
200 lb, threaded, swing, bronze disk	P6@.300	Ea	192.00	15.90	207.90
					
1-1/2" bronze check valves					
125 lb, threaded, swing	P6@.450	Ea	59.50	23.80	83.30
125 lb, soldered, swing	P6@.440	Ea	58.20	23.30	81.50
125 lb, threaded, swing, vertical check	P6@.450	Ea	229.00	23.80	252.80
150 lb, threaded, swing, swing, bronze disk	P6@.450	Ea	157.00	23.80	180.80
200 lb, threaded, swing, bronze disk	P6@.450	Ea	309.00	23.80	332.80
2" bronze check valves					
125 lb, threaded, swing	P6@.500	Ea	99.60	26.50	126.10
125 lb, soldered, swing	P6@.480	Ea	97.60	25.40	123.00
125 lb, threaded, vertical check	P6@.500	Ea	340.00	26.50	366.50
150 lb, threaded, swing, bronze disk	P6@.500	Ea	228.00	26.50	254.50
200 lb, threaded, swing, bronze disk	P6@.500	Ea	435.00	26.50	461.50
2-1/2" flanged iron body check valve					
Swing check, bronze trim, 125 psi steam	MI@.600	Ea	197.00	33.60	230.60
Swing check, iron trim, 125 psi steam	MI@.600	Ea	277.00	33.60	310.60
Swing check, bronze trim, 250 psi steam	MI@.750	Ea	603.00	42.00	645.00
3" flanged iron body check valve					
Swing check, bronze trim, 125 psi steam	MI@.750	Ea	240.00	42.00	282.00
Swing check, iron trim, 125 psi steam	MI@.750	Ea	381.00	42.00	423.00
Swing check, bronze trim, 250 psi steam	MI@1.25	Ea	749.00	69.90	818.90

22 Plumbing

	Craft@Hrs	Unit	Material	Labor	Total
4" flanged iron body check valve					
Swing check, bronze trim, 125 psi steam	Ml@1.35	Ea	386.00	75.50	461.50
Swing check, iron trim, 125 psi steam	Ml@1.35	Ea	630.00	75.50	705.50
Swing check, bronze trim, 250 psi steam	Ml@1.85	Ea	952.00	103.00	1,055.00
6" flanged iron body check valve					
Swing check, bronze trim, 125 psi steam	Ml@2.50	Ea	626.00	140.00	766.00
Swing check, iron trim, 125 psi steam	Ml@2.50	Ea	1,000.00	140.00	1,140.00
Swing check, bronze trim, 250 psi steam	Ml@3.00	Ea	1,780.00	168.00	1,948.00
8" flanged iron body check valve					
Swing check, bronze trim, 125 psi steam	Ml@3.00	Ea	1,160.00	168.00	1,328.00
Swing check, iron trim, 125 psi steam	Ml@3.00	Ea	1,820.00	168.00	1,988.00
10" flanged iron body check valve					
Swing check, bronze trim, 125 psi steam	Ml@4.00	Ea	2,360.00	224.00	2,584.00
Swing check, iron trim, 125 psi steam	Ml@4.00	Ea	3,790.00	224.00	4,014.00
12" flanged iron body check valve					
Swing check, bronze trim, 125 psi steam	Ml@4.50	Ea	3,110.00	252.00	3,362.00
Swing check, iron trim, 125 psi steam	Ml@4.50	Ea	4,940.00	252.00	5,192.00
Miscellaneous Valves and Regulators For water and steam applications, complies with American Society of Mechanical Engineers Standard B16, Manufacturers Standardization Society, Instrumentation Society of America standards.					
Angle valves, bronze, 150 lb, threaded, Teflon disk					
1/2" valve	P6@.210	Ea	77.50	11.10	88.60
3/4" valve	P6@.250	Ea	106.00	13.20	119.20
1" valve	P6@.300	Ea	152.00	15.90	167.90
1-1/4" valve	P6@.400	Ea	197.00	21.20	218.20
1-1/2" valve	P6@.450	Ea	384.00	23.80	407.80
Lavatory supply valve with hand wheel shutoff, flexible compression connection tube with length as					
1/2" angle or straight stops					
12" tube	P6@.294	Ea	28.70	15.60	44.30
15" tube	P6@.294	Ea	30.40	15.60	46.00
20" tube	P6@.473	Ea	36.10	25.00	61.10
Gas stops, lever handle					
1/2" stop	P6@.210	Ea	13.10	11.10	24.20
3/4" stop	P6@.250	Ea	17.40	13.20	30.60
1" stop	P6@.300	Ea	27.00	15.90	42.90
1-1/4" stop	P6@.450	Ea	40.50	23.80	64.30
1-1/2" stop	P6@.500	Ea	70.40	26.50	96.90
2" stop	P6@.750	Ea	110.00	39.70	149.70
Hose bibbs, threaded					
3/4", brass	P6@.350	Ea	6.47	18.50	24.97
Backflow preventers reduced pressure					
3/4", threaded, bronze, with 2 gate valves	P6@1.00	Ea	302.00	52.90	354.90
1", threaded, bronze, with 2 gate valves	P6@1.25	Ea	364.00	66.10	430.10
2", threaded, with 2 gate valves	P6@2.13	Ea	537.00	113.00	650.00
2-1/2", with 2 gate valves, flanged, iron body	Ml@2.00	Ea	2,740.00	112.00	2,852.00
3", with 2 gate valves, flanged, iron body	Ml@3.00	Ea	3,450.00	168.00	3,618.00
4", with 2 gate valves, flanged, iron body	Ml@4.50	Ea	4,120.00	252.00	4,372.00
6", without gate valves, flanged, iron body	Ml@8.00	Ea	6,750.00	448.00	7,198.00
6", with 2 gate valves, flanged, iron body	Ml@9.00	Ea	7,820.00	503.00	8,323.00
8", without gate valves, flanged, iron body	Ml@11.5	Ea	11,700.00	643.00	12,343.00
8", with 2 gate valves, flanged, iron body	Ml@12.5	Ea	17,100.00	699.00	17,799.00
Ball valves, bronze, 150 lb, threaded, Teflon seat					
1/2" valve	P6@.210	Ea	11.70	11.10	22.80
3/4" valve	P6@.250	Ea	17.40	13.20	30.60
1" valve	P6@.300	Ea	24.50	15.90	40.40

22 Plumbing

	Craft@Hrs	Unit	Material	Labor	Total
1-1/4" valve	P6@.400	Ea	42.40	21.20	63.60
1-1/2" valve	P6@.450	Ea	51.60	23.80	75.40
2" valve	P6@.500	Ea	69.60	26.50	96.10
2-1/2" valve	MI@.750	Ea	131.00	42.00	173.00
3" valve	MI@.950	Ea	181.00	53.10	234.10
Hose gate valves, with cap, 200 lb					
2-1/2", non-rising stem	P6@1.00	Ea	115.00	52.90	167.90
Pressure regulator valves, bronze, 300 lb threaded, 25 to 75 PSI, with "Y" strainer					
3/4" valve	P6@.250	Ea	158.00	13.20	171.20
1" valve	P6@.300	Ea	210.00	15.90	225.90
1-1/4" valve	P6@.400	Ea	325.00	21.20	346.20
1-1/2" valve	P6@.450	Ea	499.00	23.80	522.80
2" valve	P6@.500	Ea	632.00	26.50	658.50
2-1/2" valve	P6@.750	Ea	1,230.00	39.70	1,269.70
3" valve	P6@.950	Ea	1,430.00	50.30	1,480.30
Water control valves, threaded, 3-way with actuator					
2-1/2", CV 54	MI@.750	Ea	2,320.00	42.00	2,362.00
3", CV 80	MI@.950	Ea	2,760.00	53.10	2,813.10
4", CV 157	MI@1.30	Ea	5,290.00	72.70	5,362.70

Closed Cell Elastomeric Pipe Insulation Semi-split, non-self-sealing, thickness as shown, by nominal pipe diameter. R factor equals 3.58 at 220 degrees F. Make additional allowances for scaffolding if required. Also see fittings, flanges and valves at the end of this section. For more detailed coverage of pipe insulation, see *National Plumbing & HVAC Estimator*, <https://craftsman-book.com/national-estimator-cloud>.

1/4" pipe	P6@.039	LF	.23	2.06	2.29
3/8" pipe	P6@.039	LF	.24	2.06	2.30
1/2" pipe	P6@.039	LF	.18	2.06	2.24
3/4" pipe	P6@.039	LF	.22	2.06	2.28
1" pipe	P6@.042	LF	.36	2.22	2.58
1-1/4" pipe	P6@.042	LF	.41	2.22	2.63
1-1/2" pipe	P6@.042	LF	.59	2.22	2.81
2" pipe	P6@.046	LF	.82	2.43	3.25
2-1/2", 3/8" thick	P6@.056	LF	1.61	2.96	4.57
2-1/2", 1/2" thick	P6@.056	LF	2.17	2.96	5.13
2-1/2", 3/4" thick	P6@.056	LF	2.80	2.96	5.76
3", 3/8" thick	P6@.062	LF	1.68	3.28	4.96
3", 1/2" thick	P6@.062	LF	2.44	3.28	5.72
3", 3/4" thick	P6@.062	LF	3.17	3.28	6.45
4", 3/8" thick	P6@.068	LF	2.28	3.60	5.88
4", 1/2" thick	P6@.068	LF	2.87	3.60	6.47
4", 3/4" thick	P6@.068	LF	3.72	3.60	7.32
Add for self-sealing	—	%	75.0	—	—

Additional cost for insulating pipe fittings and flanges:

For each fitting or flange, add the cost of insulating 3 LF of pipe of the same size.

Additional cost for insulating valves: Valve body only. Add the cost of insulating 5 LF of pipe of the same size.

Body and bonnet or yoke valves. Add the cost of insulating 10 LF of pipe of the same size.

Fiberglass pipe insulation with AP-T Plus (all purpose self-sealing) jacket By nominal pipe diameter. R factor equals 2.56 at 300 degrees F. Add the cost of scaffolding, if required. Also see fittings, flanges and valves at the end of the previous section. Available in 3-foot lengths, price is per linear foot.

1/2" diameter pipe					
1/2" thick insulation	P6@.038	LF	2.59	2.01	4.60
1" thick insulation	P6@.038	LF	3.08	2.01	5.09
1-1/2" thick insulation	P6@.040	LF	6.18	2.12	8.30

22 Plumbing

	Craft@Hrs	Unit	Material	Labor	Total
3/4" diameter pipe					
1/2" thick insulation	P6@.038	LF	2.86	2.01	4.87
1" thick insulation	P6@.038	LF	3.52	2.01	5.53
1-1/2" thick insulation	P6@.040	LF	6.51	2.12	8.63
1" diameter pipe					
1/2" thick insulation	P6@.040	LF	3.01	2.12	5.13
1" thick insulation	P6@.040	LF	3.08	2.12	5.20
1-1/2" thick insulation	P6@.042	LF	6.84	2.22	9.06
1-1/4" diameter pipe					
1/2" thick insulation	P6@.040	LF	4.07	2.12	6.19
1" thick insulation	P6@.040	LF	4.11	2.12	6.23
1-1/2" thick insulation	P6@.042	LF	7.34	2.22	9.56
1-1/2" diameter pipe					
1/2" thick insulation	P6@.042	LF	3.56	2.22	5.78
1" thick insulation	P6@.042	LF	4.63	2.22	6.85
1-1/2" thick insulation	P6@.044	LF	7.92	2.33	10.25
2" diameter pipe					
1/2" thick insulation	P6@.044	LF	3.83	2.33	6.16
1" thick insulation	P6@.044	LF	5.27	2.33	7.60
1-1/2" thick insulation	P6@.046	LF	8.49	2.43	10.92

Meters, Gauges and Indicators

Water meters

Disc type, 1-1/2"	P6@1.00	Ea	222.00	52.90	274.90
Turbine type, 1-1/2"	P6@1.00	Ea	336.00	52.90	388.90
Displacement type, AWWA C7000, 1"	P6@.941	Ea	342.00	49.80	391.80
Displacement type, AWWA C7000, 1-1/2"	P6@1.23	Ea	1,190.00	65.10	1,255.10
Displacement type, AWWA C7000, 2"	P6@1.57	Ea	1,780.00	83.10	1,863.10
Curb stop and waste valve, 1"	P6@1.00	Ea	125.00	52.90	177.90

Thermoflow indicators, soldered

1-1/4" indicator	M5@2.01	Ea	458.00	105.00	563.00
2" indicator	M5@2.01	Ea	557.00	105.00	662.00
2-1/2" indicator	Ml@1.91	Ea	813.00	107.00	920.00

Cast steel steam meters, in-line, flanged, 300 PSI

1" pipe, threaded	M5@1.20	Ea	4,630.00	62.80	4,692.80
2" pipe	Ml@1.14	Ea	5,270.00	63.80	5,333.80
3" pipe	Ml@2.31	Ea	5,860.00	129.00	5,989.00
4" pipe	Ml@2.71	Ea	6,500.00	152.00	6,652.00

Cast steel by-pass steam meters, 2", by line pipe size

6" line	Ml@16.7	Ea	11,200.00	934.00	12,134.00
8" line	Ml@17.7	Ea	11,600.00	990.00	12,590.00
10" line	Ml@18.5	Ea	12,200.00	1,030.00	13,230.00
12" line	Ml@19.7	Ea	12,500.00	1,100.00	13,600.00
14" line	Ml@21.4	Ea	13,200.00	1,200.00	14,400.00
16" line	Ml@22.2	Ea	13,800.00	1,240.00	15,040.00
Add for steam meter pressure-compensated counter	—	Ea	1,910.00	—	1,910.00
Add for contactor used with dial counter	—	Ea	889.00	—	889.00
Add for wall or panel-mounted remote totalizer					
with contactor	—	Ea	1,470.00	—	1,470.00
Add for direct reading pressure gauge	M5@.250	Ea	108.00	13.10	121.10
Add for direct reading thermometer, stainless steel case, with trim, 2% accuracy					
3" dial	M5@.250	Ea	83.10	13.10	96.20

22 Plumbing

	Craft@Hrs	Unit	Material	Labor	Total
Plumbing Specialties					
Access doors for plumbing, primer coated steel 14 gauge door, 18 gauge frame, with cam lock, for masonry, drywall, tile, wall or ceiling. L&L Louvers					
Standard, wall or ceiling					
8" x 8"	SM@.500	Ea	31.70	30.60	62.30
12" x 12"	SM@.500	Ea	34.00	30.60	64.60
14" x 14"	SM@.500	Ea	40.10	30.60	70.70
16" x 16"	SM@.500	Ea	43.60	30.60	74.20
18" x 18"	SM@.500	Ea	49.90	30.60	80.50
22" x 22"	SM@.500	Ea	66.80	30.60	97.40
22" x 30"	SM@.500	Ea	85.30	30.60	115.90
24" x 24"	SM@.500	Ea	70.40	30.60	101.00
24" x 36"	SM@.500	Ea	102.00	30.60	132.60
30" x 30"	SM@.500	Ea	138.00	30.60	168.60
Add for cylinder lock	—	Ea	18.60	—	18.60
Add for louvers	—	%	150.0	—	—
Add for fire rating, non-insulated	—	%	400.0	—	—
Add for fire rating and insulated	—	%	500.0	—	—
Add for stainless steel, 304-2B	—	%	300.0	—	—
Cleanouts For drainage piping. A cleanout may be required: at the end of each waste line, or where a main building drain exits the building, or at regular 100' intervals for straight runs longer than 100', or at the base of soil or waste stacks, or where a 90-degree change in direction of a main building drain takes place. Consult your plumbing code for the regulations that apply to your area.					
Finished grade end cleanouts (Malcolm) with Neo-Loc & Dura-Coated cast iron body					
2" pipe, 4-1/8" round top	P6@.500	Ea	116.00	26.50	142.50
3" pipe, 5-1/8" round top	P6@.500	Ea	156.00	26.50	182.50
4" pipe, 6-1/8" round top	P6@.500	Ea	166.00	26.50	192.50
Cast iron in-line cleanouts (Barrett). Make additional allowances for access doors					
2" pipe	P6@.350	Ea	43.50	18.50	62.00
4" pipe	P6@.400	Ea	81.50	21.20	102.70
6" pipe	P6@.400	Ea	287.00	21.20	308.20
Cleanout access cover accessories					
Round polished bronze cover	—	Ea	23.40	—	23.40
Square chrome plated cover	—	Ea	213.00	—	213.00
Square bronze hinged cover box	—	Ea	152.00	—	152.00
Floor drains , body and grate only, add rough-in					
3" x 2" plastic grate and body	P6@.250	Ea	20.90	13.20	34.10
5" x 3" plastic grate and body	P6@.250	Ea	29.50	13.20	42.70
3" x 2" cast iron body, nickel-bronze grate	P6@.500	Ea	72.90	26.50	99.40
5" x 3" cast iron body, nickel-bronze grate	P6@.500	Ea	83.60	26.50	110.10
6" x 4" cast iron body, nickel-bronze grate	P6@.500	Ea	97.00	26.50	123.50
Add for a sediment bucket	—	Ea	14.00	—	14.00
Add for plastic backwater valve	—	Ea	54.40	—	54.40
Add for cast iron backwater valve	—	Ea	408.00	—	408.00
Add for trap seal primer fitting	—	Ea	9.88	—	9.88
Drain, general use, medium duty, PVC plastic, 3" or 4" pipe					
3" x 4", stainless steel strainer	P6@1.16	Ea	12.90	61.40	74.30
3" x 4", brass strainer	P6@1.32	Ea	31.70	69.80	101.50
4" with 5" brass strainer & spigot outlet	P6@1.55	Ea	59.30	82.00	141.30
Roof drains, cast iron mushroom strainer, bottom outlet					
2" to 4" drain	P6@1.75	Ea	306.00	92.60	398.60
5" or 6" drain	P6@1.98	Ea	428.00	105.00	533.00
8" drain	P6@2.36	Ea	563.00	125.00	688.00

22 Plumbing

	Craft@Hrs	Unit	Material	Labor	Total
Roof (jack) flashing, round					
4" jack	SM@.311	Ea	10.90	19.10	30.00
6" jack	SM@.416	Ea	11.80	25.50	37.30
8" jack	SM@.516	Ea	16.50	31.60	48.10
Plumbing Equipment Valves, supports, vents, gas or electric hookup and related equipment are not included except as noted.					
Water heaters, commercial, gas fired 3-year limited warranty. Set in place only. Make additional allowances for pipe, circulating pump, gas and flue connections.					
Medium duty					
75 gallon, 75 MBtu, low NOx	P6@2.00	Ea	2,060.00	106.00	2,166.00
75 gallon, 75 MBtu, ultra low NOx	P6@2.25	Ea	2,050.00	119.00	2,169.00
98 gallon, 75 MBtu, ultra low NOx	P6@2.50	Ea	2,850.00	132.00	2,982.00
100 gallon, 80 MBtu,	P6@2.50	Ea	2,670.00	132.00	2,802.00
Heavy duty					
37 gallon, 200 MBtu, low NOx	P6@2.00	Ea	6,740.00	106.00	6,846.00
65 gallon, 360 MBtu	P6@2.00	Ea	7,940.00	106.00	8,046.00
65 gallon, 400 MBtu	P6@2.00	Ea	7,830.00	106.00	7,936.00
72 gallon, 300 MBtu	P6@2.25	Ea	6,380.00	119.00	6,499.00
80 gallon, 130 MBtu, ultra-low NOx	P6@2.25	Ea	5,770.00	119.00	5,889.00
80 gallon, 160 MBtu, ultra-low NOx	P6@2.25	Ea	7,640.00	119.00	7,759.00
80 gallon, 200 MBtu, ultra-low NOx	P6@2.25	Ea	6,520.00	119.00	6,639.00
80 gallon, 300 MBtu, ultra-low NOx	P6@2.25	Ea	9,370.00	119.00	9,489.00
82 gallon, 156 MBtu, ultra-low NOx	P6@2.25	Ea	5,860.00	119.00	5,979.00
85 gallon, 300 MBtu	P6@2.25	Ea	7,040.00	119.00	7,159.00
100 gallon, 200 MBtu, ultra-low NOx	P6@2.50	Ea	5,000.00	132.00	5,132.00
100 gallon, 250 MBtu	P6@2.50	Ea	6,090.00	132.00	6,222.00
100 gallon, 270 MBtu	P6@2.50	Ea	6,210.00	132.00	6,342.00
100 gallon, 400 MBtu	P6@2.50	Ea	9,310.00	132.00	9,442.00
100 gallon, 400 MBtu, low NOx	P6@2.50	Ea	8,990.00	132.00	9,122.00
Add for ASME rating	—	%	10.0	—	—
Add for power vent kit	P6@2.00	Ea	854.00	106.00	960.00
Add for duplex equal flow manifold kit	—	Ea	586.00	—	586.00
Add for triplex equal flow manifold kit	—	Ea	1,160.00	—	1,160.00
Add for propane fired units, any of above	—	Ea	150.00	—	150.00
Commercial tankless condensing water heater, 9.5 GPM					
Indoor	P6@2.50	Ea	1,630.00	132.00	1,762.00
Outdoor	P6@4.15	Ea	1,670.00	220.00	1,890.00
Water heaters, commercial, electric 208/240 volts, with surface-mounted thermostat, Rheem. Set in place only. Make additional allowances for pipe, circulating pump, and electrical connections.					
85 gallons, 12 kW, light duty, non-metallic	P6@1.75	Ea	3,560.00	92.60	3,652.60
105 gallons, 12 kW, light duty, non-metallic	P6@2.00	Ea	4,820.00	106.00	4,926.00
85 gallons, 18 kW, 3-ph, heavy duty, immersion stat	P6@1.75	Ea	6,310.00	92.60	6,402.60
120 gallons, 24 kW, 3-ph, heavy duty	P6@3.00	Ea	7,350.00	159.00	7,509.00
120 gallons, 24 kW, 3-ph, heavy duty, immersion stat	P6@3.00	Ea	8,560.00	159.00	8,719.00
Water heater stands Installed at same time as water heater. Raises flame elements 18" off floor. Secures to wall with seismic clips.					
80 gallon capacity	P6@.250	Ea	48.60	13.20	61.80
100 gallon capacity	P6@.250	Ea	90.80	13.20	104.00
Fully enclosed, 80 gallon capacity	P6@.500	Ea	141.00	26.50	167.50
Water heater safety pans					
1" side outlet drain, aluminum, installed at same time as water heater					
22" diameter	—	Ea	18.20	—	18.20
26" diameter	—	Ea	20.30	—	20.30
30" diameter	—	Ea	30.70	—	30.70
Tankless water heater drain pan	—	Ea	65.00	—	65.00
Subtract for polyethylene pan	—	%	-50.0	—	—

22 Plumbing

	Craft@Hrs	Unit	Material	Labor	Total
1" bottom outlet drain, 16 gauge steel, installed at same time as water heater. Piping not included.					
16" diameter	—	Ea	18.70	—	18.70
19" diameter	—	Ea	23.80	—	23.80
22" diameter	—	Ea	28.40	—	28.40
24" diameter	—	Ea	31.50	—	31.50
26-1/2" diameter	—	Ea	34.40	—	34.40
Water heater earthquake restraints State approved, installed at the same time as water heater					
Up to 52 gal heater, double strap	P6@.250	Ea	20.20	13.20	33.40
Up to 100 gal heater, double strap	P6@.250	Ea	22.30	13.20	35.50
Freestanding restraint system – 75 gal capacity	P6@.250	Ea	223.00	13.20	236.20
Freestanding restraint system – 100 gal capacity	P6@.250	Ea	241.00	13.20	254.20
Wall-mount platform with restraints – 75 gal capacity	P6@.500	Ea	214.00	26.50	240.50
Wall-mount platform with restraints – 100 gal capacity	P6@.500	Ea	237.00	26.50	263.50
Water heater leak detection system Auto shutoff when leak detected. Manual override. 110VAC with battery backup					
FloodStop leak detection system	P6@.250	Ea	142.00	13.20	155.20
Water heater connection assembly Includes typical pipe, fittings, valves, gages, and hangers					
Copper pipe connection, 3/4" supply	P6@2.25	Ea	245.00	119.00	364.00
Copper pipe connection, 1" supply	P6@2.75	Ea	435.00	146.00	581.00
Copper pipe connection, 1-1/4" supply	P6@3.50	Ea	536.00	185.00	721.00
Copper pipe connection, 1-1/2" supply	P6@3.75	Ea	552.00	198.00	750.00
Copper pipe connection, 2" supply	P6@4.50	Ea	591.00	238.00	829.00
Copper pipe connection, 2-1/2" supply	P6@5.75	Ea	1,230.00	304.00	1,534.00
Copper pipe connection, 3" supply	P6@6.50	Ea	1,900.00	344.00	2,244.00
Carbon steel gas pipe connection, 3/4"	P6@1.40	Ea	119.00	74.10	193.10
Carbon steel gas pipe connection, 1"	P6@1.50	Ea	154.00	79.40	233.40
Carbon steel gas pipe connection, 1-1/2"	P6@2.00	Ea	227.00	106.00	333.00
Double wall vent pipe connection, 4"	P6@1.40	Ea	135.00	74.10	209.10
Instantaneous water heaters, electric Maximum operating pressure of 150 PSI. Includes plumbing hookup only. Add for electrical work. 1/2" compression fittings used except where noted.					
120/208/240 volt single point for point-of-use handwashing. 33-degree F temperature rise at 1/2 GPM. Includes 3/8" compression fittings.					
2.4/3.0 kW unit	P6@1.00	Ea	703.00	52.90	755.90
208/240 volt flow controlled for kitchen, bar sink and dual lavatory sinks. 38-degree F temperature rise at 1.0 GPM.					
8.3 kW unit	P6@1.00	Ea	489.00	52.90	541.90
240/277 volt thermostatic for applications where accurate temperature control is required. May be used in combination with other water heating units. 41-degree F temperature rise at 1.0 GPM.					
6.0 kW unit	P6@1.00	Ea	627.00	52.90	679.90
240 volt twin heating module for residential showers, mop sinks, industrial processes, campgrounds and resort cabins. May be used in combination with other water heating units. 51-degree F temperature rise at 2.0 GPM.					
15.0 kW unit	P6@1.00	Ea	912.00	52.90	964.90
277 volt high capacity instantaneous water heater. May be used in combination with other water heating units. 35-degree F temperature rise at 3.5 GPM.					
18.0 kW unit	P6@1.00	Ea	2,010.00	52.90	2,062.90
240 volt high purity for microchip manufacturing, pharmaceutical production, ultrasonic cleaning and batch chemical mixing. Maintains water purity up to 18 MEG OHM quality. 38-degree F temperature rise at 1.0 GPM.					
5.5 kW unit	P6@1.00	Ea	1,190.00	52.90	1,242.90

22 Plumbing

	Craft@Hrs	Unit	Material	Labor	Total
Solar Water Heating Systems					
Solar collector panels, no piping included					
Typical 24 SF panel	P6@.747	Ea	485.00	39.50	524.50
Supports for solar panels, per panel	P6@2.25	Ea	51.80	119.00	170.80
Control panel for solar heating system	P6@1.56	Ea	180.00	82.50	262.50
Solar collector system pumps, no wiring or piping included					
5.4 GPM, 7.9' head	P6@1.89	Ea	284.00	100.00	384.00
10.5 GPM, 11.6' head or 21.6 GPM, 8.5' head	P6@2.25	Ea	515.00	119.00	634.00
12.6 GPM, 20.5' head or 22.5 GPM, 13.3' head	P6@3.26	Ea	791.00	172.00	963.00
46.5 GPM, 13.7' head	P6@4.59	Ea	119.00	243.00	362.00
60.9 GPM, 21.0' head	P6@5.25	Ea	1,340.00	278.00	1,618.00
Solar hot water storage tanks, no piping and no pad included					
40 gallon, horizontal	P6@1.12	Ea	355.00	59.30	414.30
110 gallon, horizontal	P6@3.54	Ea	1,440.00	187.00	1,627.00
180 gallon, vertical	P6@5.43	Ea	2,260.00	287.00	2,547.00
650 gallon, horizontal	P6@5.84	Ea	3,460.00	309.00	3,769.00
1,250 gallon, horizontal	P6@5.84	Ea	5,120.00	309.00	5,429.00
1,500 gallon, vertical	P6@11.4	Ea	8,140.00	603.00	8,743.00
2,200 gallon, horizontal	P6@17.1	Ea	7,390.00	905.00	8,295.00
2,700 gallon, vertical	P6@14.9	Ea	8,390.00	788.00	9,178.00
Grease interceptors					
2" cast iron, 4 GPM, 8 lb capacity	P6@4.00	Ea	819.00	212.00	1,031.00
2" cast iron, 10 GPM, 20 lb capacity	P6@5.00	Ea	1,330.00	265.00	1,595.00
2" steel, 15 GPM, 30 lb capacity	P6@7.00	Ea	1,970.00	370.00	2,340.00
3" steel, 20 GPM, 40 lb capacity	P6@8.00	Ea	2,430.00	423.00	2,853.00
4" steel, 750 lb capacity, 48" x 84" x 60"	P6@16.0	Ea	7,380.00	838.00	7,458.00
4" steel, 1,250 lb capacity, 60" x 102" x 60"	P6@16.0	Ea	8,650.00	838.00	8,598.00
Hair interceptors					
1-1/2" cast iron	P6@.650	Ea	277.00	34.40	311.40
1-1/2" nickel bronze	P6@.750	Ea	389.00	39.70	428.70
Sewage ejector packaged systems with vertical pumps, float switch controls, poly tank, cover and fittings, no electrical work or pipe connections included.					
Simplex sewage ejector systems (single pump)					
1/2 HP, 2" line, 20" x 30" tank	P6@4.75	Ea	730.00	251.00	981.00
3/4 HP, 2" line, 24" x 36" tank	P6@4.75	Ea	1,840.00	251.00	2,091.00
1 HP, 3" line, 24" x 36" tank	P6@6.00	Ea	2,150.00	317.00	2,467.00
Duplex sewage ejector systems (two pumps), alternator not included					
1/2 HP, 2" line, 30" x 36" tank	P6@6.50	Ea	2,830.00	344.00	3,174.00
3/4 HP, 2" line, 30" x 36" tank	P6@6.50	Ea	3,680.00	344.00	4,024.00
1 HP, 3" line, 30" x 36" tank	P6@8.00	Ea	4,120.00	423.00	4,543.00
Duplex pump controls (alternator)	—	Ea	1,510.00	—	1,510.00
Sump pumps With float switch, no electrical work included					
Submersible type					
1/4 HP, 1-1/2" outlet, ABS plastic	P6@2.00	Ea	148.00	106.00	254.00
1/3 HP, 1-1/4" outlet, cast iron	P6@2.00	Ea	217.00	106.00	323.00
1/3 HP, 1-1/4" outlet, ABS plastic	P6@2.00	Ea	179.00	106.00	285.00
Upright type					
1/3 HP, 1-1/4" outlet, cast iron	P6@2.00	Ea	173.00	106.00	279.00
1/3 HP, 1-1/2" outlet, ABS plastic	P6@2.00	Ea	127.00	106.00	233.00

22 Plumbing

	Craft@Hrs	Unit	Material	Labor	Total
Hot water storage tanks Insulated, floor mounted, includes pipe connection					
80 gallons	P6@4.00	Ea	764.00	212.00	976.00
120 gallons	P6@4.50	Ea	1,170.00	238.00	1,408.00
200 gallons	P6@5.25	Ea	3,150.00	278.00	3,428.00
980 gallons	P6@20.0	Ea	10,800.00	1,060.00	11,860.00
1,230 gallons	P6@22.0	Ea	12,800.00	1,160.00	13,960.00
1,615 gallons	P6@26.0	Ea	17,900.00	1,380.00	19,280.00
Septic tanks Includes typical excavation and piping					
500 gallons, polyethylene	U2@15.2	Ea	917.00	747.00	1,664.00
1,000 gallons, fiberglass	U2@16.1	Ea	1,320.00	791.00	2,111.00
2,000 gallons, concrete	U2@17.0	Ea	1,720.00	836.00	2,556.00
5,000 gallons, concrete	U2@22.3	Ea	6,390.00	1,100.00	7,490.00
Water softeners Automatic two tank unit, 3/4" valve					
1.0 CF, 30,000 grain capacity	P6@3.59	Ea	398.00	190.00	588.00
2.0 CF, 60,000 grain capacity	P6@3.59	Ea	520.00	190.00	710.00
Water filters In-line, filters for taste, odor, chlorine and sediment to 20 microns, with by-pass assembly. Includes pipe connection.					
Housing, by-pass and carbon filter, complete	P6@2.50	Ea	228.00	132.00	360.00
Water filter housing only	P6@1.00	Ea	57.30	52.90	110.20
By-pass assembly only, 3/4" copper	P6@1.25	Ea	124.00	66.10	190.10
Carbon core cartridge, 20 microns	P6@.250	Ea	28.50	13.20	41.70
Ceramic disinfection and carbon cartridge	P6@.250	Ea	76.30	13.20	89.50
Lead, chlorine, taste and odor cartridge	P6@.250	Ea	57.30	13.20	70.50
Water sterilizers Ultraviolet, point-of-use water. Add the cost of electrical and pipe connections. In gallons per minute (GPM) of rated capacity. 2 GPM and larger units include light-emitting diode (LED).					
1/2 GPM point of use filter, 1/2" connection	P6@2.00	Ea	284.00	106.00	390.00
3/4 GPM point of use filter, 1/2" connection	P6@2.00	Ea	303.00	106.00	409.00
2 GPM, 1/2" connection	P6@2.50	Ea	336.00	132.00	468.00
2 GPM, with alarm, 1/2" connection	P6@2.50	Ea	435.00	132.00	567.00
2 GPM, with alarm and monitor, 1/2" connection	P6@3.00	Ea	647.00	159.00	806.00
5 GPM, 3/4" connection	P6@2.50	Ea	614.00	132.00	746.00
5 GPM, with alarm, 3/4" connection	P6@2.50	Ea	700.00	132.00	832.00
5 GPM, with alarm and monitor, 3/4" connection	P6@3.00	Ea	796.00	159.00	955.00
8 GPM, with alarm, 3/4" connection	P6@2.50	Ea	647.00	132.00	779.00
8 GPM, with alarm and monitor, 3/4" connection	P6@3.00	Ea	865.00	159.00	1,024.00
12 GPM, with alarm, 3/4" connection	P6@2.50	Ea	825.00	132.00	957.00
12 GPM, with alarm and monitor, 3/4" connection	P6@3.00	Ea	1,000.00	159.00	1,159.00
Reverse osmosis water filters Economy system. Add the cost of electrical and pipe connections. In gallons per day of rated capacity.					
12 gallons per day	P6@3.50	Ea	314.00	185.00	499.00
16 gallons per day	P6@3.50	Ea	336.00	185.00	521.00
30 gallons per day	P6@3.50	Ea	473.00	185.00	658.00
60 gallons per day	P6@3.50	Ea	524.00	185.00	709.00
100 gallons per day	P6@3.50	Ea	797.00	185.00	982.00

22 Plumbing

Craft@Hrs Unit Material Labor Total

Rough-in Plumbing Assemblies Includes rough-ins for commercial, industrial and residential buildings. This section shows costs for typical rough-ins of drain, waste and vent (DWV) and water supply piping using either plastic or metal pipe and fittings. Plastic ABS or PVC DWV pipe can be combined with plastic "poly b" supply pipe for a complete residential rough-in assembly. Cast iron or copper drainage DWV pipe can be combined with copper supply pipe for a complete commercial rough-in assembly. (Check local plumbing and building codes to determine acceptable materials for above and below grade installations in your area.) Detailed estimates of the piping requirements for each type plumbing fixture rough-in were made using the Uniform Plumbing Code as a guideline. For scheduling purposes, estimate that a plumber and an apprentice can install rough-in piping for 3 to 4 plumbing fixtures in an 8-hour day. The same plumber and apprentice will install, connect and test 3 to 4 fixtures a day. When roughing-in less than 4 fixtures in a building, increase the rough-in cost 25% for each fixture less than 4. Add the cost of the fixture and final connection assembly (as shown in Fixtures and Final Connection Assemblies) to the rough-in assembly cost. Rule of Thumb: Use plastic drainage and supply pipe in economy residential applications. Use plastic drainage and copper supply in quality residential applications. Use cast iron or copper DWV drainage and copper supply pipe in quality commercial applications. In some jurisdictions, plastic drainage pipe is allowed below grade for commercial applications only. In residential applications, plastic drainage pipe may be allowed in above and below grade applications. The difference is the liability of the owner to the patrons of a public building vs. the liability of the owner of a private residence in case of fire. ABS pipe releases toxic gases when it burns.

Water closet rough-in

Floor mounted, tank type, rough-in includes 7' of 3", 8' of 1-1/2" DWV pipe and 8' of 1/2" supply pipe with typical fittings, hangers, and strapping

Plastic DWV and PEX supply rough-in	P6@1.90	Ea	29.00	101.00	130.00
Plastic DWV and copper supply rough-in	P6@2.00	Ea	37.00	106.00	143.00
Cast iron and copper supply rough-in	P6@2.25	Ea	130.00	119.00	249.00
Copper DWV and copper supply rough-in	P6@2.25	Ea	216.00	119.00	335.00

Floor mounted flush valve type, rough-in includes 7' of 3", 8' of 1-1/2" DWV pipe and 8' of 1" supply pipe with typical fittings, hangers, and strapping

Plastic DWV and PVC schedule 40 supply rough-in	P6@1.90	Ea	30.90	101.00	131.90
Plastic DWV and copper supply rough-in	P6@2.00	Ea	59.90	106.00	165.90
Cast iron and copper supply rough-in	P6@2.25	Ea	153.00	119.00	272.00
Copper DWV and copper supply rough-in	P6@2.25	Ea	216.00	119.00	335.00

Wall hung, tank type, rough-in includes 5' of 4", 8' of 1-1/2" DWV pipe and 8' of 1/2" supply pipe with typical fittings, hangers, and strapping

Plastic DWV and PEX supply rough-in	P6@1.80	Ea	29.30	95.20	124.50
Plastic DWV and copper supply rough-in	P6@1.90	Ea	37.20	101.00	138.20
Cast iron and copper supply rough-in	P6@2.35	Ea	126.00	124.00	250.00
Copper DWV and copper supply rough-in	P6@2.35	Ea	243.00	124.00	367.00
Add for fixture carrier	P6@.750	Ea	338.00	39.70	377.70

Wall hung flush valve type, rough-in includes 5' of 4", 6' of 1-1/2" DWV pipe and 8' of 1" supply pipe with typical fittings, hangers, and strapping

Plastic DWV and PVC schedule 40 supply rough-in	P6@1.70	Ea	29.40	89.90	119.30
Plastic DWV and copper supply rough-in	P6@1.00	Ea	58.40	52.90	111.30
Cast iron and copper supply rough-in	P6@1.95	Ea	135.00	103.00	238.00
Copper DWV and copper supply rough-in	P6@1.95	Ea	227.00	103.00	330.00
Add for fixture carrier	P6@.750	Ea	306.00	39.70	345.70

Urinal rough-in

Wall-hung urinal, rough-in includes 15' of DWV pipe and 8' of supply pipe with typical fittings, hangers and strapping

Plastic DWV and supply rough-in	P6@2.00	Ea	18.00	106.00	124.00
Plastic DWV and copper supply rough-in	P6@2.10	Ea	33.90	111.00	144.90
Copper DWV and copper supply rough-in	P6@2.35	Ea	147.00	124.00	271.00
Add for fixture carrier	P6@.850	Ea	243.00	45.00	288.00

22 Plumbing

	Craft@Hrs	Unit	Material	Labor	Total
Floor-mounted urinal, rough-in includes 15' of DWV pipe and 8' of supply pipe with typical fittings, hangers and strapping					
Plastic DWV and supply rough-in	P6@2.15	Ea	18.00	114.00	132.00
Plastic DWV and copper supply rough-in	P6@2.25	Ea	33.90	119.00	152.90
Copper DWV and copper supply rough-in	P6@2.50	Ea	147.00	132.00	279.00
Lavatory rough-in					
Lavatory, rough-in includes 15' of 1-1/2" DWV pipe and 15' of 1/2" supply pipe with typical fittings, hangers and strapping					
Plastic DWV and PEX supply rough-in	P6@1.70	Ea	22.00	89.90	111.90
Plastic DWV and copper supply rough-in	P6@1.75	Ea	36.90	92.60	129.50
Copper DWV and copper supply rough-in	P6@1.90	Ea	150.00	101.00	251.00
Add for carrier	P6@.750	Ea	242.00	39.70	281.70
Bathtub and shower Rough-in includes 15' of 1-1/2" DWV pipe and 15' of 1/2" supply pipe with typical fittings, hangers, and strapping					
Plastic DWV and PEX supply rough-in	P6@1.95	Ea	22.00	103.00	125.00
Plastic DWV and copper supply rough-in	P6@2.10	Ea	36.90	111.00	147.90
Copper DWV and copper supply rough-in	P6@2.35	Ea	150.00	124.00	274.00
Kitchen sink Rough-in includes 15' of 1-1/2" DWV pipe and 15' of 1/2" supply pipe with typical, fittings, hangers and strapping					
Plastic DWV and PEX supply rough-in	P6@1.70	Ea	22.00	89.90	111.90
Plastic DWV and copper supply rough-in	P6@1.75	Ea	36.90	92.60	129.50
Copper DWV and copper supply rough-in	P6@1.90	Ea	150.00	101.00	251.00
Drinking fountain and water cooler Rough-in includes 15' of 1-1/2" DWV pipe and 10' of 1/2" supply pipe with typical, fittings, strapping and hangers					
Plastic DWV and PEX supply rough-in	P6@1.80	Ea	19.20	95.20	114.40
Plastic DWV and copper supply rough-in	P6@2.00	Ea	29.10	106.00	135.10
Copper DWV and copper supply rough-in	P6@2.20	Ea	142.00	116.00	258.00
Wash fountain Rough-in includes 20' of 1-1/2" DWV pipe and 20' of 1/2" supply pipe with typical fittings, hangers and strapping					
Plastic DWV and supply rough-in	P6@1.90	Ea	29.30	101.00	130.30
Plastic DWV and copper supply rough-in	P6@2.00	Ea	49.20	106.00	155.20
Copper DWV and copper supply rough-in	P6@2.10	Ea	199.00	111.00	310.00
Service sink Rough-in includes 15' of DWV pipe and 15' of supply pipe with typical fittings, hangers, and strapping					
Wall-hung slop sink					
Plastic DWV and supply rough-in	P6@2.25	Ea	22.00	119.00	141.00
Plastic DWV and copper supply rough-in	P6@2.35	Ea	36.90	124.00	160.90
Cast iron DWV and copper supply rough-in	P6@2.45	Ea	150.00	130.00	280.00
Floor-mounted mop sink					
Plastic DWV and supply rough-in	P6@2.35	Ea	22.00	124.00	146.00
Plastic DWV and copper supply rough-in	P6@2.45	Ea	36.90	130.00	166.90
Cast iron DWV and copper supply rough-in	P6@2.60	Ea	150.00	138.00	288.00
Emergency drench shower and eye wash station Rough-in includes a valved water supply with 15' of supply pipe, typical fittings and hangers. Add the cost of a floor drain if required. See section below.					
3/4" PVC schedule 40	P6@1.25	Ea	31.40	66.10	97.50
3/4" Copper pipe	P6@1.50	Ea	61.00	79.40	140.40
Surgeons' scrub sink Rough-in includes 7' of 2" and 8' of 1-1/2" DWV pipe and 15' of 3/4" supply pipe with typical fittings and hangers					
Plastic DWV and supply rough-in	P6@2.25	Ea	24.40	119.00	143.40
Plastic DWV and copper supply rough-in	P6@2.35	Ea	54.00	124.00	178.00
Cast iron DWV and copper supply rough-in	P6@2.75	Ea	146.00	146.00	292.00

22 Plumbing

	Craft@Hrs	Unit	Material	Labor	Total
Floor sink, floor drain Rough-in includes 15' of drain and 15' of vent pipe, P-trap, typical fittings and hangers. Does not include the actual floor drain unit.					
2" plastic DWV rough-in	P6@1.50	Ea	43.60	79.40	123.00
3" plastic DWV rough-in	P6@1.75	Ea	94.50	92.60	187.10
2" cast iron DWV rough-in	P6@2.00	Ea	229.00	106.00	335.00
3" cast iron DWV rough-in	P6@2.50	Ea	298.00	132.00	430.00
4" cast iron DWV rough-in	P6@2.50	Ea	386.00	132.00	518.00
Fixtures and final connection assemblies					
Fixture costs are based on good to better quality white fixtures of standard dimensions and include all trim and valves required by code. Add 30% for colored fixtures.					
Water closets					
Floor-mounted, tank type, elongated vitreous china bowl					
Water closet, trim and valves (add rough-in)	P6@2.10	Ea	277.00	111.00	388.00
Deduct for round bowl	—	Ea	-47.50	—	-47.50
Floor-mounted flush valve type, elongated vitreous china bowl					
Water closet, trim and valves (add rough-in)	P6@2.60	Ea	359.00	138.00	497.00
Floor-mounted flush valve type, elongated vitreous china bowl, meets ADA requirements (18" high)					
Water closet, trim and valves (add rough-in)	P6@2.60	Ea	425.00	138.00	563.00
Wall-hung, tank type, elongated vitreous china bowl, cast iron carrier					
Water closet, trim and valves (add rough-in)	P6@3.00	Ea	809.00	159.00	968.00
Deduct for round bowl	—	Ea	-93.60	—	-93.60
Wall-hung flush valve type elongated vitreous china bowl, cast iron carrier					
Water closet, trim and valves (add rough-in)	P6@3.55	Ea	573.00	188.00	761.00
Add for bed pan cleanser (flush valve and rim lugs)	P6@1.50	Ea	249.00	79.40	328.40
Urinals					
Wall-hung urinal, vitreous china, washout flush action, 3/4" top spud with hand operated flush valve/vacuum breaker					
Urinal, trim and valves (add rough-in)	P6@2.35	Ea	465.00	124.00	589.00
Add for fixture carrier	P6@1.25	Ea	132.00	66.10	198.10
Floor-mounted urinal, 18" wide, sloping front vitreous china, washout flush action, 3/4" top spud with hand operated flush valve/vacuum breaker					
Urinal, trim and valves (add rough-in)	P6@5.25	Ea	1,110.00	278.00	1,388.00
Water-conserving urinals, faucets and flush valves					
Wall-mounted urinal, ABS-structural plastic. Fit between studs framed at 16" on center.					
Add the cost of wall finishing and rough-in plumbing					
10 oz water per flush	P6@1.50	Ea	361.00	79.40	440.40
Battery-powered sensor faucet, 6 volt DC. Continuous discharge up to 10 seconds. Less than one quart per cycle.					
Standard spout	P6@1.50	Ea	481.00	79.40	560.40
Gooseneck spout	P6@1.50	Ea	527.00	79.40	606.40
AC-powered sensor faucet, 12 volt. Continuous discharge up to 10 seconds. Less than one quart per cycle					
Standard spout	P6@1.50	Ea	481.00	79.40	560.40
Gooseneck spout	P6@1.50	Ea	527.00	79.40	606.40
Battery-powered sensor flush valves, 6 volt DC, exposed. Light flushing after brief use and full flushing after extended use. Includes rough fittings					
Urinal flush valve	P6@2.00	Ea	432.00	106.00	538.00
Toilet flush valve, 1.6 or 3.5 gallons	P6@2.00	Ea	474.00	106.00	580.00

22 Plumbing

	Craft@Hrs	Unit	Material	Labor	Total
AC-powered sensor flush valves, 24 volt. Light flushing after brief use and full flushing after extended use. Includes rough fittings					
Urinal flush valve, exposed	P6@2.00	Ea	551.00	106.00	657.00
Urinal flush valve, concealed	P6@2.00	Ea	563.00	106.00	669.00
Toilet flush valve	P6@2.00	Ea	597.00	106.00	703.00
Lavatories					
Wall-hung vitreous china lavatory with single handle faucet and pop-up waste					
Lavatory, trim and valves (add rough-in)	P6@2.50	Ea	473.00	132.00	605.00
Add for wheelchair type (ADA standards)	—	Ea	217.00	—	217.00
Countertop-mounted vitreous china lavatory with single handle water and pop-up waste					
Lavatory, trim and valves (add rough-in)	P6@2.00	Ea	354.00	106.00	460.00
Countertop-mounted enameled steel lavatory with single handle water faucet and pop-up waste					
Lavatory, trim and valves (add rough-in)	P6@2.00	Ea	298.00	106.00	404.00
Bathtubs and Showers					
Recessed enameled steel tub with shower					
Tub, trim and valves (add rough-in)	P6@2.50	Ea	382.00	132.00	514.00
Recessed enameled cast iron tub with shower					
Tub, trim and valves (add rough-in)	P6@4.50	Ea	651.00	238.00	889.00
Acrylic one-piece tub and shower enclosure					
Enclosure, trim and valves (add rough-in)	P6@4.75	Ea	436.00	251.00	687.00
Acrylic three-piece tub and shower enclosure (renovation)					
Enclosure, trim and valves (add rough-in)	P6@5.75	Ea	1,270.00	304.00	1,574.00
Fiberglass one-piece tub and shower enclosure					
Enclosure, trim and valves (add rough-in)	P6@4.75	Ea	700.00	251.00	951.00
Fiberglass three-piece tub and shower enclosure					
Enclosure, trim and valves (add rough-in)	P6@5.75	Ea	1,130.00	304.00	1,434.00
Acrylic one-piece shower stall					
Shower stall, trim and valves (add rough-in)	P6@3.50	Ea	990.00	185.00	1,175.00
Add for larger stall	—	Ea	191.00	—	191.00
Acrylic three-piece shower stall (renovation)					
Shower stall, trim and valves (add rough-in)	P6@4.25	Ea	1,390.00	225.00	1,615.00
Add for larger stall	—	Ea	191.00	—	191.00
Fiberglass one-piece shower stall					
Shower stall, trim and valves (add rough-in)	P6@3.50	Ea	649.00	185.00	834.00
Add for larger stall	—	Ea	150.00	—	150.00
Add for corner entry	—	Ea	112.00	—	112.00
Fiberglass three-piece shower stall (renovation)					
Shower stall, trim and valves (add rough-in)	P6@4.25	Ea	833.00	225.00	1,058.00
Add for larger stall	—	Ea	207.00	—	207.00
Add for corner entry	—	Ea	152.00	—	152.00
Acrylic shower base					
Base, trim and valves (add rough-in)	P6@2.50	Ea	408.00	132.00	540.00
Add for larger base	—	Ea	21.50	—	21.50
Add for corner entry	—	Ea	21.50	—	21.50
Fiberglass shower base					
Base, trim and valves (add rough-in)	P6@2.50	Ea	459.00	132.00	591.00
Add for larger base	—	Ea	21.50	—	21.50
Add for corner entry	—	Ea	21.50	—	21.50

22 Plumbing

	Craft@Hrs	Unit	Material	Labor	Total
Tub and shower doors					
Three panel sliding tub doors	P6@.500	Ea	413.00	26.50	439.50
Three panel sliding shower doors	P6@.500	Ea	362.00	26.50	388.50
Two panel sliding shower doors	P6@.500	Ea	305.00	26.50	331.50
One panel swinging shower door	P6@.500	Ea	147.00	26.50	173.50
Kitchen sinks					
Single compartment kitchen sink, 20" long, 21" wide, 8" deep, self rimming, countertop mounted, stainless steel with single handle faucet and deck spray					
Sink, trim and valves (add rough-in)	P6@2.00	Ea	383.00	106.00	489.00
Double compartment kitchen sink, 32" long, 21" wide, 8" deep, self rimming, countertop mounted, stainless steel with single handle faucet and deck spray					
Sink, trim and valves (add rough-in)	P6@2.15	Ea	286.00	114.00	400.00
Drinking fountains and water coolers					
Wall hung drinking fountains, 10" wide, 10" high, non-electric, white vitreous china					
Wall hung fountain, and trim (add rough-in)	P6@2.00	Ea	472.00	106.00	578.00
Recessed drinking fountains, 14" wide, 26" high, non-electric, white vitreous china					
Recessed fountain, and trim (add rough-in)	P6@2.50	Ea	837.00	132.00	969.00
Semi-recessed water cooler, vitreous china, refrigerated (no electrical work included)					
Semi-recessed cooler, and trim (add rough-in)	P6@2.50	Ea	147.00	132.00	279.00
Add for fully recessed	P6@.750	Ea	108.00	39.70	147.70
Free-standing water cooler, refrigerated (no electrical work included)					
Wall hung water cooler, and trim (add rough-in)	P6@2.50	Ea	959.00	132.00	1,091.00
Wash fountains					
54" circular wash fountain, precast stone (terrazzo), with foot operated water spray control					
Wash fountain, trim and valves (add rough-in)	P6@3.65	Ea	3,250.00	193.00	3,443.00
Add for stainless steel in lieu of precast stone	—	Ea	753.00	—	753.00
54" semi-circular wash fountain, precast stone (terrazzo), with foot operated water spray control					
Wash fountain, trim and valves (add rough-in)	P6@3.65	Ea	2,950.00	193.00	3,143.00
Add for stainless steel in lieu of precast stone	—	Ea	530.00	—	530.00
36" circular wash fountain, precast stone (terrazzo), with foot operated water spray control					
Wash fountain, trim and valves (add rough-in)	P6@3.50	Ea	2,620.00	185.00	2,805.00
Add for stainless steel in lieu of precast stone	—	Ea	452.00	—	452.00
36" semi-circular wash fountain, precast stone, (terrazzo), with foot operated water spray control					
Wash fountain, trim and valves (add rough-in)	P6@3.50	Ea	2,390.00	185.00	2,575.00
Add for stainless steel in lieu of precast stone	—	Ea	298.00	—	298.00
Service sinks					
Wall hung enameled cast iron slop sink, with wall-mounted faucet, hose and P-trap standard					
Slop sink, trim and valves (add rough-in)	P6@3.30	Ea	938.00	175.00	1,113.00
Floor mounted mop sink, precast molded stone (terrazzo), with wall mounted faucet and hose					
Mop sink, 24" x 24", 6" curbs (add rough-in)	P6@2.60	Ea	521.00	138.00	659.00
Mop sink, 32" x 32", 6" curbs (add rough-in)	P6@2.60	Ea	561.00	138.00	699.00
Mop sink, 36" x 36", 6" curbs (add rough-in)	P6@2.60	Ea	613.00	138.00	751.00
Add for 12" curbs, 6" drop front & stainless steel caps	—	Ea	297.00	—	297.00
Drench shower and emergency eye wash stations					
Drench shower, plastic pipe and head, wall mounted	P6@2.00	Ea	209.00	106.00	315.00
Drench shower galvanized pipe, free standing	P6@2.50	Ea	451.00	132.00	583.00
Drench shower, emergency eyewash combination	P6@2.75	Ea	1,220.00	146.00	1,366.00
Emergency eyewash station	P6@2.00	Ea	488.00	106.00	594.00
Walk-thru station, 18 heads	P6@12.5	Ea	3,140.00	661.00	3,801.00

22 Plumbing

	Craft@Hrs	Unit	Material	Labor	Total
Surgeons' scrub sink					
Wall-hung wash sink, white enameled cast iron, 48" long, 18" deep, trough-type with 2 twin-handled faucets and two soap dishes					
Wash sink, trim and valves (add rough-in)	P6@2.50	Ea	1,310.00	132.00	1,442.00
Add for foot or knee pedal operation	P6@.500	Ea	154.00	26.50	180.50
Add for electronic infrared hands free operation	P6@.500	Ea	189.00	26.50	215.50
Add for stainless steel in lieu of enameled cast iron	—	Ea	229.00	—	229.00
Floor sinks					
12" square sink, cast iron top and body (add rough-in)	P6@1.00	Ea	233.00	52.90	285.90
Add for an acid-resistant finish to the sink	—	Ea	39.00	—	39.00
Sauna Room Commercial dry type, with insulated prefabricated 6' wide by 12' long by 8' high enclosure, with premounted cedar inner walls and ceiling and three-tier benches, roof vent, electric stone floor-mounted heater module with thermostat regulator, grouted stone floor, sanitary floor drain with cleanout, adjoining three-stall fiberglass shower stall with fixtures and drain.					
Commercial sauna enclosure module	—	Ea	8,250.00	—	8,250.00
Prep & sealing of floor	B9@8.00	Ea	447.00	267.00	714.00
Pouring of floor	B9@8.00	Ea	—	267.00	267.00
Tiling of floor	B1@8.00	Ea	873.00	273.00	1,146.00
Ceiling fabrication	B1@8.00	Ea	—	273.00	273.00
Running of vents	SW@8.00	Ea	229.00	340.00	569.00
Running of drain	P6@4.00	Ea	161.00	212.00	373.00
Electrical for heat and lighting	CE@4.00	Ea	226.00	244.00	470.00
Mounting of benches	B1@4.00	Ea	—	136.00	136.00
Installation of sealed portal	B1@4.00	Ea	279.00	136.00	415.00
Running of CW/HW piping and valves	P6@8.00	Ea	523.00	423.00	946.00
3-stall shower module installation and piping	P6@16.0	Ea	1,200.00	847.00	2,047.00
Subtotal	—	Ea	3,938.00	3,418.00	7,356.00
Grand Total (with Sauna Module)	—	Ea	12,188.00	3,418.00	15,606.00

23 HVAC

Gas-fired heating equipment No gas pipe or electric runs included

Unit heaters, gas fired, ceiling suspended, with flue and gas valve, propeller fan with aluminized heat exchanger, Modine PAE series

50 MBtu input		M5@4.75	Ea	1,090.00	249.00	1,339.00
75 MBtu input		M5@4.75	Ea	1,190.00	249.00	1,439.00
125 MBtu input		M5@5.25	Ea	1,500.00	275.00	1,775.00
175 MBtu input		M5@5.50	Ea	1,670.00	288.00	1,958.00
225 MBtu input		Ml@6.75	Ea	1,910.00	378.00	2,288.00
300 MBtu input		Ml@7.50	Ea	2,350.00	420.00	2,770.00
400 MBtu input		Ml@8.75	Ea	3,120.00	489.00	3,609.00
Add for single stage intermittent ignition pilot		—	LS	247.00	—	247.00
Add for high efficiency units (PV series)		—	%	35.0	—	—
Add for stainless steel burner		—	%	20.0	—	—
Add for air blower style fan		—	%	10.0	—	—
Add for switch and thermostat		CE@1.00	Ea	65.30	61.00	126.30
Add for gas supply pipe connection		M5@1.75	Ea	122.00	91.60	213.60
Add for typical electric run, BX		E4@2.50	Ea	134.00	128.00	262.00

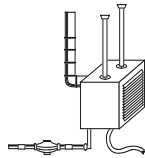

23 HVAC

	Craft@Hrs	Unit	Material	Labor	Total
Furnaces, wall type, upflow, gas fired with gas valve, flue vent and electronic ignition					
35 MBtu input	M5@4.25	Ea	1,150.00	223.00	1,373.00
50 MBtu input	M5@4.25	Ea	1,290.00	223.00	1,513.00
65 MBtu input	M5@4.25	Ea	1,300.00	223.00	1,523.00
Add for gas supply pipe connection	M5@1.75	Ea	121.00	91.60	212.60
Add for power vent kit (direct sidewall vent)	M5@2.50	Ea	148.00	131.00	279.00
Add for thermostat	CE@1.00	Ea	57.70	61.00	118.70
Furnaces, non-condensing gas fired, multi-positional, mid-efficiency with gas valve, flue vent and electronic ignition					
40 MBtu input, 80% AFUE	M5@4.25	Ea	1,300.00	223.00	1,523.00
60 MBtu input, 80% AFUE	M5@4.25	Ea	1,450.00	223.00	1,673.00
80 MBtu input, 80% AFUE	M5@4.25	Ea	1,550.00	223.00	1,773.00
100 MBtu input, 80% AFUE	M5@4.50	Ea	1,520.00	236.00	1,756.00
120 MBtu input, 80% AFUE	M5@4.50	Ea	1,630.00	236.00	1,866.00
140 MBtu input, 80% AFUE	M5@4.50	Ea	1,810.00	236.00	2,046.00
Add for gas supply pipe connection	M5@1.75	Ea	121.00	91.60	212.60
Add for power vent kit (direct sidewall vent)	M5@2.50	Ea	142.00	131.00	273.00
Add for thermostat	CE@1.00	Ea	57.70	61.00	118.70
Furnaces, condensing gas fired, upflow, high-efficiency with gas valve, flue vent and electronic ignition					
50 MBtu input, 90% AFUE	M5@4.25	Ea	2,320.00	223.00	2,543.00
70 MBtu input, 90% AFUE	M5@4.25	Ea	2,600.00	223.00	2,823.00
90 MBtu input, 90% AFUE	M5@4.25	Ea	2,610.00	223.00	2,833.00
110 MBtu input, 90% AFUE	M5@4.50	Ea	2,830.00	236.00	3,066.00
130 MBtu input, 90% AFUE	M5@4.50	Ea	2,840.00	236.00	3,076.00
Add for gas supply pipe connection	M5@1.75	Ea	121.00	91.60	212.60
Add for power vent kit (direct sidewall vent)	M5@2.50	Ea	148.00	131.00	279.00
Air curtain, gas fired, ceiling suspended, includes flue, vent, and electrical ignition					
256 MBtu, 2,840 CFM	Ml@7.50	Ea	2,590.00	420.00	3,010.00
290 MBtu, 4,740 CFM	Ml@8.25	Ea	2,830.00	462.00	3,292.00
400 MBtu, 5,660 CFM	Ml@9.75	Ea	3,120.00	545.00	3,665.00
525 MBtu, 7,580 CFM	Ml@11.0	Ea	3,270.00	615.00	3,885.00
630 MBtu, 9,480 CFM	Ml@12.5	Ea	3,660.00	699.00	4,359.00
850 MBtu, 11,400 CFM	Ml@16.0	Ea	5,210.00	895.00	6,105.00
Add for gas supply pipe connection	M5@1.75	Ea	121.00	91.60	212.60
Electric Heat					
Air curtain electric heaters, wall mounted, includes electrical connection only					
37" long, 9.5 kW	H9@6.33	Ea	1,040.00	387.00	1,427.00
49" long, 12.5 kW	H9@8.05	Ea	1,490.00	492.00	1,982.00
61" long, 16.0 kW	H9@11.2	Ea	1,760.00	685.00	2,445.00
Baseboard electric heaters, with remote thermostat					
185 watts per LF	CE@.175	LF	35.00	10.70	45.70

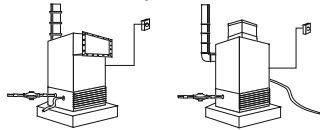

	Craft@Hrs	Unit	Material	Labor	Equipment	Total
--	-----------	------	----------	-------	-----------	-------

Hydronic hot water generators. U.S. Green Council and ASME "H" stamp certified to a rating of 95% AFUE (annual fuel usage efficiency) with EPA Tier II Nox emissions compliant burner, Kunkel safety valve, low-water cutoff, digital panel controls and automatic level controls, Parker Boiler 210-L series or equal. For commercial and light industrial applications. Equipment cost is for a 2-ton capacity forklift.						
4 BHP, 133 MBtu/Hr	M5@4.00	Ea	3,550.00	209.00	70.50	3,829.50
8 BHP, 263 MBtu/Hr	M5@4.00	Ea	4,730.00	209.00	70.50	5,009.50
12 BHP, 404 MBtu/Hr	M5@4.00	Ea	6,120.00	209.00	70.50	6,399.50
15 BHP, 514 MBtu/Hr	M5@5.00	Ea	9,260.00	262.00	88.10	9,610.10
19 BHP, 624 MBtu/Hr	M5@5.00	Ea	12,200.00	262.00	88.10	12,550.10
22 BHP, 724 MBtu/Hr	M5@6.00	Ea	12,700.00	314.00	106.00	13,120.00
29 BHP, 962 MBtu/Hr	M5@6.00	Ea	15,400.00	314.00	106.00	15,820.00
34 BHP, 1,125 MBtu/Hr	Ml@8.00	Ea	17,100.00	448.00	94.00	17,642.00

23 HVAC

	Craft@Hrs	Unit	Material	Labor	Equipment	Total
40 BHP, 1,336 MBtu/Hr	MI@8.00	Ea	19,700.00	448.00	94.00	20,242.00
47 BHP, 1,571 MBtu/Hr	MI@9.00	Ea	20,300.00	503.00	106.00	20,909.00
53 BHP, 1,758 MBtu/Hr	MI@10.0	Ea	22,000.00	559.00	118.00	22,677.00
63 BHP, 2,100 MBtu/Hr	MI@12.0	Ea	22,800.00	671.00	141.00	23,612.00
89 BHP, 3,001 MBtu/Hr	MI@18.0	Ea	29,200.00	1,010.00	211.00	30,421.00
118 BHP, 4,001 MBtu/Hr	MI@22.0	Ea	30,300.00	1,230.00	258.00	31,788.00

LEED certification (Leadership in Energy and Environmental Design) requires 88% boiler efficiency, recording controls, compliance with SCAQMD (S. Calif. Air Quality Management District) 1146.2 emission standards and zone thermostats.

Add for LEED registration and inspection	—	Ea	—	—	—	2,000.00
Add for LEED central performance monitor/recorder	—	Ea	2,770.00	—	—	2,770.00
Add for LEED-certified zone recording thermostats	—	Ea	414.00	—	—	414.00
Add for LEED-certified boiler with USGBC rating	—	Ea	%	10.0	—	—

Installation of packaged hydronic boilers. Add the cost of control wiring, supply lines (electric, feedwater and gas), drain line, circulating pump, expansion tank, vent stack, permits, final inspection and rental of an appliance doll, come-a-long and a 1/2-ton chain hoist if required.

Place 4' x 4' vibration pads	CF@.750	Ea	47.40	26.90	—	74.30
Connect gas and feedwater lines	P1@2.50	Ea	—	93.10	—	93.10
Mount interior boiler drain	P1@.500	Ea	9.48	18.60	—	28.08
Bore pipe hole through basement wall	P1@.250	Ea	—	9.31	—	9.31
Bore stack vent through exterior wall	P1@.250	Ea	—	9.31	—	9.31
Mount and edge-seal stack	P1@.500	Ea	48.70	18.60	—	67.30
Mount piping for circulating pump	P1@.450	Ea	—	16.70	—	16.70
Install expansion tank						
2.1 gallon	P1@.300	Ea	40.40	11.20	—	51.60
4.5 gallon	P1@.300	Ea	67.30	11.20	—	78.50

	Craft@Hrs	Unit	Material	Labor	Total
--	-----------	------	----------	-------	-------

Hydronic Heating

Hot water baseboard fin tube radiation, copper tube and aluminum fin element, commercial quality, 18 gauge enclosure. Add for control wiring.

9-7/8" enclosure and 1-1/4" element	P6@.280	LF	37.60	14.80	52.40
13-7/8" enclosure and 1-1/4" element, 2 rows	P6@.320	LF	65.00	16.90	81.90
9-7/8" enclosure only	P6@.130	LF	11.80	6.88	18.68
13-7/8" enclosure only	P6@.150	LF	18.10	7.94	26.04
1-1/4" element only	P6@.150	LF	26.70	7.94	34.64
1" element only	P6@.150	LF	13.30	7.94	21.24
3/4" element only	P6@.140	LF	10.70	7.41	18.11
Add for pipe connection and control valve	P6@2.25	Ea	248.00	119.00	367.00
Add for corners, fillers and caps, average per foot	—	%	10.0	—	—
End cap, 4"	P6@.090	Ea	8.12	4.76	12.88
End cap, 2"	P6@.090	Ea	4.10	4.76	8.86
Valve access door	P6@.250	Ea	20.30	13.20	33.50
Inside corner	P6@.120	Ea	8.08	6.35	14.43
Outside corner	P6@.120	Ea	11.50	6.35	17.85
Filler sleeve	P6@.090	Ea	5.14	4.76	9.90

Hot water baseboard fin tube radiation, steel element, commercial quality, 16 gauge, sloping top cover. Make additional allowances for control wiring.

9-7/8" enclosure and 1-1/4" steel element	P6@.330	LF	44.10	17.50	61.60
1-1/4" steel element only	P6@.160	LF	30.80	8.47	39.27
Add for pipe connection and control valve	P6@2.25	Ea	251.00	119.00	370.00

23 HVAC

	Craft@Hrs	Unit	Material	Labor	Total
Add for corners, fillers and caps, average per foot	—	%	10.0	—	—
End cap, 4"	P6@.090	Ea	15.70	4.76	20.46
End cap, 2"	P6@.090	Ea	7.57	4.76	12.33
Valve access door	P6@.250	Ea	20.80	13.20	34.00
Inside corner	P6@.120	Ea	14.10	6.35	20.45
Outside corner	P6@.120	Ea	18.70	6.35	25.05
Filler sleeve	P6@.090	Ea	10.10	4.76	14.86
Unit heaters, hot water, horizontal, fan driven					
12.5 MBtu, 200 CFM	M5@2.00	Ea	542.00	105.00	647.00
17 MBtu, 300 CFM	M5@2.00	Ea	599.00	105.00	704.00
25 MBtu, 500 CFM	M5@2.50	Ea	685.00	131.00	816.00
30 MBtu, 700 CFM	M5@3.00	Ea	722.00	157.00	879.00
50 MBtu, 1,000 CFM	M5@3.50	Ea	836.00	183.00	1,019.00
60 MBtu, 1,300 CFM	M5@4.00	Ea	996.00	209.00	1,205.00
Unit heaters, hot water, vertical, fan driven					
12.5 MBtu, 200 CFM	M5@2.00	Ea	611.00	105.00	716.00
17 MBtu, 300 CFM	M5@2.00	Ea	620.00	105.00	725.00
25 MBtu, 500 CFM	M5@2.50	Ea	804.00	131.00	935.00
30 MBtu, 700 CFM	M5@3.00	Ea	837.00	157.00	994.00
50 MBtu, 1,000 CFM	M5@3.50	Ea	1,010.00	183.00	1,193.00
60 MBtu, 1,300 CFM	M5@4.00	Ea	1,120.00	209.00	1,329.00
Steam Heating					
Steam baseboard radiation, per linear foot, wall mounted					
1/2" tube and cover	P6@.456	LF	14.00	24.10	38.10
3/4" tube and cover	P6@.493	LF	14.90	26.10	41.00
3/4" tube and cover, high capacity	P6@.493	LF	17.40	26.10	43.50
1/2" tube alone	P6@.350	LF	7.51	18.50	26.01
3/4" tube alone	P6@.377	LF	8.58	19.90	28.48
Unit heater, steam, horizontal, fan driven					
18 MBtu, 300 CFM	M5@2.00	Ea	506.00	105.00	611.00
45 MBtu, 500 CFM	M5@2.50	Ea	837.00	131.00	968.00
60 MBtu, 700 CFM	M5@3.00	Ea	946.00	157.00	1,103.00
85 MBtu, 1,000 CFM	M5@3.50	Ea	998.00	183.00	1,181.00
Unit heater, steam, vertical, fan driven					
12.5 MBtu, 200 CFM	M5@2.00	Ea	459.00	105.00	564.00
17 MBtu, 300 CFM	M5@2.00	Ea	469.00	105.00	574.00
40 MBtu, 500 CFM	M5@2.50	Ea	907.00	131.00	1,038.00
60 MBtu, 700 CFM	M5@3.00	Ea	1,050.00	157.00	1,207.00
70 MBtu, 1,000 CFM	M5@3.50	Ea	1,350.00	183.00	1,533.00
Hydronic Heating Specialties					
Air eliminator-purger, screwed connections					
3/4", cast iron, steam & water, 150 PSI	PF@.250	Ea	642.00	15.80	657.80
3/4", cast iron, 150 PSI water	PF@.250	Ea	206.00	15.80	221.80
1", cast iron, 150 PSI water	PF@.250	Ea	233.00	15.80	248.80
3/8", brass, 125 PSI steam	PF@.250	Ea	168.00	15.80	183.80
1/2", cast iron, 250 PSI steam	PF@.250	Ea	350.00	15.80	365.80
3/4", cast iron, 250 PSI steam	PF@.250	Ea	437.00	15.80	452.80
Airtrol fitting, 3/4"	PF@.300	Ea	74.30	18.90	93.20
Air eliminator vents, 1/4"	P1@.150	Ea	25.00	5.58	30.58
Atmospheric vacuum breakers, screwed					
1/2" vacuum breaker	PF@.210	Ea	36.10	13.20	49.30
3/4" vacuum breaker	PF@.250	Ea	38.30	15.80	54.10

23 HVAC

	Craft@Hrs	Unit	Material	Labor	Total
1" vacuum breaker	PF@.300	Ea	60.90	18.90	79.80
1-1/4" vacuum breaker	PF@.400	Ea	101.00	25.20	126.20
1-1/2" vacuum breaker	PF@.450	Ea	119.00	28.40	147.40
2" vacuum breaker	PF@.500	Ea	177.00	31.50	208.50
Circuit balancing valves, for hot water applications, certified low-lead compliance.					
1/2" circuit balancing valve	PF@.210	Ea	94.30	13.20	107.50
3/4" circuit balancing valve	PF@.250	Ea	94.30	15.80	110.10
1" circuit balancing valve	PF@.300	Ea	127.00	18.90	145.90
1-1/2" circuit balancing valve	PF@.450	Ea	178.00	28.40	206.40
Flow check valves, brass, threaded, horizontal type					
3/4" check valve	PF@.250	Ea	37.20	15.80	53.00
1" check valve	PF@.300	Ea	53.40	18.90	72.30
1-1/2" valve	PF@.350	Ea	117.00	22.10	139.10
2" valve	PF@.400	Ea	147.00	25.20	172.20
Pressure-reducing valves, bronze body, for water, gas and steam applications, lead free, threaded.					
1/2", 25-75 PSI	PF@.210	Ea	155.00	13.20	168.20
1/2", 10-35 PSI	PF@.210	Ea	176.00	13.20	189.20
3/4", 25-75 PSI	PF@.250	Ea	180.00	15.80	195.80
3/4", 10-35 PSI	PF@.250	Ea	206.00	15.80	221.80
1", 25-75 PSI	PF@.300	Ea	287.00	18.90	305.90
1", 10-35 PSI	PF@.300	Ea	314.00	18.90	332.90
1-1/4", 25-75 PSI	PF@.350	Ea	578.00	22.10	600.10
1-1/4", 10-35 PSI	PF@.350	Ea	629.00	22.10	651.10
1-1/2", 25-75 PSI	PF@.250	Ea	620.00	15.80	635.80
1-1/2", 10-35 PSI	PF@.250	Ea	708.00	15.80	723.80
2", 25-75 PSI	PF@.250	Ea	925.00	15.80	940.80
2", 10-35 PSI	PF@.250	Ea	978.00	15.80	993.80
Pressure regulators, feed water 25-75 PSI, cast iron, screwed connections					
3/4" regulator	PF@.250	Ea	111.00	15.80	126.80
1" regulator	PF@.300	Ea	168.00	18.90	186.90
1-1/4" regulator	PF@.400	Ea	229.00	25.20	254.20
1-1/2" regulator	PF@.450	Ea	331.00	28.40	359.40
2" regulator	PF@.600	Ea	532.00	37.80	569.80
2-1/2" regulator	PF@.700	Ea	798.00	44.20	842.20
Combination pressure relief and reducing valves					
1/2", brass body	PF@.210	Ea	139.00	13.20	152.20
3/4", cast iron body	PF@.250	Ea	213.00	15.80	228.80
Wye pattern bronze strainers, for water, gas and steam applications, complies with American Society of Mechanical Engineers Standard B16, Manufacturers Standardization Society, Instrumentation Society of America standards.					
Wye pattern strainers, screwed connections, 250 PSI, cast iron body					
3/4" strainer	PF@.260	Ea	15.10	16.40	31.50
1" strainer	PF@.330	Ea	19.10	20.80	39.90
1-1/4" strainer	PF@.440	Ea	27.60	27.80	55.40
1-1/2" strainer	PF@.495	Ea	31.90	31.20	63.10
2" strainer	PF@.550	Ea	50.30	34.70	85.00
Wye pattern strainers, screwed connections, 250 PSI, cast bronze body					
1/2" strainer	PF@.210	Ea	33.90	13.20	47.10
3/4" strainer	PF@.250	Ea	45.70	15.80	61.50
1" strainer	PF@.300	Ea	58.40	18.90	77.30
1-1/4" strainer	PF@.400	Ea	82.60	25.20	107.80
1-1/2" strainer	PF@.450	Ea	107.00	28.40	135.40
2" strainer	PF@.500	Ea	185.00	31.50	216.50

23 HVAC

	Craft@Hrs	Unit	Material	Labor	Total
Wye pattern strainers, screwed connections, 600 PSI, stainless steel body					
3/4" strainer	PF@.260	Ea	360.00	16.40	376.40
1" strainer	PF@.330	Ea	496.00	20.80	516.80
1-1/4" strainer	PF@.440	Ea	601.00	27.80	628.80
1-1/2" strainer	PF@.495	Ea	828.00	31.20	859.20
2" strainer	PF@.550	Ea	1,150.00	34.70	1,184.70
Wye pattern strainers, flanged connections, 125 PSI, cast iron body					
2" strainer	PF@.500	Ea	139.00	31.50	170.50
2-1/2" strainer	PF@.600	Ea	156.00	37.80	193.80
3" strainer	PF@.750	Ea	180.00	47.30	227.30
4" strainer	PF@1.35	Ea	307.00	85.20	392.20
6" strainer	PF@2.50	Ea	617.00	158.00	775.00
8" strainer	PF@3.00	Ea	1,040.00	189.00	1,229.00
Tempering valves, screwed connections, high temperature for hot water applications, complies with American Society of Mechanical Engineers Standard B16, Manufacturers Standardization Society, Instrumentation Society of America standards.					
3/4", screwed	PF@.250	Ea	616.00	15.80	631.80
1", screwed	PF@.300	Ea	882.00	18.90	900.90
1-1/4", screwed	PF@.400	Ea	1,260.00	25.20	1,285.20
1-1/2", screwed	PF@.450	Ea	1,540.00	28.40	1,568.40
2", screwed	PF@.500	Ea	1,930.00	31.50	1,961.50
Thermostatic mixing valves, 110 to 150 degrees F					
1/2", soldered	PF@.240	Ea	78.80	15.10	93.90
3/4", threaded	PF@.250	Ea	103.00	15.80	118.80
3/4", soldered	PF@.300	Ea	86.50	18.90	105.40
1", threaded	PF@.300	Ea	118.00	18.90	136.90
Float and thermostatic traps, cast iron body, parallel connection					
3/4" (15 to 75 PSI)	PF@.250	Ea	191.00	15.80	206.80
1" (15 to 30 PSI)	PF@.300	Ea	227.00	18.90	245.90
3/4"-1" (125 PSI)	PF@.250	Ea	294.00	15.80	309.80
3/4"-1" (175 PSI)	PF@.300	Ea	642.00	18.90	660.90
1-1/4" (15 to 30 PSI)	PF@.450	Ea	318.00	28.40	346.40
1-1/4"-1-1/2" (75 PSI)	PF@.450	Ea	541.00	28.40	569.40
1-1/4"-1-1/2" (125 PSI)	PF@.500	Ea	543.00	31.50	574.50
1-1/4"-1-1/2" (175 PSI)	PF@.500	Ea	779.00	31.50	810.50
1-1/2" (15 to 30 PSI)	PF@.450	Ea	479.00	28.40	507.40
2" (15 to 30 PSI)	PF@.450	Ea	1,630.00	28.40	1,658.40
2" (75 PSI)	PF@.550	Ea	1,640.00	34.70	1,674.70
2" (125 PSI)	PF@.600	Ea	1,650.00	37.80	1,687.80
2-1/2" (15 to 250 PSI)	PF@.800	Ea	4,200.00	50.50	4,250.50
Liquid level gauges					
3/4", aluminum	PF@.250	Ea	320.00	15.80	335.80
3/4", 125 PSI PVC	PF@.250	Ea	336.00	15.80	351.80
1/2", 175 PSI bronze	PF@.210	Ea	63.00	13.20	76.20
3/4", 150 PSI stainless steel	PF@.250	Ea	309.00	15.80	324.80
1", 150 PSI stainless steel	PF@.300	Ea	349.00	18.90	367.90
Tanks Double wall except as noted. Includes fittings and lift lugs. Add the cost of excavation, dewatering, shoring, supports, piping, backfill, paving and concrete.					
Underground steel oil storage tanks					
600 gallon	M1@4.86	Ea	9,130.00	272.00	9,402.00
2,500 gallon	M8@18.5	Ea	18,700.00	1,070.00	19,770.00
5,000 gallon	M8@24.0	Ea	23,500.00	1,390.00	24,890.00
10,000 gallon	M8@37.3	Ea	34,600.00	2,150.00	36,750.00
Add for standard hold down straps	—	%	5.0	—	—

23 HVAC

	Craft@Hrs	Unit	Material	Labor	Total
Above-ground horizontal steel oil storage tanks, with electric fuel pump, meter, shutoff nozzle and vents.					
300 gallon	Ml@2.98	Ea	4,590.00	167.00	4,757.00
500 gallon	Ml@3.80	Ea	5,860.00	213.00	6,073.00
1,000 gallon	M8@7.64	Ea	8,170.00	441.00	8,611.00
1,500 gallon	M8@8.29	Ea	12,300.00	479.00	12,779.00
2,000 gallon	M8@10.5	Ea	15,600.00	606.00	16,206.00
5,000 gallon	M8@29.6	Ea	23,300.00	1,710.00	25,010.00
Add for two-product tanks	—	%	35.0	—	—
Add for skid mount	—	%	10.0	—	—
Deduct for single-wall tanks	—	%	-50.0	—	—
Propane tanks with valves, underground					
1,000 gallon	M8@10.0	Ea	3,700.00	577.00	4,277.00
Underground double-wall fiberglass oil storage tanks. Add the cost of excavation, testing and permit.					
550 gallon	Ml@8.36	Ea	6,310.00	468.00	6,778.00
1,000 gallon	M8@16.8	Ea	11,400.00	970.00	12,370.00
2,000 gallon	M8@16.8	Ea	12,900.00	970.00	13,870.00
4,000 gallon	M8@25.9	Ea	17,000.00	1,500.00	18,500.00
6,000 gallon	M8@33.5	Ea	21,200.00	1,930.00	23,130.00
8,000 gallon	M8@33.5	Ea	24,700.00	1,930.00	26,630.00
10,000 gallon	M8@33.5	Ea	29,900.00	1,930.00	31,830.00
12,000 gallon	M8@84.4	Ea	34,900.00	4,870.00	39,770.00
15,000 gallon	M8@89.0	Ea	43,300.00	5,140.00	48,440.00
20,000 gallon	M8@89.0	Ea	51,900.00	5,140.00	57,040.00

26 Electrical

Typical In-Place Costs Preliminary estimates per square foot of floor area for all electrical work, including service entrance, distribution and lighting fixtures, by building type. These costs include the subcontractor's overhead and profit.

Commercial stores	—	SF	—	—	12.40
Market buildings	—	SF	—	—	12.70
Recreation facilities	—	SF	—	—	15.00
Schools	—	SF	—	—	17.30
Colleges	—	SF	—	—	24.70
Hospitals	—	SF	—	—	40.50
Office buildings	—	SF	—	—	15.30
Warehouses	—	SF	—	—	6.86
Parking lots	—	SF	—	—	2.60
Garages	—	SF	—	—	11.70

Underground Power and Communication Duct Type BE LTMC8 (encased burial) PVC duct in 20' lengths. Add for excavation, shoring, dewatering, spacers, concrete envelope around duct, backfill, compaction, wire, pavement removal and re-paving as required. Direct burial (DB) power and communication duct will cost about 25% more.

Single duct run

2" duct	E1@.053	LF	.62	2.79	3.41
3" duct	E1@.055	LF	1.20	2.89	4.09
4" duct	E1@.070	LF	2.17	3.68	5.85

Concrete Envelope for Duct No wire, duct, excavation, pavement removal or replacement included. Based on ready-mix concrete. Includes allowance for waste.

9" x 9" (.56 CF per linear foot)	E2@.020	LF	2.76	1.03	3.79
12" x 12" (1.00 CF per linear foot)	E2@.036	LF	4.92	1.85	6.77
12" x 24" (2.00 CF per linear foot)	E2@.072	LF	9.85	3.70	13.55
Per CY	E2@1.21	CY	133.00	62.10	195.10

26 Electrical

	Craft@Hrs	Unit	Material	Labor	Total
Precast Concrete Pull and Junction Box Reinforced concrete with appropriate inserts, cast iron frame, cover and pulling hooks. Overall dimensions as shown.					
Precast handholes, 4' deep					
2' wide, 3' long	E1@4.24	Ea	1,400.00	223.00	1,623.00
3' wide, 3' long	E1@5.17	Ea	2,090.00	272.00	2,362.00
4' wide, 4' long	E1@13.2	Ea	2,890.00	695.00	3,585.00
Precast power manholes, 7' deep					
4' wide, 6' long	E1@24.6	Ea	4,240.00	1,290.00	5,530.00
6' wide, 8' long	E1@26.6	Ea	4,720.00	1,400.00	6,120.00
8' wide, 10' long	E1@26.6	Ea	4,970.00	1,400.00	6,370.00
Light and Power Circuits Costs per circuit including stranded THHN copper wire (except where noted), conduit, handy box, cover, straps, fasteners and connectors, but without fixture, receptacle or switch, except as noted. Circuits for an exit light, fire alarm bell or suspended ceiling lighting system, 20 amp, with 4" junction box and 30' of 1/2" EMT conduit and copper THHN wire					
3 #12 solid wire	E4@2.68	Ea	39.90	138.00	177.90
4 #12 solid wire	E4@2.90	Ea	46.50	149.00	195.50
5 #12 solid wire	E4@3.14	Ea	53.10	161.00	214.10
Under-slab circuit, with 4" square junction box, 10' of 1/2" RSC and 20' of 1/2" PVC conduit					
3 #12 wire, 20 amp	E4@1.75	Ea	65.60	89.80	155.40
4 #12 wire, 20 amp	E4@1.97	Ea	72.20	101.00	173.20
5 #12 wire, 20 amp	E4@2.21	Ea	78.80	113.00	191.80
3 #10 wire, 30 amp	E4@2.00	Ea	67.80	103.00	170.80
4 #10 wire, 30 amp	E4@2.31	Ea	75.20	119.00	194.20
Under-slab circuit, with 4" square junction box, 10' of 1/2" RSC conduit, 20' of 1/2" PVC conduit and 6' of liquid-tight flexible conduit					
3 #12 wire, 20 amp	E4@2.41	Ea	79.90	124.00	203.90
4 #12 wire, 20 amp	E4@2.69	Ea	86.50	138.00	224.50
3 #10 wire, 30 amp	E4@2.75	Ea	82.10	141.00	223.10
4 #10 wire, 30 amp	E4@3.81	Ea	89.50	196.00	285.50
20 amp switch circuit, 277 volt, with 30' of 1/2" EMT conduit, switch, cover and 2 indenter connectors					
One gang box					
2 #12 wire, Single pole switch	E4@2.82	Ea	46.20	145.00	191.20
3 #12 wire, Three-way switch	E4@2.93	Ea	54.80	150.00	204.80
3 #12 wire, Four-way switch	E4@3.14	Ea	61.90	161.00	222.90
Two gang box					
2 #12 wire, Single pole switch	E4@2.95	Ea	51.50	151.00	202.50
3 #12 wire, Three-way switch	E4@3.08	Ea	62.10	158.00	220.10
3 #12 wire, Four-way switch	E4@3.24	Ea	76.20	166.00	242.20
15 amp switch circuit, 125 volt, with 30' of #14 two conductor Romex non-metallic cable (NM) with ground, switch, cover and switch connection					
One gang box					
Single pole switch	E4@1.05	Ea	32.90	53.90	86.80
Three-way switch	E4@1.18	Ea	34.90	60.60	95.50
Two gang box					
Single pole switch	E4@1.17	Ea	38.20	60.10	98.30
Single pole & receptacle	E4@1.43	Ea	39.50	73.40	112.90
Single pole & 3-way switch	E4@1.43	Ea	43.30	73.40	116.70
One two pole & 3-way switch	E4@1.66	Ea	43.30	85.20	128.50
20 amp 2 pole duplex receptacle outlet circuit, 125 volt, 30' of 1/2" EMT conduit, wire and specification grade receptacle, connectors and box					
3 #12 wire	E4@2.80	Ea	41.70	144.00	185.70
4 #12 wire	E4@3.06	Ea	48.30	157.00	205.30
5 #12 wire	E4@3.26	Ea	54.90	167.00	221.90

26 Electrical

	Craft@Hrs	Unit	Material	Labor	Total
Duplex receptacle outlet circuit with 30' of Romex non-metallic cable (NM) with ground, receptacle, cover and connection					
15 amp, 125 volt, #14/2 wire	E4@1.11	Ea	22.10	57.00	79.10
15 amp, 125 volt, #14/2 wire with ground fault circuit interrupter (GFCI)	E4@1.30	Ea	36.60	66.70	103.30
20 amp, 125 volt, #12/2 wire	E4@1.36	Ea	31.90	69.80	101.70
30 amp, 250 volt, #10/3 wire, dryer circuit	E4@1.77	Ea	68.70	90.90	159.60
50 amp, 250 volt, #8/3 wire, range circuit	E4@2.06	Ea	109.00	106.00	215.00
Rigid Galvanized Steel Conduit , standard wall. Installed exposed in a building either vertically or horizontally up to 10' above floor level. No wire, fittings or supports included. Each 10' length comes with one coupling. Add the cost of fittings, boxes, supports and wire.					
1/2" conduit	E4@.043	LF	3.18	2.21	5.39
3/4" conduit	E4@.054	LF	3.20	2.77	5.97
1" conduit	E4@.066	LF	5.15	3.39	8.54
1-1/4" conduit	E4@.077	LF	7.25	3.95	11.20
1-1/2" conduit	E4@.100	LF	8.57	5.13	13.70
2" conduit	E4@.116	LF	10.70	5.96	16.66
2-1/2" conduit	E4@.143	LF	20.50	7.34	27.84
3" conduit	E4@.164	LF	26.40	8.42	34.82
4" conduit	E4@.221	LF	33.90	11.30	45.20
Add for red plastic coating	—	%	80.0	—	—
Deduct for rigid steel conduit installed in a concrete slab or open trench	—	%	—	-40.0	—
90- or 45-degree ells, standard weight rigid galvanized steel, threaded both ends					
1/2" elbow	E4@.170	Ea	4.48	8.73	13.21
3/4" elbow	E4@.190	Ea	4.98	9.75	14.73
1" elbow	E4@.210	Ea	7.98	10.80	18.78
1-1/4" elbow	E4@.311	Ea	11.70	16.00	27.70
1-1/2" elbow	E4@.378	Ea	13.50	19.40	32.90
2" elbow	E4@.448	Ea	20.00	23.00	43.00
2-1/2" elbow	E4@.756	Ea	19.50	38.80	58.30
3" elbow	E4@1.10	Ea	47.50	56.50	104.00
4" elbow	E4@1.73	Ea	89.70	88.80	178.50
Add for 45 degree ells	—	%	7.0	—	—
Add for PVC coated ells	—	%	45.0	—	—
Rigid steel threaded couplings					
1/2"	E4@.062	Ea	1.48	3.18	4.66
3/4"	E4@.080	Ea	1.72	4.11	5.83
1"	E4@.092	Ea	3.46	4.72	8.18
1-1/4"	E4@.102	Ea	4.27	5.24	9.51
1-1/2"	E4@.140	Ea	5.66	7.19	12.85
2"	E4@.170	Ea	8.43	8.73	17.16
2-1/2"	E4@.202	Ea	11.00	10.40	21.40
3"	E4@.230	Ea	14.20	11.80	26.00
4"	E4@.425	Ea	21.30	21.80	43.10
Three-piece "Erickson" unions, by pipe size					
1"	E4@.394	Ea	7.96	20.20	28.16
Insulated grounding bushing					
1/2"	E4@.062	Ea	2.86	3.18	6.04
3/4"	E4@.080	Ea	3.74	4.11	7.85
1"	E4@.092	Ea	5.10	4.72	9.82
1-1/4"	E4@.102	Ea	7.41	5.24	12.65
1-1/2"	E4@.140	Ea	8.36	7.19	15.55
2"	E4@.170	Ea	8.85	8.73	17.58
3"	E4@.230	Ea	10.20	11.80	22.00
4"	E4@.425	Ea	13.60	21.80	35.40



26 Electrical

	Craft@Hrs	Unit	Material	Labor	Total
Insulated thermoplastic bushing					
1/2"	E4@.020	Ea	.21	1.03	1.24
3/4"	E4@.025	Ea	.29	1.28	1.57
1"	E4@.030	Ea	.68	1.54	2.22
1-1/4"	E4@.040	Ea	.86	2.05	2.91
1-1/2"	E4@.045	Ea	1.18	2.31	3.49
2"	E4@.050	Ea	1.75	2.57	4.32
2-1/2"	E4@.050	Ea	2.47	2.57	5.04
3"	E4@.070	Ea	2.90	3.59	6.49
Type A, C, LB, E, LL or LR threaded conduit body with cover and gasket					
1/2"	E4@.191	Ea	4.76	9.81	14.57
3/4"	E4@.238	Ea	6.54	12.20	18.74
1"	E4@.285	Ea	9.68	14.60	24.28
1-1/4"	E4@.358	Ea	11.80	18.40	30.20
1-1/2"	E4@.456	Ea	15.70	23.40	39.10
2"	E4@.598	Ea	24.20	30.70	54.90
2-1/2"	E4@1.43	Ea	41.70	73.40	115.10
3"	E4@1.77	Ea	48.40	90.90	139.30
4"	E4@2.80	Ea	93.30	144.00	237.30
Type T threaded conduit body, with cover and gasket					
1/2"	E4@.285	Ea	5.72	14.60	20.32
3/4"	E4@.358	Ea	7.92	18.40	26.32
1"	E4@.433	Ea	11.30	22.20	33.50
1-1/4"	E4@.534	Ea	22.20	27.40	49.60
1-1/2"	E4@.679	Ea	20.90	34.90	55.80
2"	E4@.889	Ea	24.50	45.60	70.10
2-1/2"	E4@2.15	Ea	57.00	110.00	167.00
3"	E4@2.72	Ea	81.60	140.00	221.60
4"	E4@4.22	Ea	172.00	217.00	389.00
Service entrance cap, threaded					
1/2"	E4@.319	Ea	4.31	16.40	20.71
3/4"	E4@.373	Ea	4.84	19.10	23.94
1"	E4@.376	Ea	7.92	19.30	27.22
1-1/4"	E4@.482	Ea	8.52	24.70	33.22
1-1/2"	E4@.536	Ea	10.90	27.50	38.40
2"	E4@.591	Ea	15.30	30.30	45.60
2-1/2"	E4@.671	Ea	43.90	34.40	78.30
3"	E4@.749	Ea	80.00	38.50	118.50
4"	E4@.912	Ea	104.00	46.80	150.80
Add for heights over 10' to 20'	—	%	—	20.0	—

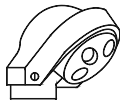
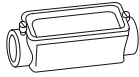
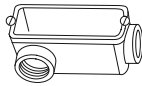

Electric Metallic Tubing (EMT) Installed exposed in a building either vertically or horizontally up to 10' above floor level. No wire, fittings or supports included except as noted.

1/2" conduit	E4@.036	LF	.56	1.85	2.41
3/4" conduit	E4@.043	LF	.95	2.21	3.16
1" conduit	E4@.055	LF	1.60	2.82	4.42
1-1/4" conduit	E4@.067	LF	2.86	3.44	6.30
1-1/2" conduit	E4@.070	LF	3.15	3.59	6.74
2" conduit	E4@.086	LF	3.70	4.42	8.12
2-1/2" conduit	E4@.106	LF	7.19	5.44	12.63
3" conduit	E4@.127	LF	9.08	6.52	15.60
4" conduit	E4@.170	LF	12.30	8.73	21.03

26 Electrical

	Craft@Hrs	Unit	Material	Labor	Total
EMT 90-degree elbow					
1/2"	E4@.143	Ea	3.56	7.34	10.90
3/4"	E4@.170	Ea	4.99	8.73	13.72
1"	E4@.190	Ea	7.53	9.75	17.28
1-1/4"	E4@.216	Ea	8.68	11.10	19.78
1-1/2"	E4@.288	Ea	10.80	14.80	25.60
2"	E4@.358	Ea	24.20	18.40	42.60
2-1/2"	E4@.648	Ea	22.60	33.30	55.90
3"	E4@.858	Ea	29.30	44.00	73.30
4"	E4@1.33	Ea	55.70	68.30	124.00
EMT 90-degree pull elbow					
1/2" pull elbow	E4@.143	Ea	4.14	7.34	11.48
3/4" pull elbow	E4@.170	Ea	5.99	8.73	14.72
1" pull elbow	E4@.190	Ea	15.80	9.75	25.55
1-1/4" pull elbow	E4@.216	Ea	19.80	11.10	30.90
1-1/2" pull elbow	E4@.288	Ea	18.40	14.80	33.20
2" pull elbow	E4@.358	Ea	26.80	18.40	45.20
2-1/2" pull elbow	E4@.648	Ea	44.40	33.30	77.70
3" pull elbow	E4@.858	Ea	51.60	44.00	95.60
4" pull elbow	E4@1.33	Ea	94.50	68.30	162.80
EMT set screw connector, die cast					
1/2" EMT connector	E4@.085	Ea	.60	4.36	4.96
3/4" EMT connector	E4@.096	Ea	.73	4.93	5.66
1" EMT connector	E4@.124	Ea	.71	6.37	7.08
1-1/4" EMT connector	E4@.143	Ea	.72	7.34	8.06
1-1/2" EMT connector	E4@.162	Ea	2.15	8.32	10.47
2" EMT connector	E4@.237	Ea	2.75	12.20	14.95
2-1/2" EMT connector	E4@.363	Ea	9.36	18.60	27.96
3" EMT connector	E4@.479	Ea	9.41	24.60	34.01
4" EMT connector	E4@.655	Ea	11.70	33.60	45.30
Add for insulated set-screw connector	—	%	41.0	—	—
EMT compression connector, die cast					
1/2" EMT connector	E4@.085	Ea	.71	4.36	5.07
3/4" EMT connector	E4@.096	Ea	.99	4.93	5.92
1" EMT connector	E4@.124	Ea	.45	6.37	6.82
1-1/4" EMT connector	E4@.143	Ea	.29	7.34	7.63
1-1/2" EMT connector	E4@.162	Ea	1.49	8.32	9.81
2" EMT connector	E4@.237	Ea	4.70	12.20	16.90
2-1/2" EMT connector	E4@.363	Ea	12.50	18.60	31.10
3" EMT connector	E4@.479	Ea	12.70	24.60	37.30
4" EMT connector	E4@.655	Ea	16.70	33.60	50.30
Add for insulated compression connector	—	%	130.0	—	—
Add for raintight compression connector	—	%	121.0	—	—
EMT set screw coupling, steel					
1/2" EMT coupling	E4@.085	Ea	.31	4.36	4.67
3/4" EMT coupling	E4@.096	Ea	.49	4.93	5.42
1" EMT coupling	E4@.124	Ea	1.15	6.37	7.52
1-1/4" EMT coupling	E4@.143	Ea	1.87	7.34	9.21
1-1/2" EMT coupling	E4@.162	Ea	3.15	8.32	11.47
2" EMT coupling	E4@.237	Ea	2.75	12.20	14.95
2-1/2" EMT coupling	E4@.363	Ea	3.86	18.60	22.46
3" EMT coupling	E4@.479	Ea	4.88	24.60	29.48
4" EMT coupling	E4@.655	Ea	6.91	33.60	40.51
Add for insulated set-screw connector	—	%	130.0	—	—

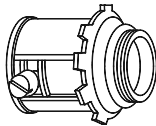

26 Electrical

	Craft@Hrs	Unit	Material	Labor	Total
EMT compression coupling, die cast, rain tight					
1/2" EMT coupling	E4@.085	Ea	1.58	4.36	5.94
3/4" EMT coupling	E4@.096	Ea	2.27	4.93	7.20
1" EMT coupling	E4@.124	Ea	3.62	6.37	9.99
1-1/4" EMT coupling	E4@.143	Ea	6.47	7.34	13.81
1-1/2" EMT coupling	E4@.162	Ea	9.36	8.32	17.68
2" EMT coupling	E4@.237	Ea	13.20	12.20	25.40
2-1/2" EMT coupling	E4@.363	Ea	42.60	18.60	61.20
3" EMT coupling	E4@.479	Ea	54.30	24.60	78.90
4" EMT coupling	E4@.655	Ea	115.00	33.60	148.60
Add for heights over 10' to 20'	—	%	—	20.0	—

EMT Conduit with Wire THHN wire pulled in EMT conduit bent each 10', with one tap-on coupling each 10', one set screw connector each 50' and a strap and lag screw each 6'. Installed exposed on walls or ceilings. Add 15% to the labor cost for heights over 10' to 20'. Use these figures for preliminary estimates.

1-1/2" EMT conduit and wire as shown below					
2 #1 aluminum, 1 #8 copper	E4@.140	LF	5.86	7.19	13.05
3 #1 aluminum, 1 #8 copper	E4@.156	LF	6.87	8.01	14.88
4 #1 aluminum, 1 #8 copper	E4@.173	LF	7.88	8.88	16.76
4 #4 copper, 1 #8 copper	E4@.162	LF	7.42	8.32	15.74
2 #3 copper, 1 #8 copper	E4@.140	LF	6.30	7.19	13.49
3 #3 copper, 1 #8 copper	E4@.155	LF	7.53	7.96	15.49
4 #3 copper, 1 #8 copper	E4@.170	LF	8.76	8.73	17.49
2 #1 copper, 1 #8 copper	E4@.146	LF	8.75	7.50	16.25
3 #1 copper, 1 #8 copper	E4@.164	LF	11.20	8.42	19.62
4 #1 copper, 1 #8 copper	E4@.183	LF	13.70	9.40	23.10
2" EMT conduit and wire as shown below					
2 #2/0 aluminum, 1 #6 copper	E4@.170	LF	7.58	8.73	16.31
3 #2/0 aluminum, 1 #6 copper	E4@.190	LF	9.04	9.75	18.79
4 #2/0 aluminum, 1 #6 copper	E4@.210	LF	10.50	10.80	21.30
2 #3/0 aluminum, 1 #6 copper	E4@.174	LF	8.30	8.93	17.23
3 #3/0 aluminum, 1 #6 copper	E4@.195	LF	10.10	10.00	20.10
4 #3/0 aluminum, 1 #6 copper	E4@.218	LF	11.90	11.20	23.10
2 #1/0 copper, 1 #6 copper	E4@.171	LF	9.55	8.78	18.33
3 #1/0 copper, 1 #6 copper	E4@.193	LF	12.00	9.91	21.91
4 #1/0 copper, 1 #6 copper	E4@.213	LF	14.40	10.90	25.30
2 #3/0 copper, 1 #4 copper	E4@.175	LF	11.80	8.98	20.78
3 #3/0 copper, 1 #4 copper	E4@.197	LF	15.30	10.10	25.40
2-1/2" EMT conduit and wire as shown below					
2 250 MCM alum, 1 #4 copper	E4@.210	LF	13.90	10.80	24.70
3 250 MCM alum, 1 #4 copper	E4@.237	LF	16.40	12.20	28.60
4 #3 copper, 1 #4 copper	E4@.216	LF	13.90	11.10	25.00
2 #4 copper, 1 #2 copper	E4@.186	LF	11.30	9.55	20.85
3 #4 copper, 1 #2 copper	E4@.198	LF	12.20	10.20	22.40
4 #4 copper, 1 #2 copper	E4@.210	LF	13.10	10.80	23.90
3 250 MCM copper, 1 #2 copper	E4@.253	LF	25.90	13.00	38.90
3" EMT conduit and wire as shown below					
4 250 MCM alum, 1 #4 copper	E4@.288	LF	20.80	14.80	35.60
4 250 MCM copper, 1 #2 copper	E4@.290	LF	33.30	14.90	48.20
5 250 MCM copper, 1 #2 copper	E4@.319	LF	38.80	16.40	55.20

26 Electrical

	Craft@Hrs	Unit	Material	Labor	Total
EMT Conduit Circuits Cost per circuit based on 30' run from the panel. Includes THHN copper wire pulled in conduit, 2 compression connectors, 2 couplings, conduit bending, straps, bolts and washers. Three-wire circuits are 120, 240 or 277 volt 1 phase, with 2 conductors and ground. Four-wire circuits are 120/208 or 480 volt 3 phase, with 3 conductors and ground. Five-wire circuits are 120/208 or 480 volt 3 phase, with 3 conductors, neutral and ground. Installed exposed in vertical or horizontal runs to 10' above floor level in a building. Add 15% to the manhours and labor costs for heights over 10' to 20'. Use these figures for preliminary estimates. Based on commercial quantity discounts.					
15 amp circuits					
3 #14 wire, 1/2" conduit	E4@2.39	Ea	32.10	123.00	155.10
4 #14 wire, 1/2" conduit	E4@2.58	Ea	36.50	132.00	168.50
20 amp circuits					
3 #12 wire, 1/2" conduit	E4@2.49	Ea	40.00	128.00	168.00
4 #12 wire, 1/2" conduit	E4@2.72	Ea	47.10	140.00	187.10
5 #12 wire, 1/2" conduit	E4@2.95	Ea	54.10	151.00	205.10
30 amp circuits					
3 #10 wire, 1/2" conduit	E4@2.75	Ea	43.20	141.00	184.20
4 #10 wire, 1/2" conduit	E4@3.08	Ea	51.30	158.00	209.30
5 #10 wire, 3/4" conduit	E4@3.58	Ea	71.40	184.00	255.40
50 amp circuits					
3 #8 wire, 3/4" conduit	E4@2.98	Ea	73.50	153.00	226.50
4 #8 wire, 3/4" conduit	E4@3.32	Ea	87.80	170.00	257.80
5 #8 wire, 1" conduit	E4@4.02	Ea	122.00	206.00	328.00
65 amp circuits					
2 #6, 1 #8 wire, 1" conduit	E4@3.42	Ea	106.00	176.00	282.00
3 #6, 1 #8 wire, 1" conduit	E4@3.76	Ea	126.00	193.00	319.00
4 #6, 1 #8 wire, 1-1/4" conduit	E4@4.48	Ea	185.00	230.00	415.00
85 amp circuits in 1-1/4" conduit					
2 #4, 1 #8 wire	E4@3.89	Ea	156.00	200.00	356.00
3 #4, 1 #8 wire	E4@4.25	Ea	183.00	218.00	401.00
4 #4, 1 #8 wire	E4@4.48	Ea	210.00	230.00	440.00
100 amp circuits in 1-1/2" conduit					
2 #3, 1 #8 wire	E4@4.20	Ea	189.00	216.00	405.00
3 #3, 1 #8 wire	E4@4.66	Ea	226.00	239.00	465.00
4 #3, 1 #8 wire	E4@5.10	Ea	263.00	262.00	525.00
125 amp circuits in 1-1/2" conduit					
2 #1, 1 #8 wire	E4@4.40	Ea	263.00	226.00	489.00
3 #1, 1 #8 wire	E4@4.92	Ea	336.00	253.00	589.00
4 #1, 1 #8 wire	E4@5.47	Ea	410.00	281.00	691.00
150 amp circuits in 2" conduit					
2 #1/0, 1 #6 wire	E4@5.16	Ea	286.00	265.00	551.00
3 #1/0, 1 #6 wire	E4@5.78	Ea	360.00	297.00	657.00
4 #1/0, 1 #6 wire	E4@6.43	Ea	433.00	330.00	763.00
200 amp circuits in 2" conduit					
2 #3/0, 1 #4 wire	E4@5.49	Ea	355.00	282.00	637.00
3 #3/0, 1 #4 wire	E4@6.27	Ea	460.00	322.00	782.00
4 #3/0, 1 #4 wire	E4@7.80	Ea	810.00	400.00	1,210.00
225 amp circuits in 2-1/2" conduit					
2 #4/0, 1 #2 wire	E4@6.48	Ea	547.00	333.00	880.00
3 #4/0, 1 #2 wire	E4@7.33	Ea	679.00	376.00	1,055.00
4 #4/0, 1 #2 wire	E4@8.19	Ea	810.00	420.00	1,230.00
250 amp circuits in 2-1/2" conduit					
2 250 MCM, 1 #2 wire	E4@6.63	Ea	614.00	340.00	954.00
3 250 MCM, 1 #2 wire	E4@8.24	Ea	778.00	423.00	1,201.00
4 250 MCM, 1 #2 wire	E4@9.56	Ea	943.00	491.00	1,434.00

26 Electrical

	Craft@Hrs	Unit	Material	Labor	Total
Intermediate Metal Conduit (IMC) Installed exposed in a building either vertically or horizontally up to 10' above floor level. No wire, fittings or supports included.					
1/2" conduit	E4@.038	LF	2.86	1.95	4.81
3/4" conduit	E4@.048	LF	3.21	2.46	5.67
1" conduit	E4@.056	LF	4.98	2.88	7.86
1-1/4" conduit	E4@.073	LF	6.01	3.75	9.76
1-1/2" conduit	E4@.086	LF	8.15	4.42	12.57
2" conduit	E4@.101	LF	9.93	5.19	15.12
2-1/2" conduit	E4@.127	LF	21.00	6.52	27.52
3" conduit	E4@.146	LF	24.40	7.50	31.90
PVC Schedule 40 Conduit Installed in or under a building slab. No wire, fittings or supports included.					
1/2"	E4@.030	LF	.59	1.54	2.13
3/4"	E4@.036	LF	.78	1.85	2.63
1"	E4@.046	LF	1.02	2.36	3.38
1-1/4"	E4@.056	LF	1.53	2.88	4.41
1-1/2"	E4@.061	LF	1.70	3.13	4.83
2"	E4@.072	LF	2.15	3.70	5.85
2-1/2"	E4@.089	LF	3.76	4.57	8.33
3"	E4@.105	LF	5.03	5.39	10.42
3-12"	E4@.130	LF	5.78	6.67	12.45
4"	E4@.151	LF	5.05	7.75	12.80
5"	E4@.176	LF	9.36	9.04	18.40
PVC Schedule 80 Conduit Installed in or under a building slab. No wire, fittings or supports included.					
1/2"	E4@.030	LF	.88	1.54	2.42
3/4"	E4@.036	LF	1.28	1.85	3.13
1"	E4@.046	LF	1.68	2.36	4.04
1-1/4"	E4@.056	LF	2.04	2.88	4.92
1-1/2"	E4@.061	LF	2.66	3.13	5.79
2"	E4@.072	LF	3.27	3.70	6.97
2-1/2"	E4@.089	LF	4.75	4.57	9.32
3"	E4@.105	LF	6.09	5.39	11.48
Schedule 40 PVC conduit coupling					
1/2" coupling	E4@.020	Ea	.40	1.03	1.43
3/4" coupling	E4@.051	Ea	.45	2.62	3.07
1" coupling	E4@.062	Ea	.65	3.18	3.83
1-1/4" coupling	E4@.078	Ea	.98	4.00	4.98
1-1/2" coupling	E4@.084	Ea	1.20	4.31	5.51
2" coupling	E4@.102	Ea	1.37	5.24	6.61
2-1/2" coupling	E4@.113	Ea	3.33	5.80	9.13
3" coupling	E4@.129	Ea	3.20	6.62	9.82
4" coupling	E4@.156	Ea	6.84	8.01	14.85
90-degree Schedule 40 non-metallic elbow					
1/2" ell	E4@.082	Ea	.90	4.21	5.11
3/4" ell	E4@.102	Ea	1.26	5.24	6.50
1" ell	E4@.124	Ea	1.73	6.37	8.10
1-1/4" ell	E4@.154	Ea	2.83	7.91	10.74
1-1/2" ell	E4@.195	Ea	4.20	10.00	14.20
2" ell	E4@.205	Ea	4.80	10.50	15.30
2-1/2" ell	E4@.226	Ea	8.58	11.60	20.18
3" ell	E4@.259	Ea	13.50	13.30	26.80
4" ell	E4@.313	Ea	20.80	16.10	36.90
1/2" access pull ell	E4@.082	Ea	4.49	4.21	8.70
3/4" access pull ell	E4@.102	Ea	5.15	5.24	10.39
1-1/4" ell, 24" radius	E4@.154	Ea	35.20	7.91	43.11

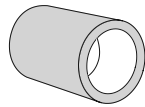

26 Electrical

	Craft@Hrs	Unit	Material	Labor	Total
1-1/2" ell, 24" radius	E4@.195	Ea	11.50	10.00	21.50
2" ell, 24" radius	E4@.205	Ea	19.60	10.50	30.10
2" ell, 36" radius	E4@.205	Ea	25.30	10.50	35.80
2-1/2" ell, 24" radius	E4@.226	Ea	32.60	11.60	44.20
2-1/2" ell, 36" radius	E4@.226	Ea	31.70	11.60	43.30
3" ell, 24" radius	E4@.259	Ea	36.20	13.30	49.50
Increase for 45 or 30 degree ells	—	%	40.0	—	—
90-degree Schedule 80 non-metallic elbow					
1" ell	E4@.124	Ea	3.27	6.37	9.64
1-1/4" ell	E4@.154	Ea	6.35	7.91	14.26
1-1/2" ell	E4@.195	Ea	6.65	10.00	16.65
2" ell	E4@.205	Ea	8.48	10.50	18.98
2-1/2" ell	E4@.226	Ea	16.80	11.60	28.40
1-1/4" ell, 24" radius	E4@.124	Ea	30.40	6.37	36.77
1-1/2" ell, 24" radius	E4@.168	Ea	12.30	8.63	20.93
2" ell, 24" radius	E4@.205	Ea	18.70	10.50	29.20
2" ell, 36" radius	E4@.205	Ea	37.20	10.50	47.70
2-1/2" ell, 24" radius	E4@.226	Ea	27.12	11.60	38.72
2" ell, 36" radius	E4@.226	Ea	37.20	11.60	48.80
3" ell, 36" radius	E4@.226	Ea	69.90	11.60	81.50
PVC conduit end bell					
1" bell end	E4@.105	Ea	2.81	5.39	8.20
1-1/4" bell end	E4@.115	Ea	3.90	5.90	9.80
1-1/2" bell end	E4@.124	Ea	3.79	6.37	10.16
2" bell end	E4@.143	Ea	5.60	7.34	12.94
2-1/2" bell end	E4@.221	Ea	5.87	11.30	17.17
3" bell end	E4@.285	Ea	8.37	14.60	22.97
PVC bell end reducer					
3" to 2-1/2"	E4@.200	Ea	21.50	10.30	31.80
4" to 3"	E4@.250	Ea	27.20	12.80	40.00
Thermoplastic insulating bushing					
1/2" bushing	E4@.025	Ea	.21	1.28	1.49
3/4" bushing	E4@.025	Ea	.16	1.28	1.44
1" bushing	E4@.030	Ea	.62	1.54	2.16
1-1/4" bushing	E4@.040	Ea	.79	2.05	2.84
1-1/2" bushing	E4@.040	Ea	1.15	2.05	3.20
2" bushing	E4@.050	Ea	1.53	2.57	4.10
2-1/2" bushing	E4@.050	Ea	2.25	2.57	4.82
3" bushing	E4@.070	Ea	2.89	3.59	6.48
PVC reducer bushing, Schedule 40, socket ends					
3/4" x 1/2" bushing	E4@.030	Ea	1.26	1.54	2.80
1" x 1/2" bushing	E4@.030	Ea	2.11	1.54	3.65
1" x 3/4" bushing	E4@.040	Ea	2.76	2.05	4.81
1-1/4" x 1" bushing	E4@.050	Ea	3.20	2.57	5.77
1-1/2" x 1" bushing	E4@.050	Ea	2.96	2.57	5.53
1-1/2" x 1-1/4" bushing	E4@.050	Ea	3.57	2.57	6.14
2" x 1-1/4" bushing	E4@.050	Ea	4.15	2.57	6.72
2" x 1-1/2" bushing	E4@.070	Ea	4.23	3.59	7.82
3" x 2" bushing	E4@.100	Ea	11.00	5.13	16.13
PVC conduit box adapter					
1/2" adapter	E4@.050	Ea	.70	2.57	3.27
3/4" adapter	E4@.060	Ea	.80	3.08	3.88
1" adapter	E4@.080	Ea	.83	4.11	4.94
1-1/4" adapter	E4@.100	Ea	1.23	5.13	6.36
1-1/2" adapter	E4@.100	Ea	1.38	5.13	6.51
2" adapter	E4@.150	Ea	1.56	7.70	9.26

26 Electrical

	Craft@Hrs	Unit	Material	Labor	Total
PVC female conduit adapter, for joining conduit to threaded fittings					
1/2" adapter	E4@.050	Ea	.45	2.57	3.02
3/4" adapter	E4@.060	Ea	.55	3.08	3.63
1" adapter	E4@.080	Ea	.71	4.11	4.82
1-1/4" adapter	E4@.100	Ea	1.11	5.13	6.24
1-1/2" adapter	E4@.100	Ea	.98	5.13	6.11
2" adapter	E4@.150	Ea	.52	7.70	8.22
2-1/2" adapter	E4@.178	Ea	3.24	9.14	12.38
4" adapter	E4@.244	Ea	6.64	12.50	19.14
PVC male conduit adapter, for joining conduit to threaded fittings					
1/2" adapter	E4@.050	Ea	.50	2.57	3.07
3/4" adapter	E4@.060	Ea	.50	3.08	3.58
1" adapter	E4@.080	Ea	.75	4.11	4.86
1-1/4" adapter	E4@.100	Ea	1.20	5.13	6.33
1-1/2" adapter	E4@.100	Ea	1.26	5.13	6.39
2" adapter	E4@.150	Ea	1.59	7.70	9.29
2-1/2" adapter	E4@.178	Ea	1.98	9.14	11.12
3" adapter	E4@.244	Ea	3.57	12.50	16.07
Type T PVC conduit body (access fitting)					
1/2" conduit body	E4@.150	Ea	3.57	7.70	11.27
3/4" conduit body	E4@.184	Ea	4.56	9.45	14.01
1" conduit body	E4@.225	Ea	4.79	11.60	16.39
1-1/4" conduit body	E4@.300	Ea	6.69	15.40	22.09
1-1/2" conduit body	E4@.350	Ea	9.27	18.00	27.27
2" conduit body	E4@.400	Ea	14.70	20.50	35.20
Type C PVC conduit body (access fitting)					
1/2" conduit body	E4@.100	Ea	4.23	5.13	9.36
3/4" conduit body	E4@.132	Ea	5.85	6.78	12.63
1" conduit body	E4@.164	Ea	6.48	8.42	14.90
1-1/4" conduit body	E4@.197	Ea	9.98	10.10	20.08
1-1/2" conduit body	E4@.234	Ea	9.34	12.00	21.34
2" conduit body	E4@.263	Ea	19.40	13.50	32.90
Type LB PVC conduit body (access fitting)					
1/2" conduit body	E4@.100	Ea	3.57	5.13	8.70
3/4" conduit body	E4@.132	Ea	4.56	6.78	11.34
1" conduit body	E4@.164	Ea	4.80	8.42	13.22
1-1/4" conduit body	E4@.197	Ea	6.40	10.10	16.50
1-1/2" conduit body	E4@.234	Ea	7.90	12.00	19.90
2" conduit body	E4@.263	Ea	12.50	13.50	26.00
3" conduit body	E4@.300	Ea	44.50	15.40	59.90
4" conduit body	E4@.350	Ea	48.60	18.00	66.60
Type LL PVC conduit body (access fitting)					
1/2" conduit body	E4@.100	Ea	3.57	5.13	8.70
3/4" conduit body	E4@.132	Ea	4.56	6.78	11.34
1" conduit body	E4@.164	Ea	4.80	8.42	13.22
1-1/4" conduit body	E4@.197	Ea	7.10	10.10	17.20
1-1/2" conduit body	E4@.234	Ea	8.00	12.00	20.00
2" conduit body	E4@.263	Ea	14.70	13.50	28.20
Type LR PVC conduit body (access fitting)					
1/2" conduit body	E4@.100	Ea	3.57	5.13	8.70
3/4" conduit body	E4@.132	Ea	4.56	6.78	11.34
1" conduit body	E4@.164	Ea	4.80	8.42	13.22
1-1/4" conduit body	E4@.197	Ea	8.49	10.10	18.59
1-1/2" conduit body	E4@.234	Ea	8.78	12.00	20.78
2" conduit body	E4@.263	Ea	15.40	13.50	28.90

26 Electrical

	Craft@Hrs	Unit	Material	Labor	Total
Two-hole PVC clamp					
1/2" clamp	E4@.100	Ea	.27	5.13	5.40
3/4" clamp	E4@.100	Ea	.39	5.13	5.52
1" clamp	E4@.125	Ea	.47	6.42	6.89
1-1/4" clamp	E4@.150	Ea	.60	7.70	8.30
1-1/2" clamp	E4@.150	Ea	.67	7.70	8.37
2" clamp	E4@.175	Ea	.71	8.98	9.69
3" clamp	E4@.175	Ea	2.36	8.98	11.34
PVC Conduit with Wire Includes THHN wire pulled in Type 40 rigid PVC heavy wall conduit placed in a slab. Use these figures for preliminary estimates. Includes one rigid coupling every 10'. Add for fittings as required. Based on commercial quantity discounts.					
1/2" PVC conduit with wire					
3 #12 solid copper	E4@.054	LF	1.29	2.77	4.06
4 #12 solid copper	E4@.061	LF	1.51	3.13	4.64
5 #12 solid copper	E4@.069	LF	1.73	3.54	5.27
3 #10 solid copper	E4@.062	LF	1.36	3.18	4.54
4 #10 solid copper	E4@.073	LF	1.61	3.75	5.36
3/4" PVC conduit with wire					
5 #10 solid copper	E4@.089	LF	2.04	4.57	6.61
3 #8 copper	E4@.069	LF	2.25	3.54	5.79
4 #8 copper	E4@.080	LF	2.73	4.11	6.84
1" PVC conduit with wire					
2 #6 copper, 1 #8 copper	E4@.081	LF	2.93	4.16	7.09
3 #6 copper, 1 #8 copper	E4@.092	LF	3.62	4.72	8.34
5 #8 copper	E4@.100	LF	3.47	5.13	8.60
1-1/2" PVC conduit with wire					
4 #6 copper, 1 #8 copper	E4@.117	LF	5.06	6.01	11.07
2 #4 copper, 1 #8 copper	E4@.097	LF	4.10	4.98	9.08
2 #1 alum, 1 #8 copper	E4@.102	LF	4.33	5.24	9.57
3 #1 alum, 1 #8 copper	E4@.119	LF	5.34	6.11	11.45
4 #4 copper, 1 #8 copper	E4@.124	LF	5.89	6.37	12.26
3 #3 copper, 1 #8 copper	E4@.116	LF	6.00	5.96	11.96
4 #3 copper, 1 #8 copper	E4@.132	LF	7.23	6.78	14.01
2 #1 copper, 1 #8 copper	E4@.108	LF	7.22	5.54	12.76
3 #1 copper, 1 #8 copper	E4@.125	LF	9.68	6.42	16.10
4 #1 copper, 1 #8 copper	E4@.143	LF	12.10	7.34	19.44
2" PVC conduit with wire					
4 #1 alum, 1 #8 copper	E4@.154	LF	7.00	7.91	14.91
2 2/0 alum, 1 #6 copper	E4@.123	LF	6.09	6.31	12.40
3 2/0 alum, 1 #6 copper	E4@.143	LF	7.55	7.34	14.89
4 2/0 alum, 1 #6 copper	E4@.163	LF	9.01	8.37	17.38
2 3/0 alum, 1 #6 copper	E4@.127	LF	6.81	6.52	13.33
3 3/0 alum, 1 #6 copper	E4@.148	LF	8.63	7.60	16.23
4 3/0 alum, 1 #6 copper	E4@.171	LF	10.50	8.78	19.28
2 1/0 & 1 #6 copper	E4@.124	LF	5.65	6.37	12.02
3 1/0 & 1 #6 copper	E4@.146	LF	6.89	7.50	14.39
4 1/0 & 1 #6 copper	E4@.167	LF	8.13	8.57	16.70
2 3/0 & 1 #4 copper	E4@.136	LF	7.02	6.98	14.00
3 3/0 & 1 #4 copper	E4@.162	LF	8.84	8.32	17.16

26 Electrical

	Craft@Hrs	Unit	Material	Labor	Total
2-1/2" PVC conduit with wire					
2 250 MCM alum, 1 #4 copper	E4@.156	LF	9.89	8.01	17.90
3 250 MCM alum, 1 #4 copper	E4@.183	LF	12.40	9.40	21.80
4 3/0 alum, 1 #4 copper	E4@.206	LF	10.40	10.60	21.00
2 4/0 alum, 1 #2 copper	E4@.164	LF	9.50	8.42	17.92
3 4/0 alum, 1 #2 copper	E4@.193	LF	11.50	9.91	21.41
4 4/0 alum, 1 #2 copper	E4@.221	LF	13.50	11.30	24.80
2 250 MCM copper, 1 #2 copper	E4@.170	LF	16.40	8.73	25.13
3" PVC conduit with wire					
4 250 MCM alum, 1 #4 copper	E4@.226	LF	16.50	11.60	28.10
2 350 MCM alum, 1 #2 copper	E4@.186	LF	14.00	9.55	23.55
3 350 MCM alum, 1 #2 copper	E4@.217	LF	17.50	11.10	28.60
3 250 MCM alum, 1 #2 copper	E4@.217	LF	14.50	11.10	25.60
4 250 MCM alum, 1 #2 copper	E4@.248	LF	16.90	12.70	29.60
3-1/2" PVC conduit with wire					
4 350 MCM alum, 1 #2 copper	E4@.264	LF	21.30	13.60	34.90
4" PVC conduit with wire					
6 350 MCM alum, 1 #2 copper	E4@.293	LF	34.00	15.00	49.00
7 350 MCM alum, 1 #2 copper	E4@.391	LF	37.50	20.10	57.60
3 500 MCM alum, 1 1/0 copper	E4@.311	LF	27.80	16.00	43.80
4 500 MCM alum, 1 1/0 copper	E4@.355	LF	32.30	18.20	50.50
Flexible Aluminum Conduit Type RWA installed in a building to 10' above floor level. No wire, fittings or supports included.					
3/8" conduit	E4@.025	LF	.55	1.28	1.83
1/2" conduit	E4@.028	LF	.86	1.44	2.30
3/4" conduit	E4@.030	LF	.78	1.54	2.32
1" conduit	E4@.033	LF	1.74	1.69	3.43
1-1/4" conduit	E4@.035	LF	3.49	1.80	5.29
1-1/2" conduit	E4@.038	LF	3.22	1.95	5.17
2" conduit	E4@.040	LF	5.44	2.05	7.49
Flexible Steel Conduit installed in a building to 10' above floor level. No wire, fittings or supports included.					
3/8" conduit	E4@.025	LF	.70	1.28	1.98
1/2" conduit	E4@.028	LF	.70	1.44	2.14
3/4" conduit	E4@.030	LF	.99	1.54	2.53
1" conduit	E4@.033	LF	2.56	1.69	4.25
1-1/4" conduit	E4@.035	LF	2.33	1.80	4.13
1-1/2" conduit, 25' coil	E4@.038	LF	3.19	1.95	5.14
2" conduit	E4@.040	LF	4.79	2.05	6.84
90-degree flex screw-in connector					
3/8" connector	E4@.070	Ea	1.70	3.59	5.29
1/2" connector	E4@.086	Ea	2.36	4.42	6.78
3/4" connector	E4@.100	Ea	3.46	5.13	8.59
1" connector	E4@.113	Ea	4.32	5.80	10.12
1-1/4" connector	E4@.148	Ea	6.82	7.60	14.42
1-1/2" connector	E4@.191	Ea	10.60	9.81	20.41
2" connector	E4@.260	Ea	25.30	13.30	38.60
2-1/2" connector	E4@.326	Ea	117.00	16.70	133.70
3" connector	E4@.435	Ea	209.00	22.30	231.30
Add for insulated set-screw connector	—	%	100.0	—	—

26 Electrical

	Craft@Hrs	Unit	Material	Labor	Total
Flex screw-in coupling					
1/2" coupling	E4@.086	Ea	1.15	4.42	5.57
3/4" coupling	E4@.100	Ea	2.93	5.13	8.06
1" coupling	E4@.113	Ea	2.97	5.80	8.77
1-1/4" coupling	E4@.148	Ea	3.27	7.60	10.87
1-1/2" coupling	E4@.191	Ea	5.22	9.81	15.03
2" coupling	E4@.260	Ea	6.48	13.30	19.78
Add for height over 10' to 20'	—	%	—	20.0	—
Flexible Non-metallic Conduit, (ENT) blue conduit installed in a building to 10' above floor level. NER-290. No wire, fittings or supports included.					
1/2" conduit	E4@.021	LF	.78	1.08	1.86
3/4" conduit	E4@.022	LF	.70	1.13	1.83
1" conduit	E4@.030	LF	1.08	1.54	2.62
Liquid-Tight Flexible Metal Conduit, construction grade installed exposed in a building either vertically or horizontally up to 10' above floor level. No wire, fittings or supports included.					
3/8" conduit	E4@.045	LF	1.68	2.31	3.99
1/2" conduit	E4@.045	LF	1.41	2.31	3.72
3/4" conduit	E4@.047	LF	2.39	2.41	4.80
1" conduit	E4@.050	LF	4.17	2.57	6.74
1-1/4" conduit	E4@.055	LF	3.92	2.82	6.74
1-1/2" conduit	E4@.065	LF	6.04	3.34	9.38
2" conduit	E4@.070	LF	8.51	3.59	12.10
Liquid-Tight Flexible Metal Conduit, Type LT installed exposed in a building either vertically or horizontally up to 10' above floor level. No wire, fittings or supports included.					
3/8" conduit	E4@.045	LF	1.33	2.31	3.64
1/2" conduit	E4@.045	LF	1.59	2.31	3.90
3/4" conduit	E4@.047	LF	2.12	2.41	4.53
1" conduit	E4@.050	LF	3.23	2.57	5.80
1-1/4" conduit	E4@.055	LF	4.41	2.82	7.23
1-1/2" conduit	E4@.065	LF	5.97	3.34	9.31
2" conduit	E4@.070	LF	7.49	3.59	11.08
Liquid-tight straight flex connector, die cast					
1/2" connector	E4@.129	Ea	3.30	6.62	9.92
3/4" connector	E4@.140	Ea	4.61	7.19	11.80
1" connector	E4@.221	Ea	6.59	11.30	17.89
1-1/4" connector	E4@.244	Ea	7.84	12.50	20.34
1-1/2" connector	E4@.293	Ea	11.80	15.00	26.80
2" connector	E4@.492	Ea	18.80	25.30	44.10
90-degree liquid-tight flex connector, die cast					
1/2" connector	E4@.129	Ea	5.93	6.62	12.55
3/4" connector	E4@.140	Ea	8.34	7.19	15.53
1" connector	E4@.221	Ea	16.00	11.30	27.30
1-1/4" connector	E4@.244	Ea	25.60	12.50	38.10
1-1/2" connector	E4@.293	Ea	33.40	15.00	48.40
2" connector	E4@.492	Ea	58.70	25.30	84.00
Non-Metallic Liquid-Tight Flexible Conduit installed exposed in a building either vertically or horizontally up to 10' above floor level. No wire, fittings or supports included.					
3/8" conduit, 100-foot rolls	E4@.051	LF	.61	2.62	3.23
1/2" conduit, 100-foot rolls	E4@.051	LF	.59	2.62	3.21
3/4" conduit, 100-foot rolls	E4@.067	LF	.76	3.44	4.20
1" conduit, 100-foot rolls	E4@.067	LF	2.11	3.44	5.55
1-1/4" conduit, 100-foot rolls	E4@.085	LF	2.74	4.36	7.10
1-1/2" conduit, 50-foot rolls	E4@.085	LF	3.67	4.36	8.03
2" conduit, 50-foot rolls	E4@.105	LF	4.78	5.39	10.17

26 Electrical

	Craft@Hrs	Unit	Material	Labor	Total
Non-metallic liquid-tight flex connector					
1/2" zero to 90 degree connector	E4@.060	Ea	8.11	3.08	11.19
3/4" zero to 90 degree connector	E4@.070	Ea	8.52	3.59	12.11
1" zero to 90 degree connector	E4@.080	Ea	7.82	4.11	11.93
1-1/4" zero to 90 degree connector	E4@.100	Ea	16.70	5.13	21.83
1-1/2" zero to 90 degree connector	E4@.100	Ea	22.20	5.13	27.33
2" zero to 90 degree connector	E4@.140	Ea	38.10	7.19	45.29
1/2" 90 degree connector	E4@.060	Ea	7.48	3.08	10.56
3/4" 90 degree connector	E4@.070	Ea	10.70	3.59	14.29
1" 90 degree connector	E4@.080	Ea	24.50	4.11	28.61
1-1/4" 90 degree connector	E4@.100	Ea	29.70	5.13	34.83
1-1/2" 90 degree connector	E4@.100	Ea	38.10	5.13	43.23
2" 90 degree connector	E4@.140	Ea	54.80	7.19	61.99
Add for height over 10' to 20'	—	%	—	20.0	—

Conduit Supports and Hangers By conduit size. Installed exposed in a building to 10' above floor level. Hangers and supports installed at heights over 10' will add about 20% to the labor cost.

Right angle conduit supports

3/8" support	E4@.030	Ea	.47	1.54	2.01
1/2" support or 3/4" support	E4@.040	Ea	.47	2.05	2.52
1" support	E4@.050	Ea	.70	2.57	3.27
1-1/4" support	E4@.060	Ea	.78	3.08	3.86
1-1/2" support	E4@.060	Ea	.84	3.08	3.92
2" support	E4@.100	Ea	1.13	5.13	6.26
2-1/2" support	E4@.100	Ea	1.34	5.13	6.47
3" support	E4@.150	Ea	1.67	7.70	9.37
3-1/2" support	E4@.150	Ea	2.22	7.70	9.92
4" support	E4@.150	Ea	4.65	7.70	12.35
Add for parallel conduit supports	—	%	50.0	—	—
Add for edge conduit supports	—	%	120.0	—	—



Conduit hangers, rigid with bolt, labor includes the cost of cutting threaded rod to length and attaching the rod. Add the material cost of the threaded rod from below.

1/2" hanger	E4@.097	Ea	.80	4.98	5.78
3/4" hanger	E4@.097	Ea	.83	4.98	5.81
1" hanger	E4@.108	Ea	1.36	5.54	6.90
1-1/4" hanger	E4@.108	Ea	1.88	5.54	7.42
1-1/2" hanger	E4@.108	Ea	2.29	5.54	7.83
2" hanger	E4@.119	Ea	2.50	6.11	8.61
2-1/2" hanger	E4@.119	Ea	3.22	6.11	9.33
3" hanger	E4@.119	Ea	3.84	6.11	9.95
3-1/2" hanger	E4@.129	Ea	5.48	6.62	12.10
4" hanger	E4@.129	Ea	12.90	6.62	19.52



All threaded rod, plated steel, per linear foot of rod

1/4", 20 thread	—	LF	.69	—	.69
5/16", 18 thread	—	LF	.77	—	.77
3/8", 16 thread	—	LF	.88	—	.88
1/2", 13 thread	—	LF	1.13	—	1.13
5/8", 11 thread	—	LF	1.83	—	1.83
Deduct for plain steel rod	—	%	-10.0	—	—



Rod beam clamps, for 1/4" or 3/8" threaded rod

1" x 1" base, 15/16" jaw, 450 lb rating	E4@.200	Ea	2.68	10.30	12.98
2" x 2" base, 1" jaw, 1,300 lb rating	E4@.200	Ea	4.94	10.30	15.24
2-5/8" x 2-1/2" base, 1" jaw, 1,300 lb rating	E4@.234	Ea	6.85	12.00	18.85

26 Electrical

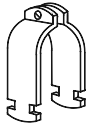
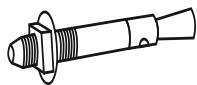
	Craft@Hrs	Unit	Material	Labor	Total
Conduit clamps for EMT conduit					
1/2" or 3/4" clamp	E4@.062	Ea	.25	3.18	3.43
1" clamp	E4@.069	Ea	.34	3.54	3.88
1-1/4" clamp	E4@.069	Ea	.50	3.54	4.04
1-1/2" clamp	E4@.069	Ea	.53	3.54	4.07
2" clamp	E4@.075	Ea	.60	3.85	4.45
					
One hole heavy-duty stamped steel conduit straps					
1/2" strap	E4@.039	Ea	.18	2.00	2.18
3/4" strap	E4@.039	Ea	.23	2.00	2.23
1" strap	E4@.039	Ea	.40	2.00	2.40
1-1/4" strap	E4@.039	Ea	.60	2.00	2.60
1-1/2" strap	E4@.039	Ea	.80	2.00	2.80
2" strap	E4@.039	Ea	1.04	2.00	3.04
2-1/2" strap	E4@.053	Ea	3.59	2.72	6.31
3" strap	E4@.053	Ea	5.01	2.72	7.73
3-1/2" strap	E4@.059	Ea	7.52	3.03	10.55
4" strap	E4@.059	Ea	7.79	3.03	10.82
Add for malleable iron one hole straps	—	%	30.0	—	—
Deduct for nail drive straps	—	%	-20.0	-30.0	—
Deduct for two hole stamped steel EMT straps	—	%	-70.0	—	—
Hanger channel, 1-5/8" x 1-5/8", based on 12" length					
No holes, solid back,					
12 gauge steel	E4@.119	Ea	4.37	6.11	10.48
Holes 1-1/2" on center,					
12 gauge aluminum	E4@.119	Ea	5.01	6.11	11.12
Channel strap for rigid steel conduit or EMT conduit, by conduit size, with bolts					
1/2" strap	E4@.020	Ea	1.26	1.03	2.29
3/4" strap	E4@.020	Ea	1.41	1.03	2.44
1" strap	E4@.023	Ea	1.51	1.18	2.69
1-1/4" strap	E4@.023	Ea	1.76	1.18	2.94
1-1/2" strap	E4@.023	Ea	1.98	1.18	3.16
2" strap	E4@.023	Ea	2.25	1.18	3.43
2-1/2" strap	E4@.039	Ea	2.46	2.00	4.46
3" strap	E4@.039	Ea	2.70	2.00	4.70
3-1/2" strap	E4@.039	Ea	3.30	2.00	5.30
4" strap	E4@.062	Ea	3.67	3.18	6.85
5" strap	E4@.062	Ea	4.52	3.18	7.70
6" strap	E4@.062	Ea	6.08	3.18	9.26
					
Lag screws, zinc plated, flattened end with stove bolt					
1/4" x 3"	E4@.092	Ea	.43	4.72	5.15
1/4" x 4"	E4@.092	Ea	.53	4.72	5.25
5/16" x 3-1/2"	E4@.092	Ea	.58	4.72	5.30
3/8" x 4"	E4@.119	Ea	.69	6.11	6.80
1/2" x 5"	E4@.129	Ea	1.36	6.62	7.98
Add for galvanized screws	—	%	100.0	—	—
Lag screw short expansion shields, without screws. Labor is for drilling hole					
1/4" or 5/16" x 1" shield	E4@.175	Ea	.61	8.98	9.59
3/8" x 1-3/4" shield	E4@.272	Ea	1.06	14.00	15.06
1/2" x 2" shield	E4@.321	Ea	1.42	16.50	17.92
5/8" x 2" shield	E4@.321	Ea	3.76	16.50	20.26
5/8" x 3-1/2" shield	E4@.345	Ea	5.67	17.70	23.37
					

26 Electrical

	Craft@Hrs	Unit	Material	Labor	Total
Self drilling masonry anchors					
1/4" anchor	E4@.127	Ea	.75	6.52	7.27
5/16" anchor	E4@.127	Ea	1.02	6.52	7.54
3/8" anchor	E4@.191	Ea	1.17	9.81	10.98
1/2" anchor	E4@.191	Ea	1.83	9.81	11.64
5/8" anchor	E4@.259	Ea	3.05	13.30	16.35
3/4" anchor	E4@.259	Ea	5.02	13.30	18.32
Wiremold Raceway Steel, one-piece, installed on a finished wall in a building. Raceway including one coupling each 10 feet					
V500 2 wire surface mounted raceway	E4@.059	LF	1.10	3.03	4.13
V700 2 wire surface mounted raceway	E4@.067	LF	1.98	3.44	5.42
Wiremold fittings					
V700 90-degree flat elbow	E4@.050	Ea	4.35	2.57	6.92
V700 90-degree twist elbow	E4@.050	Ea	5.88	2.57	8.45
V700 90-degree inside elbow	E4@.050	Ea	4.25	2.57	6.82
V700 90-degree outside elbow	E4@.050	Ea	4.84	2.57	7.41
V700 90-degree internal pull elbow	E4@.050	Ea	12.50	2.57	15.07
V700 90-degree internal twist elbow	E4@.150	Ea	4.44	7.70	12.14
V500 45-degree flat elbow	E4@.150	Ea	4.57	7.70	12.27
V500 90-degree flat elbow	E4@.150	Ea	2.29	7.70	9.99
V500/700 adjustable offset connector	E4@.150	Ea	9.16	7.70	16.86
V500 conduit connector	E4@.150	Ea	4.00	7.70	11.70
V700 connection cover	E4@.200	Ea	.45	10.30	10.75
V700 3-way branch "T"-fitting	E4@.100	Ea	6.15	5.13	11.28
V700 to 1/2" conduit transition fitting	E4@.050	Ea	6.98	2.57	9.55
V500/700 flexible section, 18"	E4@.350	Ea	17.90	18.00	35.90
V500/700 galvanized box connector	E4@.200	Ea	6.22	10.30	16.52
V500/700 coupling	E4@.200	Ea	.39	10.30	10.69
V500/700 support clip	—	Ea	.44	—	.44
Wiremold device box, V500/700 surface raceway					
1 gang, 1-3/8" diameter, 1 KO	E4@.250	Ea	7.56	12.80	20.36
1 gang, 2-1/4" diameter, 1 KO	E4@.250	Ea	16.50	12.80	29.30
1 gang, 4-5/8" x 2-7/8"	E4@.200	Ea	7.20	10.30	17.50
2 gang, 4-3/4" x 4-3/4"	E4@.300	Ea	13.00	15.40	28.40
2 gang, 15/16" diameter, 1 KO	E4@.300	Ea	5.90	15.40	21.30
2 gang, 1-3/4" diameter, 2 KO	E4@.300	Ea	15.70	15.40	31.10
2 gang, 2-1/4" diameter, 1 KO	E4@.300	Ea	20.70	15.40	36.10
Corner box, 2-1/2" diameter	E4@.250	Ea	16.50	12.80	29.30
Duplex receptacle box, 4-1/8" x 2" x 1-3/8"	E4@.360	Ea	24.10	18.50	42.60
Fixture box, 4-3/4" diameter	E4@.250	Ea	12.40	12.80	25.20
Fixture box, 6-3/8" diameter	E4@.250	Ea	14.50	12.80	27.30
Fixture box, 5-1/2" diameter	E4@.250	Ea	11.90	12.80	24.70
Junction and pull box, 1" x 5-1/2" diameter	E4@.250	Ea	12.00	12.80	24.80
Extension box, 4-3/4" diameter	E4@.250	Ea	11.60	12.80	24.40
Wiremold outlet box, V700 surface raceway					
Regular outlet box	E4@.250	Ea	7.67	12.80	20.47
Deep outlet box	E4@.250	Ea	9.24	12.80	22.04
Extra deep outlet box	E4@.250	Ea	9.35	12.80	22.15
Fan box	E4@.250	Ea	14.30	12.80	27.10
Starter box	E4@.250	Ea	7.68	12.80	20.48
Utility box, 2" x 4-1/8" x 1-3/8"	E4@.360	Ea	8.97	18.50	27.47

26 Electrical

	Craft@Hrs	Unit	Material	Labor	Total
Plugmould® V2000 multi-outlet raceway					
Entrance end fitting	E4@.100	Ea	5.64	5.13	10.77
6 outlets, 36" long	E4@.450	Ea	33.20	23.10	56.30
6 outlets, 40" long, w/ circuit breaker	E4@.450	Ea	44.50	23.10	67.60
8 outlets, 52" long	E4@.550	Ea	49.00	28.20	77.20
10 outlets, 60" long	E4@.650	Ea	38.70	33.40	72.10

Cable Tray and Duct

Cable tray, zinc-plated steel wire basket type. Mounted on walls or posts or suspended from the ceiling.

6" or 8" wide, 2" deep, straight tray	E4@.144	LF	4.93	7.39	12.32
12" wide, 2" deep, straight tray	E4@.187	LF	5.70	9.60	15.30
18" wide, 2" deep, straight tray	E4@.187	LF	6.06	9.60	15.66
24" wide, 2" deep, straight tray	E4@.238	LF	6.83	12.20	19.03
6" or 8" wide, 4" deep, straight tray	E4@.144	LF	5.72	7.39	13.11
12" wide, 4" deep, straight tray	E4@.187	LF	6.46	9.60	16.06
18" wide, 4" deep, straight tray	E4@.187	LF	7.47	9.60	17.07
24" wide, 4" deep, straight tray	E4@.238	LF	8.38	12.20	20.58
Add for each L or reducer section	E4@.476	Ea	39.40	24.40	63.80
Add for each T or X junction section	E4@.476	Ea	78.80	24.40	103.20
Steel underfloor duct, including typical supports, fittings and accessories					
3-1/4" wide, 1 cell	E4@.097	LF	8.84	4.98	13.82
3-1/4" wide, 2 cell	E4@.104	LF	18.00	5.34	23.34
7-1/4" wide, 1 cell	E4@.148	LF	20.90	7.60	28.50
7-1/4" wide, 2 cell	E4@.148	LF	31.80	7.60	39.40

Wire and Cable

Copper wire and cable prices can change very quickly. Quarterly price updates for *National Estimator* are free and automatic during the year of issue. You'll be prompted when it's time to collect the next update. A Web connection is required.

Service Entrance Cable 600 volt stranded service entrance. Full spool prices.

SEU copper service entrance cable. Pulled in conduit. No excavation or conduit included. Type XHHW wire wound in a concentrically applied neutral and jacketed with gray sunlight-resistant PVC.

10-10-10	E4@.012	LF	.94	.62	1.56
8-8-8	E4@.012	LF	1.13	.62	1.75
6-6-8	E4@.012	LF	1.93	.62	2.55
6-6-6	E4@.012	LF	2.72	.62	3.34
4-4-6	E4@.014	LF	3.24	.72	3.96
4-4-4	E4@.014	LF	4.04	.72	4.76
3-3-5	E4@.014	LF	4.17	.72	4.89
3-3-3	E4@.015	LF	4.49	.77	5.26
2-2-4	E4@.016	LF	4.50	.82	5.32
2-2-2	E4@.016	LF	5.19	.82	6.01
1-1-1	E4@.018	LF	7.19	.92	8.11
1/0-1/0-1/0	E4@.020	LF	8.90	1.03	9.93
2/0-2/0-2/0	E4@.022	LF	11.30	1.13	12.43
3/0-3/0-3/0	E4@.024	LF	14.00	1.23	15.23
4/0-4/0-4/0	E4@.026	LF	15.70	1.33	17.03

SER aluminum service entrance cable. Three stranded aluminum conductors with color-coded cross-linked polyethylene (XLPE) insulation, bare ground wire and PVC jacket. For above ground service entrance, panel feeder and branch circuits.

6 gauge, 3 conductors, 6 gauge ground, 60 amps	E4@.012	LF	.90	.62	1.52
4 gauge, 3 conductors, 6 gauge ground, 75 amps	E4@.014	LF	1.01	.72	1.73
2 gauge, 3 conductors, 4 gauge ground, 100 amps	E4@.016	LF	1.50	.82	2.32
1 gauge, 3 conductors, 2 gauge ground, 110 amps	E4@.018	LF	1.83	.92	2.75
1/0, 3 conductors, 2 gauge ground, 125 amps	E4@.020	LF	2.17	1.03	3.20
2/0, 3 conductors, 1 gauge ground, 150 amps	E4@.022	LF	2.61	1.13	3.74
3/0, 3 conductors, 1/0 ground, 175 amps	E4@.024	LF	3.27	1.23	4.50
4/0, 3 conductors, 2/0 ground, 200 amps	E4@.026	LF	3.70	1.33	5.03

26 Electrical

	Craft@Hrs	Unit	Material	Labor	Total
USE underground service entrance wire. Stranded conductor insulated with abrasion, heat, moisture, and sunlight-resistant cross-linked polyethylene (XLP). General purpose wire, including conduit, direct burial and overhead.					
8 gauge, copper	E4@.009	LF	.93	.46	1.39
6 gauge, copper	E4@.010	LF	1.33	.51	1.84
2 gauge, copper	E4@.016	LF	3.10	.82	3.92
1/0 gauge, copper	E4@.017	LF	4.44	.87	5.31
2/0 gauge, copper	E4@.018	LF	5.50	.92	6.42
4/0 gauge, copper	E4@.018	LF	8.30	.92	9.22
250 MCM, copper	E4@.020	LF	8.88	1.03	9.91
500 MCM, copper	E4@.022	LF	16.10	1.13	17.23
Deduct for aluminum USE service entrance wire	—	%	-60.0	—	—
URD triplex aluminum service entrance cable. For direct burial or installation in ducts, in either wet or dry locations.					
6 gauge, Erskine	E4@.011	LF	1.03	.56	1.59
4 gauge, Vassar	E4@.012	LF	1.03	.62	1.65
2 gauge, Ramapo	E4@.013	LF	1.36	.67	2.03
2/0 gauge, Converse	E4@.017	LF	1.84	.87	2.71
4/0 gauge, Monmouth	E4@.020	LF	2.97	1.03	4.00
Bare Copper Ground Wire Pulled in conduit with conductor wires. No excavation or duct included. By American Wire Gauge. Cost based upon 1,000' reels. For cut-to-length prices, add 100% to the material cost.					
12 gauge, solid, 1,000' reel	E4@.004	LF	.26	.21	.47
10 gauge, solid, 1,000' reel	E4@.005	LF	.34	.26	.60
8 gauge, solid, 1,000' reel	E4@.005	LF	.54	.26	.80
6 gauge, solid, 1,000' reel	E4@.005	LF	.85	.26	1.11
4 gauge, solid, 1,000' reel	E4@.006	LF	1.29	.31	1.60
4 gauge, stranded, 1,000' reel	E4@.006	LF	1.37	.31	1.68
2 gauge, solid, 1,000' reel	E4@.008	LF	1.89	.41	2.30
2 gauge, stranded, 1,000' reel	E4@.008	LF	2.24	.41	2.65
THHN/THWN-2 Copper Building Wire Pulled in conduit for feeder and branch circuits. No conduit included. THHN has a heat-resistant thermoplastic cover approved for working temperatures up to 90 degrees Celsius in dry locations. THWN resists moisture, oil and gasoline and is approved for temperatures to 75 degrees Celsius in dry, wet or oil locations. THHN/THWN is made from soft annealed copper and insulated with heat- and moisture-resistant PVC and covered with nylon (polyamide). Available in colors to simplify identification of conductors after wire is pulled in conduit. By American Wire Gauge (AWG). Stranded wire has 19 strands. Cost based on 1,000' reels. For cut-to-length prices, add 100% to the material cost. Copper wire prices are highly volatile.					
14 gauge, solid, 1,000' reel	E4@.006	LF	.12	.31	.43
14 gauge, stranded, 1,000' reel	E4@.006	LF	.13	.31	.44
12 gauge, solid, 1,000' reel	E4@.007	LF	.22	.36	.58
12 gauge, stranded, 1,000' reel	E4@.007	LF	.24	.36	.60
10 gauge, solid, 1,000' reel	E4@.008	LF	.25	.41	.66
10 gauge, stranded, 1,000' reel	E4@.008	LF	.27	.41	.68
8 gauge, stranded, 1,000' reel	E4@.009	LF	.48	.46	.94
6 gauge, stranded, 1,000' reel	E4@.010	LF	.69	.51	1.20
4 gauge, stranded, 1,000' reel	E4@.012	LF	.88	.62	1.50
3 gauge, stranded, 1,000' reel	E4@.013	LF	1.23	.67	1.90
2 gauge, stranded, 1,000' reel	E4@.013	LF	1.32	.67	1.99
1 gauge, stranded, 1,000' reel	E4@.014	LF	2.46	.72	3.18
1/0 gauge, stranded, 1,000' reel	E4@.015	LF	2.44	.77	3.21
2/0 gauge, stranded, 1,000' reel	E4@.016	LF	6.51	.82	7.33
3/0 gauge, stranded, 1,000' reel	E4@.017	LF	3.48	.87	4.35
4/0 gauge, stranded, 1,000' reel	E4@.018	LF	4.37	.92	5.29
250 MCM, stranded, 1,000' reel	E4@.020	LF	5.48	1.03	6.51
350 MCM, stranded, 1,000' reel	E4@.038	LF	7.00	1.95	8.95
500 MCM, stranded, 1,000' reel	E4@.046	LF	10.20	2.36	12.56

26 Electrical

Craft@Hrs Unit Material Labor Total

XHHW Copper Building Wire Pulled in conduit for feeder and branch circuits. No conduit included. Abrasion-, moisture- and heat-resistant thermoplastic intended for harsh environments. Maximum operating temperature is 90 degrees Celsius in dry locations and 75 degrees Celsius in wet locations. Flame-retardant cross-linked synthetic polymer insulation. XHHW has no outer jacket or covering. Available in colors to simplify identification of conductors after wire is pulled in conduit. By American Wire Gauge (AWG). Stranded wire has 19 strands. Cost based on 1,000' reels. For cut-to-length prices, add 100% to the material cost. Copper wire prices are highly volatile.

14 gauge, stranded	E4@.006	LF	.22	.31	.53
12 gauge, stranded	E4@.007	LF	.31	.36	.67
10 gauge, solid	E4@.008	LF	.41	.41	.82
8 gauge, stranded	E4@.009	LF	.79	.46	1.25
6 gauge, stranded	E4@.010	LF	1.19	.51	1.70
4 gauge, stranded	E4@.012	LF	1.76	.62	2.38
3 gauge, stranded	E4@.013	LF	2.16	.67	2.83
2 gauge, stranded	E4@.014	LF	2.71	.72	3.43
1 gauge, stranded	E4@.015	LF	3.01	.77	3.78
1/0 gauge, stranded	E4@.016	LF	3.76	.82	4.58
2/0 gauge, stranded	E4@.017	LF	4.68	.87	5.55
4/0 gauge, stranded	E4@.018	LF	7.30	.92	8.22
250 MCM, stranded	E4@.020	LF	8.12	1.03	9.15

Type UF-B Direct Burial Sheathed Cable Installed in an open trench. No excavation or backfill included. UF-B is designed for burial in a trench but may also be used to wire interior branch circuits in residential and agricultural buildings. The cable jacket is sunlight-, fungus- and moisture-resistant gray PVC. Full-size ground wire. Full coil quantities. Copper wire prices are highly volatile.

14 gauge, 2 conductor	E4@.005	LF	.58	.26	.84
14 gauge, 3 conductor	E4@.005	LF	.86	.26	1.12
12 gauge, 2 conductor	E4@.005	LF	.96	.26	1.22
12 gauge, 3 conductor	E4@.005	LF	1.29	.26	1.55
10 gauge, 2 conductor	E4@.005	LF	1.50	.26	1.76
10 gauge, 3 conductor	E4@.006	LF	2.03	.31	2.34
8 gauge, 2 conductor	E4@.007	LF	2.60	.36	2.96
8 gauge, 3 conductor	E4@.007	LF	3.84	.36	4.20
6 gauge, 2 conductor	E4@.008	LF	3.64	.41	4.05
6 gauge, 3 conductor	E4@.008	LF	5.61	.41	6.02
Add for cut length quantities	—	%	20.0	—	—

Type NM-B (Romex) Sheathed Cable Installed in wood frame walls for outlets and switched fixtures, including boring out and pulling cable. NM-B cable can also be run through voids in masonry block or tile walls if little moisture is expected. Conductor insulation is color-coded PVC. 14 AWG (American Wire Gauge) is white, 12 AWG is yellow, 10 AWG is orange, and 8 and 6 AWG are black. Rated at 15 amps. With full-size ground wire. Full coil prices.

14 gauge, 2 conductor	E4@.027	LF	.94	1.39	2.33
14 gauge, 3 conductor	E4@.030	LF	1.25	1.54	2.79
12 gauge, 2 conductor	E4@.030	LF	1.26	1.54	2.80
12 gauge, 3 conductor	E4@.031	LF	2.25	1.59	3.84
10 gauge, 2 conductor	E4@.031	LF	2.09	1.59	3.68
10 gauge, 3 conductor	E4@.035	LF	1.60	1.80	3.40
8 gauge, 2 conductor	E4@.040	LF	2.88	2.05	4.93
8 gauge, 3 conductor	E4@.043	LF	3.04	2.21	5.25
6 gauge, 2 conductor	E4@.043	LF	4.05	2.21	6.26
6 gauge, 3 conductor	E4@.047	LF	5.82	2.41	8.23
4 gauge, 3 conductor	E4@.051	LF	11.70	2.62	14.32
2 gauge, 3 conductor	E4@.056	LF	19.10	2.88	21.98
Add for cut coil quantities	—	%	20.0	—	—
Deduct for no ground wire, #14 and #12 cable	—	%	-5.0	-5.0	—
Deduct for no ground wire, #10, #8 and #6 wire	—	%	-15.0	-5.0	—

26 Electrical

Craft@Hrs Unit Material Labor Total

MC Aluminum-Clad Copper Cable For use in dry sites. Exposed, concealed, or in approved raceway. Open or messenger-supported aerial runs. For powering lighting, control and signal circuits. Includes neutral, ground and one or two phase conductors. Installed with clamps or staples in a frame building or embedded in masonry, including approved bushings at terminations. Full coil prices.

14 gauge, 2 conductor	E4@.009	LF	.76	.46	1.22
14 gauge, 3 conductor	E4@.010	LF	1.26	.51	1.77
14 gauge, 4 conductor	E4@.011	LF	1.76	.56	2.32
12 gauge, 2 conductor	E4@.010	LF	1.01	.51	1.52
12 gauge, 3 conductor	E4@.011	LF	1.48	.56	2.04
12 gauge, 4 conductor	E4@.012	LF	2.12	.62	2.74
10 gauge, 2 conductor	E4@.011	LF	1.72	.56	2.28
10 gauge, 3 conductor	E4@.012	LF	3.32	.62	3.94
10 gauge, 4 conductor	E4@.013	LF	3.70	.67	4.37

Flexible Armored AC Cable, galvanized steel, 16 gauge integral bond wire to armor grounding path. Paper wrap conductor insulation covering. By American Wire Gauge and number of conductors. Installed exposed in a building either vertically or horizontally up to 10' above floor level. Sometimes referred to as "BX" cable.

#14 wire, 2 conductor	E4@.030	LF	.78	1.54	2.32
#14 wire, 3 conductor	E4@.030	LF	1.23	1.54	2.77
#12 wire, 2 conductor	E4@.030	LF	.61	1.54	2.15
#12 wire, 3 conductor	E4@.035	LF	.95	1.80	2.75
#12 wire, 4 conductor	E4@.038	LF	1.54	1.95	3.49
#10 wire, 2 conductor	E4@.031	LF	1.36	1.59	2.95
#10 wire, 3 conductor	E4@.039	LF	1.94	2.00	3.94
# 6 wire, 3 conductor	E4@.047	LF	5.09	2.41	7.50
# 4 wire, 3 conductor	E4@.051	LF	7.34	2.62	9.96
# 2 wire, 3 conductor	E4@.056	LF	10.50	2.88	13.38

Power Cable Single conductor medium voltage ozone-resistant stranded copper cable pulled in conduit. No conduit included. Labor cost assumes three bundled conductors are pulled at one time on runs up to 100 feet. Labor cost will be higher on longer cable pulls and about 50% lower when cable is laid in an open trench. No splicing included. Listed by American Wire Gauge. Note that wire prices can change very quickly. Check with supplier.

5,000 volt, tape shielded, crosslinked polyethylene (XLP) insulated, with PVC jacket

#6 gauge	E4@.014	LF	7.20	.72	7.92
#4 gauge	E4@.016	LF	7.50	.82	8.32
#2 gauge	E4@.021	LF	7.81	1.08	8.89
#1/0 gauge	E4@.026	LF	13.60	1.33	14.93
#2/0 gauge	E4@.028	LF	19.50	1.44	20.94
#4/0 gauge	E4@.038	LF	22.90	1.95	24.85
350 MCM	E4@.047	LF	34.10	2.41	36.51
500 MCM	E4@.053	LF	45.40	2.72	48.12

15,000 volt, tape shielded, ethylene propylene rubber (EPR) insulated, with PVC jacket

#2 gauge	E4@.024	LF	15.90	1.23	17.13
#1/0	E4@.030	LF	20.10	1.54	21.64
#2/0	E4@.032	LF	23.70	1.64	25.34
350 MCM	E4@.055	LF	47.30	2.82	50.12
500 MCM	E4@.062	LF	47.80	3.18	50.98

26 Electrical

Craft@Hrs Unit Material Labor Total

Snow-Melting Cable For concrete pavement. Self-regulating heater cable 208-277 volt AC, encased in concrete pavement for walkways, steps, loading ramps or parking garages. Based on Raychem ElectroMelt™ System for concrete pavement. Cable is cut to length at the site and laid in a serpentine pattern using 12-inch center-to-center spacing. Use nylon cable ties to fasten cable to the top of reinforcing before concrete is placed. For scheduling purposes estimate that a crew of one can lay out, cut to length, install and tie 600 LF of cable in an 8-hour day. Based on 1.1 LF of cable per SF of pavement, including ties, "return bends" and waste, this yields 545 SF of pavement. These costs do not include reinforcing, concrete or concrete placing. A rule of thumb for sizing circuit breakers: For startup at 0 degrees F with 220 volts AC, allow 0.20 amps per LF of cable.

Heater cable (1.1 LF per SF of pavement)	CE@.015	SF	11.70	.92	12.62
Power connection kit, including end seals	CE@.500	Ea	36.40	30.50	66.90
Cable expansion joint kit	CE@.250	Ea	27.90	15.30	43.20
ElectroMelt™ junction box	CE@.500	Ea	138.00	30.50	168.50
System controller, automatic	CE@1.50	Ea	2,910.00	91.50	3,001.50
Thermostat, line sensing	CE@.500	Ea	297.00	30.50	327.50
Ground fault protection device	CE@.969	Ea	440.00	59.10	499.10

Ice-Melting Cable For roofs, gutters and downspouts. Self-regulating heater cable 120 or 208-277 volts AC, run exposed on the surface of the roof or within gutters. Based on Raychem IceStop™ System for roofs and gutters. Cable is cut to length on site and laid in a serpentine pattern using 24-inch center-to-center spacing and 32-inch loop height. Fasten to the roof with Raychem clips. For scheduling purposes estimate that a crew of one can cut to length and install 400 LF of cable in an 8-hour day. Based on 1.2 LF of cable per SF of protected roof area, including clips, "return bends" and waste, this yields 330 SF of protected area. Figure each LF of gutter as equal to one SF of roof. Figure each downspout as equal to 15 SF of roof. These costs do not include the roofing, gutters, or downspouts. A rule of thumb for sizing circuit breakers: For startup at 0 degrees F with 120 volts AC, allow 0.17 amps per LF of cable. For startup at 0 degrees F with 208-277 volts AC, allow 0.11 amps per LF of cable.

Heater cable (1.2 LF per SF of protected area)	CE@.033	LF	7.03	2.01	9.04
Power connection kit	CE@.500	Ea	36.40	30.50	66.90
Cable splice kit	CE@.374	Ea	18.70	22.80	41.50
End seal kit	CE@.374	Ea	15.70	22.80	38.50
Downspout hanger	CE@.374	Ea	30.30	22.80	53.10
Metal roof mounting kit	CE@.500	Ea	30.20	30.50	60.70

Electrical Outlet Boxes Steel boxes installed on an exposed wall or ceiling. The material cost for phenolic, PVC and fiberglass boxes will be 50% to 70% less. These costs include fasteners but no switch or receptacle

Square outlet boxes

4" x 4" x 1-1/2" deep with
1/2" and 3/4" knockouts
Side mounting bracket

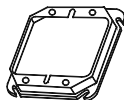

E4@.187	Ea	2.16	9.60	11.76
E4@.187	Ea	3.17	9.60	12.77

4" x 4" x 2-1/8" deep with
1/2" and 3/4" knockouts
Side mounting bracket

E4@.245	Ea	2.97	12.60	15.57
E4@.245	Ea	1.34	12.60	13.94

Add for

1-1/2" deep extension rings
Romex or BX clamps
Steel flush cover blanks
Plaster rings to 3/4" deep

E4@.120	Ea	2.21	6.16	8.37
—	Ea	1.04	—	1.04
E4@.039	Ea	.65	2.00	2.65
E4@.080	Ea	1.93	4.11	6.04

Octagon outlet boxes

4" x 1-1/2" deep with
1/2" knockouts
Mounting bracket, horizontal



E4@.187	Ea	1.29	9.60	10.89
E4@.187	Ea	2.38	9.60	11.98

4" x 2-1/8" deep with
1/2" and 3/4" knockouts

E4@.245	Ea	5.20	12.60	17.80
---------	----	------	-------	-------

26 Electrical

	Craft@Hrs	Unit	Material	Labor	Total
Add for					
1-1/2" deep extension rings	E4@.120	Ea	2.60	6.16	8.76
1-1/2" with 18.5" adjustable bar set	E4@.282	Ea	3.06	14.50	17.56
3" deep concrete ring	E4@.516	Ea	2.22	26.50	28.72
4" steel flush cover blanks	E4@.039	Ea	1.04	2.00	3.04
Plaster ring to 3/4" deep	E4@.080	Ea	2.00	4.11	6.11
Handy boxes, 4" x 2-1/8"					
1-1/2" deep, 1/2" knockouts	E4@.187	Ea	2.38	9.60	11.98
1-7/8" deep, 3/4" knockouts	E4@.187	Ea	1.04	9.60	10.64
2-1/2" deep, 3/4" knockouts	E4@.245	Ea	2.97	12.60	15.57
2-1/8" deep, with side mounting bracket	E4@.245	Ea	2.95	12.60	15.55
1-1/2" deep extension rings	E4@.120	Ea	3.79	6.16	9.95
Blank or switch cover	E4@.039	Ea	1.02	2.00	3.02
Weatherproof box and cover	E4@.059	Ea	4.34	3.03	7.37
Switch boxes, 3" x 2", square corner gangable boxes with mounting ears					
2" deep, 1/2" knockouts	E4@.245	Ea	1.95	12.60	14.55
2-1/2" deep, 1/2" knockouts	E4@.245	Ea	7.97	12.60	20.57
3-1/2" deep, 3/4" knockouts	E4@.324	Ea	5.36	16.60	21.96
Gang switch boxes, 2" x 3" x 1-5/8"					
2 gang	E4@.242	Ea	6.32	12.40	18.72
3 gang	E4@.342	Ea	9.92	17.60	27.52
4 gang	E4@.342	Ea	12.80	17.60	30.40
5 gang	E4@.482	Ea	21.70	24.70	46.40
6 gang	E4@.482	Ea	15.20	24.70	39.90
Floor boxes, watertight, cast iron, round					
4-3/16" x 3-3/4" deep, non-adjustable	E4@1.54	Ea	69.20	79.10	148.30
3-3/4" x 2" deep, semi-adjustable	E4@1.54	Ea	80.60	79.10	159.70
4-3/16" x 3-3/4" deep, adjustable	E4@1.54	Ea	95.90	79.10	175.00
2-1/8" single, round floor cover plates	E4@.156	Ea	45.10	8.01	53.11
Galvanized or gray enamel NEMA Class 1 (indoor) pull boxes, with screw cover, 4" deep					
4" x 4"	E4@.373	Ea	13.50	19.10	32.60
4" x 6"	E4@.373	Ea	16.10	19.10	35.20
6" x 6"	E4@.373	Ea	20.20	19.10	39.30
6" x 8"	E4@.391	Ea	22.10	20.10	42.20
8" x 8"	E4@.391	Ea	24.20	20.10	44.30
8" x 10"	E4@.444	Ea	29.70	22.80	52.50
8" x 12"	E4@.483	Ea	28.80	24.80	53.60
10" x 10"	E4@.492	Ea	27.10	25.30	52.40
10" x 12"	E4@.539	Ea	50.70	27.70	78.40
12" x 12"	E4@.593	Ea	57.20	30.40	87.60
12" x 16"	E4@.663	Ea	80.10	34.00	114.10
12" x 18"	E4@.785	Ea	83.40	40.30	123.70
Galvanized or gray enamel NEMA Class 1 (indoor) pull boxes, with screw cover, 6" deep					
6" x 6"	E4@.373	Ea	19.00	19.10	38.10
8" x 8"	E4@.391	Ea	26.20	20.10	46.30
8" x 10"	E4@.444	Ea	29.40	22.80	52.20
10" x 10"	E4@.492	Ea	34.80	25.30	60.10
10" x 12"	E4@.539	Ea	39.80	27.70	67.50
12" x 12"	E4@.593	Ea	49.80	30.40	80.20
12" x 16"	E4@.663	Ea	58.80	34.00	92.80

26 Electrical

	Craft@Hrs	Unit	Material	Labor	Total
12" x 18"	E4@.785	Ea	63.60	40.30	103.90
16" x 16"	E4@.929	Ea	72.00	47.70	119.70
18" x 18"	E4@1.10	Ea	78.00	56.50	134.50
18" x 24"	E4@1.30	Ea	142.00	66.70	208.70
24" x 24"	E4@1.54	Ea	178.00	79.10	257.10
Cast aluminum NEMA Class 3R (weatherproof) screw cover junction boxes, recessed, flush mounted, with cover					
6" x 6" x 4" deep	E4@.930	Ea	355.00	47.70	402.70
6" x 8" x 4" deep	E4@.930	Ea	438.00	47.70	485.70
6" x 6" x 6" deep	E4@.930	Ea	438.00	47.70	485.70
6" x 12" x 6" deep	E4@1.42	Ea	651.00	72.90	723.90
8" x 8" x 4" deep	E4@.982	Ea	499.00	50.40	549.40
8" x 8" x 6" deep	E4@1.14	Ea	536.00	58.50	594.50
8" x 12" x 6" deep	E4@1.30	Ea	811.00	66.70	877.70
10" x 10" x 6" deep	E4@1.33	Ea	459.00	68.30	527.30
12" x 12" x 6" deep	E4@1.35	Ea	963.00	69.30	1,032.30
12" x 12" x 8" deep	E4@1.73	Ea	1,130.00	88.80	1,218.80
12" x 24" x 6" deep	E4@1.97	Ea	2,150.00	101.00	2,251.00
18" x 36" x 8" deep	E4@2.56	Ea	4,980.00	131.00	5,111.00
Hinged cover panel enclosures, NEMA 1, enamel, with cover					
16" x 12" x 7" deep	E4@1.30	Ea	192.00	66.70	258.70
20" x 20" x 7" deep	E4@1.30	Ea	263.00	66.70	329.70
30" x 20" x 7" deep	E4@1.77	Ea	279.00	90.90	369.90
24" x 20" x 9" deep	E4@1.30	Ea	326.00	66.70	392.70
30" x 24" x 9" deep	E4@1.77	Ea	372.00	90.90	462.90
36" x 30" x 9" deep	E4@1.77	Ea	464.00	90.90	554.90
Electrical Receptacles					
Standard commercial grade except where noted. Ivory or brown receptacles. White or gray receptacles will cost about 10% more. Labor includes connecting wire and securing the device in the box. Add the cost of the box and the cover plate.					
15 amp, 125 volt self-grounding, 2 pole, 3 wire duplex receptacles					
Residential grade, grounded duplex	CE@.162	Ea	.52	9.88	10.40
Screwless, not self-grounding	CE@.162	Ea	2.75	9.88	12.63
Side terminals	CE@.162	Ea	2.75	9.88	12.63
Back and side terminals	CE@.162	Ea	2.74	9.88	12.62
Feed thru wiring, back and side terminals	CE@.162	Ea	6.34	9.88	16.22
Safety ground, side terminals	CE@.162	Ea	10.10	9.88	19.98
Ground fault circuit interrupter receptacle	CE@.324	Ea	16.40	19.80	36.20
Add for NEMA 5 single receptacles	—	%	15.0	—	—
20 amp, 125 volt self-grounding, 2 pole, 3 wire duplex receptacles					
Side terminals	CE@.162	Ea	7.25	9.88	17.13
Back and side terminals	CE@.162	Ea	10.40	9.88	20.28
Feed thru wiring, back and side terminals	CE@.162	Ea	10.80	9.88	20.68
Hospital grade	CE@.162	Ea	11.30	9.88	21.18
Ground fault circuit interrupter receptacle	CE@.324	Ea	18.50	19.80	38.30
Add for NEMA 5 single receptacles	—	%	15.0	—	—
15 amp, 125 volt self-grounding, 2 pole, 3 wire receptacles with USB ports					
1 receptacle, 2 USB ports	CE@.162	Ea	10.20	9.88	20.08
2 receptacles, 2 USB ports	CE@.162	Ea	20.80	9.88	30.68
2 receptacles, 2 USB ports, 20 amp	CE@.162	Ea	26.60	9.88	36.48
4.2 amp, 4 USB ports only	CE@.162	Ea	26.70	9.88	36.58
250 volt receptacles, self-grounding, 2 pole, 3 wire, back & side terminals					
15 amp, duplex	CE@.187	Ea	12.50	11.40	23.90
15 amp, single	CE@.187	Ea	8.67	11.40	20.07
20 amp, duplex	CE@.187	Ea	9.74	11.40	21.14
20 amp, duplex, feed thru wiring	CE@.187	Ea	15.40	11.40	26.80
20 amp, single	CE@.187	Ea	10.40	11.40	21.80

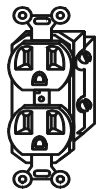

26 Electrical

	Craft@Hrs	Unit	Material	Labor	Total
Clock receptacle, 2 pole, 15 amp, 125 volt	CE@.329	Ea	7.34	20.10	27.44
120/208 volt 20 amp 4 pole, duplex receptacle	CE@.795	Ea	33.90	48.50	82.40
125/250 volt 3 pole receptacles, flush mount					
15 amp/10 amp	CE@.714	Ea	16.80	43.60	60.40
20 amp	CE@.820	Ea	40.10	50.00	90.10
30 amp	CE@.820	Ea	92.00	50.00	142.00
277 volt 30 amp 2 pole receptacle	CE@.268	Ea	53.80	16.40	70.20
Dryer receptacles, 250 volt, 30/50 amp, 3 wire	CE@.536	Ea	9.23	32.70	41.93
Accessories for 50 amp dryer receptacles					
Flush mounted plug	CE@.288	Ea	53.80	17.60	71.40
Surface mounted plug	CE@.288	Ea	36.80	17.60	54.40
Cord sets for dryer receptacles					
36 inch, three #10 wires	CE@.288	Ea	22.50	17.60	40.10
48 inch, three #10 wires	CE@.288	Ea	25.50	17.60	43.10
60 inch, three #10 wires	CE@.288	Ea	29.50	17.60	47.10
Electrical Switches Commercial grade, 120 to 277 volt rating except where noted. Ivory or brown. Add 10% for white or gray. Labor includes connecting wire to the switch and securing the switch in the box. Add the cost of the box and cover plate.					
15 amp switches, back and side wired					
One pole quiet switch, residential (side wired only)	CE@.112	Ea	.70	6.83	7.53
One pole switch, commercial, minimum quality	CE@.112	Ea	1.33	6.83	8.16
Two pole switch	CE@.309	Ea	12.40	18.90	31.30
Three-way switch	CE@.309	Ea	7.80	18.90	26.70
Four-way switch	CE@.309	Ea	10.30	18.90	29.20
20 amp switches, back and side wired					
One pole switch	CE@.187	Ea	3.09	11.40	14.49
Two pole switch	CE@.433	Ea	6.17	26.40	32.57
Three-way switch	CE@.291	Ea	5.13	17.80	22.93
Four-way switch	CE@.435	Ea	12.60	26.50	39.10
30 amp switches, side wired					
One pole switch	CE@.246	Ea	13.90	15.00	28.90
Two pole switch	CE@.475	Ea	20.70	29.00	49.70
Three-way switch	CE@.372	Ea	20.20	22.70	42.90
Four-way switch	CE@.475	Ea	30.10	29.00	59.10
20 amp weatherproof switches, lever handle, with cover					
One pole switch	CE@.187	Ea	10.10	11.40	21.50
Two pole switch	CE@.433	Ea	19.40	26.40	45.80
Three-way switch	CE@.291	Ea	13.30	17.80	31.10
Single pole, two gang, 10 amp	CE@.358	Ea	22.80	21.80	44.60
Dimmer switches, push for off					
Incandescent, 600 watt, one pole	CE@.417	Ea	11.30	25.40	36.70
LED or incandescent, single or three-way	CE@.626	Ea	33.90	38.20	72.10
Smart lighting, LED/CFL or incandescent/halogen	CE@.626	Ea	56.80	38.20	95.00
Fluorescent dimmer, 10 lamp load	CE@.626	Ea	58.60	38.20	96.80
Astro dial time switch, 40 amp, with box	CE@3.00	Ea	122.00	183.00	305.00
15 minute timer switch, wall box mounted	CE@.426	Ea	53.70	26.00	79.70
Single pole, 1 throw time switch, 277 volt	CE@.890	Ea	56.60	54.30	110.90
Float switches for sump pumps, automatic 10A, 125/250/480 VAC	CE@1.03	Ea	38.20	62.80	101.00

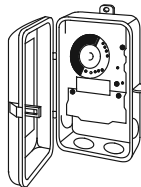

26 Electrical

	Craft@Hrs	Unit	Material	Labor	Total
One-way 15 amp toggle switch with neon pilot	CE@.327	Ea	8.23	20.00	28.23
Three-way 15 amp toggle switch with neon pilot	CE@.372	Ea	12.40	22.70	35.10
Photoelectric switches, flush, with wall plate					
120 volt, 1,000 watt	CE@.426	Ea	8.50	26.00	34.50
208 volt, 1,800 watt	CE@.626	Ea	10.00	38.20	48.20
480 volt, 3,000 watt	CE@.795	Ea	14.00	48.50	62.50
Button control stations, surface mounted, NEMA Class 1, standard duty, 120/240 volt, with enclosure					
Start-stop switch, 2 button	CE@.624	Ea	26.50	38.10	64.60
Start-stop switch with lockout, 2 button	CE@.624	Ea	39.70	38.10	77.80
Forward, reverse and stop buttons, 3 button	CE@.624	Ea	53.70	38.10	91.80
Forward, reverse, stop and lockout, 3 button	CE@.624	Ea	54.00	38.10	92.10
Manual toggle starter switches, surface mounted, NEMA Class 1, 120/240 volt, non-reversing, with enclosure					
Size 0 motors, 2 pole	CE@.613	Ea	108.00	37.40	145.40
Size 1 motors, 3 pole	CE@.698	Ea	139.00	42.60	181.60
Size 1-1/2 motors, 2 pole	CE@.901	Ea	159.00	55.00	214.00
Manual button starter switches, surface mounted, NEMA Class 1, 110 to 240 volt, 2 pole, 1 phase, with enclosure, start, stop, reset, with relay					
Size 00 motors	CE@.712	Ea	144.00	43.40	187.40
Size 0 motors	CE@.712	Ea	155.00	43.40	198.40
Size 1 motors	CE@.820	Ea	175.00	50.00	225.00
Size 1-1/2 motors	CE@.975	Ea	209.00	59.50	268.50
Electrical Box Cover Plates Includes the cover plate and screws. Add the cost of the box and switch or receptacle. Labor includes attaching the cover plate to the box. Almond or ivory plastic except as noted.					
Residential grade electrical box cover plates					
1 gang plate, duplex receptacle	CE@.050	Ea	.40	3.05	3.45
1 gang plate, toggle switch	CE@.050	Ea	.40	3.05	3.45
2 gang plate, 2 duplex receptacles	CE@.100	Ea	1.15	6.10	7.25
2 gang plate, two toggle switches	CE@.100	Ea	1.15	6.10	7.25
2 gang plate, oversize, toggle or receptacle	CE@.100	Ea	1.24	6.10	7.34
3 gang plate, toggle or receptacle	CE@.150	Ea	2.54	9.15	11.69
Decora multi-gang sectional plate, end or center	CE@.050	Ea	2.07	3.05	5.12
Stainless steel electrical box cover plates					
1 gang plate, blank, duplex or toggle	CE@.050	Ea	1.77	3.05	4.82
1 gang plate, power outlet	CE@.050	Ea	2.08	3.05	5.13
2 gang plate, blank, duplex or toggle	CE@.100	Ea	3.13	6.10	9.23
3 gang plate, blank, duplex or toggle	CE@.150	Ea	3.95	9.15	13.10
Specification grade electrical box cover plates					
1 gang plate, single receptacle or toggle switch	CE@.050	Ea	5.88	3.05	8.93
1 gang plate, duplex receptacle or toggle switch	CE@.050	Ea	8.76	3.05	11.81
1 gang plate, GFIC and rocker switch	CE@.050	Ea	8.76	3.05	11.81
2 gang plate, double duplex or toggle switches	CE@.100	Ea	7.51	6.10	13.61
2 gang plate, double GFIC and rocker switches	CE@.100	Ea	7.51	6.10	13.61
3 gang plate, duplex receptacles or switches	CE@.150	Ea	11.60	9.15	20.75
Grounding Devices No excavation or concrete included.					
Copper-clad grounding rods, driven					
1/2" x 8'	E4@.365	Ea	16.50	18.70	35.20
5/8" x 8'	E4@.365	Ea	17.90	18.70	36.60
5/8" x 10'	E4@.420	Ea	26.30	21.60	47.90
3/4" x 8'	E4@.365	Ea	39.10	18.70	57.80
3/4" x 10'	E4@.420	Ea	41.00	21.60	62.60

26 Electrical

	Craft@Hrs	Unit	Material	Labor	Total
Grounding locknuts					
1/2" locknuts	E4@.050	Ea	1.79	2.57	4.36
3/4" locknuts	E4@.060	Ea	2.28	3.08	5.36
1" locknuts	E4@.080	Ea	3.08	4.11	7.19
1-1/4" locknuts	E4@.100	Ea	4.11	5.13	9.24
1-1/2" locknuts	E4@.100	Ea	5.54	5.13	10.67
2" locknuts	E4@.150	Ea	7.54	7.70	15.24
2-1/2" locknuts	E4@.200	Ea	15.30	10.30	25.60
3" locknuts	E4@.200	Ea	19.20	10.30	29.50
4" locknuts	E4@.300	Ea	40.00	15.40	55.40
Ground rod clamps					
1/2" clamp	E4@.249	Ea	2.36	12.80	15.16
5/8" clamp	E4@.249	Ea	2.78	12.80	15.58
3/4" clamp	E4@.249	Ea	3.97	12.80	16.77
Coupling for threaded ground rod					
5/8" clamp	E4@.249	Ea	14.80	12.80	27.60
3/4" clamp	E4@.249	Ea	20.50	12.80	33.30
Copper bonding connector straps, 3/4" x .050"					
1" strap	E4@.286	Ea	14.80	14.70	29.50
2" strap	E4@.300	Ea	19.10	15.40	34.50
3" strap	E4@.315	Ea	25.50	16.20	41.70
4" strap	E4@.330	Ea	30.30	16.90	47.20
Braze connections for wire					
#6 wire	E4@.194	Ea	1.50	9.96	11.46
#2 wire	E4@.194	Ea	1.76	9.96	11.72
#1/0 wire	E4@.295	Ea	4.74	15.10	19.84
#4/0 wire	E4@.391	Ea	12.00	20.10	32.10
Grounding using a 5/8" x 8' copper clad ground rod, includes 10' grounding conductor, clamps, connectors, locknut, and rod.					
100 amp service, #8 copper wire	E4@1.13	Ea	43.00	58.00	101.00
150 amp service, #6 copper wire	E4@1.16	Ea	46.10	59.60	105.70
Electric Motors General purpose, 3 phase, open drip-proof, industrial duty, 1,700-1,780 RPM, 208-230/460 volt, rigid welded or solid base, furnished and placed, no hookup included. Based on Dayton motors.					
1/2 HP	E4@1.99	Ea	235.00	102.00	337.00
3/4 HP	E4@1.99	Ea	264.00	102.00	366.00
1 HP	E4@1.99	Ea	280.00	102.00	382.00
1-1/2 HP	E4@1.99	Ea	291.00	102.00	393.00
2 HP	E4@1.99	Ea	298.00	102.00	400.00
3 HP	E4@1.99	Ea	323.00	102.00	425.00
5 HP	E4@2.22	Ea	377.00	114.00	491.00
7-1/2 HP	E4@2.40	Ea	555.00	123.00	678.00
10 HP	E4@2.51	Ea	644.00	129.00	773.00
Electric Motor Connection Includes a NEMA-1 fusible heavy duty safety switch, connectors, fittings, ells, adapters, supports, anchors and conduit with wire appropriate for the load connected but no starter or motor.					
Single phase, using 10' RSC, 20' PVC and 6' flex conduit, NEMA Class 1 (indoor) general duty switch, 240 V					
For motor to 2 HP, 20 amps	E4@6.35	Ea	181.00	326.00	507.00
For 2.5 to 3 HP motor, 30 amps	E4@6.63	Ea	185.00	340.00	525.00
For 3 HP motor, 45 amps	E4@6.68	Ea	358.00	343.00	701.00
For 8 to 15 HP motor, 90 amps	E4@13.4	Ea	570.00	688.00	1,258.00

26 Electrical

	Craft@Hrs	Unit	Material	Labor	Total
Three phase wiring using 10' RSC, 20' PVC and 6' flex conduit, NEMA Class 1 (indoor) switch, 600 V					
For motor to 2 HP, 20 amps	E4@7.18	Ea	337.00	369.00	706.00
For 3 to 5 HP motor, 30 amps	E4@7.90	Ea	341.00	406.00	747.00
For 7 to 10 HP motor, 45 amps	E4@8.30	Ea	413.00	426.00	839.00
For 25 to 50 HP motor, 90 amps	E4@9.30	Ea	849.00	477.00	1,326.00
For 50 to 100 HP motor, 135 amps	E4@14.1	Ea	1,320.00	724.00	2,044.00
For 100 to 200 HP motor, 270 amps	E4@21.9	Ea	3,710.00	1,120.00	4,830.00
Single phase, using 10' RSC, 20' PVC and 6' flex conduit, NEMA Class 3R (weatherproof) switch, 240 V					
For motor to 2 HP, 20 amps	E4@6.63	Ea	207.00	340.00	547.00
For 2 to 5 HP motor, 30 amps	E4@6.97	Ea	211.00	358.00	569.00
For 5 to 7.5 HP motor, 45 amps	E4@6.94	Ea	294.00	356.00	650.00
Three phase using 10' RSC, 20' PVC and 6' flex conduit, NEMA Class 3R (weatherproof) switch, 600 V					
For motor to 5 HP motor, 20 amps	E4@7.10	Ea	446.00	365.00	811.00
For 1 to 10 HP motor, 30 amps	E4@7.25	Ea	450.00	372.00	822.00
For 10 to 25 HP motor, 45 amps	E4@9.51	Ea	548.00	488.00	1,036.00
For 25 to 50 HP motor, 90 amps	E4@9.51	Ea	977.00	488.00	1,465.00
For 60 to 100 HP motor, 135 amps	E4@12.1	Ea	1,470.00	621.00	2,091.00
For 125 to 200 HP motor, 270 amps	E4@21.6	Ea	4,030.00	1,110.00	5,140.00
Electric Motor Connection Complete installation, including magnetic motor starter, overload relay, all wiring, a heavy duty fusible safety switch, junction box and cover, connectors, fittings, adapters, supports, anchors and conduit appropriate for the load connected. No motor included.					
Single phase, using 10' RSC, 20' PVC and 6' flex conduit, NEMA Class 1 (indoor) starter, 230 V					
For motor to 2 HP, 20 amps	E4@8.11	Ea	389.00	416.00	805.00
For 2 to 3 HP motor, 30 amps	E4@8.32	Ea	433.00	427.00	860.00
For 3 to 8 HP motor, 45 amps	E4@8.45	Ea	625.00	434.00	1,059.00
For 8 to 15 HP motor, 90 amps	E4@15.5	Ea	1,080.00	796.00	1,876.00
Three phase wiring using 10' RSC, 20' PVC and 6' flex conduit, NEMA Class 1 (indoor) starter, 480 V					
For motor to 2 HP, 20 amps	E4@9.90	Ea	982.00	508.00	1,490.00
For 2 to 5 HP motor, 30 amps	E4@10.6	Ea	1,030.00	544.00	1,574.00
For 7 to 25 HP motor, 45 amps	E4@20.5	Ea	1,590.00	1,050.00	2,640.00
For 25 to 50 HP motor, 90 amps	E4@23.1	Ea	2,750.00	1,190.00	3,940.00
Single phase, using 10' RSC, 20' PVC and 6' flex conduit, NEMA Type 3R (weatherproof) starter, 230 V					
For motor to 2 HP, 20 amps	E4@8.91	Ea	521.00	457.00	978.00
For 2 to 5 HP motor, 30 amps	E4@9.15	Ea	588.00	470.00	1,058.00
For 5 to 7.5 HP motor, 45 amps	E4@9.25	Ea	838.00	475.00	1,313.00
Three phase using 10' RSC, 20' PVC and 6' flex conduit, NEMA Type 3R (weatherproof) starter, 480 V					
For motor to 5 HP, 20 amps	E4@10.9	Ea	1,400.00	560.00	1,960.00
For 5 to 10 HP motor, 30 amps	E4@11.7	Ea	1,470.00	601.00	2,071.00
For 10 to 25 HP motor, 45 amps	E4@22.5	Ea	2,290.00	1,160.00	3,450.00
For 25 to 50 HP motor, 90 amps	E4@25.4	Ea	3,900.00	1,300.00	5,200.00
Motor Starters Magnetic operated full voltage non-reversing motor controllers with thermal overload relays and enclosure.					
Two pole, 1 phase contactors, NEMA Class 1 (indoor), electrically held with holding interlock, one reset					
Size 00, 1/3 HP, 9 amp	E4@1.47	Ea	281.00	75.50	356.50
Size 0, 1 HP, 18 amp	E4@1.62	Ea	325.00	83.20	408.20
Size 1, 2 HP, 27 amp	E4@1.73	Ea	369.00	88.80	457.80
Size 2, 3 HP, 45 amp	E4@1.73	Ea	474.00	88.80	562.80
Size 3, 7-1/2 HP, 90 amp	E4@2.02	Ea	675.00	104.00	779.00

26 Electrical

	Craft@Hrs	Unit	Material	Labor	Total
Three pole polyphase NEMA Class 1 (indoor) AC magnetic combination starters with fusible disconnect and overload relays but no heaters, 208 to 240 volts					
Size 0, 3 HP, 30 amps	E4@2.75	Ea	890.00	141.00	1,031.00
Size 1, 7.5 HP, 30 amps	E4@3.89	Ea	936.00	200.00	1,136.00
Size 1, 10 HP, 60 amps	E4@3.89	Ea	936.00	200.00	1,136.00
Size 2, 10 HP, 60 amps	E4@5.34	Ea	1,490.00	274.00	1,764.00
Size 2, 25 HP, 100 amps	E4@5.34	Ea	1,490.00	274.00	1,764.00
Size 3, 25 HP, 100 amps	E4@6.76	Ea	2,450.00	347.00	2,797.00
Size 3, 50 HP, 200 amps	E4@6.76	Ea	2,450.00	347.00	2,797.00
Size 4, 40 HP, 200 amps	E4@12.0	Ea	4,740.00	616.00	5,356.00
Size 4, 75 HP, 400 amps	E4@12.0	Ea	4,740.00	616.00	5,356.00
On and off switches for starter enclosures, any motor starter above					
Switch kit without pilot light	E4@.744	Ea	92.90	38.20	131.10
Switch kit with pilot light	E4@.744	Ea	140.00	38.20	178.20
Accessories for any motor starter					
Add for 440 to 600 volt starters	—	%	2.0	—	—
Add for NEMA Type 3R (rainproof) enclosure	—	%	40.0	10.0	—
Add for NEMA Type 4 (waterproof) enclosure	—	%	40.0	20.0	—
Add for NEMA Type 12 (dust-tight) enclosure	—	%	15.0	15.0	—
Add for starters in an oversize enclosure	—	%	21.0	—	—
Deduct for starters with circuit breakers	—	%	-4.0	—	—
Safety Switches Wall mounted switches with enclosures as noted. No fuses or hubs included.					
Heavy-duty (NEMA-1) 600 volt 2, 3 or 4 pole fusible safety switches					
30 amp	E4@3.06	Ea	204.00	157.00	361.00
60 amp	E4@3.89	Ea	236.00	200.00	436.00
100 amp	E4@4.20	Ea	440.00	216.00	656.00
200 amp	E4@6.92	Ea	634.00	355.00	989.00
400 amp	E4@11.4	Ea	1,560.00	585.00	2,145.00
600 amp	E4@14.3	Ea	2,320.00	734.00	3,054.00
800 amp	E4@19.6	Ea	3,230.00	1,010.00	4,240.00
1,200 amp	E4@22.7	Ea	5,450.00	1,170.00	6,620.00
Heavy-duty rainproof (NEMA-3R) 600 volt 2, 3 or 4 pole fusible safety switches					
30 amp	E4@3.32	Ea	302.00	170.00	472.00
60 amp	E4@4.61	Ea	358.00	237.00	595.00
100 amp	E4@4.77	Ea	556.00	245.00	801.00
200 amp	E4@7.51	Ea	765.00	386.00	1,151.00
400 amp	E4@12.4	Ea	1,850.00	637.00	2,487.00
600 amp	E4@15.6	Ea	3,700.00	801.00	4,501.00
800 amp	E4@21.4	Ea	5,560.00	1,100.00	6,660.00
1,200 amp	E4@25.8	Ea	6,100.00	1,320.00	7,420.00
Heavy-duty watertight (NEMA-4) 600 volt 3 pole, 4 wire fusible safety switches					
30 amp	E4@3.76	Ea	663.00	193.00	856.00
60 amp	E4@5.21	Ea	1,080.00	267.00	1,347.00
100 amp	E4@5.34	Ea	1,700.00	274.00	1,974.00
200 amp	E4@8.52	Ea	2,380.00	437.00	2,817.00
400 amp	E4@13.7	Ea	4,720.00	703.00	5,423.00
600 amp	E4@17.0	Ea	6,690.00	873.00	7,563.00
Heavy-duty dust-tight (NEMA-12) 600 volt 3 pole or 4 pole solid neutral fusible safety switches					
30 amp	E4@3.32	Ea	266.00	170.00	436.00
60 amp	E4@4.20	Ea	260.00	216.00	476.00
100 amp	E4@4.48	Ea	417.00	230.00	647.00
200 amp	E4@7.51	Ea	648.00	386.00	1,034.00
400 amp	E4@12.7	Ea	1,480.00	652.00	2,132.00
600 amp	E4@15.9	Ea	2,500.00	816.00	3,316.00

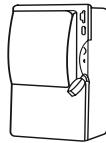

26 Electrical

	Craft@Hrs	Unit	Material	Labor	Total
General duty (NEMA-1) 240 volt 3 pole, 4 wire non-fusible safety switches					
30 amp	E4@2.58	Ea	61.40	132.00	193.40
100 amp	E4@3.60	Ea	185.00	185.00	370.00
200 amp	E4@6.50	Ea	392.00	334.00	726.00
400 amp	E4@10.8	Ea	1,020.00	554.00	1,574.00
600 amp	E4@12.7	Ea	1,910.00	652.00	2,562.00
General duty rainproof (NEMA-3R) 240 volt 3 pole, 4 wire non-fusible safety switches					
30 amp	E4@2.88	Ea	84.90	148.00	232.90
60 amp	E4@3.76	Ea	128.00	193.00	321.00
100 amp	E4@3.89	Ea	236.00	200.00	436.00
200 amp	E4@7.23	Ea	423.00	371.00	794.00
400 amp	E4@11.8	Ea	1,060.00	606.00	1,666.00
600 amp	E4@14.0	Ea	2,280.00	719.00	2,999.00
Heavy duty watertight (NEMA-4) 240 volt 3 pole, 4 wire fusible safety switches					
30 amp	E4@3.19	Ea	488.00	164.00	652.00
60 amp	E4@3.76	Ea	573.00	193.00	766.00
100 amp	E4@4.33	Ea	1,170.00	222.00	1,392.00
200 amp	E4@7.80	Ea	1,590.00	400.00	1,990.00
400 amp	E4@13.0	Ea	3,490.00	667.00	4,157.00
600 amp	E4@15.4	Ea	4,880.00	791.00	5,671.00
Heavy duty dust-tight (NEMA-12) 240 volt 3 pole, 4 wire fusible safety switches					
30 amp	E4@2.88	Ea	274.00	148.00	422.00
60 amp	E4@3.76	Ea	353.00	193.00	546.00
100 amp	E4@4.04	Ea	506.00	207.00	713.00
200 amp	E4@7.23	Ea	678.00	371.00	1,049.00
400 amp	E4@11.8	Ea	1,700.00	606.00	2,306.00
600 amp	E4@14.0	Ea	2,850.00	719.00	3,569.00
Add for conduit hubs					
3/4" to 1-1/2", to 100 amp	—	Ea	15.70	—	15.70
2", 200 amp	—	Ea	27.50	—	27.50
2-1/2", 200 amp	—	Ea	46.30	—	46.30
Service Entrance and Distribution Switchboards MA Class 1 indoor, 600 volt, 3 phase, 4 wire, for 240/480 volt insulated case main breakers. Basic structure is 90" high by 21" deep. Width varies with equipment capacity. Labor cost includes setting and leveling on a prepared pad but excludes the pad cost. Add breaker, instrumentation and accessory costs for a complete installation. Based on Westinghouse Pow-R-Gear. These switchboards are custom designed for each installation. Costs can vary widely. Multiple units ordered at the same time may reduce costs per unit by 25% or more.					
600 amp bus	E4@22.9	Ea	5,040.00	1,180.00	6,220.00
1,000 amp bus	E4@22.9	Ea	5,210.00	1,180.00	6,390.00
1,200 amp bus	E4@22.9	Ea	6,320.00	1,180.00	7,500.00
1,600 amp bus	E4@22.9	Ea	7,280.00	1,180.00	8,460.00
2,000 amp bus	E4@22.9	Ea	7,970.00	1,180.00	9,150.00
2,500 amp bus	E4@22.9	Ea	9,730.00	1,180.00	10,910.00
3,000 amp bus	E4@22.9	Ea	11,300.00	1,180.00	12,480.00
4,000 amp bus	E4@22.9	Ea	14,400.00	1,180.00	15,580.00
240/480 volt draw-out main breakers, 100K amp interrupt capacity. Includes connecting and testing breakers only.					
Based on Pow-R-Trip					
100 to 800 amp, manual operation	E4@10.2	Ea	14,600.00	524.00	15,124.00
1,000 to 1,600 amp, manual operation	E4@17.5	Ea	30,800.00	898.00	31,698.00
2,000 amp, manual operation	E4@23.2	Ea	37,500.00	1,190.00	38,690.00
2,500 amp, manual operation	E4@23.2	Ea	64,200.00	1,190.00	65,390.00
3,000 amp, manual operation	E4@23.2	Ea	71,500.00	1,190.00	72,690.00
4,000 amp, manual operation	E4@23.2	Ea	85,900.00	1,190.00	87,090.00

26 Electrical

	Craft@Hrs	Unit	Material	Labor	Total
100 to 800 amp electric operation	E4@10.2	Ea	19,700.00	524.00	20,224.00
1,000 to 1,600 amp electric operation	E4@17.5	Ea	33,800.00	898.00	34,698.00
2,000 amp electric operation	E4@23.2	Ea	44,700.00	1,190.00	45,890.00
2,500 amp electric operation	E4@23.2	Ea	76,600.00	1,190.00	77,790.00
3,000 amp electric operation	E4@23.2	Ea	83,400.00	1,190.00	84,590.00
Additional space for future draw-out breakers					
100 to 800 amp	—	Ea	3,980.00	—	3,980.00
1,000 to 1,600 amp	—	Ea	5,790.00	—	5,790.00
2,000 amp	—	Ea	6,540.00	—	6,540.00
2,500 amp	—	Ea	6,980.00	—	6,980.00
3,000 amp	—	Ea	12,700.00	—	12,700.00
Service Entrance and Distribution Switchboards, Weatherproof					
600 volt, 3 phase, 4 wire, for 480 volt insulated case main breakers. Basic structure is 90" high by 21" deep. Width varies with equipment capacity. Labor cost includes setting and leveling on a prepared pad but excludes the pad cost. Add breaker, instrumentation and accessory costs from below for a complete installation. These switchboards are custom designed for each installation. Costs can vary widely. Multiple units ordered at the same time can reduce costs per unit by 25% or more.					
600 amp bus	E4@23.2	Ea	5,950.00	1,190.00	7,140.00
1,000 amp bus	E4@23.2	Ea	6,990.00	1,190.00	8,180.00
1,200 amp bus	E4@23.2	Ea	8,980.00	1,190.00	10,170.00
1,600 amp bus	E4@23.2	Ea	8,590.00	1,190.00	9,780.00
2,000 amp bus	E4@23.2	Ea	9,510.00	1,190.00	10,700.00
2,500 amp bus	E4@23.2	Ea	11,500.00	1,190.00	12,690.00
3,000 amp bus	E4@23.2	Ea	11,700.00	1,190.00	12,890.00
4,000 amp bus	E4@23.2	Ea	17,000.00	1,190.00	18,190.00
480 volt manual operated draw-out breakers. By amp interrupt capacity (AIC) as noted. Includes connecting and testing factory installed breakers only.					
50 to 800 amp, 30K AIC	E4@10.2	Ea	19,900.00	524.00	20,424.00
50 to 1,600 amp, 50K AIC	E4@17.5	Ea	41,600.00	898.00	42,498.00
2,000 amp	E4@23.2	Ea	53,700.00	1,190.00	54,890.00
1,200 to 3,200 amp	E4@23.2	Ea	94,700.00	1,190.00	95,890.00
4,000 amp	E4@23.2	Ea	150,000.00	1,190.00	151,190.00
480 volt manual operated draw-out breakers. 200K amp interrupt capacity (AIC) as noted. Includes connecting and testing factory installed breakers only.					
50 to 800 amp	E4@10.2	Ea	30,900.00	524.00	31,424.00
50 to 1,600 amp	E4@17.5	Ea	55,000.00	898.00	55,898.00
1,200 to 3,200 amp	E4@23.2	Ea	141,000.00	1,190.00	142,190.00
4,000 amp	E4@23.2	Ea	228,000.00	1,190.00	229,190.00
480 volt electrically operated draw-out breakers. By amp interrupt capacity (AIC) as noted. Includes connecting and testing factory installed breakers only.					
50 to 800 amp, 30K AIC	E4@10.2	Ea	27,400.00	524.00	27,924.00
50 to 1,600 amp, 50K AIC	E4@17.5	Ea	56,800.00	898.00	57,698.00
2,000 amp	E4@23.2	Ea	72,200.00	1,190.00	73,390.00
1,200 to 3,200 amp	E4@23.2	Ea	109,000.00	1,190.00	110,190.00
4,000 amp	E4@23.2	Ea	168,000.00	1,190.00	169,190.00
480 volt electrically operated draw-out breakers. 200K amp interrupt capacity (AIC) as noted. Includes connecting and testing factory installed breakers only.					
50 to 800 amp	E4@10.2	Ea	37,700.00	524.00	38,224.00
50 to 1,600 amp	E4@17.5	Ea	76,100.00	898.00	76,998.00
1,200 to 3,200 amp	E4@23.2	Ea	155,000.00	1,190.00	156,190.00
4,000 amp	E4@23.2	Ea	229,000.00	1,190.00	230,190.00

26 Electrical

	Craft@Hrs	Unit	Material	Labor	Total
Additional space for future draw-out breakers					
50 to 800 amp	—	Ea	4,660.00	—	4,660.00
50 to 1,600 amp	—	Ea	7,570.00	—	7,570.00
2,000 amp	—	Ea	10,300.00	—	10,300.00
1,200 to 3,200 amp	—	Ea	16,000.00	—	16,000.00
4,000 amp	—	Ea	29,700.00	—	29,700.00
Switchboard Instrumentation and Accessories Add these costs to the cost of the basic enclosure and breakers to find the complete switchboard cost. These figures are for factory-installed instrumentation and accessories and include the cost of connecting and testing only.					
Bus duct connection, 3 phase, 4 wire					
225 amp	CE@.516	Ea	902.00	31.50	933.50
400 amp	CE@.516	Ea	1,040.00	31.50	1,071.50
600 amp	CE@.516	Ea	1,270.00	31.50	1,301.50
800 amp	CE@.516	Ea	2,000.00	31.50	2,031.50
1,000 amp	CE@.516	Ea	2,320.00	31.50	2,351.50
1,350 amp	CE@1.01	Ea	3,020.00	61.60	3,081.60
1,600 amp	CE@1.01	Ea	3,490.00	61.60	3,551.60
2,000 amp	CE@1.01	Ea	4,270.00	61.60	4,331.60
2,500 amp	CE@1.01	Ea	5,070.00	61.60	5,131.60
3,000 amp	CE@1.01	Ea	5,780.00	61.60	5,841.60
4,000 amp	CE@1.01	Ea	6,400.00	61.60	6,461.60
Recording meters					
Voltmeter	CE@1.01	Ea	12,900.00	61.60	12,961.60
Ammeter	CE@1.01	Ea	13,200.00	61.60	13,261.60
Wattmeter	CE@1.01	Ea	16,100.00	61.60	16,161.60
Varmeter	CE@1.01	Ea	17,100.00	61.60	17,161.60
Power factor meter	CE@1.01	Ea	16,900.00	61.60	16,961.60
Frequency meter	CE@1.01	Ea	16,900.00	61.60	16,961.60
Watt-hour meter, 3 element	CE@1.01	Ea	21,900.00	61.60	21,961.60
Non-recording meters					
Voltmeter	CE@.516	Ea	2,130.00	31.50	2,161.50
Ammeter for incoming line	CE@.516	Ea	2,190.00	31.50	2,221.50
Ammeter for feeder circuits	CE@.516	Ea	912.00	31.50	943.50
Wattmeter	CE@1.01	Ea	7,090.00	61.60	7,151.60
Varmeter	CE@1.01	Ea	6,410.00	61.60	6,471.60
Power factor meter	CE@1.01	Ea	5,160.00	61.60	5,221.60
Frequency meter	CE@1.01	Ea	6,130.00	61.60	6,191.60
Watt-hour meter, 3 element	CE@1.01	Ea	6,410.00	61.60	6,471.60
Instrument phase select switch	CE@.516	Ea	1,110.00	31.50	1,141.50
Adjustable short time pickup and delay	CE@.516	Ea	1,660.00	31.50	1,691.50
Ground fault trip pickup and delay, 4 wire	CE@.525	Ea	1,780.00	32.00	1,812.00
Ground fault test panel	CE@.516	Ea	1,910.00	31.50	1,941.50
Shunt trip for breakers	CE@.516	Ea	1,300.00	31.50	1,331.50
Key interlock for breakers	CE@.516	Ea	1,300.00	31.50	1,331.50
Breaker lifting and transport truck	—	Ea	8,420.00	—	8,420.00
Breaker lifting device	—	Ea	7,340.00	—	7,340.00
Current transformers, by primary capacity					
800 amps and less	CE@1.01	Ea	1,600.00	61.60	1,661.60
1,000 to 1,500 amps	CE@1.01	Ea	2,370.00	61.60	2,431.60
2,000 to 6,000 amps	CE@1.01	Ea	2,800.00	61.60	2,861.60
Current transformer mount	—	Ea	758.00	—	758.00
Potential transformer	CE@1.01	Ea	2,070.00	61.60	2,131.60
Potential transformer mount	—	Ea	478.00	—	478.00

26 Electrical

	Craft@Hrs	Unit	Material	Labor	Total
Feeder Section Breaker Panels					
Flush or surface mounted 277/480 volt, 3 phase, 4 wire, FA frame panels.					
225 amp, with 22K amp interrupt capacity breaker	E4@6.76	Ea	2,130.00	347.00	2,477.00
225 amp, with 25K amp interrupt capacity breaker	E4@6.76	Ea	3,980.00	347.00	4,327.00
400 amp, with 30K amp interrupt capacity breaker	E4@10.8	Ea	4,770.00	554.00	5,324.00
400 amp, with 35K amp interrupt capacity breaker	E4@10.8	Ea	5,710.00	554.00	6,264.00
225 amp, with main lugs only	E4@6.76	Ea	720.00	347.00	1,067.00
400 amp, with main lugs only	E4@10.8	Ea	1,010.00	554.00	1,564.00
600 amp, with main lugs only	E4@19.3	Ea	1,370.00	991.00	2,361.00
Transformers Indoor dry-type transformer, floor mounted, including connections.					
Single phase light and power circuit transformer, 240/480 volt primary, 120/240 secondary, no taps for voltage change					
1 KVA	E4@3.76	Ea	351.00	193.00	544.00
2 KVA	E4@4.20	Ea	526.00	216.00	742.00
3 KVA	E4@4.33	Ea	667.00	222.00	889.00
5 KVA	E4@5.47	Ea	867.00	281.00	1,148.00
7.5 KVA	E4@8.34	Ea	1,080.00	428.00	1,508.00
10 KVA	E4@9.38	Ea	1,330.00	482.00	1,812.00
15 KVA	E4@12.6	Ea	1,540.00	647.00	2,187.00
25 KVA	E4@12.6	Ea	2,110.00	647.00	2,757.00
Three phase light and power circuit transformers, 480 volt primary, 120/208 volt secondary, with 6 taps for voltage change					
30 KVA	E4@10.5	Ea	3,940.00	539.00	4,479.00
45 KVA	E4@12.6	Ea	4,710.00	647.00	5,357.00
50 KVA	E4@12.6	Ea	6,260.00	647.00	6,907.00
75 KVA	E4@14.8	Ea	7,100.00	760.00	7,860.00
112.5 KVA	E4@15.7	Ea	9,430.00	806.00	10,236.00
150 KVA	E4@16.7	Ea	12,200.00	857.00	13,057.00
225 KVA	E4@18.9	Ea	16,600.00	970.00	17,570.00
300 KVA	E4@21.2	Ea	21,400.00	1,090.00	22,490.00
Three phase 5,000 volt load center transformers, 4,160 volt primary, 480/277 volt secondary, with voltage change taps, insulation class H, 80 degree system					
225 KVA	E4@29.5	Ea	20,500.00	1,510.00	22,010.00
300 KVA	E4@33.7	Ea	24,100.00	1,730.00	25,830.00
500 KVA	E4@42.5	Ea	36,400.00	2,180.00	38,580.00
750 KVA	E4@53.1	Ea	47,600.00	2,730.00	50,330.00
1,000 KVA	E4@63.2	Ea	62,300.00	3,240.00	65,540.00
Panelboards Surface mounted lighting and appliance distribution panelboards for bolt-on circuit breakers. No breakers included.					
3 wire 120/240 volt, 250 amp, single phase AC panelboards with main lugs only for bolt-on breakers					
18 circuits	E4@10.7	Ea	333.00	549.00	882.00
30 circuits	E4@15.3	Ea	339.00	786.00	1,125.00
42 circuits	E4@20.9	Ea	446.00	1,070.00	1,516.00
Deduct for 3 wire 120/240 panelboards With main lugs only	—	%	-10.0	-15.0	—
4 wire 120/208 volt, 250 amp, 3 phase AC panelboards for bolt-on breakers, with main circuit breaker only					
18 circuits	E4@12.9	Ea	271.00	662.00	933.00
30 circuits	E4@21.5	Ea	384.00	1,100.00	1,484.00
42 circuits	E4@30.1	Ea	498.00	1,550.00	2,048.00
Deduct for 3 wire panelboards With circuit breaker mains only	—	%	-10.0	-15.0	—

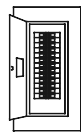

26 Electrical

	Craft@Hrs	Unit	Material	Labor	Total
Combination Service Entrance Device Meter socket, service disconnect and loadcenter.					
Surface mount NEMA Type 3R enclosure with ring type utility meter socket, service disconnect, and integral HOM loadcenter. Single phase 3-wire. 120/240 Volt AC, 22,000 amp short circuit current rating. Overhead or underground service feed. Add the cost of distribution breakers and conduit hubs.					
100 amp, 16 spaces, 24 circuits	E4@1.20	Ea	91.10	61.60	152.70
125 amp, 16 spaces, 24 circuits	E4@1.20	Ea	125.00	61.60	186.60
200 amp, 20 spaces, 40 circuits	E4@1.20	Ea	169.00	61.60	230.60
200 amp, 20 spaces, 40 circuits	E4@2.60	Ea	150.00	133.00	283.00
200 amp, 30 spaces, 40 circuits	E4@2.60	Ea	345.00	133.00	478.00
200 amp, 40 spaces, 40 circuits	E4@2.60	Ea	139.00	133.00	272.00
320 amp, 30 spaces, 40 circuits, no bypass	E4@3.10	Ea	879.00	159.00	1,038.00
320 amp, 30 spaces, 40 circuits, test block bypass	E4@3.10	Ea	764.00	159.00	923.00
Surface mount NEMA Type 3R class 4120 enclosure with ring type utility meter socket, dual main breakers and HO load center. Single phase, 3-wire, 120/240 Volts AC, 25,000 amp short circuit current rating. Underground service feed. With 100 percent branch neutrals, horn by-pass and 5th jaw factory installed. Add the cost of distribution breakers and conduit hubs.					
400 amp, 30 spaces, 40 circuits, test block bypass	E4@3.50	Ea	909.00	180.00	1,089.00
400 amp, 30 spaces, 40 circuits, no test block	E4@3.50	Ea	909.00	180.00	1,089.00
Surface or semi-flush mount NEMA Type 1 (indoor) enclosure with multiple meter positions, main breaker and loadcenter. Line and load at top or bottom. 1 phase, 3-wire 120/240 Volt AC. 65,000 amp short circuit rating. Add the cost of distribution breakers and conduit hubs.					
125 amp, 200 amp bus, 2 meter positions	E4@1.20	Ea	264.00	61.60	325.60
125 amp, 300 amp bus, 3 meter positions	E4@1.20	Ea	291.00	61.60	352.60
125 amp, 400 amp bus, 4 meter position	E4@1.20	Ea	308.00	61.60	369.60
125 amp, 400 amp bus, 6 meter positions	E4@1.20	Ea	938.00	61.60	999.60
Loadcenters For plug-in branch breakers. Surface or recess mount. Add the cost of distribution breakers and conduit hubs.					
Indoor (NEMA 1) single phase 3-wire 120/240 volt loadcenter. Class 1170. 22,000 RMS amps short circuit rating. With factory installed main breaker only.					
100 amps, 8 spaces, 16 circuits	E4@1.20	Ea	61.50	61.60	123.10
100 amps, 12 spaces, 12 circuits	E4@1.20	Ea	83.70	61.60	145.30
100 amps, 20 spaces, 20 circuits	E4@1.20	Ea	61.10	61.60	122.70
100 amps, 24 spaces, 24 circuits	E4@1.20	Ea	111.00	61.60	172.60
100 amps, 30 spaces, 30 circuits	E4@1.20	Ea	116.00	61.60	177.60
125 amps, 12 spaces, 24 circuits	E4@1.52	Ea	40.00	78.00	118.00
125 amps, 24 spaces, 24 circuits	E4@1.52	Ea	131.00	78.00	209.00
150 amps, 30 spaces, 30 circuits	E4@2.30	Ea	187.00	118.00	305.00
200 amps, 20 spaces, 40 circuits	E4@2.60	Ea	92.70	133.00	225.70
200 amps, 30 spaces, 30 circuits	E4@2.60	Ea	126.00	133.00	259.00
200 amps, 40 spaces, 40 circuits	E4@2.60	Ea	142.00	133.00	275.00
Outdoor (NEMA 4) single phase 3-wire 120/240 volt loadcenter, Class 1170, 22,000 amps short circuit rating. With factory installed main breaker only.					
100 amps, 8 spaces, 16 circuits	E4@1.20	Ea	69.80	61.60	131.40
100 amps, 12 spaces, 12 circuits	E4@1.20	Ea	116.00	61.60	177.60
100 amps, 20 spaces, 20 circuits	E4@1.20	Ea	147.00	61.60	208.60
125 amps, 24 spaces, 24 circuits	E4@1.52	Ea	126.00	78.00	204.00
150 amps, 30 spaces, 30 circuits	E4@2.30	Ea	284.00	118.00	402.00
200 amps, 20 spaces, 40 circuits	E4@2.60	Ea	192.00	133.00	325.00
200 amps, 30 spaces, 30 circuits	E4@2.60	Ea	264.00	133.00	397.00
200 amps, 40 spaces, 40 circuits	E4@2.60	Ea	214.00	133.00	347.00

26 Electrical

	Craft@Hrs	Unit	Material	Labor	Total
Indoor (NEMA 1) three phase 4 wire 120/208 volt loadcenter with factory-installed main circuit breaker only.					
100 amps, 12 circuits	E4@1.21	Ea	166.00	62.10	228.10
100 amps, 18 circuits	E4@1.60	Ea	223.00	82.10	305.10
125 amps, 30 circuits	E4@1.91	Ea	445.00	98.10	543.10
150 amps, 24 circuits	E4@2.18	Ea	428.00	112.00	540.00
150 amps, 42 circuits	E4@2.82	Ea	511.00	145.00	656.00
200 amps, 42 circuits	E4@3.63	Ea	511.00	186.00	697.00
225 amps, 42 circuits	E4@3.78	Ea	534.00	194.00	728.00
400 amps, 24 circuits	E4@3.91	Ea	1,080.00	201.00	1,281.00
400 amps, 42 circuits	E4@4.51	Ea	1,240.00	232.00	1,472.00
Three phase 4 wire 120/208 volt loadcenters with main lugs only.					
125 amps, 12 circuits	E4@1.19	Ea	98.40	61.10	159.50
150 amps, 18 circuits	E4@1.47	Ea	148.00	75.50	223.50
200 amps, 30 circuits	E4@1.90	Ea	199.00	97.50	296.50
200 amps, 40 circuits	E4@2.18	Ea	267.00	112.00	379.00
225 amps, 42 circuits	E4@2.75	Ea	280.00	141.00	421.00
400 amps, 24 circuits	E4@3.63	Ea	513.00	186.00	699.00
400 amps, 42 circuits	E4@3.78	Ea	570.00	194.00	764.00
600 amps, 24 circuits	E4@3.91	Ea	624.00	201.00	825.00
600 amps, 42 circuits	E4@6.53	Ea	764.00	335.00	1,099.00
Circuit Breakers No enclosures included. 10,000 amp interrupt capacity except as noted.					
Plug-in molded case 120/240 volt, 100 amp frame circuit breakers, 1" or 1/2" module					
15 to 50 amps, single pole	CE@.270	Ea	9.32	16.50	25.82
15 to 60 amps, two pole	CE@.374	Ea	12.50	22.80	35.30
70 amps, two pole	CE@.563	Ea	39.30	34.30	73.60
80 to 100 amps, two pole	CE@.680	Ea	50.40	41.50	91.90
Plug-in molded case 120/240 volt, 100 amp frame circuit breakers, GFCI					
GFCI, 15 amp, single pole	CE@.300	Ea	43.90	18.30	62.20
GFCI, 15 amp, two pole	CE@.400	Ea	95.10	24.40	119.50
GFCI, 20 amp, single pole	CE@.300	Ea	53.80	18.30	72.10
GFCI, 20 amp, two pole	CE@.400	Ea	115.00	24.40	139.40
Plug-in molded case 120/240 volt, 100 amp frame circuit breakers, AFCI					
AFCI, 15 amp, single pole	CE@.300	Ea	38.50	18.30	56.80
AFCI, 15 amp, two pole	CE@.400	Ea	88.00	24.40	112.40
AFCI, 20 amp, single pole	CE@.300	Ea	41.30	18.30	59.60
AFCI, 20 amp, two pole	CE@.400	Ea	93.10	24.40	117.50
Plug-in molded case 120/240 volt, 100 amp frame circuit breakers, combination AFCI/GFCI					
Combination GF/AF, 15 amp, single pole	CE@.300	Ea	54.50	18.30	72.80
Combination GF/AF, 15 amp, two pole	CE@.400	Ea	91.70	24.40	116.10
Combination GF/AF, 20 amp, single pole	CE@.300	Ea	55.00	18.30	73.30
Combination GF/AF, 20 amp, two pole	CE@.400	Ea	99.80	24.40	124.20
Plug-in molded case 240 volt, 100 amp frame circuit breakers					
15 thru 60 amps, three pole	CE@.863	Ea	33.00	52.70	85.70
60 thru 100 amps, two pole	CE@.577	Ea	39.30	35.20	74.50
60 thru 100 amps, three pole	CE@.897	Ea	61.00	54.70	115.70
Plug-in molded case 480 volt, 100 amp frame circuit breakers					
70 thru 100 amps, two pole	CE@1.22	Ea	368.00	74.40	442.40
70 thru 100 amps, three pole	CE@1.71	Ea	461.00	104.00	565.00
Plug-in molded case 600 volt, 100 amp frame circuit breakers					
15 thru 60 amps, two pole	CE@.577	Ea	308.00	35.20	343.20
15 thru 60 amps, three pole	CE@.897	Ea	396.00	54.70	450.70
70 thru 100 amps, two pole	CE@1.22	Ea	413.00	74.40	487.40
70 thru 100 amps, three pole	CE@1.71	Ea	519.00	104.00	623.00
Plug-in molded case 250/600 volt, 225 amp frame circuit breakers					
125 thru 225 amps, two pole	CE@2.06	Ea	962.00	126.00	1,088.00
125 thru 225 amps, three pole	CE@2.57	Ea	1,220.00	157.00	1,377.00

26 Electrical

	Craft@Hrs	Unit	Material	Labor	Total
Plug-in molded case 250/600 volt, 400 amp frame circuit breakers					
250 thru 400 amps, two pole	CE@2.88	Ea	1,630.00	176.00	1,806.00
250 thru 400 amps, three pole	CE@4.33	Ea	1,910.00	264.00	2,174.00
Plug-in molded case 250/600 volt, 800 amp frame circuit breakers					
400 thru 600 amps, three pole	CE@6.04	Ea	2,420.00	369.00	2,789.00
700 thru 800 amps, two pole	CE@4.73	Ea	3,370.00	289.00	3,659.00
700 thru 800 amps, three pole	CE@6.71	Ea	4,340.00	409.00	4,749.00
Plug-in molded case 600 volt, 1,200 amp frame circuit breakers					
600 thru 1,200 amps, two pole	CE@9.60	Ea	5,560.00	586.00	6,146.00
600 thru 1,200 amps, three pole	CE@11.9	Ea	7,110.00	726.00	7,836.00
Space only for factory assembled panels					
Single pole space	—	Ea	25.00	—	25.00
Two pole space	—	Ea	23.10	—	23.10
Three pole space	—	Ea	30.90	—	30.90
Bolt-on molded case 120/240 volt circuit breakers					
15 thru 60 amps, one pole	CE@.320	Ea	20.90	19.50	40.40
15 thru 60 amps, two pole	CE@.484	Ea	30.30	29.50	59.80
15 thru 60 amps, three pole	CE@.638	Ea	94.30	38.90	133.20
70 thru 100 amps, two pole	CE@.712	Ea	73.10	43.40	116.50
70 thru 100 amps, three pole	CE@.946	Ea	160.00	57.70	217.70
Bolt-on molded case 480 volt circuit breakers, 65,000 amp interrupt capacity					
15 thru 60 amps, two pole	CE@.484	Ea	152.00	29.50	181.50
15 thru 60 amps, three pole	CE@.712	Ea	271.00	43.40	314.40
70 thru 100 amps, three pole	CE@.804	Ea	512.00	49.10	561.10
Circuit Breaker Panels 4 wire 3 phase 240 volts, flush-mounted, with main breaker, assembled					
100 amp service, 12 circuits	E4@4.60	Ea	605.00	236.00	841.00
100 amp service, 18 circuits	E4@6.90	Ea	643.00	354.00	997.00
100 amp service, 24 circuits	E4@8.10	Ea	696.00	416.00	1,112.00
100 amp service, 30 circuits	E4@8.20	Ea	747.00	421.00	1,168.00
100 amp service, 36 circuits	E4@8.30	Ea	797.00	426.00	1,223.00
100 amp service, 42 circuits	E4@8.40	Ea	851.00	431.00	1,282.00
225 amp service, 12 circuits	E4@8.50	Ea	1,330.00	436.00	1,766.00
225 amp service, 18 circuits	E4@8.60	Ea	1,350.00	442.00	1,792.00
225 amp service, 24 circuits	E4@8.70	Ea	1,400.00	447.00	1,847.00
225 amp service, 30 circuits	E4@10.0	Ea	1,450.00	513.00	1,963.00
225 amp service, 36 circuits	E4@12.8	Ea	1,500.00	657.00	2,157.00
225 amp service, 42 circuits	E4@15.1	Ea	1,540.00	775.00	2,315.00
Fuses No enclosures included.					
250 volt cartridge fuses, one time non-renewable					
To 30 amps	CE@.077	Ea	1.32	4.70	6.02
35 to 60 amps	CE@.077	Ea	3.04	4.70	7.74
70 to 100 amps	CE@.077	Ea	9.14	4.70	13.84
110 to 200 amps	CE@.077	Ea	16.20	4.70	20.90
225 to 400 amps	CE@.077	Ea	34.30	4.70	39.00
450 to 600 amps	CE@.077	Ea	77.90	4.70	82.60
600 volt cartridge fuses, one time non-renewable					
To 30 amps	CE@.077	Ea	12.50	4.70	17.20
35 to 60 amps	CE@.077	Ea	21.50	4.70	26.20
70 to 100 amps	CE@.077	Ea	57.10	4.70	61.80
110 to 200 amps	CE@.077	Ea	84.80	4.70	89.50
225 to 400 amps	CE@.087	Ea	170.00	5.31	175.31
450 to 600 amps	CE@.124	Ea	367.00	7.57	374.57

26 Electrical

	Craft@Hrs	Unit	Material	Labor	Total
250 volt Class H renewable fuses					
To 10 amps	CE@.077	Ea	13.70	4.70	18.40
12 to 30 amps	CE@.077	Ea	14.50	4.70	19.20
35 to 60 amps	CE@.077	Ea	15.40	4.70	20.10
70 to 100 amps	CE@.077	Ea	54.00	4.70	58.70
110 to 200 amps	CE@.077	Ea	124.00	4.70	128.70
225 to 400 amps	CE@.080	Ea	254.00	4.88	258.88
450 to 600 amps	CE@.122	Ea	366.00	7.44	373.44
600 volt Class H renewable fuses					
To 10 amps	CE@.077	Ea	36.20	4.70	40.90
12 to 30 amps	CE@.077	Ea	29.10	4.70	33.80
35 to 60 amps	CE@.077	Ea	39.10	4.70	43.80
70 to 100 amps	CE@.077	Ea	107.00	4.70	111.70
110 to 200 amps	CE@.077	Ea	213.00	4.70	217.70
225 to 400 amps	CE@.153	Ea	490.00	9.33	499.33
450 to 600 amps	CE@.223	Ea	588.00	13.60	601.60
250 volt Class RK5 non-renewable cartridge fuses					
10 to 30 amps	CE@.077	Ea	2.84	4.70	7.54
35 to 60 amps	CE@.077	Ea	7.14	4.70	11.84
70 to 100 amps	CE@.077	Ea	9.96	4.70	14.66
110 to 200 amps	CE@.077	Ea	18.00	4.70	22.70
225 to 400 amps	CE@.230	Ea	71.80	14.00	85.80
450 to 600 amps	CE@.297	Ea	101.00	18.10	119.10
650 to 1,200 amps	CE@.372	Ea	125.00	22.70	147.70
1,400 to 1,600 amps	CE@.804	Ea	168.00	49.10	217.10
1,800 to 2,000 amps	CE@1.00	Ea	216.00	61.00	277.00
600 volt Class RK5 non-renewable cartridge fuses					
10 to 30 amps	CE@.077	Ea	7.42	4.70	12.12
35 to 60 amps	CE@.077	Ea	12.90	4.70	17.60
70 to 100 amps	CE@.077	Ea	26.20	4.70	30.90
110 to 200 amps	CE@.129	Ea	52.30	7.87	60.17
225 to 400 amps	CE@.257	Ea	104.00	15.70	119.70
450 to 600 amps	CE@.354	Ea	149.00	21.60	170.60
650 to 1,200 amps	CE@.372	Ea	239.00	22.70	261.70
600 volt Class L fuses, bolt-on					
600 to 1,200 amps	CE@.333	Ea	366.00	20.30	386.30
1,500 to 1,600 amps	CE@.615	Ea	410.00	37.50	447.50
1,400 to 2,000 amps	CE@.809	Ea	455.00	49.40	504.40
2,500 amps	CE@1.10	Ea	730.00	67.10	797.10
3,000 amps	CE@1.25	Ea	742.00	76.30	818.30
3,500 to 4,000 amps	CE@1.74	Ea	1,230.00	106.00	1,336.00
5,000 amps	CE@2.33	Ea	1,590.00	142.00	1,732.00

26 Electrical

	Craft@Hrs	Unit	Material	Labor	Equipment	Total
Overhead Electrical Distribution						
Poles, pressure-treated wood, Class 4, Type C, set with crane or boom, including augured holes. Equipment is a flatbed truck with a boom and an auger						
25' high	E1@7.62	Ea	376.00	401.00	123.00	900.00
30' high	E1@7.62	Ea	484.00	401.00	123.00	1,008.00
35' high	E1@9.72	Ea	629.00	512.00	157.00	1,298.00
40' high	E1@11.5	Ea	746.00	605.00	186.00	1,537.00
Cross arms, wood, with typical hardware						
4' long	E1@2.86	Ea	94.10	151.00	46.30	291.40
5' long	E1@2.86	Ea	119.00	151.00	46.30	316.30
6' long	E1@4.19	Ea	169.00	221.00	67.80	457.80
8' long	E1@4.91	Ea	225.00	258.00	79.50	562.50
Transformers, pole-mounted, single phase 7620/13200 Y primary, 120/240 secondary, with two 2-1/2% taps above and below						
10 KVA	E1@4.14	Ea	1,530.00	218.00	67.00	1,815.00
15 KVA	E1@4.14	Ea	1,780.00	218.00	67.00	2,065.00
25 KVA	E1@4.14	Ea	2,180.00	218.00	67.00	2,465.00
36.5 KVA	E1@4.14	Ea	2,920.00	218.00	67.00	3,205.00
50 KVA	E1@4.14	Ea	3,320.00	218.00	67.00	3,605.00
75 KVA	E1@6.16	Ea	4,920.00	324.00	99.70	5,343.70
100 KVA	E1@6.16	Ea	5,620.00	324.00	99.70	6,043.70
167 KVA	E1@6.16	Ea	8,610.00	324.00	99.70	9,033.70
250 KVA	E1@6.16	Ea	8,820.00	324.00	99.70	9,243.70
333 KVA	E1@6.16	Ea	9,540.00	324.00	99.70	9,963.70
500 KVA	E1@6.16	Ea	13,300.00	324.00	99.70	13,723.70
Fused cutouts, pole mounted, 5 KV						
50 amp	E1@2.56	Ea	160.00	135.00	41.40	336.40
100 amp	E1@2.56	Ea	164.00	135.00	41.40	340.40
250 amp	E1@2.56	Ea	181.00	135.00	41.40	357.40
Switches, disconnect, pole mounted, pole arm throw, 5 KV, set of 3 with throw and lock						
400 amp	E1@45.8	Ea	2,880.00	2,410.00	741.00	6,031.00
600 amp	E1@45.8	Ea	5,420.00	2,410.00	741.00	8,571.00
1,200 amp	E1@51.4	Ea	10,500.00	2,710.00	832.00	14,042.00

26 Electrical

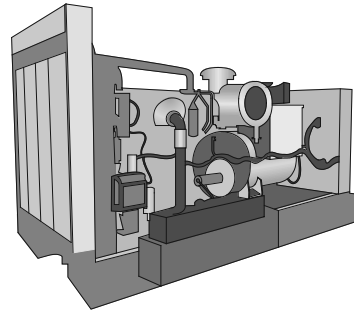
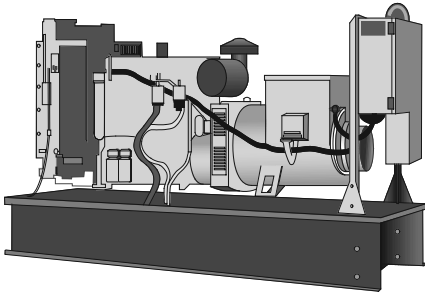

Motor generator sets Dual fuel (oil or gas) four-stroke, turbocharged eight-cylinder, 60 Hz, 480 volts, 3 phase, 1,800 RPM, UL 2200 listed, emissions certified to EPA Tier 2 rating, with *National Electrical Code*-compliant 3- or 4-pole generator and UL 1446 insulation. Control package includes digital engine and generator monitoring, metering, ground fault interruption and lightning shielding, R448 voltage regulator, RFI filter. Includes paralleling and synchronizing automatic transfer switch or (for standby emergencies) automatic dual lockout automatic transfer switch, fused main circuit breaker, electronic load-sharing module for generator ganging, electric starter motor, battery, and trickle charger, lube oil cooling system with radiator and fan, oil pump and sump, water cooling system with water pump, radiator and fan, mounting skid, sound- and weather-proof enclosure, stainless steel exhaust silencer and stack, natural gas fuel train with diaphragm regulator valve, modulating metering valve, pressure gauge and flowmeter, diesel fuel train with fuel pump, fuel pre-heater, day tank with level gauge, main dual-fuel engine inlet regulating valve, remote annunciation panel with alarms and warning lights, and NFPA-rated CO₂ fire extinguishing system. Add the cost of connecting electrical loads and electrical controls, a concrete pad for mounting on the ground or structural steel supports for mounting on a roof, approval of prints by an inspection bureau and post-construction inspection by insurance and fire inspectors. These figures assume exhaust heat is released into the atmosphere. Suitable for standby or primary power generation in commercial, light industrial, government and institutional buildings, schools and hospitals. Equipment cost assumes use of a 2-ton capacity crane.

	Craft@Hrs	Unit	Material	Labor	Equipment	Total
13 KW net electrical output	D6@24.0	Ea	7,340.00	1,330.00	1,210.00	9,880.00
17 KW net electrical output	D6@24.0	Ea	9,740.00	1,330.00	1,210.00	12,280.00
30 KW net electrical output	D6@24.0	Ea	17,000.00	1,330.00	1,210.00	19,540.00
50 KW net electrical output	D6@32.0	Ea	28,400.00	1,780.00	1,220.00	31,400.00
80 KW net electrical output	D6@32.0	Ea	45,300.00	1,780.00	1,220.00	48,300.00
100 KW net electrical output	D6@32.0	Ea	56,500.00	1,780.00	1,220.00	59,500.00
150 KW net electrical output	D6@40.0	Ea	85,100.00	2,220.00	1,790.00	89,110.00
200 KW net electrical output	D6@40.0	Ea	113,000.00	2,220.00	1,790.00	117,010.00
300 KW net electrical output	D6@40.0	Ea	170,000.00	2,220.00	1,790.00	174,010.00
400 KW net electrical output	D6@80.0	Ea	227,000.00	4,440.00	1,990.00	233,430.00
545 KW net electrical output	D6@80.0	Ea	308,000.00	4,440.00	1,990.00	314,430.00

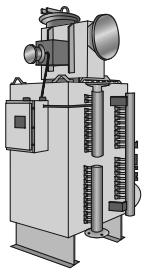

Add-on boiler modules for motor generators. Add these costs to the appropriate costs above when exhaust heat from the motor generator will be captured to power an ebullient hot water or steam boiler which is part of the building HVAC system. Based on 60 PSI hot water or 15 PSI steam. Includes boiler, temperature, pressure and level gauges, boiler feed pump, condensate return or circulating pump loop, main valve, pressure regulating valve with vent, drain line and enclosure extension. In pounds for per hour (PPH) rating, hot water or steam.

3,500 PPH (200 KW generator)	D5@40.0	Ea	35,700.00	2,080.00	—	37,780.00
5,000 PPH (300 KW generator)	D5@40.0	Ea	53,500.00	2,080.00	—	55,580.00
6,750 PPH (400 KW generator)	D5@40.0	Ea	71,500.00	2,080.00	—	73,580.00
8,000 PPH (545 KW generator)	D5@40.0	Ea	96,700.00	2,080.00	—	98,780.00

26 Electrical

Pollution control modules for motor generator sets NOx, SOx and VM (volatile materials) emissions reduction wet free-standing module for motor driven prime power and standby dual-fuel (natural gas or oil) electrical generator sets. Conforms to 2010 California Code, EPA Tier IV and European ISO standards. Verantis, Croll-Reynolds or equal. Either vertical counter-flow or packed bed wet type. For commercial and light industrial applications, schools, hospitals and governmental/institutional applications. Oil-fired turbine generators will add about 15% to the total cost, including a second stage, a second stage pump, venturi particulate separator and sludge tank. Add the cost of a permit. To calculate the annual lease rate for a complete installation, divide the total installed cost by five. Then add 2% per year to cover vendor-supplied maintenance.

	Craft@Hrs	Unit	Material	Labor	Equipment	Total
13 KW electrical output, net	U1@69.0	Ea	7,440.00	3,540.00	201.00	11,181.00
17 KW electrical output, net	U1@69.0	Ea	10,100.00	3,540.00	201.00	13,841.00
30 KW electrical output, net	U1@69.0	Ea	16,100.00	3,540.00	201.00	19,841.00
50 KW electrical output, net	U1@69.0	Ea	26,300.00	3,540.00	201.00	30,041.00
80 KW electrical output, net	U1@69.0	Ea	41,700.00	3,540.00	201.00	45,441.00
100 KW electrical output, net	U1@69.0	Ea	52,000.00	3,540.00	201.00	55,741.00
150 KW electrical output, net	U1@69.0	Ea	77,600.00	3,540.00	201.00	81,341.00
200 KW electrical output, net	U1@69.0	Ea	49,000.00	3,540.00	201.00	52,741.00
300 KW electrical output, net	U1@69.0	Ea	51,400.00	3,540.00	201.00	55,141.00
400 KW electrical output, net	U1@69.0	Ea	61,000.00	3,540.00	201.00	64,741.00
545 KW electrical output, net	U1@69.0	Ea	91,200.00	3,540.00	201.00	94,941.00

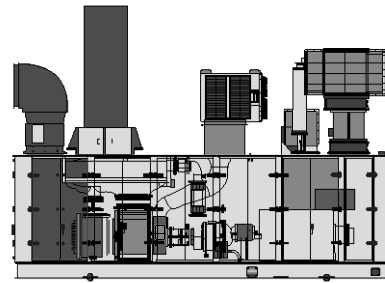
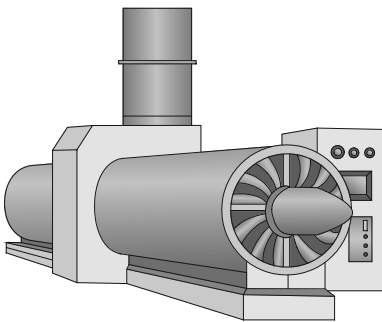

FRONT VIEW

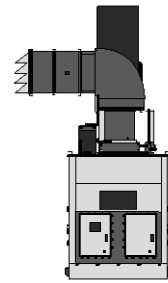

SIDE VIEW

Gas turbine generator sets Dual fuel (oil or gas) single shaft turbine with 11 stage compression, 2 stage hot section and single stage power turbine, 60 Hz, 480 volts, 3 phase, 1,800 RPM, UL 2200 listed, emissions compliance certified to California B.A.C.T. rating. Includes a *National Electrical Code*-compliant 3- or 4-pole generator with UL 1446 insulation, digital engine and generator monitoring, metering and protection with ground fault interruption and lightning shielding, R448 voltage regulator, RFI filter, Woodward API 611 governor and overspeed valve relay, paralleling and synchronizing automatic transfer switch or (for standby emergencies) automatic dual lockout automatic transfer switch, fused main circuit breaker, electronic load-sharing module for generator ganging, electric starter motor, battery, and trickle charger, lube oil cooling system with radiator and fan, oil pump and sump, water cooling system with water pump, radiator and fan, mounting skid, sound- and weather-proof enclosure, turbine inlet air filter, stainless steel exhaust silencer and stack, natural gas fuel train with diaphragm regulator valve, modulating metering valve, pressure gauge and flowmeter, liquid fuel train with fuel pump, fuel preheater, day tank with level gauge, main dual-fuel engine inlet regulating valve, remote annunciation panel with alarms and warning lights, and NFPA-rated CO₂ fire extinguishing system. Add the cost of approval of prints by an inspection bureau, connecting electrical loads and electrical controls, a concrete pad for mounting on the ground or structural steel supports for mounting on a roof, grouting, precision leveling, startup, commissioning, and post-construction inspection by insurance and fire inspectors. These figures assume turbine exhaust heat is released into the atmosphere. Suitable for standby or primary power generation for commercial and light to heavy industrial applications, schools, hospitals, government and institutional use and utility peak-shaving service. Equipment cost is for a 2-ton capacity crane.

1,000 KW electrical output	D6@80.0	Ea	1,180,000.00	4,440.00	2,360.00	1,186,800.00
3,500 KW electrical output	D6@80.0	Ea	4,170,000.00	4,440.00	2,450.00	4,176,890.00
5,000 KW electrical output	D6@120	Ea	5,930,000.00	6,660.00	3,670.00	5,940,330.00
6,000 KW electrical output	D6@120	Ea	7,150,000.00	6,660.00	3,670.00	7,160,330.00
7,500 KW electrical output	D6@160	Ea	11,300,000.00	8,880.00	5,000.00	11,313,880.00

26 Electrical

Add-on heat recovery system for gas turbine generators. Add these costs to the appropriate gas turbine generator costs above when exhaust heat will be used to drive a 60 PSI hot water to 600 PSI steam boiler which is part of the building HVAC system. Includes a D- or A-Type watertube bundle, superheater and mud drums, primary stack, secondary stack with service exhaust gas sealed damper bypass plenum, temperature, pressure and level gauges, duplex boiler feed pump, auxiliary dual-fuel continuously-modulating burner, digital burner control and ignition annunciator panel with alarms, condensate return or circulating pump loop, main valve, twin pressure relief valves with vent, drain line, thermally and acoustically insulated enclosure extension, chemical feedwater treatment tank, pump with bladed mixer and relay valve. By pounds for per hour (PPH) rating, hot water or steam. Equipment cost is for a 2-ton capacity crane.

	Craft@Hrs	Unit	Material	Labor	Equipment	Total
3,000 PPH (1,000 KW turbine generator)	D6@80.0	Ea	241,000.00	4,440.00	2,360.00	247,800.00
10,500 PPH (3,500 KW turbine generator)	D6@80.0	Ea	822,000.00	4,440.00	2,360.00	828,800.00
15,000 PPH (5,000 KW turbine generator)	D6@120	Ea	1,210,000.00	6,660.00	3,560.00	1,220,220.00
18,000 PPH (6,000 KW turbine generator)	D6@120	Ea	1,410,000.00	6,660.00	3,560.00	1,420,220.00
22,500 PPH (7,500 KW turbine generator)	D6@160	Ea	2,240,000.00	8,880.00	5,390.00	2,254,270.00
34,500 PPH (11,500 KW turbine generator)	D6@160	Ea	3,180,000.00	8,880.00	5,390.00	3,194,270.00

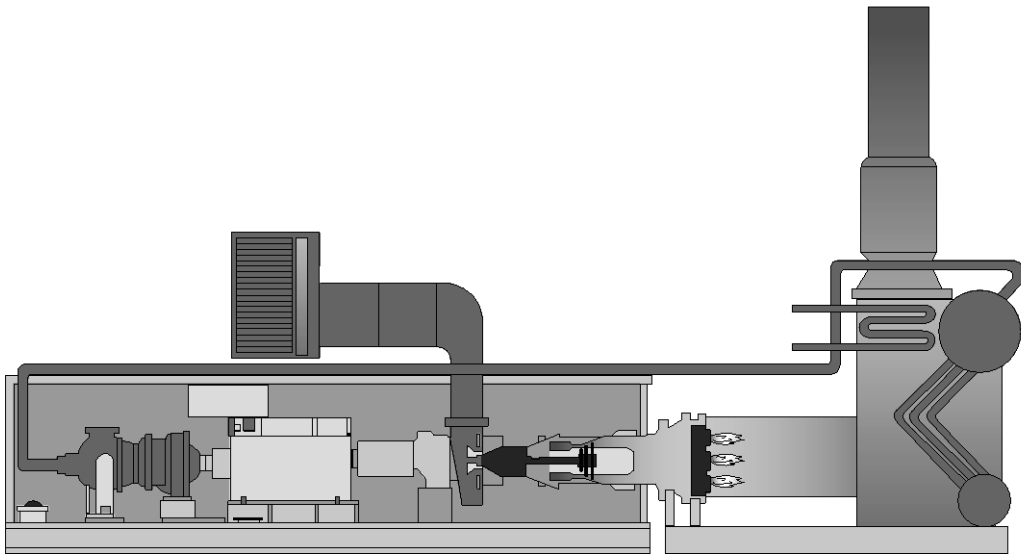

COMBINED CYCLE GAS TURBINE

Add for combined cycle gas turbine heat recovery generator sets. These costs assume exhaust heat drives a turbo generator for electric power cogeneration. Combined cycle operations increase generating capacity by approximately 20% over simple cycle gas turbine generators. Includes the steam turbo generator, backpressure single stage with Woodward API 611 governor and overspeed cutoff valve, main inlet throttling valve, *National Electrical Code*-compliant 4-pole 480 volt, 60 HZ, 3-phase electrical generator with paralleling and synchronizing automatic transfer switch, main breaker with ground fault interruption and lightning protection, ambient forced and air-cooled fintube coil and fan condenser array with condensate pump and return line, bypass drain, emergency vent to atmosphere, digital and thermostatically controlled annunciator panel with pressure/temp/flow rate metering, alarms and emergency cutoff capabilities in a NEMA 10 (wet environment) enclosure. Add the cost of electrical connection and control tie-in, grouting, precision equipment leveling, concrete pad or structural steel roof mount support, vibration isolation mounts, permitting, approvals or inspection. For a combined cycle gas turbine heat recovery generator, add the following percentages to the combined cost of the appropriate gas turbine generator set and matching heat recovery system.

	Craft@Hrs	Unit	Material	Labor	Equipment	Total
Add for power generation driven by exhaust heat	—	%	30.0	50.0	105.00	—

26 Electrical

	Craft@Hrs	Unit	Material	Labor	Equipment	Total
Power generator exhaust stack Plate steel exhaust stack for high mass flow rate power generators. Mill-rolled, seam-welded and shop fabricated for field erection. Stack has ionically-bonded internal silicon lining with external aluminized coating, external spiral windbreaker banding, two gasketed and bolted flanges per stack section, buttressed base support sleeve, inlet and service bypass. T-plenum includes a soundproofing enclosure and structural steel support frame. Mounting includes a vibration-isolating spring-loaded circular base plus concrete-anchored guy wiring, eyelets and adjustable guy wire extension tensioners. Add the cost of a reinforced 3000 P.S.I. laser-leveled concrete pad. Equipment cost is for rental of a 3-ton 200-foot extensible truck mounted cable-drive spider gantry crane. Cost per stack section. Each exhaust assembly includes one T-plenum and enough stack sections to meet code requirements and manufacturer specifications. Typical stack height is 75' to 200'. Labor costs assume half of the stack is erected in place upright. The balance is assembled on the ground and lifted into place with a spider crane.						
10" diameter stack T-plenum with frame	D5@36.0	Ea	20,000.00	1,870.00	—	21,870.00
16" diameter stack T-plenum with frame	D5@36.0	Ea	26,300.00	1,870.00	—	28,170.00
20" diameter stack T-plenum with frame	D5@40.0	Ea	34,400.00	2,080.00	—	36,480.00
24" diameter stack T-plenum with frame	D5@48.0	Ea	41,100.00	2,490.00	—	43,590.00
30" diameter stack T-plenum with frame	D5@60.0	Ea	46,200.00	3,120.00	—	49,320.00
48" diameter stack T-plenum with frame	D5@72.0	Ea	55,800.00	3,740.00	—	59,540.00
60" diameter stack T-plenum with frame	D5@96.0	Ea	66,200.00	4,990.00	—	71,190.00
72" diameter stack T-plenum with frame	D5@120	Ea	103,000.00	6,230.00	—	109,230.00
96" diameter stack T-plenum with frame	D5@160	Ea	143,000.00	8,310.00	—	151,310.00
132" diameter stack T-plenum with frame	D5@180	Ea	292,000.00	9,350.00	—	301,350.00
10" diameter stack, 10' high section	D6@24.0	Ea	994.00	1,330.00	4,880.00	7,204.00
16" diameter stack, 10' high section	D6@24.0	Ea	1,170.00	1,330.00	4,880.00	7,380.00
20" diameter stack, 10' high section	D6@24.0	Ea	1,600.00	1,330.00	4,880.00	7,810.00
24" diameter stack, 10' high section	D6@32.0	Ea	2,120.00	1,780.00	4,880.00	8,780.00
30" diameter stack, 10' high section	D6@32.0	Ea	2,520.00	1,780.00	4,880.00	9,180.00
48" diameter stack, 10' high section	D6@32.0	Ea	2,920.00	1,780.00	4,880.00	9,580.00
60" diameter stack, 20' high section	D6@40.0	Ea	3,980.00	2,220.00	7,220.00	13,420.00
72" diameter stack, 20' high section	D6@40.0	Ea	4,760.00	2,220.00	7,220.00	14,200.00
96" diameter stack, 20' high section	D6@40.0	Ea	5,030.00	2,220.00	7,220.00	14,470.00
132" diameter stack, 20' high section	D6@80.0	Ea	5,960.00	4,440.00	7,220.00	17,620.00
Pollution control modules for gas turbine generators. NOx, SOx, VM (volatile materials) and particle emissions reduction wet module, free-standing, simple cycle. For natural gas fired prime (baseload) power and standby emergency electrical generators. Verantis, Croll-Reynolds, or equal. Complies with 2010 California Code, Tier IV, EPA and European ISO standards. Either vertical counter-flow or packed-bed wet type. For commercial and light to heavy industrial applications, schools, hospitals, and governmental/institutional applications and utility peak-shaving about 15% to the total cost, including a second stage, a second stage pump, venturi particulate separator and sludge tank. To calculate the annual lease rate for a complete installation, divide the total installed cost by five. Then add 2% per year to cover vendor-supplied maintenance.						
1,000 KW electrical	U1@69.0	Ea	87,900.00	3,540.00	—	91,440.00
3,500 KW electrical	U1@69.0	Ea	145,000.00	3,540.00	—	148,540.00
5,000 KW electrical	U1@69.0	Ea	176,000.00	3,540.00	—	179,540.00
6,000 KW electrical	U1@69.0	Ea	187,000.00	3,540.00	—	190,540.00
7,500 KW electrical	U1@69.0	Ea	207,000.00	3,540.00	—	210,540.00
11,500 KW electrical	U1@69.0	Ea	292,000.00	3,540.00	—	295,540.00
Installation costs for pollution control modules for gas turbine generators.						
Position main housing, fans and pumps	U1@4.00	Ea	—	205.00	—	205.00
Tie-down and leveling	U1@4.00	Ea	575.00	205.00	—	780.00
Mount piping system frame supports	U1@6.00	LF	1.73	308.00	—	309.73

26 Electrical

	Craft@Hrs	Unit	Material	Labor	Equipment	Total
Rig and mount plenum and ducts	SM@5.00	Ea	—	306.00	—	306.00
Rig and mount tank for emission reduction fluid and housing inlet metering valve	U1@4.00	Ea	—	205.00	—	205.00
Weld systems piping	U1@8.00	LF	2.42	411.00	—	413.42
Wire electrical system	BE@8.00	LF	2.08	328.00	—	330.08
Wire controls system	BE@16.0	LF	2.19	656.00	—	658.19
Rotating equipment system level & balance	P1@8.00	Ea	231.00	298.00	—	529.00
Calibration & test	U1@2.00	Ea	—	103.00	—	103.00
Witnessed run trials (add the permit fee)	P1@4.00	Ea	—	149.00	—	149.00

Integrated Photovoltaic Systems For light commercial, government and institutional applications. In arrays of from 50 to 200 KW-hour capacity. Façade, skylight or vertically mounted (integrated into glazing). Includes photovoltaic modules (thin-film or polycrystalline/crystalline ribbon, or amorphous silicon), a charge controller to regulate the power into and out of the battery storage bank (in stand-alone systems), a power storage system or utility grid integration, an inverter to convert DC output to AC, appropriate support and mounting hardware, wiring, and safety disconnects. Thin film single crystal cells are laser-etched and vapor deposited into 2-pane 5/8" to 1" glazing. Polycrystalline or crystalline ribbon solar cells and amorphous silicon solar cells are opaque and are used most commonly for retrofit roof, pergola and canopy mounting. A 6 SF solar unit has 36 cells in an 18" x 4' panel with a 4" x 4" junction box. Add the cost of the permit, roof load resistance and façade deflection reinforcement and standby power generator, if required. Complies with Federal Spec 48 14 00.

	Craft@Hrs	Unit	Material	Labor	Total
Vertical framing mullions, 11 ga. x 1" x 3", aluminum	IW@.009	Lb	1.52	.60	2.12
Horizontal framing mullions, 11 ga. x 2" x 3", aluminum with galvanized steel internal bracing	IW@.019	Lb	2.53	1.27	3.80
Thin film single crystal solar cells	G1@.045	SF	107.00	2.20	109.20
Polycrystalline or crystalline ribbon solar cells	G1@.035	SF	97.60	1.71	99.31
Amorphous solar cells	G1@.035	SF	38.50	1.71	40.21
Add for thermally reflective or retentive coatings	—	%	15.0	—	—
Charge controller with fusing and emergency interrupts, 2.25 watt-hour	E4@4.0	Ea	206.00	205.00	411.00
Power storage system, utility grid paralleling switchgear and service bypass, 2.20 watt-hour	E4@8.0	Ea	411.00	411.00	822.00
Battery pack and fault protection, 6.00 watt-hour	E4@2.0	Ea	332.00	103.00	435.00
DC to AC inverter with power quality system filters, 1.85 watt-hour	E4@16.0	Ea	823.00	821.00	1,644.00
Electrical wiring for integrated PV system	E4@.007	LF	.52	.36	.88
Inspection and test of integrated PV system	E4@8.0	Ea	—	411.00	411.00
Typical installed cost per SF of cell (1.5 watts), including poly cells, supports, charge controller, power storage, grid interconnect, inverter, wiring, inspection and test, 50 to 200 KW array	—	LS	—	—	105.30
Add for architectural services and approvals	—	%	—	—	10.0

Fluorescent Lighting Commercial, industrial and architectural grade. Rapid start. With ballasts but no lamps, wire or conduit. Includes setting and connecting prewired fixtures only.

Surface mounted fluorescent fixtures, better quality, baked enamel finish, with hinged wraparound acrylic prismatic lens suitable for office or classroom use, 4' long, Lithonia LB series

Two 40 watt lamp fixture (#240-A)	CE@.773	Ea	87.50	47.20	134.70
Four 40 watt lamp fixture (#440-A)	CE@.773	Ea	164.00	47.20	211.20
Eight 40 watt lamp fixture, 8' long (#8T440-A)	CE@.960	Ea	250.00	58.60	308.60
Surface mounted fluorescent fixtures, baked enamel finish, with wraparound acrylic prismatic lens suitable for industrial use, 4' long, Lithonia series					
One 40 watt lamp fixture (CB140A)	CE@.806	Ea	78.10	49.20	127.30
Two 40 watt lamp fixture (LB240A)	CE@.858	Ea	67.10	52.30	119.40
Four 40 watt lamp fixture (LB440A)	CE@1.07	Ea	114.00	65.30	179.30
Add for 40 watt lamps	—	Ea	4.31	—	4.31

26 Electrical

	Craft@Hrs	Unit	Material	Labor	Total
Surface mounted steel sided fluorescent fixtures with acrylic prismatic diffuser, 7-1/16" x 4-1/2"					
Two 40 watt lamps	CE@.955	Ea	95.50	58.30	153.80
Four 40 watt lamps	CE@1.05	Ea	134.00	64.10	198.10
Add for 40 watt straight lamps	—	Ea	4.32	—	4.32
Wall surface mounted fluorescent fixtures, baked enamel finish, 2 lamps, 8" wide 5" high, hinged acrylic prismatic lens, Lightolier					
26" long fixture	CE@.737	Ea	200.00	45.00	245.00
38" long fixture	CE@.795	Ea	233.00	48.50	281.50
50" long fixture	CE@.858	Ea	225.00	52.30	277.30
Add for 24" 20 watt lamps	—	Ea	3.92	—	3.92
Add for 36" 30 watt lamps	—	Ea	6.11	—	6.11
Add for 48" 40 watt lamps	—	Ea	2.79	—	2.79
Industrial pendent or surface mounted open striplights, baked enamel finish, Lithonia C series					
One or two 40 watt lamps, 4' long (C240)	CE@.865	Ea	45.30	52.80	98.10
One or two 75 watt lamps, 8' long (C296)	CE@1.02	Ea	67.10	62.20	129.30
One or two 55 watt lamps, 6' long (C272)	CE@1.02	Ea	67.10	62.20	129.30
Add for 40 watt lamps	—	Ea	3.01	—	3.01
Add for 75 or 55 watt lamps	—	Ea	7.12	—	7.12
Add for 24" stem and canopy set, per fixture	—	Ea	7.38	—	7.38
Industrial pendent or surface mounted fluorescent fixtures, 12" wide baked enamel, steel reflector-shield, Lithonia L/LA series					
Two 40 watt lamps, 4' long (L-240-120)	CE@.903	Ea	48.70	55.10	103.80
Two 75 watt lamps, 8' long (L-296-120)	CE@1.21	Ea	95.50	73.80	169.30
Add for 40 watt lamps	—	Ea	3.01	—	3.01
Add for 75 watt lamps	—	Ea	7.18	—	7.18
Ceiling grid mounted fluorescent troffer fixtures, baked enamel finish, with hinged acrylic prismatic lens with energy saving ballast, Day-Brite					
Two 40 watt "U" lamp fixture, 2' x 2'	CE@.908	Ea	70.60	55.40	126.00
Two 40 watt lamp fixture, 2' x 4'	CE@.998	Ea	80.00	60.90	140.90
Four 40 watt lamp fixture, 2' x 4'	CE@1.05	Ea	86.50	64.10	150.60
Add for plaster frames, per fixture	—	Ea	10.30	—	10.30
Air-handling grid mounted floating door, heat transfer troffer fixtures with acrylic lens, no ductwork included					
1' x 4', two 40 watt lamps	CE@.908	Ea	134.00	55.40	189.40
2' x 2', one U-shape 40 watt lamp	CE@.809	Ea	142.00	49.40	191.40
2' x 4', two 40 watt lamps	CE@1.00	Ea	177.00	61.00	238.00
2' x 4', three 40 watt lamps	CE@1.05	Ea	220.00	64.10	284.10
2' x 4', four 40 watt lamps	CE@1.05	Ea	220.00	64.10	284.10
Add for 40 watt 4' lamps	—	Ea	3.01	—	3.01
Add for 40 watt "U" lamps	—	Ea	12.60	—	12.60
Surface mounted vandal-resistant luminaire with tamper-resistant screw-type latching, Sylvania					
1 lamp	CE@.761	Ea	147.00	46.40	193.40
2 lamps	CE@.761	Ea	150.00	46.40	196.40
4 lamps	CE@.761	Ea	252.00	46.40	298.40
Parabolic fluorescent luminaire, 6" x 24" x 24" with semi-specular anodized aluminum reflector and parabolic louvers, I.C.E. AR series					
Two 40 watt lamp, bracket or pendent mount	CE@.955	Ea	92.80	58.30	151.10
Four 40 watt lamps, bracket or pendent mount	CE@.955	Ea	148.00	58.30	206.30
Round surface mounted fluorescent fixtures, aluminum housing, matte black finish, polycarbonate or acrylic opal globe, Circleline					
22 to 32 watt, 14" diameter	CE@.478	Ea	58.30	29.20	87.50
32 to 40 watt, 18" diameter	CE@.478	Ea	80.80	29.20	110.00
Add for circline tubes	—	Ea	8.92	—	8.92



26 Electrical

	Craft@Hrs	Unit	Material	Labor	Total
Outdoor sign fluorescent fixtures, anodized aluminum housing with parabolic specular reflector and acrylic lens, with high output lamps and remote ballast					
One 60 watt lamp, 48" long fixture	CE@2.39	Ea	275.00	146.00	421.00
One 85 watt lamp, 72" long fixture	CE@2.39	Ea	290.00	146.00	436.00
One 110 watt lamp, 96" long fixture	CE@2.39	Ea	320.00	146.00	466.00
Two 85 watt lamps, 144" long fixture	CE@2.39	Ea	434.00	146.00	580.00
Add for high output T12 800 MA lamps, sign white					
60 watt	—	Ea	8.27	—	8.27
85 watt	—	Ea	8.32	—	8.32
115 watt	—	Ea	23.20	—	23.20
Cost per linear foot of fixture	CE@.179	LF	73.00	10.90	83.90
Add for 90-degree elbows	CE@.475	Ea	191.00	29.00	220.00
Add for in-line connectors	CE@.475	Ea	95.80	29.00	124.80
Wet or damp location surface mounted fluorescent fixtures, hinge mounted acrylic diffuse lens, fiberglass or plastic housing with gaskets, Hubbell					
Two 40 watt lamps, 4' long fixture	CE@1.21	Ea	159.00	73.80	232.80
Two 40 watt lamps, 8' long fixture	CE@1.86	Ea	345.00	113.00	458.00
Add for 40 watt lamps	—	Ea	2.94	—	2.94
Commercial and industrial LED light fixtures					
With lamps but no wire or conduit. Labor includes setting and connecting prewired fixtures only.					
Recessed-LED 12 volt accent lights, aluminum reflector, 2-1/2" glass lens and pigtail connection, dimmable					
1 watt	CE@1.15	Ea	18.10	70.20	88.30
5 watt	CE@1.15	Ea	27.30	70.20	97.50
6 watt, waterproof	CE@1.15	Ea	54.70	70.20	124.90
Recessed LED downlight, 100 to 240 volt, frosted dome lens, white baffle trim, dimmable					
5" dia. 9 W, 60 W equivalent	CE@1.21	Ea	24.30	73.80	98.10
6" dia. 15 W, 75 W equivalent	CE@1.21	Ea	27.30	73.80	101.10
8" dia. 24 W, 190 W equivalent	CE@1.21	Ea	21.70	73.80	95.50
6" square, 9 W, 60 W equivalent	CE@1.21	Ea	16.40	73.80	90.20
Flush mount-LED ceiling lights, frosted dome lens, white aluminum trim, dimmable					
5-1/2" dia. 10 W, 60 W equivalent	CE@1.21	Ea	18.10	73.80	91.90
7" dia. 12 W, 75 W equivalent	CE@1.21	Ea	18.10	73.80	91.90
9" dia. 18 W, 100 W equivalent	CE@1.21	Ea	21.70	73.80	95.50
13" dia. 25 W, 100 W equivalent	CE@1.21	Ea	21.70	73.80	95.50
16" dia. 23 W, 100 W, bronze trim	CE@1.21	Ea	54.20	73.80	128.00
14" square, 10 W, 60 W equivalent	CE@1.21	Ea	21.70	73.80	95.50
LED panel lights, frosted dome lens, white aluminum trim, dimmable					
5-1/2" dia. 10 W, 60 W equivalent	CE@1.21	Ea	18.10	73.80	91.90
7" dia. 12 W, 75 W equivalent	CE@1.21	Ea	18.10	73.80	91.90
9" dia. 18 W, 100 W equivalent	CE@1.21	Ea	21.70	73.80	95.50
13" dia. 25 W, 100 W equivalent	CE@1.21	Ea	21.70	73.80	95.50
16" dia. 23 W, 100 W, bronze trim	CE@1.21	Ea	54.20	73.80	128.00
14" square, 10 W, 60 W equivalent	CE@1.21	Ea	21.70	73.80	95.50

26 Electrical

	Craft@Hrs	Unit	Material	Labor	Total
Industrial LED wall packs, aluminum housing, bronze finish, polycarbonate lens, weatherproof, with lamps.					
20 watt, 70 W halide equivalent	CE@.955	Ea	37.00	58.30	95.30
28 watt, 70 W halide equivalent	CE@.955	Ea	49.30	58.30	107.60
40 watt, 250 W halide equivalent	CE@.955	Ea	95.30	58.30	153.60
80 watt, 400 W halide equivalent	CE@.955	Ea	106.00	58.30	164.30
80 watt, 400 W halide equivalent, rotatable	CE@.955	Ea	148.00	58.30	206.30
120 watt, 400 W halide equivalent	CE@.955	Ea	138.00	58.30	196.30
Add for photo cell control, factory-installed	—	Ea	15.40	—	15.40
High-bay LED industrial fixture, cast aluminum housing, 10" diameter tempered glass lens, suspended or surface mounted, with lamp, U-bracket, eye hook, and safety cable.					
100 watt, 250 W halide equivalent	CE@1.30	Ea	159.00	79.30	238.30
150 watt, 400 W halide equivalent	CE@1.30	Ea	191.00	79.30	270.30
200 watt, 750 W halide equivalent	CE@1.30	Ea	222.00	79.30	301.30
300 watt, 1000 W halide equivalent	CE@1.30	Ea	328.00	79.30	407.30
400 watt, 1500 W halide equivalent	CE@1.30	Ea	540.00	79.30	619.30
500 watt, 1500 W halide equivalent	CE@1.30	Ea	646.00	79.30	725.30
Add for wire guard on lens	CE@.250	Ea	80.40	15.30	95.70
High-bay LED linear fixtures, white aluminum frame, frosted poly lens, suspension mount, by metal halide lamp equivalent					
80 watt, 3 lamps, 24" x 12", 250 W halide	CE@1.39	Ea	95.30	84.80	180.10
100 watt, 4 lamps, 48" x 12", 250 W halide	CE@1.39	Ea	84.70	84.80	169.50
110 watt, 3 lamp, 24" x 12", 320 W halide	CE@1.39	Ea	106.00	84.80	190.80
150 watt, 4 lamps, 48" x 12", 250 W halide	CE@1.39	Ea	106.00	84.80	190.80
165 watt, 4 lamps, 24" x 12", 400 W halide	CE@1.39	Ea	164.00	84.80	248.80
225 watt, 6 lamp, 48" x 12", 400 W halide	CE@1.39	Ea	185.00	84.80	269.80
250 watt, 8 lamps, 48" x 20", 400 W halide	CE@1.39	Ea	252.00	84.80	336.80
300 watt, 10 lamp, 48" x 20", 1000 W halide	CE@1.39	Ea	292.00	84.80	376.80
Add for conduit mounting	CE@.250	Ea	7.29	15.30	22.59
Add for emergency driver, 25 W backup power for 90 minutes, with test switch	CE@1.71	Ea	148.00	104.00	252.00
LED area flood light fixtures, U-bracket mount, aluminum frame, poly lens, weatherproof					
30 watt, 150 W halide equivalent, 4" x 6"	CE@1.07	Ea	37.00	65.30	102.30
50 watt, 175 W halide equivalent	CE@1.07	Ea	52.90	65.30	118.20
100 watt, 250 W halide equivalent	CE@1.07	Ea	127.00	65.30	192.30
150 watt, 400 W halide equivalent	CE@1.07	Ea	180.00	65.30	245.30
200 watt, 600 W halide equivalent, 18" x 14"	CE@1.07	Ea	212.00	65.30	277.30
Vapor tight LED light fixtures, weatherproof aluminum housing and impact-resistant frosted polycarbonate lens. For use in harsh environments: gas stations, car washes, industrial kitchens, loading docks.					
30 watt, 2' long	CE@1.07	Ea	74.10	65.30	139.40
50 watt, 4' long	CE@1.21	Ea	117.00	73.80	190.80
60 watt, 4' long	CE@1.21	Ea	138.00	73.80	211.80
20 watt caged jelly jar fixture	CE@1.07	Ea	84.70	65.30	150.00
Incandescent Lighting Commercial and architectural grade. No wire, conduit or concrete included. Includes setting and connecting prewired fixtures only.					
Step illumination light fixtures, 16 gauge steel housing with white enamel finish, 5" high, 4" deep, 11" long					
Polycarbonate or tempered glass lens fixture	CE@1.07	Ea	233.00	65.30	298.30
Louvered sheet metal front fixture	CE@1.07	Ea	191.00	65.30	256.30
Add for brushed aluminum trim, 2 lamps	—	Ea	53.10	—	53.10
Wall surface mounted fluorescent fixtures, baked enamel finish, 2 lamps, 8" wide 5" high, hinged acrylic prismatic lens, Lightolier					
26" long fixture	CE@.737	Ea	195.00	45.00	240.00
38" long fixture	CE@.795	Ea	226.00	48.50	274.50
50" long fixture	CE@.858	Ea	218.00	52.30	270.30

26 Electrical

	Craft@Hrs	Unit	Material	Labor	Total
Add for 24" 20 watt lamps	—	Ea	3.99	—	3.99
Add for 36" 30 watt lamps	—	Ea	6.19	—	6.19
Add for 48" 40 watt lamps	—	Ea	2.82	—	2.82
Recessed round eyelid wall wash, 6" milligroove baffle, Prescolite 150 watt fixture	CE@1.07	Ea	189.00	65.30	254.30
Exterior wall fixtures, cast anodized aluminum with white polycarbonate globe, gaskets between globe and housing and between housing and base, Prescolite					
Cylinder globe fixture 	CE@.320	Ea	101.00	19.50	120.50
Round globe fixture 	CE@.430	Ea	33.10	26.20	59.30
Add for 100 watt lamp	—	Ea	5.50	—	5.50
Add for 150 watt lamp	—	Ea	5.59	—	5.59
Obstruction light, meets Federal Aviation Administration Specification L-810, cast aluminum housing, two one-piece red, heat-resistant fresnel globes, with photoelectric control, mounted on 1" rigid steel conduit, including junction box and mounting plate					
Two 100 watt lamp fixture	CE@4.91	Ea	166.00	300.00	466.00
Vandal-Resistant Lighting Commercial and architectural grade. Includes setting and connecting prewired fixtures but no wire, conduit or lamps.					
Ceiling mounted 12" x 12" x 6" fixture, polycarbonate prismatic lens					
Two 100 watt incandescent lamps	CE@.764	Ea	108.00	46.60	154.60
22 watt fluorescent circline lamp	CE@.955	Ea	79.10	58.30	137.40
Wall mounted 6" wide, 9" high, 7" deep fixture, polycarbonate prismatic diffuser					
One 100 watt incandescent lamp	CE@.572	Ea	78.10	34.90	113.00
13 watt fluorescent lamp	CE@.764	Ea	124.00	46.60	170.60
Lamps for vandal-resistant fixtures					
100 watt incandescent lamp	—	Ea	5.59	—	5.59
13 watt fluorescent lamp	—	Ea	11.60	—	11.60
35 to 70 watt high pressure sodium lamp	—	Ea	83.20	—	83.20
Lighted Exit Signs Includes setting and connecting prewired fixtures but no wire or conduit.					
Universal mount (wall or ceiling), Thinline series, 6" letters on one side, stencil face					
Single	CE@.764	Ea	34.80	46.60	81.40
Twin	CE@.764	Ea	34.80	46.60	81.40
Universal mount, 6" letters on two sides of polycarbonate housing, two 15 watt lamps					
	CE@.764	Ea	54.30	46.60	100.90
Add for two circuit supply	—	Ea	11.20	—	11.20
Add for 24" stem hanger	—	Ea	15.40	—	15.40
Add for battery backup for exit signs	CE@.381	Ea	25.30	23.20	48.50
Explosion-Proof Lighting					
No wire, conduit or concrete included. Includes setting and connecting prewired fixtures only.					
Explosion proof LED light fixtures, rated for Class 1 Division 2 hazards (granaries, mills, mines, gas stations, airplane hangars, auto shops) cast aluminum housing, U-bracket mount, tempered glass lens					
100 watt, 175 W halide equivalent 	CE@2.57	Ea	636.00	157.00	793.00
200 watt, 400 W halide equivalent	CE@2.57	Ea	954.00	157.00	1,111.00
Explosion proof LED light fixtures, rated for Class 1 Division 1 hazards (vapors and gases are constantly present, i.e. paint spray booth) cast aluminum housing, U-bracket mount, tempered glass lens					
150 watt, 175 W halide equivalent	CE@2.57	Ea	1,780.00	157.00	1,937.00

26 Electrical

	Craft@Hrs	Unit	Material	Labor	Total
Emergency Lighting Includes setting and connecting prewired fixtures but no wire or conduit.					
Shelf or wall mounted solid state battery pack with charger, lead-acid battery, baked enamel finish, with 2 halogen lamps, 90 minute operation, indoor use only					
6 volt, 15 watt	CE@1.74	Ea	127.00	106.00	233.00
6 volt, 30 watt	CE@1.74	Ea	196.00	106.00	302.00
6 volt, 50 watt	CE@1.74	Ea	230.00	106.00	336.00
6 volt, 100 watt	CE@1.74	Ea	309.00	106.00	415.00
12 volt, 100 watt	CE@1.74	Ea	312.00	106.00	418.00
Self diagnostic emergency lighting fixtures, microprocessor based, continuously monitors battery/lamps					
Emergency fixture, two lamps, wall mount	CE@.825	Ea	235.00	50.30	285.30
LED exit sign with emergency fixture, wall mount	CE@.825	Ea	414.00	50.30	464.30
LED exit sign only, wall mount	CE@.825	Ea	354.00	50.30	404.30

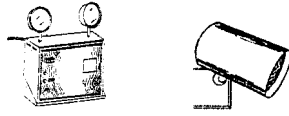

	Craft@Hrs	Unit	Material	Labor	Equipment	Total
--	-----------	------	----------	-------	-----------	-------

Yard and Street Lighting Includes setting and connecting prewired fixtures with ballast but no pole, concrete work, excavation, wire, lamps or conduit. See pole costs below. Equipment is a flatbed truck with a boom & auger

Rectangular LED floodlights, die-cast aluminum housing, tempered glass lens, photoelectric cell, add the cost of mounting pole or bracket

100 watt, 250 W halide equivalent	E1@1.55	Ea	185.00	81.60	25.10	291.70
150 watt, 400 W halide equivalent	E1@1.55	Ea	201.00	81.60	25.10	307.70
200 watt, 750 W halide equivalent	E1@1.55	Ea	249.00	81.60	25.10	355.70
300 watt, 1,000 W halide equivalent	E1@1.55	Ea	344.00	81.60	25.10	450.70
Add for pole mount kit	E1@.547	Ea	15.80	28.80	8.85	53.45
Add for wall mount bracket	E1@.547	Ea	31.70	28.80	8.85	69.35

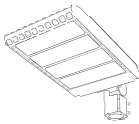

Canopy-mounted LED floodlights, die-cast anodized aluminum housing with shatterproof polycarbonate lens, flush or surface mount. Security lighting for parking garages, gas stations, drive-thrus and covered walkways.

60 watt, 100 W halide equivalent	E1@2.71	Ea	74.10	143.00	43.90	261.00
100 watt, 250 W halide equivalent	E1@2.71	Ea	90.00	143.00	43.90	276.90
150 watt, 400 W halide equivalent	E1@2.71	Ea	115.00	143.00	43.90	301.90

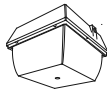

Yard and Street Lighting Poles

Hole for a pole foundation dug with a truck-mounted auger, no soil disposal included

Per CF of undisturbed soil	E1@.064	CF	—	3.37	1.04	4.41
----------------------------	---------	----	---	------	------	------

Concrete pole foundations, formed, poured and finished, with anchor bolts. Material costs shown include concrete, forms and anchor bolts

12" diameter, 36" deep, for 12' pole	E1@.746	Ea	45.00	39.30	12.10	96.40
24" diameter, 72" deep, for 30' pole	E1@1.14	Ea	180.00	60.00	18.50	258.50
30" diameter, 76" deep, for 40' pole	E1@1.54	Ea	233.00	81.10	24.90	339.00

Yard and street light poles, including base plate but no top brackets. See labor costs below.

	Unit	Round steel	Square steel	Aluminum
12' high	Ea	954.00	621.00	332.00
16' high	Ea	1,120.00	727.00	415.00
20' high, 6" wide	Ea	1,510.00	917.00	587.00
25' high, 6" wide	Ea	1,830.00	1,120.00	1,300.00
30' high, 8" wide	Ea	2,110.00	1,700.00	1,470.00
35' high, 8" wide	Ea	2,720.00	2,130.00	2,270.00
40' high, 9" wide	Ea	3,160.00	2,400.00	2,600.00
50' high, 10" wide	Ea	3,550.00	3,500.00	—

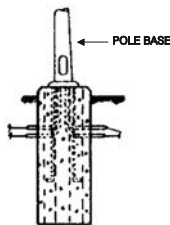

26 Electrical

	Craft@Hrs	Unit	Material	Labor	Equipment	Total
Labor setting metal light poles Equipment is a flatbed truck with a boom & auger						
To 20' high	E1@2.89	Ea	—	152.00	46.80	198.80
25' to 30' high	E1@4.35	Ea	—	229.00	70.42	299.42
35' to 40' high	E1@5.73	Ea	—	302.00	92.80	394.80
50' high	E1@8.57	Ea	—	451.00	139.00	590.00
Deduct for aluminum poles	—	%	—	-20.0	-20.0	—
Top brackets for steel and aluminum light poles, installed prior to setting pole						
Single arm	CE@.500	Ea	118.00	30.50	8.09	156.59
Two arm	CE@.500	Ea	140.00	30.50	8.09	178.59
Three arm	CE@.991	Ea	180.00	60.50	16.00	256.50
Four arm	CE@.991	Ea	225.00	60.50	16.00	301.50

Area Lighting, Installed on Poles

These costs include excavation for pole, pole foundation (2' x 2' x 3' deep), 150' of 2" PVC conduit run with 40' of RSC, 600' of #8 copper wire and terminations, 35' x 8" square steel pole and one arm and a 300 watt LED (1,000 watt metal halide equivalent) lamp for each fixture. Equipment is a flatbed truck with a boom and auger.

Cost per pole including fixtures as shown

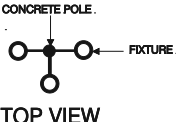
1 fixture per pole		E1@30.4	Ea	4,060.00	1,600.00	492.00	6,152.00
2 fixtures per pole		E1@32.5	Ea	4,310.00	1,710.00	526.00	6,546.00
3 fixtures per pole		E1@34.8	Ea	4,550.00	1,830.00	563.00	6,943.00
4 fixtures per pole		E1@36.8	Ea	4,800.00	1,940.00	596.00	7,336.00

27 Communications

	Craft@Hrs	Unit	Material	Labor	Total
Security and Alarm Systems Sensor costs include connection but no wire runs.					
Monitor panels, including accessory section and connection to signal and power supply wiring, cost per panel					
1 zone wall-mounted cabinet with 1 monitor panel, tone, standard line supervision, and 115 volt power supply	E4@2.02	Ea	1,070.00	104.00	1,174.00
5 zone wall-mounted cabinet with 5 monitor panels, 10 zone monitor rack, 5 monitor panel blanks, tone, standard line supervision and 115 volt power supply	E4@8.21	Ea	6,090.00	422.00	6,512.00
10 zone wall-mounted cabinet with 10 monitor panels, 10 zone monitor rack, tone, standard line supervision and 115 volt power supply	E4@12.1	Ea	6,990.00	621.00	7,611.00
10 zone monitor rack and 10 monitor panels with tone and standard line supervision but no power supply and no cabinet	E4@11.1	Ea	5,780.00	570.00	6,350.00
1 zone wall-mounted cabinet with 1 monitor panel, tone, high security line supervision and 115 volt power supply	E4@2.02	Ea	1,440.00	104.00	1,544.00
high security line supervision but no power supply	E4@7.82	Ea	7,580.00	401.00	7,981.00
10 zone wall-mounted cabinet with 10 monitor panels, 10 zone monitor rack, tone, high security line supervision and 115 volt power supply	E4@12.0	Ea	8,890.00	616.00	9,506.00
Emergency power indicator for monitor panel	E4@1.14	Ea	284.00	58.50	342.50
Monitor panels					
Panel with accessory section, tone and standard line supervision	E4@.990	Ea	468.00	50.80	518.80
Panel with accessory section, tone and high security line supervision	E4@.904	Ea	705.00	46.40	751.40
Monitor racks					
1 zone with 115 volt power supply	E4@.904	Ea	387.00	46.40	433.40
10 zone with 115 volt power supply	E4@.904	Ea	1,980.00	46.40	2,026.40
10 zone with no power supply	E4@.904	Ea	1,550.00	46.40	1,596.40
Monitor cabinets					
1 zone monitor for wall mounted cabinet	E4@.990	Ea	606.00	50.80	656.80
5 zone monitor for wall mounted cabinet	E4@.990	Ea	775.00	50.80	825.80
10 zone monitor for wall mounted cabinet	E4@.990	Ea	946.00	50.80	996.80
20 zone monitor for wall mounted cabinet	E4@.990	Ea	1,290.00	50.80	1,340.80
50 zone monitor for wall mounted cabinet	E4@.990	Ea	2,870.00	50.80	2,920.80
50 zone monitor for floor mounted cabinet	E4@1.04	Ea	3,110.00	53.40	3,163.40
Balanced magnetic door switches					
Surface mounted	E4@2.02	Ea	118.00	104.00	222.00
Surface mounted with remote test	E4@2.02	Ea	166.00	104.00	270.00
Flush mounted	E4@2.02	Ea	114.00	104.00	218.00
Mounted bracket or spacer	E4@.249	Ea	6.85	12.80	19.65
Photoelectric sensors					
500' range, 12 volt DC	E4@2.02	Ea	324.00	104.00	428.00
800' range, 12 volt DC	E4@2.02	Ea	365.00	104.00	469.00
Fence type, 6 beam, without wire or trench	E4@3.89	Ea	11,800.00	200.00	12,000.00
Fence type, 9 beam, without wire or trench	E4@3.89	Ea	14,800.00	200.00	15,000.00
Capacitance wire grid systems					
Surface type	E4@.990	Ea	83.00	50.80	133.80
Duct type	E4@.990	Ea	67.70	50.80	118.50
Tube grid kit	E4@.990	Ea	124.00	50.80	174.80
Vibration sensors, to 30 per zone	E4@2.02	Ea	139.00	104.00	243.00
Audio sensors, to 30 per zone	E4@2.02	Ea	172.00	104.00	276.00
Inertia sensors, outdoor, without trenching	E4@2.02	Ea	114.00	104.00	218.00
Inertia sensors, indoor	E4@2.02	Ea	76.10	104.00	180.10
Electric sensor cable, 300 meters, no trenching	E4@3.89	Ea	1,730.00	200.00	1,930.00

27 Communications

	Craft@Hrs	Unit	Material	Labor	Total
Ultrasonic transmitters, to 20 per zone					
Omni-directional	E4@2.02	Ea	74.10	104.00	178.10
Directional	E4@2.02	Ea	82.90	104.00	186.90
Ultrasonic transceivers, to 20 per zone					
Omni-directional	E4@2.02	Ea	82.90	104.00	186.90
Directional	E4@2.02	Ea	88.90	104.00	192.90
High security	E4@2.02	Ea	302.00	104.00	406.00
Standard security	E4@2.02	Ea	125.00	104.00	229.00
Microwave perimeter sensor, to 4 per zone	E4@3.89	Ea	4,850.00	200.00	5,050.00
Passive interior infrared sensors, to 20 per zone					
Wide pattern	E4@2.02	Ea	673.00	104.00	777.00
Narrow pattern	E4@2.02	Ea	636.00	104.00	740.00
Access and secure control units					
For balanced magnetic door switches	E4@3.06	Ea	368.00	157.00	525.00
For photoelectric sensors	E4@3.06	Ea	673.00	157.00	830.00
For capacitance sensors	E4@3.06	Ea	682.00	157.00	839.00
For audio and vibration sensors	E4@3.06	Ea	787.00	157.00	944.00
For inertia sensors	E4@3.06	Ea	706.00	157.00	863.00
For nimmer (m.b.) detector	E4@3.06	Ea	586.00	157.00	743.00
For electric cable sensors	E4@3.06	Ea	3,550.00	157.00	3,707.00
For ultrasonic sensors	E4@3.06	Ea	1,070.00	157.00	1,227.00
For microwave sensors	E4@3.06	Ea	666.00	157.00	823.00
Accessories					
Tamper assembly for monitor cabinet	E4@.990	Ea	74.10	50.80	124.90
Monitor panel blank	E4@.249	Ea	8.27	12.80	21.07
Audible alarm	E4@.990	Ea	86.90	50.80	137.70
Audible alarm control	E4@.990	Ea	344.00	50.80	394.80
Termination screw terminal cabinet, 25 pair	E4@.990	Ea	249.00	50.80	299.80
Termination screw terminal cabinet, 50 pair	E4@1.36	Ea	405.00	69.80	474.80
Termination screw terminal cabinet, 150 pair	E4@3.45	Ea	659.00	177.00	836.00
Universal termination with remote test for cabinets and control panels	E4@1.47	Ea	60.90	75.50	136.40
Universal termination without remote test	E4@.990	Ea	35.70	50.80	86.50
High security line supervision termination					
With remote test and tone	E4@1.47	Ea	309.00	75.50	384.50
With tone only	E4@1.47	Ea	284.00	75.50	359.50
12" door cord for capacitance sensor	E4@.249	Ea	9.50	12.80	22.30
Insulation block kit for capacitance sensor	E4@.990	Ea	47.40	50.80	98.20
Termination block for capacitance sensor	E4@.249	Ea	10.10	12.80	22.90
200 zone graphic display	E4@3.06	Ea	4,740.00	157.00	4,897.00
210 zone multiplexer event recorder unit	E4@3.89	Ea	4,500.00	200.00	4,700.00
Guard alert display	E4@3.06	Ea	1,050.00	157.00	1,207.00
Uninterruptable power supply (battery)	E4@2.02	Ea	2,160.00	104.00	2,264.00
12 volt, 40VA plug-in transformer	E4@.495	Ea	40.80	25.40	66.20
18 volt, 40VA plug-in transformer	E4@.495	Ea	27.80	25.40	53.20
24 volt, 40VA plug-in transformer	E4@.495	Ea	20.20	25.40	45.60
Test relay	E4@.332	Ea	62.80	17.00	79.80
Sensor test control (average for sensors)	E4@.990	Ea	82.20	50.80	133.00
Cable, 2 pair 22 gauge, twisted, 1 pair shielded, run in exposed walls or per LF per pull, pulled in raceway and connected	E4@.008	LF	1.69	.41	2.10
Security access digital outdoor keypad/reader, modular single-unit type. Up to sixty users. Accepts cards, keyed-in passwords or both, non-volatile memory. Accepts any magnetic strip card format. Add the cost of the door actuator mechanism and the door. Cost includes control wiring.					
Digital access outdoor keypad/reader	CE@4.0	Ea	343.00	244.00	587.00

27 Communications

	Craft@Hrs	Unit	Material	Labor	Total
Fire Alarm and Detection Systems No wiring included except as noted.					
Pedestal mounted master fire alarm box	E4@3.89	Ea	1,470.00	200.00	1,670.00
Automatic coded signal transmitter	E4@3.89	Ea	769.00	200.00	969.00
Fire alarm control panel, simplex	E4@3.89	Ea	722.00	200.00	922.00
Fire detection annunciator panel					
8 zone drop	E4@3.89	Ea	478.00	200.00	678.00
12 zone drop	E4@5.03	Ea	628.00	258.00	886.00
16 zone drop	E4@5.93	Ea	974.00	304.00	1,278.00
8 zone lamp panel only	E4@4.33	Ea	159.00	222.00	381.00
12 zone lamp panel only	E4@5.93	Ea	233.00	304.00	537.00
16 zone lamp panel only	E4@7.23	Ea	310.00	371.00	681.00
Battery charger and cabinet, simplex	E4@6.19	Ea	415.00	318.00	733.00
Add for nickel cadmium batteries	E4@3.89	Ea	450.00	200.00	650.00
Fire alarm pull stations, manual operation	E4@.497	Ea	23.30	25.50	48.80
Fire alarm 10" bell with outlet box	E4@.497	Ea	75.80	25.50	101.30
Magnetic door holder	E4@1.33	Ea	71.20	68.30	139.50
Combination door holder and closer	E4@2.48	Ea	289.00	127.00	416.00
Detex door lock	E4@2.72	Ea	34.20	140.00	174.20
Thermodetector	E4@.497	Ea	10.20	25.50	35.70
Ionization AC smoke detector, with wiring	E4@.710	Ea	176.00	36.50	212.50
Fixed temp. and rate of rise smoke detector	E4@.746	Ea	15.90	38.30	54.20
Carbon dioxide pressure switch	E4@.746	Ea	5.43	38.30	43.73
Telephone Wiring					
Plywood backboard mount for circuit wiring, set on masonry wall					
4' x 4' x 3/4"	E4@.938	Ea	24.40	48.20	72.60
4' x 8' x 3/4"	E4@1.10	Ea	48.90	56.50	105.40
Cable tap in a manhole or junction box					
25 to 50 pair cable	E4@7.80	Ea	152.00	400.00	552.00
100 to 200 pair cable	E4@10.1	Ea	177.00	519.00	696.00
300 pair cable	E4@12.0	Ea	178.00	616.00	794.00
400 pair cable	E4@13.0	Ea	192.00	667.00	859.00
Cable terminations in a manhole or junction box					
25 pair cable	E4@1.36	Ea	13.70	69.80	83.50
50 pair cable	E4@1.36	Ea	15.80	69.80	85.60
100 pair cable	E4@2.72	Ea	31.60	140.00	171.60
150 pair cable	E4@3.45	Ea	47.80	177.00	224.80
200 pair cable	E4@4.61	Ea	71.60	237.00	308.60
300 pair cable	E4@5.03	Ea	95.10	258.00	353.10
400 pair cable	E4@5.34	Ea	126.00	274.00	400.00
Communications cable, pulled in conduit or walls and connected					
2 pair cable	E4@.008	LF	.16	.41	.57
25 pair cable	E4@.030	LF	1.89	1.54	3.43
50 pair cable	E4@.043	LF	4.03	2.21	6.24
75 pair cable	E4@.043	LF	5.01	2.21	7.22
100 pair cable	E4@.043	LF	5.84	2.21	8.05
150 pair cable	E4@.045	LF	8.13	2.31	10.44
200 pair cable	E4@.051	LF	10.60	2.62	13.22
300 pair cable	E4@.051	LF	15.70	2.62	18.32
Telephone outlets (no junction box included)					
Wall outlet	E4@.396	Ea	8.30	20.30	28.60
Floor outlet, flush mounted	E4@.495	Ea	10.30	25.40	35.70

27 Communications

	Craft@Hrs	Unit	Material	Labor	Total
Closed Circuit Television Systems					
Outdoor television camera in weatherproof housing, cable preinstalled.					
Wall or roof mount, professional grade	E4@.500	Ea	1,570.00	25.70	1,595.70
Wall or roof mount, economy	E4@.500	Ea	220.00	25.70	245.70
Self-terminating outlet box, cover plate	E4@.245	Ea	4.94	12.60	17.54
Coaxial cable (RG59/J), 75 ohms, no raceway included	E4@.006	LF	.36	.31	.67
In-line cable taps (PTU) for 36" TV system	E4@.689	Ea	7.19	35.40	42.59
Cable blocks for in-line taps	—	Ea	3.71	—	3.71
Desk-type TV monitor, 19" diagonal screen, 75 ohms, labor includes hookup only					
4 camera inputs	E4@.500	Ea	337.00	25.70	362.70
Security CCTV digital video recorder central control station, modular single-unit type. Allows up to 16 discrete channels and simultaneous real-time monitoring of all 16 channels. Digital video recorder saves pictures every 3 seconds per channel. Password control access to DVD data only. Cost includes monitor, PC, software, cable connectors for sixteen stations, keyboard, mouse, software training and installation. Add the cost of wiring to digital CCTV's.					
Security CCTV recorder control station	CE@4.0	Ea	5,500.00	244.00	5,744.00
Public Address Paging Systems					
Signal cable, #22 solid copper polyethylene insulated, PVC jacketed wire					
Pulled in conduit, no conduit included	E4@.008	LF	.16	.41	.57
Microphone, desk type, push to talk, with					
7' of three conductor cable	E4@.250	Ea	114.00	12.80	126.80
Wall mounted enameled steel amplifier cabinet (18" high, 24" wide, 6" deep) with electrical receptacle and lockable door					
	E4@1.67	Ea	350.00	85.70	435.70
Amplifier, 100 watts, 4 inputs, installation includes hookup only, no wire pull					
Complete unit	E4@.500	Ea	376.00	25.70	401.70
Wall mounted paging horns, transformer type, 250 to 13,000 Hertz, 8 ohms, 30 Watts, 10" diameter, 12" deep, gray baked enamel, labor includes hookup only					
Interior/exterior 15/30 Watts	E4@.250	Ea	70.80	12.80	83.60
Ceiling mounted 8" speaker with 12" grill, labor includes installation and hookup only, no wire pull					
8" ceiling speaker	E4@.330	Ea	30.40	16.90	47.30
8" ceiling speaker with volume	E4@.330	Ea	32.80	16.90	49.70
Outdoor weather resistant speakers					
Landscape weather resistant	E4@.330	Ea	239.00	16.90	255.90
Rock landscape (high end)	E4@.330	Ea	473.00	16.90	489.90
Computer Network Cable Pulled in conduit or walls. Add for connectors and cable testing. Prices are for cable purchased in bulk on 1,000' spools.					
Coaxial cable					
Thin Ethernet, 50 ohm, 10BASE2 (RG58). Used in modern networks for Wireless Network high gain antennae					
PVC cable	E4@.008	LF	.16	.41	.57
Plenum cable	E4@.008	LF	.42	.41	.83
Fiber optic cable					
Singlemode fiber optic cable, duplex is 4 strand, simplex is 1 strand					
Singlemode duplex fiber optic cables (8.3/125)	E4@.012	LF	.25	.62	.87
Singlemode simplex fiber optic cables (8.3/125)	E4@.012	LF	.24	.62	.86
Multimode fiber optic cable, duplex is a zip type					
Multimode duplex fiber optic cables (50/125)	E4@.012	LF	.28	.62	.90
Multimode duplex fiber optic cables (62.5/125)	E4@.012	LF	.28	.62	.90
Multimode simplex fiber optic cables (50/125)	E4@.012	LF	.28	.62	.90
Multimode simplex fiber optic cables (62.5/125)	E4@.012	LF	.28	.62	.90

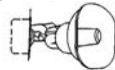

27 Communications

	Craft@Hrs	Unit	Material	Labor	Total
Twisted pair Category 5, 100 Mbps, material price based on purchase of 1000' rolls. Use solid cable for horizontal runs. STP is shielded					
4 pair UTP PVC stranded cable	E4@.008	LF	.14	.41	.55
4 pair UTP PVC solid cable	E4@.008	LF	.14	.41	.55
4 pair UTP plenum solid cable	E4@.008	LF	.27	.41	.68
4 pair STP PVC stranded cable	E4@.008	LF	.24	.41	.65
4 pair STP PVC solid cable	E4@.008	LF	.24	.41	.65
4 pair STP plenum solid cable	E4@.008	LF	.27	.41	.68
Twisted pair Category 5e, 350 Mbps, material price based on purchase of 1,000' rolls, use solid for horizontal runs. STP is shielded.					
4 pair UTP PVC solid	E4@.008	LF	.23	.41	.64
4 pair UTP PVC stranded	E4@.008	LF	.23	.41	.64
4 pair UTP plenum solid	E4@.008	LF	.33	.41	.74
4 pair STP PVC stranded	E4@.008	LF	.24	.41	.65
4 pair STP PVC solid	E4@.008	LF	.24	.41	.65
4 pair STP plenum solid	E4@.008	LF	.34	.41	.75
Twisted pair Category 6, 1 Gbps, material price based on purchase of 1,000' rolls, use solid for horizontal runs					
4 pair UTP PVC stranded	E4@.008	LF	.24	.41	.65
4 pair UTP PVC solid	E4@.008	LF	.25	.41	.66
4 pair UTP plenum solid	E4@.008	LF	.39	.41	.80
Add for multiple cable pulls of thin Ethernet or unshielded twisted pair cables when cables are pulled simultaneously in plenum or PVC, based on quantity of cables pulled					
Add for each cable pulled simultaneously, over one	E4@.250	Ea	—	12.80	12.80
Punch-down blocks					
Plywood backboard mount for patch panel or punch-down blocks, set on a masonry wall					
4' x 4' x 3/4"	E4@.938	Ea	24.40	48.20	72.60
4' x 8' x 3/4"	E4@1.10	Ea	48.90	56.50	105.40
Distribution frame for punch-down blocks					
Holds 5 punch-down blocks	E4@.250	Ea	33.80	12.80	46.60
Holds 10 punch-down blocks	E4@.250	Ea	40.20	12.80	53.00
Punch-down blocks, labor is to install block in distribution frame only, add labor to punch-down wire pairs as shown below					
50 pair	E4@.250	Ea	18.30	12.80	31.10
100 pair	E4@.250	Ea	26.60	12.80	39.40
Punch-down wire pairs, labor only, per pair	E4@.020	Ea	—	1.03	1.03
Computer network cable connectors					
Coax					
Thin Ethernet					
BNC type, crimp on, female	E4@.100	Ea	4.90	5.13	10.03
Fiber optic cable, terminated, 10' length					
ST-ST singlemode duplex riser	E4@.100	Ea	74.80	5.13	79.93
ST-SC singlemode duplex riser	E4@.100	Ea	74.80	5.13	79.93
SC-SC singlemode duplex riser	E4@.100	Ea	74.80	5.13	79.93
FC-SC singlemode duplex riser	E4@.100	Ea	74.80	5.13	79.93
ST-ST singlemode simplex riser	E4@.100	Ea	41.00	5.13	46.13
ST-SC singlemode simplex riser	E4@.100	Ea	41.00	5.13	46.13
SC-SC singlemode simplex riser	E4@.100	Ea	41.00	5.13	46.13
FC-SC singlemode simplex riser	E4@.100	Ea	41.00	5.13	46.13
ST-ST multimode duplex riser	E4@.100	Ea	34.00	5.13	39.13

27 Communications

	Craft@Hrs	Unit	Material	Labor	Total
ST-SC multimode duplex riser	E4@.100	Ea	34.00	5.13	39.13
SC-SC multimode duplex riser	E4@.100	Ea	34.00	5.13	39.13
FC-SC multimode duplex riser	E4@.100	Ea	102.00	5.13	107.13
FDDI-FDDI multimode duplex riser	E4@.100	Ea	129.00	5.13	134.13
FDDI OFNP plenum	E4@.100	Ea	122.00	5.13	127.13
Fiber optic cable connectors, special tools required					
SC multimode connector	E4@.150	Ea	10.90	7.70	18.60
SC singlemode connector	E4@.150	Ea	12.20	7.70	19.90
FC multimode connector	E4@.150	Ea	12.20	7.70	19.90
FC singlemode connector	E4@.150	Ea	12.20	7.70	19.90
ST multimode connector	E4@.150	Ea	10.90	7.70	18.60
ST singlemode connector	E4@.150	Ea	12.20	7.70	19.90
FDDI for round cable	E4@.150	Ea	20.60	7.70	28.30
FDDI for Zip cable	E4@.150	Ea	20.60	7.70	28.30
Shielded twisted pair (STP)					
IBM Type 2, 6 pair data connector	E4@.100	Ea	2.87	5.13	8.00
IBM Type 6, 2 pair data connector	E4@.150	Ea	4.01	7.70	11.71
IBM Type 9, 2 pair data connector	E4@.150	Ea	4.01	7.70	11.71
Twisted pair connectors (UTP) and (STP), modular hand tool required, material prices based on package of 50					
RJ11	E4@.100	Ea	.71	5.13	5.84
Cat5-rated RJ45 connectors for solid wire	E4@.100	Ea	.98	5.13	6.11
Cat5-rated RJ45 connectors for stranded wire	E4@.100	Ea	.98	5.13	6.11
Cat6-rated RJ45 connectors for stranded wire	E4@.100	Ea	.98	5.13	6.11
Shielded RJ45 connectors for solid or stranded wire	E4@.100	Ea	2.77	5.13	7.90
Cable testing , with dedicated cable tester					
Coax cable, per conductor	E4@.125	Ea	—	6.42	6.42
Fiber optic cable, per segment	E4@.160	Ea	—	8.21	8.21
Shielded twisted pair (STP), per pair	E4@.125	Ea	—	6.42	6.42
Unshielded twisted pair (UTP), per pair	E4@.125	Ea	—	6.42	6.42
Wall plates					
Coax wall plates with jacks (no junction box included)					
One or two jacks, including termination	E4@.396	Ea	.59	20.30	20.89
Modular wall plates with jacks for UTP (no junction box included), including termination					
One 4 or 6 wire jack (RJ11)	E4@.396	Ea	2.93	20.30	23.23
One 8 wire jack (RJ45)	E4@.396	Ea	2.93	20.30	23.23
Two 8 wire jacks (RJ45)	E4@.450	Ea	4.09	23.10	27.19

31 Earthwork

	Craft@Hrs	Unit	Material	Labor	Equipment	Total
--	-----------	------	----------	-------	-----------	-------

Site Clearing Using a dozer as described below, a 3/4 CY wheel loader and two 10 CY dump trucks. Clearing costs will be higher on smaller jobs and where the terrain limits production. These costs include hauling 6 miles to a legal dump. Dump fees are not included. See Waste Disposal. Figures in parentheses show the approximate "loose" volume of the material to be loaded and hauled to the dump. For estimating purposes, assume that the cost of moving equipment on and off the job site will be equal to the cost of clearing one acre. For more detailed coverage, see *National Earthwork and Heavy Equipment Estimator* at <https://craftsman-book.com/national-estimator-cloud>.

Clear light brush and grub roots

Using a 105 HP D-5 dozer (350 CY)	C2@34.8	Acre	—	1,740.00	2,350.00	4,090.00
-----------------------------------	---------	------	---	----------	----------	----------

31 Earthwork

	Craft@Hrs	Unit	Material	Labor	Equipment	Total
Clear medium brush and small trees, grub roots Using a 130 HP D-6 dozer (420 CY)	C2@41.8	Acre	—	2,100.00	2,600.00	4,700.00
Clear brush and trees to 6" trunk diameter Using a 335 HP D-8 dozer (455 CY)	C2@45.2	Acre	—	2,270.00	2,930.00	5,200.00
Clear wooded area, pull stumps Using a 460 HP D-9 dozer (490 CY)	C2@48.7	Acre	—	2,440.00	4,830.00	7,270.00
Strip, stockpile on site and then replace topsoil Using a 100 HP D-4 tractor	S1@.069	CY	—	3.40	6.93	10.25

Building Layout Typical cost for a survey crew to lay out site improvements for a 100,000 SF single-story commercial building and associated walks, drainage and parking. Includes preparation of a project control map, setting benchmarks, marking site disturbance limits at 50' intervals, aligning roadways and parking areas and setting lath or stakes as required for rough grading. Based on ten visits to the site by the survey crew.

Initial boundary control survey	—	LS	—	—	—	1,040.00
Site rough grading, set lath	—	LS	—	—	—	1,500.00
Sanitary sewer, alignment and grade	—	LS	—	—	—	720.00
Storm drainage, alignment and grade	—	LS	—	—	—	2,250.00
Water main, hydrants, alignment and grade	—	LS	—	—	—	2,250.00
Curb, set stakes at 25' stations (3 visits)	—	LS	—	—	—	4,170.00
Building corners, location and grade	—	LS	—	—	—	1,150.00
Run-off detention pond, position and grade	—	LS	—	—	—	900.00
Retaining walls, alignment and grade	—	LS	—	—	—	1,050.00
Walkways, alignment and grade	—	LS	—	—	—	1,020.00
Light pole bases, location and grade	—	LS	—	—	—	750.00
Building I.D. sign, location and grade	—	LS	—	—	—	350.00

Rock Excavation Rock drilling costs. Based on using a pneumatic truck-mounted wagon drill. Equipment includes one wheel-mounted air compressor and one 4-1/2" pneumatic wagon drill with hydraulic swing boom and drill bits. Costs shown are per linear foot of hole drilled. Add blasting costs below. Use \$2,500 as a minimum job charge.

LF per hour shown is for a 2-man crew.

Easy work, 38 LF per hour	S1@.052	LF	—	2.59	3.44	6.03
Moderate work, 30 LF per hour	S1@.067	LF	—	3.33	4.43	7.76
Most work, 25 LF per hour	S1@.080	LF	—	3.98	5.29	9.27
Hard work, 20 LF per hour	S1@.100	LF	—	4.97	6.62	11.59
Dense rock, 15 LF per hour	S1@.132	LF	—	6.56	8.73	15.29
Drilling 2-1/2" hole for rock bolts, 24 LF/hour	S1@.086	LF	—	4.28	5.69	9.97

Blasting costs Based on two cycles per hour and 20 linear foot lifts. These costs assume 75% fill of holes with explosives. Equipment includes one flatbed truck. Costs shown are per cubic yard of area blasted. Loading or hauling of blasted material not included. Use \$3,500 as a minimum job charge. Load explosives in holes and detonate, by pattern spacing. CY per hour shown is for a 5-man crew.

Using explosives, per pound	—	Lb	5.93	—	—	5.93
6' x 6' pattern (26 CY per hour)	C1@.192	CY	17.80	8.19	.86	26.85
7' x 7' pattern (35 CY per hour)	C1@.144	CY	13.30	6.14	.65	20.09
7' x 8' pattern (47 CY per hour)	C1@.106	CY	10.30	4.52	.48	15.30
9' x 9' pattern (60 CY per hour)	C1@.084	CY	8.88	3.58	.36	12.82
10' x 10' pattern (72 CY per hour)	C1@.069	CY	7.40	2.94	.38	10.72
12' x 12' pattern (108 CY per hour)	C1@.046	CY	5.04	1.96	.21	7.21
14' x 14' pattern (147 CY per hour)	C1@.034	CY	3.55	1.45	.15	5.15

31 Earthwork

	Craft@Hrs	Unit	Material	Labor	Equipment	Total
Site Grading Layout, staking, flagmen, lights, watering, ripping, rock breaking, loading or hauling not included. Site preparation grading based on using one crawler tractor. Use \$3,000.00 as a minimum job charge. (One acre is 43,560 SF or 4,840 SY.)						
General area rough grading with 100 HP D-4 tractor (.5 acres per hour)	S1@4.00	Acre	—	199.00	141.00	340.00
General area rough grading with 335 HP D-8 tractor (1 acre per hour)	S1@2.00	Acre	—	99.50	187.00	286.50
Site grading based on using one 100 HP (10,000 lb) motor grader						
General area grading (.7 acres per hour)	S1@2.86	Acre	—	142.00	108.00	250.00
Fine grading subgrade to 1/10' (.45 acres per hour)	S1@4.44	Acre	—	221.00	169.00	390.00
Cut slope or shape embankment to 2' high (.25 acres per hour)	S1@8.00	Acre	—	398.00	304.00	702.00
Rough grade sub-base course on roadway (.2 acres per hour)	S1@10.0	Acre	—	497.00	381.00	878.00
Finish grade base or leveling course on roadway (.17 acres per hour)	S1@11.8	Acre	—	587.00	450.00	1,037.00
Finish grading for building slab, windrow excess (1,000 SF per hour)	S1@.002	SF	—	.10	.08	.18
Ripping rock Based on using a tractor-mounted ripper. Equipment includes a D-8 dozer and a D-9 dozer. Costs shown are per CY of area ripped. Loading or hauling of material not included. Use \$2,000 as a minimum job charge.						
Clay or glacial tills, D-9 cat tractor with 2-shank ripper (500 CY per hour)	T0@.002	CY	—	.12	.60	.72
Clay or glacial tills, D-8 cat tractor with 1-shank ripper (335 CY per hour)	T0@.003	CY	—	.17	.56	.73
Shale, sandstone, or limestone, D-9 cat tractor with 2-shank ripper (125 CY per hour)	T0@.008	CY	—	.46	2.40	2.86
Shale, sandstone, or limestone, D-8 cat tractor with 1-shank ripper (95 CY per hour)	T0@.011	CY	—	.64	2.06	2.70
Slate, metamorphic rock, D-9 cat tractor with 2-shank ripper (95 CY per hour)	T0@.011	CY	—	.64	3.30	3.94
Slate, metamorphic rock, D-8 cat tractor with 1-shank ripper (63 CY per hour)	T0@.016	CY	—	.92	3.00	3.92
Granite or basalt, D-9 cat tractor with 2-shank ripper (78 CY per hour)	T0@.013	CY	—	.75	3.90	4.65
Granite or basalt, D-8 cat tractor with 1-shank ripper (38 CY per hour)	T0@.027	CY	—	1.56	5.06	6.62
Rock loosening Based on using pneumatic jackhammers. Equipment includes one compressor and two jackhammers with chisel points. Costs shown are per CY of area loosened. Loading and hauling not included. CY per hour shown is for a 2-man crew. Use \$800 as a minimum job charge.						
Igneous or dense rock (1.4 CY per hour)	CL@1.43	CY	—	59.60	55.90	115.50
Most weathered rock (2.4 CY per hour)	CL@.835	CY	—	34.80	32.70	67.50
Soft sedimentary rock (4 CY per hour)	CL@.500	CY	—	20.80	19.60	40.40

31 Earthwork

	Craft@Hrs	Unit	Material	Labor	Equipment	Total
Embankment Grading Earth embankment spreading, shaping, compacting and watering, and finish shaping. Use \$15,000 as a minimum job charge, loading or hauling of earth fill not included.						
Spreading and shaping. Spread and shape earth from loose piles, based on using a D-8 tractor.						
6" to 10" lifts (164 CY per hour)	T0@.006	CY	—	.35	1.11	1.46
Compacting and watering. (Add for cost of water from below.) CY per hour shown is for a 3-man crew. Based on using a self-propelled 100 HP vibrating roller and a 3,500 gallon truck. Productivity assumes 3 passes at 7' wide.						
6" lifts (500 CY per hour)	C3@.006	CY	—	.29	.30	.59
Compacting with a sheepsfoot roller towed behind a D-7 tractor and a 3,500 gallon truck. Productivity assumes 3 passes at 5' wide						
6" lifts (185 CY per hour)	C3@.016	CY	—	.78	1.34	2.12
8" lifts (245 CY per hour)	C3@.012	CY	—	.58	1.01	1.59
Cost of water for compacted earth embankments. Based on water at \$3.25 per 1,000 gallons and 66 gallons per cubic yard of compacted material. Assumes optimum moisture at 10%, natural moisture of 2% and evaporation of 2%. Placed in conjunction with compaction shown above.						
Cost per CY of compacted embankment	—	CY	.33	—	—	.33
Finish shaping of embankments. Earth embankment slopes and swales up to 1 in 4 incline. Based on using a 150 HP grader and a 15-ton self-propelled rubber tired roller. SY per hour shown is for a 3-man crew. (200 SY per hour)						
(200 SY per hour)	SS@.016	SY	—	.82	1.14	1.96
Finish shaping of embankments with a D-8 tractor						
(150 SY per hour)	T0@.007	SY	—	.40	1.31	1.71
Finish shaping of embankment slopes and swales by hand. SY per hour shown is for 1 man.						
Slopes up to 1 in 4 (16 SY per hour)	CL@.063	SY	—	2.62	—	2.62
Slopes over 1 in 4 (12.5 SY per hour)	CL@.080	SY	—	3.33	—	3.33
Trench Excavation and Backfill (200 SY per hour) These costs and productivity are based on utility line trenches and continuous footings where the spoil is piled adjacent to the trench. Linear feet (LF), cubic yards (CY), square feet (SF), or square yards (SY) per hour shown are based on a 2-man crew. Increase costs by 10% to 25% when spoil is loaded in trucks. Hauling, shoring, dewatering or unusual conditions are not included.						
12" wide bucket, for 12" wide trench. Depths 3' to 5'. Equipment is a wheel loader with 1 CY bucket and integral backhoe. Use \$400 as a minimum job charge.						
Light soil (60 LF per hour)	S1@.033	LF	—	1.64	.56	2.20
Medium soil (55 LF per hour)	S1@.036	LF	—	1.79	.61	2.40
Heavy or wet soil (35 LF per hour)	S1@.057	LF	—	2.83	.96	3.79
18" wide bucket, for 18" wide trench. Depths 3' to 5'. Equipment is a wheel loader with 1 CY bucket and integral backhoe. Use \$400 as a minimum job charge.						
Light soil (55 LF per hour)	S1@.036	LF	—	1.79	.61	2.40
Medium soil (50 LF per hour)	S1@.040	LF	—	1.99	.67	2.66
Heavy or wet soil (30 LF per hour)	S1@.067	LF	—	3.33	1.13	4.46
24" wide bucket, for 24" wide trench. Depths 3' to 5'. Equipment is a wheel loader with 1 CY bucket and integral backhoe. Use \$400 as a minimum job charge.						
Light soil (50 LF per hour)	S1@.040	LF	—	1.99	.67	2.66
Medium soil (45 LF per hour)	S1@.044	LF	—	2.19	.74	2.93
Heavy or wet soil (25 LF per hour)	S1@.080	LF	—	3.98	1.35	5.33
Truck-mounted Gradall with 1 CY bucket. Use \$700 as a minimum job charge.						
Light soil (40 CY per hour)	S1@.050	CY	—	2.49	4.24	6.73
Medium soil (34 CY per hour)	S1@.059	CY	—	2.93	5.01	7.94
Heavy or wet soil (27 CY per hour)	S1@.074	CY	—	3.68	6.28	9.96
Loose rock (23 CY per hour)	S1@.087	CY	—	4.33	7.39	11.72
Crawler-mounted hydraulic backhoe with 3/4 CY bucket. Use \$500 as a minimum job charge.						
Light soil (33 CY per hour)	S1@.061	CY	—	3.03	3.09	6.12
Medium soil (27 CY per hour)	S1@.074	CY	—	3.68	3.75	7.43
Heavy or wet soil (22 CY per hour)	S1@.091	CY	—	4.53	4.61	9.14
Loose rock (18 CY per hour)	S1@.112	CY	—	5.57	5.67	11.24

31 Earthwork

	Craft@Hrs	Unit	Material	Labor	Equipment	Total
Crawler-mounted hydraulic backhoe with 1 CY bucket. Use \$500 as a minimum job charge.						
Light soil (65 CY per hour)	S1@.031	CY	—	1.54	1.26	2.80
Medium soil (53 CY per hour)	S1@.038	CY	—	1.89	1.54	3.43
Heavy or wet soil (43 CY per hour)	S1@.047	CY	—	2.34	1.90	4.24
Loose rock (37 CY per hour)	S1@.055	CY	—	2.74	2.23	4.97
Blasted rock (34 CY per hour)	S1@.058	CY	—	2.88	2.35	5.23
Crawler-mounted hydraulic backhoe with 1-1/2 CY bucket. Use \$500 as a minimum job charge.						
Light soil (83 CY per hour)	S1@.024	CY	—	1.19	1.04	2.23
Medium soil (70 CY per hour)	S1@.029	CY	—	1.44	1.24	2.68
Heavy or wet soil (57 CY per hour)	S1@.035	CY	—	1.74	1.54	3.28
Loose rock (48 CY per hour)	S1@.042	CY	—	2.09	1.79	3.88
Blasted rock (43 CY per hour)	S1@.047	CY	—	2.34	1.99	4.33
Crawler-mounted hydraulic backhoe with 2 CY bucket. Use \$700 as a minimum job charge.						
Light soil (97 CY per hour)	S1@.021	CY	—	1.04	1.04	2.08
Heavy or wet soil (65 CY per hour)	S1@.031	CY	—	1.54	1.54	3.08
Loose rock (55 CY per hour)	S1@.036	CY	—	1.79	1.79	3.58
Blasted rock (50 CY per hour)	S1@.040	CY	—	1.99	1.99	3.98
Crawler-mounted hydraulic backhoe with 2-1/2 CY bucket. Use \$750 as a minimum job charge.						
Light soil (122 CY per hour)	S1@.016	CY	—	.80	1.25	2.05
Medium soil (100 CY per hour)	S1@.020	CY	—	.99	1.56	2.55
Heavy or wet soil (82 CY per hour)	S1@.024	CY	—	1.19	1.87	3.06
Loose rock (68 CY per hour)	S1@.029	CY	—	1.44	2.26	3.70
Blasted rock (62 CY per hour)	S1@.032	CY	—	1.59	2.50	4.09
Chain-boom Ditch Witch digging trench to 12" wide and 5' deep. Use \$400 as a minimum job charge.						
Light soil (10 CY per hour)	S1@.200	CY	—	9.95	3.21	13.16
Most soils (8.5 CY per hour)	S1@.235	CY	—	11.70	3.77	15.47
Heavy soil (7 CY per hour)	S1@.286	CY	—	14.20	4.59	18.79
Trenchers, chain boom, 55 HP, digging trench to 18" wide and 8' deep. Use \$500 as a minimum job charge.						
Light soil (62 CY per hour)	S1@.032	CY	—	1.59	.71	2.30
Most soils (49 CY per hour)	S1@.041	CY	—	2.04	.91	2.95
Heavy soil (40 CY per hour)	S1@.050	CY	—	2.49	1.11	3.60
Trenchers, chain boom, 100 HP, digging trench to 24" wide and 8' deep. Use \$500 as a minimum job charge.						
Light soil (155 CY per hour)	S1@.013	CY	—	.65	.94	1.59
Most soils (125 CY per hour)	S1@.016	CY	—	.80	1.15	1.95
Heavy soil (100 CY per hour)	S1@.020	CY	—	.99	1.44	2.43
Trim trench bottom to 1/10'						
By hand (200 SF per hour)	CL@.010	SF	—	.42	—	.42
Backfill trenches from loose material piled adjacent to a trench. No compaction included. Soil previously excavated. (200 SY per hour)						
Backfill trenches by hand						
(8 CY per hour)	CL@.250	CY	—	10.40	—	10.40
Wheel loader 55 HP. Use \$400 as a minimum job charge						
Typical soils (50 CY per hour)	S1@.040	CY	—	1.99	.70	2.69
D-3 crawler dozer. Use \$475 as a minimum job charge						
Typical soils (25 CY per hour)	S1@.080	CY	—	3.98	2.22	6.20
3/4 CY crawler loader. Use \$450 as a minimum job charge						
Typical soils (33 CY per hr)	S1@.061	CY	—	3.03	1.37	4.40
D-7 crawler dozer. Use \$700 as a minimum job charge						
Typical soils (130 CY per hour)	S1@.015	CY	—	.75	.92	1.67

31 Earthwork

	Craft@Hrs	Unit	Material	Labor	Equipment	Total
Wheel loader 55 HP. Sand or gravel bedding. Use \$400 as a minimum job charge						
Typical soils (80 CY per hour)	S1@.025	CY	—	1.24	.44	1.68
Fine grade bedding by hand						
(22 SY per hr)	CL@.090	SY	—	3.75	—	3.75
Compaction of soil in trenches in 8" layers. Use \$200 as a minimum job charge						
Pneumatic tampers						
(20 CY per hour)	CL@.050	CY	—	2.08	1.82	3.90
Vibrating rammers						
(10 CY per hour)	CL@.100	CY	—	4.17	1.31	5.48

Dragline Excavation For mass excavation, footings or foundations. Costs shown include casting the excavated soil adjacent to the excavation or loading it into trucks. Hauling costs are not included. Cubic yards (CY) per hour are as measured in an undisturbed condition (bank measure) and are based on a 2-man crew. Use \$3,000 as a minimum job charge.

1-1/2 CY dragline with a 45-ton crawler crane						
Loam or light clay (73 CY per hour)	H2@.027	CY	—	1.41	1.62	3.03
Sand or gravel (67 CY per hour)	H2@.030	CY	—	1.57	1.80	3.37
Heavy clay (37 CY per hour)	H2@.054	CY	—	2.83	3.23	6.06
Unclassified soil (28 CY per hour)	H2@.071	CY	—	3.72	4.25	7.97
2 CY dragline with a 60-ton crawler crane						
Loam or light clay (88 CY per hour)	H2@.023	CY	—	1.20	1.94	3.14
Sand or gravel (85 CY per hour)	H2@.024	CY	—	1.26	2.03	3.29
Heavy clay (48 CY per hour)	H2@.042	CY	—	2.20	3.55	5.75
Unclassified soil (36 CY per hour)	H2@.056	CY	—	2.93	4.73	7.66
2-1/2 CY dragline with a 100-ton crawler crane						
Loam or light clay (102 CY per hour)	H2@.019	CY	—	.99	1.83	2.82
Sand or gravel (98 CY per hour)	H2@.021	CY	—	1.10	2.02	3.12
Heavy clay (58 CY per hour)	H2@.035	CY	—	1.83	3.37	5.20
Unclassified soil (44 CY per hour)	H2@.045	CY	—	2.36	4.33	6.69
3 CY dragline with a 150-ton crawler crane						
Loam or light clay (116 CY per hour)	H2@.017	CY	—	.89	2.31	3.20
Sand or gravel (113 CY per hour)	H2@.018	CY	—	.94	2.44	3.38
Heavy clay (70 CY per hour)	H2@.029	CY	—	1.52	3.94	5.46
Unclassified soil (53 CY per hour)	H2@.038	CY	—	1.99	5.16	7.15

Backhoe Excavation For mass excavation, footing or foundation costs shown include casting the excavated soil adjacent to the excavation or loading it into trucks. Hauling costs are not included. Cubic yards (CY) per hour are as measured in an undisturbed condition (bank measure) and are based on a 2-man crew. Equipment costs are based on using a crawler-mounted hydraulic backhoe. Use \$2,500 as a minimum job charge

1 CY backhoe						
Light soil (69 CY per hour)	S1@.029	CY	—	1.44	.83	2.27
Most soils (57 CY per hour)	S1@.035	CY	—	1.74	1.00	2.74
Wet soil, loose rock (46 CY per hour)	S1@.043	CY	—	2.14	1.23	3.37
1-1/2 CY backhoe						
Light soil (90 CY per hour)	S1@.022	CY	—	1.09	.62	1.71
Most soils (77 CY per hour)	S1@.026	CY	—	1.29	.73	2.02
Wet soil, loose rock (60 CY per hour)	S1@.033	CY	—	1.64	.93	2.57
Blasted rock (54 CY per hour)	S1@.044	CY	—	2.19	1.24	3.43
2 CY backhoe						
Light soil (100 CY per hour)	S1@.020	CY	—	.99	.96	1.95
Most soils (85 CY per hour)	S1@.023	CY	—	1.14	1.11	2.25
Wet soil, loose rock (70 CY per hour)	S1@.029	CY	—	1.44	1.39	2.83

31 Earthwork

	Craft@Hrs	Unit	Material	Labor	Equipment	Total
Moving and Loading Excavated Materials Costs shown include moving the material 50' and dumping it into piles or loading it into trucks. Add 25% for each 50' of travel beyond the first 50'. Hauling costs are not included. Cubic yards (CY) per hour are for material in a loose condition (previously excavated) and are based on a 2-man crew performing the work. Equipment costs are based on using a wheel-mounted front-end loader. Use \$2,000 as a minimum job charge.						
3/4 CY loader (32 CY per hour)	S1@.062	CY	—	3.08	1.01	4.09
1 CY loader (55 CY per hour)	S1@.036	CY	—	1.79	.77	2.56
2 CY loader (90 CY per hour)	S1@.022	CY	—	1.09	.65	1.74
3-1/4 CY loader (125 CY per hour)	S1@.016	CY	—	.80	.66	1.46
5 CY loader (218 CY per hour)	S1@.009	CY	—	.45	.43	.88
Hauling excavated material Using trucks. Costs shown include 4 minutes for loading, 3 minutes for dumping and travel time based on the one-way distance, speed and cycles per hour as noted. Costs for equipment to excavate and load the material are not included. Truck capacity is based on cubic yards of loose material. Use the following percentages to calculate swell (from bank measure) and shrinkage (when dumped at the fill site): clay (33%), common earth (25%), granite (65%), mud (21%), sand or gravel (12%).						
3 CY dump truck. Use \$550 as a minimum job charge.						
1 mile haul at 20 MPH (4.62 cycles and 13.85 CY per hour)	TD@.072	CY	—	3.36	3.20	6.56
3 mile haul at 30 MPH (3.16 cycles and 9.47 CY per hour)	TD@.106	CY	—	4.95	4.71	9.66
6 mile haul at 40 MPH (2.4 cycles and 7.2 CY per hour)	TD@.139	CY	—	6.49	6.17	12.66
5 CY dump truck. Use \$600 as a minimum job charge.						
1 mile haul at 20 MPH (4.62 cycles and 23.08 CY per hour)	TD@.043	CY	—	2.01	1.99	4.00
3 mile haul at 30 MPH (3.16 cycles and 15.79 CY per hour)	TD@.063	CY	—	2.94	2.92	5.86
6 mile haul at 40 MPH (2.4 cycles and 12 CY per hour)	TD@.083	CY	—	3.87	3.84	7.71
10 CY dump truck. Use \$800 as a minimum job charge.						
1 mile haul at 20 MPH (4.62 cycles and 46.15 CY per hour)	TD@.022	CY	—	1.03	2.13	3.16
3 mile haul at 30 MPH (3.16 cycles and 31.58 CY per hour)	TD@.032	CY	—	1.49	3.09	4.58
6 mile haul at 40 MPH (2.4 cycles and 24 CY per hour)	TD@.042	CY	—	1.96	4.06	6.02
25 CY off-highway dump truck. Use \$2,000 as a minimum job charge.						
1 mile haul at 20 MPH (4.62 cycles and 115.38 CY per hour)	TD@.009	CY	—	.42	1.30	1.72
3 mile haul at 30 MPH (3.16 cycles and 78.95 CY per hour)	TD@.013	CY	—	.61	1.88	2.49
6 mile haul at 40 MPH (2.4 cycles and 60 CY per hour)	TD@.017	CY	—	.79	2.46	3.25

31 Earthwork

	Craft@Hrs	Unit	Material	Labor	Equipment	Total
Dozer Excavation Mass excavation using a crawler tractor with a dozing blade. Costs shown include excavation and pushing soil 150' to a stockpile. Based on good access and a maximum of 5% grade. Increase or reduce costs 20% for each 50' of push more or less than 150'. Cubic yards (CY) per hour shown are undisturbed bank measure and are based on a 1-man crew. Use the following as minimum job charges: \$850 if using a D-4 or a D-6 dozer; \$1,350 if using a D-7 or D-8 dozer; or \$2,000 if using a D-9 dozer.						
Gravel or loose sand						
100 HP D-4 dozer with "S"-blade (29 CY per hour)	T0@.034	CY	—	1.96	2.15	4.11
140 HP D-6 dozer with "S"-blade (56 CY per hour)	T0@.018	CY	—	1.04	1.54	2.58
200 HP D-7 dozer with "S"-blade (78 CY per hour)	T0@.013	CY	—	.75	1.60	2.35
335 HP D-8 dozer with "U"-blade (140 CY per hour)	T0@.007	CY	—	.40	1.16	1.56
460 HP D-9 dozer with "U"-blade (205 CY per hour)	T0@.005	CY	—	.29	1.32	1.61
Loam or soft clay						
100 HP D-4 dozer with "S"-blade (26 CY per hour)	T0@.038	CY	—	2.20	2.41	4.61
140 HP D-6 dozer with "S"-blade (50 CY per hour)	T0@.020	CY	—	1.16	1.71	2.87
200 HP D-7 dozer with "S"-blade (70 CY per hour)	T0@.014	CY	—	.81	1.72	2.53
335 HP D-8 dozer with "U"-blade (125 CY per hour)	T0@.008	CY	—	.46	1.33	1.79
460 HP D-9 dozer with "U" blade (185 CY per hour)	T0@.005	CY	—	.29	1.33	1.62
Shale, sandstone or blasted rock						
100 HP D-4 dozer with "S"-blade (20 CY per hour)	T0@.051	CY	—	2.95	3.23	6.18
140 HP D-6 dozer with "S"-blade (38 CY per hour)	T0@.026	CY	—	1.50	2.23	3.73
200 HP D-7 dozer with "S"-blade (53 CY per hour)	T0@.019	CY	—	1.10	2.34	3.44
335 HP D-8 dozer with "U"- blade (95 CY per hour)	T0@.011	CY	—	.64	1.82	2.46
460 HP D-9 dozer with "U"- blade (140 CY per hour)	T0@.007	CY	—	.40	1.85	2.25
Scraper-Hauler Excavation Mass excavation using a self-propelled scraper-hauler. Equipment costs include the scraper-hauler and a crawler tractor with a dozer blade attached pushing for 10 minutes each hour. Cubic yards (CY) per hour shown are undisturbed bank measure. Work done in clay, shale or soft rock will cost 10% to 25% more.						
15 CY self-propelled 200 HP scraper-hauler and a D-8 335 HP tractor pushing. Use \$6,000 as a minimum job charge.						
1,000' haul (9 cycles and 135 CY per hr)	SS@.016	CY	—	.82	1.59	2.41
2,500' haul (6 cycles and 90 CY per hr)	SS@.024	CY	—	1.23	2.38	3.61
4,000' haul (4.5 cycles and 68 CY per hr)	SS@.032	CY	—	1.65	3.18	4.83
24 CY self-propelled 350 HP scraper-hauler and a D-9 460 HP tractor pushing. Use \$8,000 as a minimum job charge.						
1,000' haul (9 cycles and 225 CY per hr)	SS@.010	CY	—	.52	1.44	1.96
2,500' haul (6 cycles and 150 CY per hr)	SS@.014	CY	—	.73	2.02	2.75

31 Earthwork

	Craft@Hrs	Unit	Material	Labor	Equipment	Total
4,000' haul (4.5 cycles and 113 CY per hr)	SS@.019	CY	—	.98	2.74	3.72
32 CY self-propelled 550 HP scraper-hauler and a D-9 460 HP tractor pushing. Use \$10,000 as a minimum job charge.						
1,000' haul (9 cycles and 315 CY per hr)	SS@.007	CY	—	.37	.85	1.22
2,500' haul (6 cycles and 219 CY per hr)	SS@.010	CY	—	.52	1.21	1.73
4,000' haul (4.5 cycles and 158 CY per hr)	SS@.014	CY	—	.73	1.70	2.43
Manual Excavation Based on one throw (except where noted) of shoveled earth from a trench or pit. Shoring or dewatering is not included.						
Trench or pit in light soil (silty sand or loess, etc.)						
Up to 4' deep (.82 CY per hour)	CL@1.22	CY	—	50.80	—	50.80
Over 4' to 6' deep (.68 CY per hour)	CL@1.46	CY	—	60.80	—	60.80
Over 6' deep, two throws (.32 CY per hour)	CL@3.16	CY	—	132.00	—	132.00
Trench or pit in medium soil (sandy clay, for example)						
Up to 4' deep (.68 CY per hour)	CL@1.46	CY	—	60.80	—	60.80
Over 4' to 6' deep (.54 CY per hour)	CL@1.86	CY	—	77.50	—	77.50
Over 6' deep, two throws (.27 CY per hour)	CL@3.66	CY	—	152.00	—	152.00
Trench or pit in heavy soil (clayey materials, shales, caliche, etc.)						
Up to 4' deep (.54 CY per hour)	CL@1.86	CY	—	77.50	—	77.50
Over 4' to 6' deep (.46 CY per hour)	CL@2.16	CY	—	90.00	—	90.00
Over 6' deep, 2 throws (.25 CY per hour)	CL@3.90	CY	—	162.00	—	162.00
Wheelbarrow (5 CF) on firm ground, load by shovel from pile, wheel 300 feet and dump						
Light soil (.74 CY per hour)	CL@1.35	CY	—	56.20	—	56.20
Medium soil (.65 CY per hour)	CL@1.54	CY	—	64.20	—	64.20
Heavy soil (.56 CY per hour)	CL@1.79	CY	—	74.60	—	74.60
Loose rock (.37 CY per hour)	CL@2.70	CY	—	112.00	—	112.00
Hand trim and shape						
Around utility lines (15 CF hour)	CL@.065	CF	—	2.71	—	2.71
For slab on grade (63 SY per hour)	CL@.016	SY	—	.67	—	.67
Trench bottom (100 SF per hour)	CL@.010	SF	—	.42	—	.42

Wellpoint Dewatering Based on header pipe connecting 2" diameter jetted wellpoints 5' on center. Includes header pipe, wellpoints, filter sand, pumps and swing joints. The header pipe length is usually equal to the perimeter of the area excavated.

Typical cost for installation and removal of wellpoint system with wellpoints 14' deep and placed 5' on center along 6" header pipe. Based on equipment rented for 1 month. Use 100 LF as a minimum job charge. Add the cost of an operator/attendant if required. Also add (if required) for additional months of rental, fuel for the pumps, a standby pump, water truck for jetting, outflow pipe, permits and consultant costs.

6" header pipe and accessories, system per LF installed, rented 1 month and removed

100 LF system	C5@.535	LF	1.86	25.10	26.60	53.56
200 LF system	C5@.535	LF	1.86	25.10	26.60	53.56
500 LF system	C5@.535	LF	1.86	25.10	26.60	53.56
1,000 LF system	C5@.535	LF	1.86	25.10	26.60	53.56
Add for 8" header pipe	C5@.010	LF	.05	.47	2.04	2.56
Add for 18' wellpoint depth	C5@.096	LF	.14	4.51	6.72	11.37
Add for second month	—	LF	—	—	20.40	14.30
Add for each additional month	—	LF	—	—	11.80	8.52
Add for operator, per hour	T0@1.00	Hr	—	57.80	—	57.80

31 Earthwork

	Craft@Hrs	Unit	Material	Labor	Equipment	Total
Roadway and Embankment Earthwork Cut & Fill Mass excavating, hauling, placing and compacting (cut & fill) using a 200 HP, 15 CY capacity self-propelled scraper-hauler with attachments. Productivity is based on a 1,500' haul with 6" lifts compacted to 95% per AASHTO requirements. Cubic yards (CY) or square yards (SY) per hour shown are bank measurement. Use \$3,000 as a minimum job charge.						
Cut, fill and compact, clearing or finishing not included						
Most soil types (45 CY per hour)	T0@.022	CY	—	1.27	3.88	5.15
Rock and earth mixed (40 CY per hour)	T0@.025	CY	—	1.44	4.41	5.85
Rippable rock (25 CY per hour)	T0@.040	CY	—	2.31	7.06	9.37
Earth banks and levees, clearing or finishing not included						
Cut, fill and compact (85 CY per hour)	T0@.012	CY	—	.69	2.12	2.81
Channelize compacted fill (55 CY per hour)	T0@.018	CY	—	1.04	3.18	4.22
Roadway subgrade preparation						
Scarify and compact (91 CY per hour)	T0@.011	CY	—	.64	1.94	2.58
Roll and compact base course (83 CY per hour)	T0@.012	CY	—	.69	2.12	2.81
Excavation, open ditches (38 CY per hour)	T0@.026	CY	—	1.50	4.59	6.09
Trimming and finishing						
Banks, swales or ditches (140 CY per hour)	T0@.007	CY	—	.40	1.23	1.63
Scarify asphalt pavement (48 SY per hour)	T0@.021	SY	—	1.21	3.70	4.91
Soil Covers						
Using staked straw erosion control blanket	CL@.019	SY	.83	.79	—	1.62
Staked 8" straw wattle	CL@0.23	LF	1.32	9.58	—	10.90
Using copolymer-base sprayed-on liquid soil sealant						
On slopes for erosion control	CL@.012	SY	1.75	.50	—	2.25
On level ground for dust abatement	CL@.012	SY	3.50	.50	—	4.00
Soil Stabilization See also Slope Protection. Lime slurry injection treatment. Equipment is a 100 HP grader, a 1-ton self-propelled steel roller and a 10-ton 100 HP vibratory steel roller. Use \$3,000 as a minimum job charge. Cost per CY of soil treated.						
(25 CY per hour)	S7@.240	CY	17.70	11.90	9.41	39.01
Vibroflotation treatment Equipment includes a 50-ton hydraulic crane, a 1 CY wheel loader for 15 minutes of each hour, and a vibroflotation machine with pumps. Use \$3,500 as a minimum job charge. Typical cost per CY of soil treated.						
Low cost (92 CY per hour)	S7@.065	CY	—	3.23	3.59	6.82
High cost (46 CY per hour)	S7@.130	CY	—	6.46	7.19	13.65
Soil cement treatment Includes materials and placement for 7% cement mix. Equipment is a cross shaft mixer, a 2-ton 3-wheel steel roller and a vibratory roller. Costs shown are per CY of soil treated. Use \$3,000 as a minimum job charge.						
On level ground						
(5 CY per hour)	S7@1.20	CY	14.90	59.70	31.10	105.70
On slopes under 3 in 1						
(4.3 CY per hour)	S7@1.40	CY	14.90	69.60	36.30	120.80
On slopes over 3 in 1						
(4 CY per hour)	S7@1.50	CY	14.90	74.60	38.90	128.40
Construction fabrics (geotextiles) Mirafi products. Costs shown include 10% for lapover. Drainage fabric (Mirafi 140NC), used to line trenches, allows water passage but prevents soil migration into drains.						
Per SY of fabric placed by hand	CL@.016	SY	1.17	.67	—	1.84
Stabilization fabric (Mirafi 500X), used to prevent mixing of unstable soils with road base aggregate						
Per SY of fabric placed by hand	CL@.008	SY	.96	.33	—	1.29
Prefabricated drainage fabric (Miradrain), used to drain subsurface water from structural walls						
Per SY of fabric placed by hand	CL@.006	SY	1.07	.25	—	1.32
Erosion control mat (Miramat TM8), used to reduce surface soil erosion on slopes or in ditches while promoting seed growth						
Per SY of mat placed by hand	CL@.020	SY	.71	.83	—	1.54

31 Earthwork

	Craft@Hrs	Unit	Material	Labor	Equipment	Total
Slope Protection See also Soil Stabilization. Gabions as manufactured by Maccaferri Inc. Typical prices for gabions as described, placed by hand. Prices can be expected to vary based on quantity. Cost for stone is not included. Add for stone as required. Costs shown are per each gabion.						
Galvanized mesh						
6' x 3' x 3'	CL@2.70	Ea	237.00	112.00	—	349.00
9' x 3' x 3'	CL@2.90	Ea	139.00	121.00	—	260.00
12' x 3' x 3'	CL@3.10	Ea	294.00	129.00	—	423.00
Erosion and drainage control polypropylene geotextile fabric (Mirafi FW700)						
For use under riprap, hand placed	CL@.011	SY	2.83	.46	—	3.29
Riprap Dumped from trucks and placed using a 15-ton hydraulic crane and a 10 CY dump truck. Riprap costs will vary widely. Add \$1.00 per CY per mile for trucking to the site. Cubic yards (CY) per hour shown in parentheses are based on a 7-man crew. Use \$2,500 as a minimum job charge.						
Typical riprap cost, per CY	—	CY	92.60	—	—	92.60
5 to 7 CF pieces (9.4 CY per hour)	\$5@.745	CY	92.60	33.30	16.40	142.30
5 to 7 CF pieces, sacked and placed, excluding bag cost (3 CY per hour)	\$5@2.33	CY	92.60	104.00	51.30	247.90
Loose small riprap stone, under 30 lbs each, hand placed (2 CY per hour)	CL@.500	CY	92.60	20.80	—	113.40
Ornamental large rock Rock prices include local delivery of 10 CY minimum. Cubic yards (CY) per hour shown in parentheses are based on a 7-man crew. Equipment is a 15-ton hydraulic crane and a 10 CY dump truck. Use \$2,500 as a minimum job charge. Expect wide variation in costs of ornamental rock.						
Volcanic cinder, 1,200 lbs per CY (8 CY per hour)						
	\$5@.875	CY	452.00	39.10	19.30	510.40
Featherock, 1,000 lbs per CY (12 CY per hour)						
	\$5@.583	CY	497.00	26.10	12.90	536.00
Rock fill Dumped from trucks and placed with a 100 HP D-4 tractor. Rock prices include local delivery of 10 CY minimum. Cubic yards (CY) per hour shown in parentheses are based on a 3-man crew. Use \$1,350 as a minimum job charge.						
Drain rock, 3/4" to 1-1/2" (12 CY per hour)						
	\$6@.250	CY	35.70	11.80	5.28	52.78
Bank run gravel (12 CY per hour)						
	\$6@.250	CY	39.70	11.80	5.28	56.78
Pea gravel (12 CY per hour)						
	\$6@.250	CY	39.70	11.80	5.28	56.78
Straw bales secured to ground with driven reinforcing bars, bale is 3'6" long, 2' wide, 1'6" high.						
Per bale of straw, placed by hand	CL@.166	Ea	13.00	6.92	—	19.92
Sedimentation control fence, installed vertically at bottom of slope, with stakes attached, 36" high woven fabric (Mirafi 100X)						
	CL@.003	LF	.38	.12	—	.50
Stone tracking pad Washed 3" to 6" stone placed and removed at the site entrance to clean sediment from the tires of vehicles exiting the site. Typical size is 24' wide x 50' long x 12" deep (45 CY) Equipment is a wheel-mounted front end loader. Add the cost of excavation, bedding material and backfill if required.						
Per cubic yard, placed and removed	\$6@.250	CY	40.40	11.80	7.17	59.37
Per pad 24' W x 50' L x 12" D (45 CY)	\$6@.250	Ea	1,820.00	11.80	322.00	2,153.80
Per pad 24' W x 50' L x 6" D (23 CY)	\$6@.250	Ea	929.00	11.80	163.00	1,103.80
Add for geotextile liner (muddy site)	CL@.020	SY	.69	.83	—	1.52
Drain inlet protection Sediment control for drains and curb inlets to meet National Pollutant Discharge Elimination System (NPDES) and state permit requirements.						
Poly 14" x 21" sandbags						
Sandbag filled with 40 lb. of gravel, placed and removed, no salvage	CL@.083	Ea	1.00	3.46	—	4.46
Sandbag barrier for a 5' curb inlet, 25 bags, placed and removed, no salvage						
	CL@2.08	Ea	24.90	86.70	—	111.60
Mulch-filled erosion control 8" diameter fiber sock, staked per liner foot of sock, no salvage						
	CL@.040	LF	1.32	1.67	—	2.99

31 Earthwork

	Craft@Hrs	Unit	Material	Labor	Equipment	Total
One-piece curb inlet and magnetic drain grate filter, 2' wide, 4' long inlet	CL@.340	LF	89.00	14.20	—	103.20
Curb inlet filter sock						
Opening to 6' long	CL@.400	Ea	152.00	16.70	—	168.70
Opening over 6' to 8' long	CL@.400	Ea	170.00	16.70	—	186.70
Opening over 8' to 10' long	CL@.400	Ea	202.00	16.70	—	218.70
Shoring, Bulkheads and Underpinning Hot-rolled steel sheet piling, driven and pulled, based on good driving conditions and using sheets 30' to 50' in length with 32 lbs of 38.5 KSI steel per SF. Material cost assumes the piling is salvaged. Per cubic yard, placed and removed Use \$16,000 as a minimum job charge.						
Using steel at, per ton	—	Ton	1,730.00	—	—	1,730.00
Assumed steel salvage value, per ton	—	Ton	1,280.00	—	—	1,280.00
Typical driving and pulling cost, per ton	—	Ton	—	—	275.00	262.00
Up to 20' deep	S8@.096	SF	6.90	4.95	5.84	17.69
Over 20' to 35' deep	S8@.088	SF	6.90	4.54	5.39	16.83
Over 35' to 50' deep	S8@.087	SF	6.90	4.48	5.30	16.68
Over 50' deep	S8@.085	SF	6.90	4.38	5.18	16.46
Extra costs for sheet steel piling						
Add for:						
50' to 65' lengths	—	SF	.16	—	—	.16
65' to 100' lengths	—	SF	.38	—	—	.38
Epoxy coal tar 16 mil factory finish	—	SF	2.68	—	—	2.68
32 lb per SF piling material left in place	—	SF	7.40	—	—	7.40
38 lbs per SF (MZ 38) steel	—	SF	1.58	—	—	1.58
50 KSI high-strength steel	—	SF	.97	—	—	.97
Marine grade 50 KSI high strength steel	—	SF	1.69	—	—	1.69
Deductive costs for sheet steel piling						
Deduct for:						
28 lbs per SF (PS 28) steel	—	SF	-1.46	—	—	-1.46
23 lbs per SF (PS 23) steel	—	SF	-2.05	—	—	-2.05
Deduct labor & equipment cost when piling is left in place	—	SF	—	-1.50	-.59	-2.09
Timber trench sheeting and bracing per square foot of trench wall measured on one side of trench. Costs include pulling and salvage, depths to 12'. Equipment includes a 10-ton hydraulic crane and a 1-ton flat-bed truck. Use \$4,000 as a minimum job charge.						
Less than 6' wide, open bracing	S5@.053	SF	2.52	2.37	.59	5.48
6' to 10' wide, open bracing	S5@.064	SF	2.65	2.86	.66	6.17
11' to 16' wide, open bracing	S5@.079	SF	3.11	3.53	.81	7.45
Over 16' wide, open bracing	S5@.091	SF	3.41	4.07	.94	8.42
Less than 6' wide, closed sheeting	S5@.114	SF	2.89	5.10	1.17	9.16
6' to 10' wide, closed sheeting	S5@.143	SF	2.58	6.39	1.47	10.44
11' to 16' wide, closed sheeting	S5@.163	SF	3.06	7.29	1.68	12.03
Over 16' wide, closed sheeting	S5@.199	SF	3.88	8.90	2.05	14.83
Additional costs for bracing on trenches over 12' deep						
Normal bracing, to 15' deep	S5@.050	SF	.48	2.24	.52	3.24
One line of bracing, over 15' to 22' deep	S5@.053	SF	.58	2.37	.55	3.50
Two lines of bracing, over 22' to 35' deep	S5@.061	SF	.99	2.73	.63	4.35
Three lines of bracing, over 35' to 45' deep	S5@.064	SF	1.12	2.86	.66	4.64

31 Earthwork

Craft@Hrs Unit Material Labor Equipment Total

Pile Foundations These costs assume solid ground for support of the pile driving equipment with all site work performed by others at no cost prior to pile driving being performed. Costs shown per linear foot (LF) are per vertical foot of pile depth. Standby or idle time, access roads, rig mats, test piles or special engineering required by unusual conditions are not included.

Pile testing Testing costs will vary with the soil type, method of testing, and seismic requirements for any given job site. Use the following as guideline costs for estimating purposes. Typical costs including cost for moving test equipment on and off job site. Add cost below for various types of piling.

50- to 100-ton range	S8@224.	Ea	—	11,500.00	9,510.00	21,010.00
Over 100-ton to 200-ton range	S8@280.	Ea	—	14,400.00	11,900.00	26,300.00
Over 200-ton to 300-ton range	S8@336.	Ea	—	17,300.00	14,200.00	31,500.00

Prestressed concrete piles Equipment includes a 60-ton crawler mounted crane equipped with pile driving attachments, a 4-ton forklift, a truck with hand tools, a portable air compressor complete with hoses and pneumatic operated tools, a welding machine and an oxygen-acetylene cutting torch. Use \$30,000 as minimum job charge, including 1,000 LF of piling and the cost for moving the pile driving equipment on and off the job site.

Minimum job charge	—	LS	—	—	—	30,000.00
--------------------	---	----	---	---	---	-----------

For jobs requiring over 1,000 LF of piling, add to minimum charge as follows. (Figures in parentheses show approximate production per day based on a 7-man crew.)

12" square

30' or 40' long piles (550 LF per day)	S8@.102	LF	21.30	5.26	5.60	32.16
50' or 60' long piles (690 LF per day)	S8@.082	LF	21.30	4.23	4.50	30.03

14" square

30' or 40' long piles (500 LF per day)	S8@.113	LF	26.10	5.82	6.21	38.13
50' or 60' long piles (645 LF per day)	S8@.087	LF	26.10	4.48	4.78	35.36

16" square

30' or 40' long piles (420 LF per day)	S8@.134	LF	37.20	6.91	7.36	51.47
50' or 60' long piles (550 LF per day)	S8@.102	LF	37.20	5.26	5.60	48.06

18" square

30' or 40' long piles (400 LF per day)	S8@.143	LF	46.40	7.37	7.85	61.62
50' or 60' long piles (525 LF per day)	S8@.107	LF	46.40	5.51	5.88	57.79

Additional costs for prestressed concrete piles Pre-drilling holes for piles. Equipment includes a flatbed truck with a boom and a power-operated auger. Use \$2,200 as a minimum job charge, including drilling 100 LF of holes and the cost to move the drilling equipment on and off the job site.

Minimum job charge	—	LS	—	—	—	2,200.00
--------------------	---	----	---	---	---	----------

For jobs requiring more than 100 LF of holes drilled, add to minimum cost as shown below

Pre-drilling first 10 LF, per hole	C9@1.50	LS	—	74.70	63.20	137.90
------------------------------------	---------	----	---	-------	-------	--------

Add per LF of drilling,

after first 10 LF	C9@.177	LF	—	8.82	7.46	16.28
-------------------	---------	----	---	------	------	-------

Steel "HP" shape piles Equipment includes a 60-ton crawler-mounted crane equipped with pile driving attachments, a 4-ton forklift, a truck with hand tools, a portable air compressor complete with hoses and pneumatic operated tools, a welding machine and an oxygen-acetylene cutting torch. Use \$20,000 as minimum job charge, including 1,000 LF of piling and cost for moving pile driving equipment on and off the job site.

Minimum job charge	—	LS	—	—	—	20,000.00
--------------------	---	----	---	---	---	-----------

For jobs requiring over 1,000 LF of piling add to minimum charge as follows. (Figures in parentheses show approximate production per day based on a 7-man crew.)

HP8 8" x 8", 36 lbs per LF

30' or 40' long piles (800 LF per day)	S8@.070	LF	18.50	3.61	3.84	25.95
50' or 60' long piles (880 LF per day)	S8@.064	LF	18.50	3.30	3.51	25.31

HP10 10" x 10", 42 lbs per LF

30' or 40' long piles (760 LF per day)	S8@.074	LF	21.60	3.81	4.06	29.47
50' or 60' long piles (800 LF per day)	S8@.070	LF	21.60	3.61	3.84	29.05

31 Earthwork

	Craft@Hrs	Unit	Material	Labor	Equipment	Total
HP10 10" x 10", 48 lbs per LF						
30' or 40' long piles (760 LF per day)	S8@.074	LF	24.60	3.81	4.06	32.47
50' or 60' long piles (800 LF per day)	S8@.070	LF	24.60	3.61	3.84	32.05
HP12 12" x 12", 53 lbs per LF						
30' or 40' long piles (730 LF per day)	S8@.077	LF	27.20	3.97	4.23	35.40
50' or 60' long piles (760 LF per day)	S8@.074	LF	27.20	3.81	4.06	35.07
HP12 12" x 12", 74 lbs per LF						
30' or 40' long piles (730 LF per day)	S8@.077	LF	38.00	3.97	4.23	46.20
50' or 60' long piles (760 LF per day)	S8@.074	LF	38.00	3.81	4.06	45.87
HP14 14" x 14", 73 lbs per LF						
30' or 40' long piles (690 LF per day)	S8@.081	LF	37.50	4.17	4.45	46.12
50' or 60' long piles (730 LF per day)	S8@.077	LF	37.50	3.97	4.23	45.70
HP14 14" x 14", 89 lbs per LF						
30' or 40' long piles (630 LF per day)	S8@.089	LF	45.70	4.59	4.89	55.18
50' or 60' long piles (690 LF per day)	S8@.081	LF	45.70	4.17	4.45	54.32
HP14 14" x 14", 102 lbs per LF						
30' or 40' long piles (630 LF per day)	S8@.089	LF	52.40	4.59	4.89	61.88
50' or 60' long piles (690 LF per day)	S8@.081	LF	52.40	4.17	4.45	61.02
HP14 14" x 14", 117 lbs per LF						
30' or 40' long piles (630 LF per day)	S8@.089	LF	60.00	4.59	4.89	69.48
50' or 60' long piles (690 LF per day)	S8@.081	LF	60.00	4.17	4.45	68.62
Additional costs related to any of above						
Standard driving points or splices						
HP8	S8@1.50	Ea	59.30	77.30	29.20	165.80
HP10	S8@1.75	Ea	64.30	90.20	34.00	188.50
HP12	S8@2.00	Ea	81.10	103.00	38.90	223.00
HP14	S8@2.50	Ea	93.30	129.00	48.60	270.90
Cutting pile off to required elevation						
HP8 or HP10	S8@1.00	Ea	6.43	51.50	19.50	77.43
HP12 or HP14	S8@1.50	Ea	9.68	77.30	29.20	116.18

Steel pipe piles Equipment includes a 45-ton crawler-mounted crane equipped with pile driving attachments, a 2-ton forklift, a truck with hand tools, a portable air compressor complete with hoses and pneumatic operated tools, a welding machine and an oxygen-acetylene cutting torch. Use \$20,000 as minimum job charge, including 500 LF of piling and cost for moving pile driving equipment on and off the job site.

Minimum job charge — LS — — — 20,000.00

For jobs requiring over 500 LF of piling add to minimum charge as follows. (Figures in parentheses show approximate production per day based on a 7-man crew.)

Steel pipe piles, non-filled						
8" (660 LF per day)	S8@.085	LF	14.20	4.38	3.78	22.36
10" (635 LF per day)	S8@.088	LF	20.10	4.54	3.91	28.55
12" (580 LF per day)	S8@.096	LF	24.80	4.95	4.27	34.02
14" (500 LF per day)	S8@.112	LF	27.70	5.77	4.98	38.45
16" (465 LF per day)	S8@.120	LF	31.70	6.18	5.33	43.21
18" (440 LF per day)	S8@.128	LF	36.20	6.60	5.69	48.49
Steel pipe piles, concrete filled						
8" (560 LF per day)	S8@.100	LF	16.60	5.15	4.45	26.20
10" (550 LF per day)	S8@.101	LF	21.00	5.21	4.49	30.70
12" (500 LF per day)	S8@.112	LF	27.40	5.77	4.98	38.15
14" (425 LF per day)	S8@.131	LF	29.60	6.75	5.82	42.17
16" (400 LF per day)	S8@.139	LF	35.00	7.16	6.18	48.34
18" (375 LF per day)	S8@.149	LF	40.10	7.68	6.62	54.40

31 Earthwork

	Craft@Hrs	Unit	Material	Labor	Equipment	Total
Splices for steel pipe piles						
8" pile	S8@1.12	Ea	66.10	57.70	17.90	141.70
10" pile	S8@1.55	Ea	74.20	79.90	24.80	178.90
12" pile	S8@2.13	Ea	80.10	110.00	34.10	224.20
14" pile	S8@2.25	Ea	106.00	116.00	36.00	258.00
16" pile	S8@2.39	Ea	167.00	123.00	38.30	328.30
18" pile	S8@2.52	Ea	201.00	130.00	40.40	371.40
Standard points for steel pipe piles						
8" point	S8@1.49	Ea	101.00	76.80	23.90	201.70
10" point	S8@1.68	Ea	136.00	86.60	26.90	249.50
12" point	S8@1.84	Ea	183.00	94.80	29.50	307.30
14" point	S8@2.03	Ea	229.00	105.00	32.50	366.50
16" point	S8@2.23	Ea	341.00	115.00	35.70	491.70
18" point	S8@2.52	Ea	448.00	130.00	40.40	618.40

Wood piles End bearing Douglas fir, treated with 12 lb creosote. Piles up to 40' long are 8" minimum tip diameter. Over 45' long, 7" is the minimum tip diameter. Equipment includes a 45-ton crawler-mounted crane equipped with pile driving attachments, a 2-ton forklift, a truck with hand tools, a portable air compressor complete with hoses and pneumatic operated tools. Use \$30,000 as minimum job charge, including 1,000 LF of piling and cost for moving pile driving equipment on and off the job site.

Minimum job charge — LS — — — 30,000.00

For jobs requiring over 1,000 LF of piling, add to minimum charge as follows. (Figures in parentheses show approximate production per day based on a 7-man crew.)

To 30' long (725 LF per day)	S8@.077	LF	7.64	3.97	3.19	14.80
Over 30' to 40' (800 LF per day)	S8@.069	LF	7.78	3.56	2.86	14.20
Over 40' to 50' (840 LF per day)	S8@.067	LF	8.56	3.45	2.77	14.78
Add for drive shoe, per pile	—	Ea	35.00	—	—	35.00

Caisson Foundations Drilled in stable soil, no shoring required, filled with reinforced concrete. Add for belled bottoms, if required, from the following section. Equipment includes a truck-mounted A-frame hoist and a power operated auger and a concrete pump. Concrete is based on using 3,000 PSI pump mix delivered to the job site in ready-mix trucks and includes a 5% allowance for waste. Spiral caisson reinforcing is based on using 3/8" diameter hot rolled steel spirals with main vertical bars as shown, shop fabricated, delivered ready to install, with typical engineering and drawings. Costs for waste disposal are not included. Refer to Construction Materials Disposal section and add for same. Use \$15,000 as a minimum charge, including 200 LF of reinforced concrete filled caissons and cost for moving the equipment on and off the job.

Minimum job charge — LS — — — 15,000.00

For jobs requiring over 200 LF of reinforced concrete-filled caissons, add to minimum charge as follows. (Figures in parentheses show approximate production per day based on a 3-man crew.)

16" diameter, drilled caisson filled with reinforced concrete

Drilling						
(680 VLF per day)	S6@.035	VLF	—	1.65	3.18	4.83
Spiral reinforcing plus 6 #6 bars						
(590 VLF per day)	S6@.041	VLF	41.00	1.93	3.73	46.66
Concrete filling						
(615 VLF per day)	S6@.039	VLF	7.42	1.83	3.54	12.79
Total for 16" caisson	S6@.115	VLF	48.42	5.41	10.45	64.28

31 Earthwork

	Craft@Hrs	Unit	Material	Labor	Equipment	Total
24" diameter, drilled caisson filled with reinforced concrete						
Drilling (570 VLF per day)	S6@.042	VLF	—	1.98	3.82	5.80
Spiral reinforcing plus 6 #6 bars (280 VLF per day)	S6@.085	VLF	70.40	4.00	7.72	82.12
Concrete filling (280 VLF per day)	S6@.086	VLF	16.50	4.05	7.82	28.37
Total for 24" caisson	S6@.213	VLF	86.90	10.03	19.36	116.29
36" diameter, drilled caisson filled with reinforced concrete						
Drilling (440 LF per day)	S6@.055	VLF	—	2.59	5.00	7.59
Spiral reinforcing plus 8 #10 bars (135 VLF per day)	S6@.176	VLF	127.00	8.28	16.00	151.28
Concrete filling (125 VLF per day)	S6@.194	VLF	37.30	9.13	17.60	64.03
Total for 36" caisson	S6@.425	VLF	164.30	20.00	38.60	222.90
Bell-bottom footings, concrete filled, for pre-drilled caissons. Add to the cost of any of the caissons above. (Figures in parentheses show approximate production per day based on a 3-man crew.)						
6' diameter bell bottom concrete filled (8 per day)	S6@3.00	Ea	429.00	141.00	273.00	843.00
8' diameter bell bottom concrete filled (4 per day)	S6@6.00	Ea	1,010.00	282.00	545.00	1,837.00

32 Exterior Improvements

	Craft@Hrs	Unit	Material	Labor	Equipment	Total
Asphalt Paving To arrive at the total cost for new asphalt paving jobs, add the cost of the subbase preparation and aggregate to the costs for the asphalt binder course, the rubberized interliner and the wear course. Cost for site preparation is not included. Based on roadway and parking lot jobs of 5,000 SY or more. For more detailed coverage, see <i>National Earthwork and Heavy Equipment Estimator</i> , https://craftsman-book.com/national-estimator-cloud .						
Subbase and aggregate Equipment includes a pneumatic-tired articulated 10,000 pound motor grader, a 4-ton two axle steel drum roller and a 3,500 gallon water truck.						
Fine grading and compacting existing subbase To within plus or minus 1/10'	P5@.066	SY	.01	3.03	2.75	5.79
Stone aggregate base, Class 2. Includes grading and compacting of base material.						
Class 2 stone aggregate base, per CY	—	CY	44.80	—	—	44.80
Class 2 stone aggregate base, per ton	—	Ton	32.00	—	—	32.00
1" thick base (36 SY per CY)	P5@.008	SY	1.24	.37	.33	1.94
4" thick base (9 SY per CY)	P5@.020	SY	4.97	.92	.83	6.72
6" thick base (6 SY per CY)	P5@.033	SY	7.46	1.51	1.38	10.35
8" thick base (4.5 SY per CY)	P5@.039	SY	9.95	1.79	1.63	13.37
10" thick base (3.6 SY per CY)	P5@.042	SY	12.40	1.93	1.75	16.08
12" thick base (3 SY per CY)	P5@.048	SY	14.90	2.20	2.00	19.10
Asphalt materials Equipment includes a 10' wide self-propelled paving machine and a 4-ton two axle steel drum roller						
Binder course, spread and rolled						
Binder course, per ton	—	Ton	81.30	—	—	81.30
1" thick (18 SY per ton)	P5@.028	SY	4.52	1.28	1.07	6.87
1-1/2" thick (12 SY per ton)	P5@.036	SY	6.78	1.65	1.55	9.98

32 Exterior Improvements

	Craft@Hrs	Unit	Material	Labor	Equipment	Total
2" thick (9 SY per ton)	P5@.039	SY	9.03	1.79	1.67	12.49
3" thick (6 SY per ton)	P5@.050	SY	13.60	2.29	2.15	18.04
Paving fabric interlayer with tack coat. Based on using 10' wide rolls by 378' long and one coat of mopped-on bituminous tack coat, MC70 (0.15 gallon per SY) before allowance for waste.						
Paving fabric interlayer, per 3,780 SF roll	—	Roll	1,140.00	—	—	1,140.00
Bituminous tack coat, per gallon	—	Gal	14.80	—	—	14.80
Laid, cut, mopped and rolled	P5@.005	SY	2.88	.23	.21	3.32
Asphaltic concrete curb, straight, placed during paving. Equipment includes an asphalt curbing machine						
8" x 6", placed by hand	P5@.141	LF	2.03	6.47	—	8.50
8" x 6", machine extruded	P5@.067	LF	1.85	3.07	.70	5.62
8" x 8", placed by hand	P5@.141	LF	3.25	6.47	—	9.72
8" x 8", machine extruded	P5@.068	LF	2.46	3.12	.34	5.92
Add for curved sections	P5@.034	LF	—	1.56	.17	1.73
Asphaltic concrete speed bumps, 3" high, 24" wide (135 LF and 2 tons per CY), placed on parking lot surface and rolled. See also the section on Speed Bumps and Parking Blocks following the section Pavement Striping and Marking.						
100 LF job	P5@.198	LF	1.30	9.09	2.64	13.03
Painting speed bumps, 24" wide, white	P5@.022	LF	.33	1.01	—	1.34

Asphalt Paving for Roadways, Assembly Costs On-site roadway, with 4" thick aggregate base, 2" thick asphalt binder course, rubberized asphalt interlayer, and 2" thick wear course. This is often called 4" paving over 4" aggregate base. Based on 5,000 SY job.

Fine grading and compact existing subbase	P5@.066	SY	.01	3.03	2.83	5.87
Stone aggregate base, Class 2, 4" thick	P5@.020	SY	4.83	.92	.86	6.61
Binder course 2" thick (9 SY per ton)	P5@.039	SY	9.03	1.79	1.60	12.42
Rubberized asphalt interlayer	P5@.005	SY	2.76	.23	.21	3.20
Wear course 2" thick (9 SY per ton)	P5@.039	SY	10.00	1.79	1.60	13.39
Tar emulsion protective seal coat	P5@.034	SY	2.40	1.56	1.39	5.35
Total estimated cost for typical 10' wide roadway, 4" paving over 4" aggregate base						
Cost per SY of roadway	P5@.203	SY	29.03	9.32	8.49	46.84
Cost per SF roadway	P5@.023	SF	3.23	1.04	.94	5.20
Cost per LF, 10' wide roadway	P5@.230	LF	32.30	10.40	9.40	52.10

Asphalt Paving for Parking Areas, Assembly Costs Equipment includes a 10' wide self-propelled paving machine and a 4-ton two axle steel drum roller. On-site parking lot with 6" thick aggregate base, 3" thick asphalt binder course, rubberized asphalt interliner, and 3" thick wear course. This is often called 6" paving over 6" aggregate base.

Fine grading and compact existing subbase	P5@.066	SY	.01	3.03	2.83	5.87
Stone aggregate base, Class 2, 6" thick	P5@.033	SY	7.27	1.51	1.42	10.20
Binder course 3" thick	P5@.050	SY	13.60	2.29	2.15	18.04
Rubberized asphalt interlayer	P5@.005	SY	2.76	.23	.21	3.20
Wear course 3" thick	P5@.050	SY	15.00	2.29	2.15	19.44
Tar emulsion protective seal coat	P5@.034	SY	2.40	1.56	1.46	5.42
Total estimated cost of typical 1,000 SY parking lot, 6" paving over 6" aggregate base						
Cost per SY of parking lot	P5@.238	SY	41.04	10.91	10.22	62.12
Cost per SF of parking lot	P5@.026	SF	4.56	1.21	1.14	6.91

32 Exterior Improvements

	Craft@Hrs	Unit	Material	Labor	Equipment	Total
Cold Milling of Asphalt Surface to 1" Depth Equipment includes a motorized street broom, a 20" pavement miller, two 5 CY dump trucks and a pickup truck. Hauling and disposal not included. Use \$3,000 as a minimum charge.						
Milling asphalt to 1" depth	C6@.017	SY	—	.78	.44	1.22
Asphalt Pavement Repairs to conform to existing street, strips of 100 to 500 SF. Equipment includes one wheel-mounted 150 CFM air compressor, paving breaker, jackhammer bits, one 55 HP wheel loader with integral backhoe, one medium weight pneumatic tamper, one 1-ton two axle steel roller and one 5 CY dump truck. These costs include the cost of loading and hauling to a legal dump within 6 miles. Dump fees are not included. See Waste Disposal. Asphalt pavement repairs, assembly costs. Use \$3,600 as a minimum job charge.						
Cut and remove 2" asphalt and 36" subbase	P5@.250	SY	—	11.50	8.01	19.51
Place 30" fill compacted to 90%, 6" aggregate base, 2" thick asphalt and tack coat						
30" fill (30 SY per CY at \$11.10 CY)	P5@.099	SY	.42	4.54	3.17	8.13
6" thick base (6 SY per CY)	P5@.033	SY	7.27	1.51	1.06	9.84
2" thick asphalt (9 SY per ton)	P5@.039	SY	10.00	1.79	1.25	13.04
Tar emulsion protective seal coat	P5@.034	SY	2.40	1.56	1.09	5.05
Total per SY	P5@.455	SY	20.09	20.90	14.58	55.57
Asphalt overlay on existing asphalt pavement. Equipment includes a 10' wide self-propelled paving machine and a 4-ton two axle steel drum roller. Costs shown assume unobstructed access to the area receiving overlay. Use \$6,000 as a minimum job charge.						
Paving fabric interlayer with tack coat. Based on using 10' wide rolls x 378' long and one coat of mopped-on bituminous tack coat, MC70 (with .15 gallon per SY) before allowance for waste.						
Paving fabric interlayer, per 3,870 SF roll	—	Roll	1,140.00	—	—	1,140.00
Bituminous tack coat, per gallon	—	Gal	14.80	—	—	14.80
Laid, cut, mopped and rolled	P5@.005	SY	2.88	.23	.21	3.32
Wear course						
Bituminous wear course, per ton	—	Ton	90.30	—	—	90.30
1" thick (18 SY per ton)	P5@.028	SY	5.01	1.28	1.20	7.49
1-1/2" thick (12 SY per ton)	P5@.036	SY	7.52	1.65	1.55	10.72
2" thick (9 SY per ton)	P5@.039	SY	10.00	1.79	1.67	13.46
3" thick (6 SY per ton)	P5@.050	SY	15.00	2.29	1.67	18.96
Add to overlaid paving as described above, if required						
Bituminous prime coat, MC70	P5@.001	SY	.40	.05	.05	.50
Tar emulsion protective seal coat	P5@.034	SY	2.23	1.56	1.46	5.25
Asphalt slurry seal	P5@.043	SY	.79	1.97	1.85	4.61
Concrete Paving No grading or base preparation included.						
Steel edge forms to 15", rented	C8@.028	LF	—	1.33	.96	2.29
2,000 PSI concrete placed directly from the chute of a ready-mix truck, vibrated and broom finished. Costs include 4% allowance for waste but no forms, reinforcing, or joints.						
4" thick (80 SF per CY)	P8@.013	SF	1.61	.61	.03	2.25
6" thick (54 SF per CY)	P8@.016	SF	2.41	.75	.03	3.19
8" thick (40 SF per CY)	P8@.019	SF	3.22	.89	.04	4.15
10" thick (32 SF per CY)	P8@.021	SF	4.04	.98	.04	5.06
12" thick (27 SF per CY)	P8@.024	SF	4.84	1.12	.05	6.01
15" thick (21 SF per CY)	P8@.028	SF	6.15	1.30	.06	7.36

32 Exterior Improvements

	Craft@Hrs	Unit	Material	Labor	Equipment	Total
Clean and Sweep Pavement Equipment cost is \$53.00 per hour for a self-propelled vacuum street sweeper, 7 CY maximum capacity. Use \$300 as a minimum charge for sweeping using this equipment.						
Pavement sweeping, using equipment	T0@.200	MSF	—	11.60	23.90	35.50
Clean and sweep pavement, by hand	CL@1.44	MSF	—	60.00	—	60.00
Joint Treatment for Concrete Pavement Seal joint in concrete pavement with ASTM D5893 and FAA P-605 low modulus silicone joint sealer, including 5% waste. Cost per linear foot (LF), by joint size.						
One part silicone joint sealant	—	Gal	113.00	—	—	113.00
3/8" x 1/2" (128 LF per gallon)	PA@.002	LF	.93	.11	—	1.04
1/2" x 1/2" (96 LF per gallon)	PA@.002	LF	1.23	.11	—	1.34
1/2" x 3/4" (68 LF per gallon)	PA@.003	LF	1.74	.16	—	1.90
1/2" x 1" (50 LF per gallon)	PA@.003	LF	2.37	.16	—	2.53
1/2" x 1-1/4" (40 LF per gallon)	PA@.004	LF	2.96	.22	—	3.18
1/2" x 1-1/2" (33 LF per gallon)	PA@.006	LF	3.59	.32	—	3.91
3/4" x 3/4" (46 LF per gallon)	PA@.004	LF	2.58	.22	—	2.80
3/4" x 1-1/4" (33 LF per gallon)	PA@.006	LF	3.59	.32	—	3.91
3/4" x 1-1/2" (27 LF per gallon)	PA@.007	LF	4.39	.38	—	4.77
3/4" x 2" (22 LF per gallon)	PA@.008	LF	5.39	.43	—	5.82
1" x 1" (25 LF per gallon)	PA@.008	LF	4.74	.43	—	5.17
Deduct for asphalt emulsion sealant	—	%	-86.0	—	—	—
Backer rod for joints in concrete pavement						
1/2" backer rod	PA@.002	LF	.14	.11	—	.25
3/4" backer rod	PA@.002	LF	.23	.11	—	.34
1" backer rod	PA@.002	LF	.51	.11	—	.62
Clean out old joint sealer in concrete pavement by sandblasting and reseal with PVC coal tar sealer, including new backer rod. Use \$400 as a minimum job charge.						
1/2" x 1/2"	PA@.009	LF	.52	.48	.33	1.33
1/2" x 3/4"	PA@.013	LF	.68	.70	.48	1.86
1/2" x 1"	PA@.013	LF	.88	.70	.48	2.06
1/2" x 1-1/4"	PA@.018	LF	1.06	.97	.67	2.70
1/2" x 1-1/2"	PA@.022	LF	1.26	1.18	.81	3.25
Craft@Hrs Unit Material Labor Total						
Brick Paving Extruded hard red brick. These costs do not include site preparation. Material costs shown include 2% for waste. (Figures in parentheses show quantity of brick before allowance for waste.) For expanded coverage of brick paving, see the <i>National Concrete & Masonry Estimator</i> , https://craftsman-book.com/national-estimator-cloud .						
Brick laid flat without mortar						
Using brick, per thousand	—	M	362.00	—	—	362.00
Running bond						
4" x 8" x 2-1/4" (4.5 per SF)	M1@.114	SF	1.63	5.49	—	7.12
4" x 8" x 1-5/8" (4.5 per SF)	M1@.112	SF	1.56	5.40	—	6.96
3-5/8" x 7-5/8" x 2-1/4" (5.2 per SF)	M1@.130	SF	1.81	6.26	—	8.07
3-5/8" x 7-5/8" x 1-5/8" (5.2 per SF)	M1@.127	SF	1.81	6.12	—	7.93
Add for herringbone pattern	M1@.033	SF	—	1.59	—	1.59
Basketweave						
4" x 8" x 2-1/4" (4.5 per SF)	M1@.133	SF	1.66	6.41	—	8.07
4" x 8" x 1-5/8" (4.5 per SF)	M1@.130	SF	1.60	6.26	—	7.86
Brick laid on edge without mortar						
Running bond						
4" x 8" x 2-1/4" (8 per SF)	M1@.251	SF	2.94	12.10	—	15.04
3-5/8" x 7-5/8" x 2-1/4" (8.4 per SF)	M1@.265	SF	2.99	12.80	—	15.79
Brick laid flat with 3/8" mortar joints and mortar setting bed. Mortar included in material cost.						
Running bond						
4" x 8" x 2-1/4" (3.9 per SF)	M1@.127	SF	2.29	6.12	—	8.41
4" x 8" x 1-5/8" (3.9 per SF)	M1@.124	SF	2.24	5.97	—	8.21

32 Exterior Improvements

	Craft@Hrs	Unit	Material	Labor	Total
3-5/8" x 7-5/8" x 2-1/4" (4.5 per SF)	M1@.144	SF	2.51	6.94	9.45
3-5/8" x 7-5/8" x 1-5/8" (4.5 per SF)	M1@.140	SF	2.45	6.75	9.20
Add for herringbone pattern	M1@.033	SF	—	1.59	1.59
Basketweave					
4" x 8" x 2-1/4" (3.9 per SF)	M1@.147	SF	1.44	7.08	8.52
4" x 8" x 1-5/8" (3.9 per SF)	M1@.144	SF	1.39	6.94	8.33
3-5/8" x 7-5/8" x 2-1/4" (4.5 per SF)	M1@.147	SF	1.66	7.08	8.74
3-5/8" x 7-5/8" x 1-5/8" (4.5 per SF)	M1@.144	SF	1.60	6.94	8.54
Brick laid on edge with 3/8" mortar joints and setting bed, running bond, including mortar					
4" x 8" x 2-1/4" (6.5 per SF)	M1@.280	SF	3.24	13.50	16.74
3-5/8" x 7-5/8" x 2-1/4" (6.9 per SF)	M1@.314	SF	3.39	15.10	18.49
Mortar color for brick laid in mortar, add per SF of paved area					
Add for red or yellow	—	SF	.10	—	.10
Add for black or brown	—	SF	.15	—	.15
Add for green	—	SF	.39	—	.39
Base underlayment for paving brick					
Add for 2" sand base (124 SFper ton)	M1@.009	SF	.24	.43	.67
Add for 15 lb felt underlayment	M1@.002	SF	.05	.10	.15
Add for asphalt tack coat (80 SF per gallon)	M1@.005	SF	.04	.24	.28
Add for 2% neoprene tack coat (40 SF per gal.)	M1@.005	SF	.21	.24	.45
Brick edging, 8" deep, set in concrete with dry joints					
Using brick, per thousand	—	M	361.00	—	361.00
Headers 4" x 8" x 2-1/4" (3 per LF)	M1@.147	LF	1.08	7.08	8.16
Headers 3-5/8" x 7-5/8" x 2-1/4" (3.3 per LF)	M1@.159	LF	1.19	7.66	8.85
Rowlocks 3-5/8" x 7-5/8" x 2-1/4" (5.3 per LF)	M1@.251	LF	1.91	12.10	14.01
Rowlocks 4" x 8" x 2-1/4" (5.3 per LF)	M1@.265	LF	1.91	12.80	14.71
Brick edging, 8" deep, set in concrete with 3/8" mortar joints					
Using brick, per thousand	—	M	362.00	—	362.00
Headers 4" x 8" x 2-1/4" (2.75 per LF)	M1@.159	LF	1.00	7.66	8.66
Headers 3-5/8" x 7-5/8" x 2-1/4" (3 per LF)	M1@.173	LF	1.09	8.34	9.43
Rowlocks 3-5/8" x 7-5/8" x 2-1/4" (4.6 per LF)	M1@.298	LF	1.66	14.40	16.06
Rowlocks 4" x 8" x 2-1/4" (4.6 per LF)	M1@.314	LF	1.66	15.10	16.76
Masonry, Stone and Slate Paving These costs do not include site preparation. Costs for stone and slate vary widely. (Quantities shown in parentheses are before waste allowance.) Use \$500 as a minimum job charge.					
Interlocking 9" x 4-1/2" concrete pavers, dry joints, natural gray					
2-3/8" thick (3.5 per SF)	M1@.058	SF	3.33	2.79	6.12
3-1/8" thick (3.5 per SF)	M1@.063	SF	3.59	3.04	6.63
Add for standard colors (3.5 per SF)	—	SF	.25	—	.25
Add for custom colors (3.5 per SF)	—	SF	.52	—	.52
Patio blocks, 8" x 16" x 2", dry joints					
Natural gray (1.125 per SF)	M1@.052	SF	1.68	2.51	4.19
Standard colors (1.125 per SF)	M1@.052	SF	1.87	2.51	4.38
Flagstone pavers in sand bed with dry joints					
Random ashlar, 1-1/4"	M1@.193	SF	3.97	9.30	13.27
Random ashlar, 2-1/2"	M1@.228	SF	5.97	11.00	16.97
Irregular fitted, 1-1/4"	M1@.208	SF	3.31	10.00	13.31
Irregular fitted, 2-1/2"	M1@.251	SF	5.08	12.10	17.18
Flagstone pavers in mortar bed with mortar joints. Add the cost of mortar below					
Random ashlar, 1-1/4"	M1@.208	SF	4.06	10.00	14.06
Random ashlar, 2-1/2"	M1@.251	SF	6.16	12.10	18.26
Irregular fitted, 1-1/4"	M1@.228	SF	3.41	11.00	14.41
Irregular fitted, 2-1/2"	M1@.277	SF	5.20	13.30	18.50

32 Exterior Improvements

	Craft@Hrs	Unit	Material	Labor	Total
Granite pavers, gray, sawn, thermal finish, 3/4" joint. Add bedding costs from the section that follows					
4" x 4" x 2" thick	M1@.184	SF	31.10	8.87	39.97
4" x 4" x 3" thick	M1@.184	SF	37.20	8.87	46.07
4" x 4" x 4" thick	M1@.184	SF	42.20	8.87	51.07
4" x 8" x 2" thick	M1@.171	SF	27.00	8.24	35.24
4" x 8" x 3" thick	M1@.184	SF	30.50	8.87	39.37
4" x 8" x 4" thick	M1@.184	SF	33.60	8.87	42.47
8" x 8" x 2" thick	M1@.171	SF	22.10	8.24	30.34
8" x 8" x 3" thick	M1@.171	SF	23.90	8.24	32.14
8" x 8" x 4" thick	M1@.184	SF	25.80	8.87	34.67
12" x 12" x 2" thick	M1@.171	SF	10.90	8.24	19.14
12" x 12" x 3" thick	M1@.171	SF	12.80	8.24	21.04
12" x 12" x 4" thick	M1@.171	SF	13.70	8.24	21.94
Mortar bed, 1/2" thick, 24 SF per CF of mortar					
SF of bed	M1@.039	SF	.48	1.88	2.36
Sand bed, 2" thick, 150 SF per CY of sand					
Per SF of bed	M1@.024	SF	.24	1.16	1.40
Limestone flag paving					
Sand bed, dry joints					
Random ashlar, 1-1/4"	M1@.193	SF	4.33	9.30	13.63
Random ashlar, 2-1/2"	M1@.228	SF	8.27	11.00	19.27
Irregular fitted, 1-1/2"	M1@.208	SF	3.76	10.00	13.76
Irregular fitted, 2-1/2"	M1@.251	SF	6.39	12.10	18.49
Mortar bed and joints					
Random ashlar, 1"	M1@.208	SF	3.62	10.00	13.62
Random ashlar, 2-1/2"	M1@.251	SF	7.93	12.10	20.03
Irregular fitted, 1"	M1@.228	SF	3.26	11.00	14.26
Irregular fitted, 2-1/2"	M1@.277	SF	6.08	13.30	19.38
Slate flag paving, natural cleft					
Sand bed, dry joints					
Random ashlar, 1-1/4"	M1@.173	SF	13.20	8.34	21.54
Irregular fitted, 1-1/4"	M1@.193	SF	12.40	9.30	21.70
Mortar bed and joints					
Random ashlar, 3/4"	M1@.173	SF	10.10	8.34	18.44
Random ashlar, 1"	M1@.208	SF	11.70	10.00	21.70
Irregular fitted, 3/4"	M1@.193	SF	9.40	9.30	18.70
Irregular fitted, 1"	M1@.228	SF	10.90	11.00	21.90
Add for sand rubbed slate	—	SF	2.24	—	2.24

	Craft@Hrs	Unit	Material	Labor	Equipment	Total
--	-----------	------	----------	-------	-----------	-------

Curbs, Gutters and Driveway Aprons Costs assume 3 uses of the forms and 2,000 PSI concrete placed directly from the chute of a ready-mix truck. Concrete cast-in-place curb. Excavation or backfill not included. Use \$750 as a minimum job charge.

Curbs

Using concrete, per cubic yard	—	CY	126.00	—	—	126.00
Vertical curb						
6" x 12" straight curb	P9@.109	LF	6.64	5.34	1.63	13.61
6" x 12" curved curb	P9@.150	LF	6.75	7.35	2.25	16.35
6" x 18" straight curb	P9@.119	LF	9.87	5.83	1.78	17.48
6" x 18" curved curb	P9@.166	LF	10.00	8.14	2.49	20.63
6" x 24" straight curb	P9@.123	LF	13.10	6.03	1.84	20.97
6" x 24" curved curb	P9@.179	LF	13.20	8.77	2.68	24.65

32 Exterior Improvements

	Craft@Hrs	Unit	Material	Labor	Equipment	Total
Rolled curb and gutter, 6" roll						
6" x 18" base, straight curb	P9@.143	LF	13.10	7.01	2.14	22.25
6" x 18" base, curved curb	P9@.199	LF	13.20	9.75	2.98	25.93
6" x 24" base, straight curb	P9@.168	LF	16.50	8.23	2.52	27.25
6" x 24" base, curved curb	P9@.237	LF	16.70	11.60	3.55	31.85
Driveway aprons. Concrete cast-in-place driveway aprons, including 4% waste, wire mesh, forms and finishing. Per square foot of apron, no site preparation included. Use \$200 as a minimum job charge.						
4" thick (80 SF per CY)	P9@.024	SF	3.19	1.18	.25	4.62
6" thick (54 SF per CY)	P9@.032	SF	4.02	1.57	.34	5.93
Walkways Concrete, 2,000 PSI placed directly from the chute of a ready-mix truck, vibrated, plain scored, and broom finished. Costs include 2% allowance for waste but no forms or reinforcing.						
4" thick (80 SF per CY)	P8@.013	SF	1.65	.61	.03	2.29
Add for integral colors, most pastels	—	SF	2.14	—	—	2.14
Add for 1/2" color top course	P8@.012	SF	2.14	.56	.03	2.73
Add for steel trowel finish	CM@.011	SF	—	.57	.05	.62
Add for seeded aggregate finish	CM@.011	SF	.19	.57	.05	.81
Add for exposed aggregate wash process	CM@.006	SF	.08	.31	.03	.42
Asphalt walkway, temporary, including installation and breakout, but no hauling. Use \$500 as a minimum job charge.						
2" to 2-1/2" thick	P5@.015	SF	2.23	.69	.65	3.57
Headers and Dividers						
2" x 4", treated pine	C8@.027	LF	1.08	1.29	—	2.37
2" x 6", treated pine	C8@.028	LF	1.32	1.33	—	2.65
2" x 6", redwood	C8@.028	LF	2.13	1.33	—	3.46
2" x 4", patio type dividers, untreated	C8@.030	LF	.82	1.43	—	2.25
Porous Paving Systems Thin-walled HDPE plastic rings connected by an interlocking geogrid structure, installed on a porous base course for commercial applications. Rings transfer loads from the surface to the grid structure to an engineered course base. Equipment includes a 1/2 CY backhoe. Installed on an existing prepared base.						
Porous paving system, grass. Rolled out over base course and seeded with grass mixture. Includes fertilizer and soil polymer mix for spreading over base.						
6.6' wide by 164' long rolls	S6@.100	CSF	334.00	4.70	1.98	340.68
Add for 1" sand fill	S6@.030	CSF	9.99	1.41	—	11.40
Porous paving system, gravel. Rolled out over base course and covered with decorative fill gravel.						
6.6' wide by 164' long rolls	S6@.110	CSF	334.00	5.17	2.18	341.35
Add for 1" gravel fill	S6@.030	CSF	15.60	1.41	—	17.01
Grass-stone pavers Open diamond pattern concrete block filled with grass or aggregate laid on a compacted sand base						
24" x 16" x 3-1/2" block	CL@.085	SF	5.35	3.51	—	8.70
Guardrails and Bumpers Equipment is a 4,000 lb forklift. Use \$4,000 as a minimum job charge						
Steel guardrail, standard beam	H1@.250	LF	29.40	13.70	2.20	45.30
Posts, wood, treated, 4" x 4" x 36" high.	H1@1.00	Ea	4.30	54.90	8.81	68.01
Guardrail two sides,						
Channel rail and side blocks	H1@1.00	LF	49.80	54.90	8.81	113.51
Sight screen topper on rail	H1@.025	LF	2.56	1.37	.22	4.15
Highway median barricade, precast concrete						
2'8" high x 10' long	H1@.500	Ea	470.00	27.50	4.40	501.90
Add for reflectors, 2 per 10' section	—	LS	18.50	—	—	18.50
Parking bumper, precast concrete, including dowels						
3' wide	CL@.381	Ea	37.50	15.90	6.71	60.11
6' wide	CL@.454	Ea	66.10	18.90	8.00	93.00
Remove and reset wheel stop	CL@.908	Ea	—	37.80	16.00	53.80

32 Exterior Improvements

	Craft@Hrs	Unit	Material	Labor	Equipment	Total
Bollards Posts mounted in walkways to limit vehicle entry. Equipment is a 4,000 lb. capacity forklift. Add for concrete footings, if required, from costs shown at the end of this section. Use \$1,000 as a minimum job charge.						
Cast iron bollards, ornamental, surface mounted						
12" diameter base, 42" high	S1@1.00	Ea	1,480.00	49.70	17.60	1,547.30
17" diameter base, 42" high	S1@1.00	Ea	2,490.00	49.70	17.60	2,557.30
Lighted, electrical work not included,						
17" diameter base, 42" high	S1@1.00	Ea	2,790.00	49.70	17.60	2,857.30
Concrete bollards, precast, exposed aggregate, surface mounted						
Square, 12" x 12" x 30" high	S1@1.00	Ea	524.00	49.70	17.60	591.30
Round, 12" diameter x 30" high	S1@1.00	Ea	535.00	49.70	17.60	602.30
Granite bollards, doweled to concrete foundation or slab (foundation not included.) Costs will be higher when granite is not available locally.						
Square, smooth matte finish, flat top						
16" x 16" x 30", 756 lbs	S1@1.00	Ea	1,440.00	49.70	17.60	1,507.30
16" x 16" x 54", 1,320 lbs	S1@1.50	Ea	1,820.00	74.60	26.40	1,921.00
Square, rough finish, pyramid top						
12" x 12" x 24", 330 lbs	S1@1.00	Ea	647.00	49.70	17.60	714.30
Round, smooth matte finish, flat top						
12" diameter, 18" high	S1@1.00	Ea	1,380.00	49.70	17.60	1,447.30
Octagonal, smooth matte finish, flat top,						
24" x 24" x 20", 740 lbs	S1@1.00	Ea	2,110.00	49.70	17.60	2,177.30
Pipe bollards, concrete filled steel pipe, painted yellow, 8' long, set 4' in concrete, includes digging hole						
6" diameter pipe	S1@.750	Ea	183.00	37.30	13.20	233.50
8" diameter pipe	S1@.750	Ea	304.00	37.30	13.20	354.50
12" diameter pipe	S1@.750	Ea	493.00	37.30	13.20	543.50
Wood bollards, pressure treated timber, includes hand-digging and backfill of hole but no disposal of excess soil.						
Length shown is the portion exposed. Costs include bury to 3' depth.						
6" x 6" x 36" high	S1@.750	Ea	41.90	37.30	13.20	92.40
8" x 8" x 30" high	S1@.750	Ea	68.50	37.30	13.20	119.00
8" x 8" x 36" high	S1@.750	Ea	74.60	37.30	13.20	125.10
8" x 8" x 42" high	S1@.750	Ea	80.90	37.30	13.20	131.40
12" x 12" x 24" high	S1@.750	Ea	139.00	37.30	13.20	189.50
12" x 12" x 36" high	S1@.750	Ea	170.00	37.30	13.20	220.50
12" x 12" x 42" high	S1@.750	Ea	184.00	37.30	13.20	234.50
Footings for bollards, add if required						
Permanent concrete footing	C8@.500	Ea	45.50	23.80	—	69.30
Footing for removable bollards	C8@.500	Ea	207.00	23.80	—	230.80
Pavement Striping and Marking Use \$150 as a minimum job charge. Pavement line markings.						
Single line striping, 4" wide solid	PA@.005	LF	.14	.27	.05	.46
Single line striping, 4" wide skip	PA@.005	LF	.06	.27	.05	.38
Red curb painting	PA@.006	LF	.22	.32	.06	.60
Parking lot spaces. For estimating purposes, figure one space per 300 SF of parking pavement area.						
Single line striping,						
approximately 25 LF per space	PA@.115	Ea	3.39	6.18	1.04	10.61
Dual line striping,						
approximately 45 LF per space	PA@.175	Ea	6.10	9.41	1.58	17.09
Traffic symbols						
Arrows	PA@.250	Ea	9.24	13.40	2.25	24.89
Lettering, 2' x 8' template	PA@.500	Ea	59.30	26.90	4.51	90.71
Handicapped symbol						
One color	PA@.250	Ea	7.59	13.40	2.25	23.24
Two color	PA@.500	Ea	9.78	26.90	4.51	41.19

32 Exterior Improvements

Speed Bumps and Parking Blocks Prefabricated solid plastic, pre-drilled. Based on Super Saver Bumps or Super Saver Blocks as manufactured by The Traffic Safety Store (www.trafficsafetystore.com) Costs shown include installation hardware. Labor includes drilling holes in substrate for anchors. Available in yellow, gray, blue, white.

Speed bumps, based on quantity of 16 bumps

	Craft@Hrs	Unit	Material	Labor	Total
6' x 2" x 10" (25 lbs each)	CL@.750	Ea	99.00	31.20	130.20
10' x 2" x 10" (45 lbs each)	CL@1.00	Ea	189.00	41.70	230.70

Parking blocks, based on quantity of 25 blocks

6' x 4" x 6" (16 lbs each)	CL@.750	Ea	79.00	31.20	110.20
----------------------------	---------	----	-------	-------	--------

Traffic Signs Reflectorized steel, with a high strength "U"-channel galvanized steel pipe post 10' long set 2' into the ground. Includes digging of hole with a manual auger and backfill.

Stop, 24" x 24"	CL@1.25	Ea	122.00	52.10	174.10
Speed limit, Exit, etc., 18" x 24"	CL@1.25	Ea	158.00	52.10	210.10
Warning, 24" x 24"	CL@1.25	Ea	178.00	52.10	230.10
Yield, 30" triangle	CL@1.25	Ea	194.00	52.10	246.10
Handicapped parking, 12" x 18"	CL@1.25	Ea	108.00	52.10	160.10
Add for breakaway galvanized square sign post	—	Ea	24.30	—	24.30

	Craft@Hrs	Unit	Material	Labor	Equipment	Total
--	-----------	------	----------	-------	-----------	-------

Post Holes Drilling 2' deep by 10" to 12" diameter fence post holes. Equipment is a gasoline powered 12" auger. Costs will be higher on slopes or where access is limited. These costs do not include layout, setting of fence posts or disposal of excavated material.

Light to medium soil, laborer working with a hand auger

4 holes per hour	CL@.250	Ea	—	10.40	3.64	14.04
------------------	---------	----	---	-------	------	-------

Medium to heavy soil, laborer working with a breaking bar and hand auger

2 holes per hour	CL@.500	Ea	—	20.80	7.27	28.07
------------------	---------	----	---	-------	------	-------

Medium to heavy soil, 2 laborers working with a gas-powered auger

15 holes per hour	CL@.133	Ea	—	5.54	1.93	7.47
-------------------	---------	----	---	------	------	------

Broken rock, laborer and equipment operator working with a compressor and jackhammer

2 holes per hour	S1@1.00	Ea	—	49.70	13.80	63.50
------------------	---------	----	---	-------	-------	-------

Rock, laborer and an equipment operator working with a truck-mounted drill

12 holes per hour	S1@.166	Ea	—	8.26	5.15	13.41
-------------------	---------	----	---	------	------	-------

Fencing, Chain Link Fence, industrial grade 9 gauge 2" x 2" galvanized steel chain link fabric and framework, including 2" or 2-3/8" line posts, as indicated, set at 10' intervals, set in concrete in augured post holes and 1-5/8" top rail, tension panels at corners and abrupt grade changes. Add for gates, gate posts and corner posts as required. Equipment is a gasoline-powered 12" auger. Use \$600 as a minimum job charge. For scheduling purposes, estimate that a 2-man crew will install 125 to 130 LF of fence per 8-hour day.

4' high galvanized fence, 2" line posts	C4@.073	LF	9.96	3.16	.35	13.47
6' high galvanized fence, 2" line posts	C4@.106	LF	11.90	4.59	.51	17.00
6' high galvanized fence, 2-3/8" line posts	C4@.109	LF	13.80	4.72	.51	19.03
7' high galvanized fence, 2-3/8" line posts	C4@.127	LF	13.90	5.50	.62	20.02
8' high galvanized fence, 2-3/8" line posts	C4@.146	LF	16.40	6.33	.71	23.44
10' high galvanized fence, 2-3/8" line posts	C4@.182	LF	19.00	7.89	.88	27.77
12' high galvanized fence, 2-3/8" line posts	C4@.218	LF	22.10	9.45	1.06	32.61

32 Exterior Improvements

	Craft@Hrs	Unit	Material	Labor	Equipment	Total
Add for vertical aluminum privacy slats	C4@.016	SF	3.12	.69	—	3.81
Add for vinyl coated fabric and posts	—	%	50.0	—	—	—
Add for under 200 LF quantities	C4@.006	LF	1.34	.26	.03	1.63
Deduct for highway quantities	—	LF	-2.59	—	—	-2.59
Deduct for 11 gauge chain link fabric	—	SF	-2.43	—	—	-2.43
Deduct for "C"-section line posts	—	LF	-3.79	—	—	-3.79
Gates Driveway or walkway. 9 gauge 2" x 2" galvanized steel chain link with frame and tension bars. Costs shown are per square foot of frame area. Add for hardware and gate posts, from below.						
With 1-3/8" diameter pipe frame	C4@.025	SF	23.10	1.08	—	24.18
With 1-5/8" diameter pipe frame	C4@.025	SF	26.70	1.08	—	27.78
Gate hardware, per gate						
Walkway gate	C4@.250	Ea	10.90	10.80	—	21.70
Driveway gate	C4@.250	Ea	26.70	10.80	—	37.50
Add for vinyl-coated fabric and frame	—	SF	1.12	—	—	1.12
Corner, end or gate posts, complete, heavyweight, 2-1/2" outside diameter galvanized, with fittings and brace. Costs include 2/3 CF sack of concrete per post.						
4' high	C4@.612	Ea	53.50	26.50	2.97	82.97
5' high	C4@.668	Ea	60.10	28.90	3.24	92.24
6' high	C4@.735	Ea	63.40	31.80	3.56	98.76
7' high	C4@.800	Ea	62.60	34.70	3.88	101.18
8' high	C4@.882	Ea	82.80	38.20	4.28	125.28
10' high	C4@.962	Ea	94.10	41.70	4.66	140.46
12' high, with middle rail	C4@1.00	Ea	104.00	43.30	4.85	152.15
Add for vinyl-coated posts						
Per vertical foot	—	VLF	.73	—	—	.73
Deduct for 2" outside diameter	—	VLF	-2.02	—	—	-2.02
Barbed wire topper for galvanized chain link fence						
Single strand barbed wire	C4@.004	LF	.17	.17	—	.34
3 strands on one side, with support arm	C4@.008	LF	1.10	.35	—	1.45
3 strand on each side, with support arm	C4@.013	LF	2.18	.56	—	2.74
Double coil of 24" to 30" barbed tape	C4@.038	LF	.33	1.65	—	1.98
Baseball Backstops Galvanized 9 gauge mesh chain link backstop with 2-5/8" OD galvanized vertical end posts, 2-3/8" OD galvanized vertical back posts and 1-5/8" OD galvanized framing. Includes 4' deep overhang, 20 LF behind home plate, 16 LF on both first and third base lines, rear and wing planks 3' high and two 12' long benches. Equipment is a 4,000 lb forklift.						
Traditional, 20' H x 58' W x 14' D	S6@24.0	Ea	11,500.00	1,130.00	282.00	12,912.00
Traditional, 30' H x 68' W x 14' D	S6@24.0	Ea	16,800.00	1,130.00	282.00	18,212.00
Arched, 20' H x 62' W x 20' D	S6@44.0	Ea	13,000.00	2,070.00	516.00	15,586.00
Arched, 18' H x 62' W x 20' D	S6@44.0	Ea	12,100.00	2,070.00	516.00	14,686.00
Add for concrete footings, 12" diameter x 24" deep, includes digging by hand and spreading excavated material adjacent to hole, using fence post mix bagged concrete.						
Per footing	S6@4.00	Ea	7.05	188.00	—	195.05
Sprinkler Irrigation Systems Typical complete system costs, including PVC pipe, heads, valves, fittings, trenching and backfill. Per SF of area watered. Add 10% for irrigation systems installed in areas subject to freezing hazard. Equipment is a 55 HP pneumatic tired riding type trencher.						
Large areas using pop-up impact heads, 200 to 300 SF per head, manual system						
To 5,000 SF job	S4@.005	SF	.22	.21	.09	.52
Over 5,000 SF to 10,000 SF	S4@.004	SF	.19	.17	.07	.43
Over 10,000 SF	S4@.003	SF	.16	.12	.05	.33
Add for automatic controls	S4@.001	SF	.10	.04	.02	.16

32 Exterior Improvements

	Craft@Hrs	Unit	Material	Labor	Equipment	Total
Small areas, under 5,000 SF, spray heads						
Strip, automatic, shrub type	S4@.008	SF	.34	.33	.14	.81
Commercial type, manual	S4@.007	SF	.33	.29	.13	.75
Residential type, manual	S4@.007	SF	.32	.29	.13	.74
Add for automatic controls	S4@.001	SF	.10	.04	.02	.16
Trenching for sprinkler systems, in normal non-compacted topsoil						
Main lines with a 55 HP riding type trencher, 18" wide						
12" deep, 143 LF per hour	S1@.007	LF	—	.35	.19	.54
18" deep, 125 LF per hour	S1@.008	LF	—	.40	.22	.62
24" deep, 100 LF per hour	S1@.010	LF	—	.50	.27	.77
Lateral lines with a 20 HP riding type trencher, 12" wide						
8" deep, 200 LF per hour	S1@.005	LF	—	.25	.10	.35
12" deep, 125 LF per hour	S1@.008	LF	—	.40	.17	.57
Add for hard soil (shelf, rock field, hardpan)						
	S1@.006	LF	—	.30	.13	.43
Boring under walkways and pavement.						
To 8' wide, by hand, 8 LF per hour	CL@.125	LF	—	5.21	—	5.21
Backfill and compact trench, by hand.						
Mains, to 24" deep, 125 LF per hour	CL@.008	LF	—	.33	—	.33
Laterals, to 12" deep, 190 LF per hour	CL@.005	LF	—	.21	—	.21
	Craft@Hrs	Unit	Material	Labor		Total
Restore turf above pipe after sprinkler installation						
Replace and roll sod	CL@.019	SY	6.73	.79		7.52
Reseed by hand, cover, water and mulch	CL@.010	SY	.36	.42		.78
Connection to existing water line						
Residential or small commercial tap	CL@.939	Ea	33.10	39.10		72.20
Residential or small commercial stub	CL@.683	Ea	25.60	28.50		54.10
Medium commercial stub	CL@1.25	Ea	69.50	52.10		121.60
Atmospheric vacuum breaker						
3/4"	CL@.470	Ea	20.10	19.60		39.70
1"	CL@.500	Ea	26.90	20.80		47.70
1-1/2"	CL@.575	Ea	68.10	24.00		92.10
2"	CL@.625	Ea	118.00	26.00		144.00
Pressure type vacuum breaker, with threaded ball valves						
3/4"	CL@.700	Ea	176.00	29.20		205.20
1"	CL@.750	Ea	200.00	31.20		231.20
1-1/2"	CL@.850	Ea	481.00	35.40		516.40
2"	CL@.939	Ea	551.00	39.10		590.10
Double check valve assembly with two ball valves						
1-1/2" valve	CL@.750	Ea	418.00	31.20		449.20
2" valve	CL@.939	Ea	500.00	39.10		539.10
3" valve	CL@1.25	Ea	1,720.00	52.10		1,772.10
4" valve	CL@1.50	Ea	2,680.00	62.50		2,742.50
Reduced pressure backflow preventer with gate valves						
1" backflow preventer	CL@.750	Ea	232.00	31.20		263.20
1-1/2" backflow preventer	CL@.939	Ea	432.00	39.10		471.10
2" backflow preventer	CL@.939	Ea	486.00	39.10		525.10
3" backflow preventer	CL@1.25	Ea	1,810.00	52.10		1,862.10
4" backflow preventer	CL@1.50	Ea	2,800.00	62.50		2,862.50
6" backflow preventer	CL@1.88	Ea	3,630.00	78.30		3,708.30
Valve boxes, plastic box with plastic lid						
7" round	CL@.314	Ea	11.50	13.10		24.60
10" round	CL@.375	Ea	15.90	15.60		31.50

32 Exterior Improvements

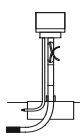
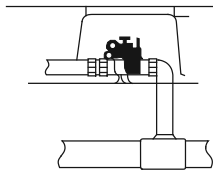
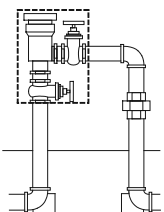
	Craft@Hrs	Unit	Material	Labor	Total
Sprinkler controllers, solid state electronics, 115-volt/24-volt electric timer, add electrical connection and feeder wire to valves					
Indoor mount, 4 station	CL@.960	Ea	26.90	40.00	66.90
Indoor mount, 6 station	CL@.960	Ea	68.70	40.00	108.70
Indoor mount, 8 station	CL@1.10	Ea	64.90	45.80	110.70
Outdoor mount, 6-8 station, PC programmable	CL@1.10	Ea	115.00	45.80	160.80
Outdoor mount, 12 station	CL@1.10	Ea	74.60	45.80	120.40
Pedestal for outdoor units, set in concrete	CL@1.00	Ea	80.10	41.70	121.80
					
Underground control wire for automatic valves, includes waterproof connectors, wire laid in an open trench, common ground, one conductor per valve					
4 conductors	CL@.001	LF	.28	.04	.32
5 conductors	CL@.001	LF	.33	.04	.37
7 conductors	CL@.002	LF	.39	.08	.47
Anti-siphon solenoid flow control valves, with atmospheric vacuum breaker. UV-resistant PVC, 24 volt. Add control wire as required.					
3/4", residential	CL@.341	Ea	16.10	14.20	30.30
1" residential	CL@.341	Ea	16.30	14.20	30.50
3/4", commercial	CL@.341	Ea	27.20	14.20	41.40
1" commercial	CL@.418	Ea	29.30	17.40	46.70
1-1/2" commercial	CL@.796	Ea	37.50	33.20	70.70
2" commercial	CL@.866	Ea	40.40	36.10	76.50
					
Manual sprinkler control valves, anti-siphon, brass, with union					
3/4" valve	CL@.518	Ea	48.30	21.60	69.90
1" valve	CL@.610	Ea	62.70	25.40	88.10
1-1/4" valve	CL@.677	Ea	98.70	28.20	126.90
1-1/2" valve	CL@.796	Ea	108.00	33.20	141.20
2" valve	CL@.866	Ea	157.00	36.10	193.10
					
Angle valves, brass, with union					
3/4" valve	CL@.518	Ea	44.00	21.60	65.60
1" valve	CL@.610	Ea	55.40	25.40	80.80
1-1/4" valve	CL@.677	Ea	121.00	28.20	149.20
1-1/2" valve	CL@.796	Ea	132.00	33.20	165.20
2" valve	CL@.866	Ea	182.00	36.10	218.10

PVC Schedule 40 pipe and fittings, except as noted. Solvent welded. Plain end. Schedule 40 denotes wall thickness. Class 315, 200 and 160 identify the normal working pressure, 315, 200 or 160 PSI. Add the cost of excavation and backfill.

1/2" pipe	CL@.005	LF	.43	.21	.64
1/2" pipe, Class 315	CL@.005	LF	.33	.21	.54
1/2" ell	CL@.120	Ea	.50	5.00	5.50
1/2" tee	CL@.140	Ea	.59	5.83	6.42
3/4" pipe	CL@.005	LF	.51	.21	.72
3/4" pipe, Class 200	CL@.005	LF	.24	.21	.45
3/4" ell	CL@.160	Ea	.65	6.67	7.32
3/4" tee	CL@.180	Ea	.77	7.50	8.27
1" pipe	CL@.006	LF	.72	.25	.97
1" pipe, Class 200	CL@.006	LF	.34	.25	.59
1" ell	CL@.180	Ea	1.26	7.50	8.76
1" tee	CL@.220	Ea	1.77	9.17	10.94
1-1/4" pipe	CL@.006	LF	1.72	.25	1.97
1-1/4" pipe, Class 160	CL@.006	LF	.60	.25	.85
1-1/4" ell	CL@.180	Ea	1.88	7.50	9.38
1-1/4" tee	CL@.250	Ea	2.64	10.40	13.04

32 Exterior Improvements

	Craft@Hrs	Unit	Material	Labor	Total
1-1/2" pipe	CL@.007	LF	1.94	.29	2.23
1-1/2" pipe, Class 160	CL@.007	LF	.77	.29	1.06
1-1/2" ell	CL@.180	Ea	2.53	7.50	10.03
1-1/2" tee	CL@.250	Ea	3.08	10.40	13.48
2" pipe	CL@.008	LF	2.54	.33	2.87
2" ell	CL@.200	Ea	3.18	8.33	11.51
2" tee	CL@.300	Ea	3.76	12.50	16.26
3" pipe	CL@.008	LF	4.75	.33	5.08
3" ell	CL@.240	Ea	12.00	10.00	22.00
3" tee	CL@.360	Ea	15.80	15.00	30.80
Polyethylene pipe, 80 PSI, black, flexible 100' rolls					
3/4" diameter	CL@.006	LF	.30	.25	.55
1" diameter	CL@.006	LF	.39	.25	.64
1-1/4" diameter	CL@.007	LF	.70	.29	.99
1-1/2" diameter	CL@.008	LF	1.01	.33	1.34
Polyethylene pipe, 100 PSI, black, flexible 100' rolls					
1-1/2" diameter	CL@.008	LF	1.02	.33	1.35
2" diameter	CL@.009	LF	1.45	.37	1.82
Add for 125 PSI polyethylene pipe	—	%	25.0	—	—
Polyethylene pipe to male iron pipe thread adapter, brass					
3/4" male adapter	CL@.112	Ea	4.81	4.67	9.48
1" male adapter	CL@.172	Ea	6.52	7.17	13.69
1-1/4" male adapter	CL@.200	Ea	9.02	8.33	17.35
Shrub and Lawn Sprinkler Heads and Risers					
Shrub bubbler, plastic nozzle, brass adjustment screw					
1/4 circle	P1@.120	Ea	1.24	4.47	5.71
1/2 circle	P1@.120	Ea	1.24	4.47	5.71
Full circle	P1@.120	Ea	.97	4.47	5.44
Mushroom spray	P1@.120	Ea	1.33	4.47	5.80
Flush head plastic lawn sprinkler, brass insert					
1/4 circle	P1@.120	Ea	1.30	4.47	5.77
1/2 circle	P1@.120	Ea	1.30	4.47	5.77
Full circle	P1@.120	Ea	1.30	4.47	5.77
Strip sprinkler	P1@.120	Ea	3.04	4.47	7.51
Brass 2" pop-up lawn sprinkler					
1/4 circle	P1@.120	Ea	3.36	4.47	7.83
1/2 circle	P1@.120	Ea	3.36	4.47	7.83
Full circle	P1@.120	Ea	3.36	4.47	7.83
Spring-loaded plastic 4" pop-up lawn sprinkler					
1/4 circle	P1@.120	Ea	3.75	4.47	8.22
1/2 circle	P1@.120	Ea	3.47	4.47	7.94
Full circle	P1@.120	Ea	3.36	4.47	7.83
Adjustable circle	P1@.120	Ea	4.26	4.47	8.73
Gear-driven rotating lawn sprinkler, 40 to 360 degrees					
15' to 30' circle	P1@.140	Ea	8.46	5.21	13.67
Pop-up impact sprinkler, adjustable, 40 to 360 degrees					
To 80' radius	P1@.140	Ea	15.50	5.21	20.71
Sprinkler riser nipples					
1/2" x close	P1@.030	Ea	.14	1.12	1.26
1/2" x 2"	P1@.030	Ea	.15	1.12	1.27
1/2" x 6" cut-off	P1@.030	Ea	.26	1.12	1.38
1/2" x 6" flexible cut-off	P1@.030	Ea	.26	1.12	1.38
1/2" x 6"	P1@.030	Ea	.28	1.12	1.40



32 Exterior Improvements

	Craft@Hrs	Unit	Material	Labor	Total
1/2" x 12"	P1@.030	Ea	.41	1.12	1.53
1/2" threaded ell	P1@.030	Ea	1.47	1.12	2.59
1/2" and 3/4" x 6" cut off	P1@.030	Ea	.77	1.12	1.89
1/2" and 3/4" x 6" flexible cut-off	P1@.030	Ea	.77	1.12	1.89
3/4" x close	P1@.030	Ea	.22	1.12	1.34
3/4" x 2"	P1@.030	Ea	.23	1.12	1.35
3/4" x 6" cut off	P1@.030	Ea	.86	1.12	1.98
3/4" x 6" flexible cut-off	P1@.030	Ea	.86	1.12	1.98
3/4" threaded ell	P1@.030	Ea	1.21	1.12	2.33
Quick coupling valves, add swing joint costs below					
3/4" regular	CL@.089	Ea	38.60	3.71	42.31
3/4" 2-piece	CL@.089	Ea	45.30	3.71	49.01
1" regular	CL@.094	Ea	53.60	3.92	57.52
1" 2-piece	CL@.094	Ea	65.60	3.92	69.52
1-1/4" regular	CL@.108	Ea	68.80	4.50	73.30
1-1/2" regular	CL@.124	Ea	83.10	5.17	88.27
Add for locking vinyl cover	—	Ea	16.70	—	16.70
Double swing sprinkler riser. Two close nipples, two PVC ells, one cut-off riser.					
1/2" pipe	P1@.150	Ea	3.48	5.58	9.06
3/4" pipe	P1@.150	Ea	3.71	5.58	9.29
Triple swing sprinkler riser. Three close nipples, three PVC ells, one cut-off riser.					
1/2" pipe	P1@.150	Ea	5.09	5.58	10.67
3/4" pipe	P1@.150	Ea	5.14	5.58	10.72
Hose bibb					
1/2" with 12" galvanized riser	CL@.041	Ea	12.60	1.71	14.31
3/4" with 12" galvanized riser	CL@.041	Ea	16.40	1.71	18.11
1/2" x 8" frost-proof with vacuum breaker	CL@.041	Ea	27.40	1.71	29.11
3/4" x 8" frost-proof with vacuum breaker	CL@.041	Ea	34.40	1.71	36.11

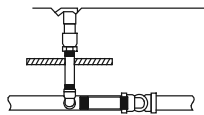

	Craft@Hrs	Unit	Material	Labor	Equipment	Total
Planting Bed Preparation						
Spreading topsoil from piles on site, based on topsoil delivered to the site. Topsoil prices can be expected to vary widely.						
Hand work, 10 CY job,						
level site, 10' throw	CL@.500	CY	25.00	20.80	—	45.80
Move 25' in wheelbarrow	CL@1.00	CY	25.00	41.70	—	66.70
With 3/4 CY loader						
100 CY job, level site	T0@.080	CY	25.00	4.62	2.60	32.22
Spreading granular or powdered soil conditioners, based on fertilizer at \$.26 per pound. Spread 20 pounds per 1,000 square feet (MSF). Add the cost of working fertilizer into the soil from below.						
By hand, 2,250 SF per hour	CL@.445	MSF	10.10	18.50	—	28.60
Hand broadcast spreader,						
9,000 SF per hour	CL@.111	MSF	10.10	4.62	.44	15.16
Push gravity spreader,						
3,000 SF per hour	CL@.333	MSF	10.10	13.90	1.91	25.91
Push broadcast spreader,						
20,000 SF per hour	CL@.050	MSF	10.10	2.08	.29	12.47
Tractor drawn broadcast spreader,						
87 MSF per hour	CL@.011	MSF	10.10	.46	.49	11.05
Spreading organic soil conditioners, based on peat humus at \$.19 per pound. Spread 200 pounds per 1,000 square feet (MSF). Add the mixing cost from below						
By hand,						
1,000 SF per hour	CL@1.00	MSF	75.70	41.70	—	117.40

32 Exterior Improvements

	Craft@Hrs	Unit	Material	Labor	Equipment	Total
Push gravity spreader, 2,750 SF per hour	CL@.363	MSF	75.70	15.10	2.09	92.89
Manure spreader, 34,000 SF per hour	CL@.029	MSF	75.70	1.21	.15	77.06
Fertilizer and soil conditioners						
Most nitrate fertilizers, ammonium sulfate	—	Lb	.32	—	—	.32
Lawn and garden fertilizer, calcium nitrate	—	Lb	.34	—	—	.34
Hydrated lime sodium nitrate	—	Lb	.27	—	—	.27
Ground limestone	—	Ton	259.00	—	—	259.00
Ground dolomitic limestone	—	Ton	267.00	—	—	267.00
Composted manure	—	Lb	.05	—	—	.05
Peat humus	—	Lb	.05	—	—	.05
Vermiculite, perlite	—	CF	9.18	—	—	9.18
Spreading lime at 70 pounds per 1,000 SF. Based on an 8 acre job using a tractor-drawn spreader at \$25.00 per hour and 1 acre per hour. Add mixing cost from below. Note: 1 acre equals 43,560 square feet.						
Lime	T0@1.00	Acre	477.00	57.30	44.10	567.00
Lime	T0@.656	Ton	274.00	37.90	29.00	340.90
Mixing soil and fertilizer in place. Medium soil. Light soil (sand or soft loam) will decrease costs shown by 20% to 30%. Heavy soil (clay, wet or rocky soil) will increase costs shown by 20% to 40%. Add soil conditioner cost from the preceding sections.						
Mixing by hand						
2" deep, 9 SY per hour	CL@.111	SY	—	4.62	—	4.62
4" deep, 7.5 SY per hour	CL@.133	SY	—	5.54	—	5.54
6" deep, 5.5 SY per hour	CL@.181	SY	—	7.54	—	7.54
Mixing with a 11 HP rear-tined hydraulic tiller						
2" deep, 110 SY per hour	CL@.009	SY	—	.37	.20	.57
4" deep, 90 SY per hour	CL@.011	SY	—	.46	.24	.70
6" deep, 65 SY per hour	CL@.015	SY	—	.62	.33	.95
8" deep, 45 SY per hour	CL@.022	SY	—	.92	.48	1.40
Mixing with a 3' wide, 20 HP tractor-driven tiller						
2" deep, 50,000 SF per hour	T0@.020	MSF	—	1.16	.66	1.82
4" deep, 40,000 SF per hour	T0@.025	MSF	—	1.44	.83	2.27
6" deep, 30,000 SF per hour	T0@.033	MSF	—	1.91	1.10	3.01
8" deep, 20,000 SF per hour	T0@.050	MSF	—	2.89	1.66	4.55
Mixing with a 6' wide, 40 HP tractor-driven tiller						
2" deep, 90,000 SF per hour	T0@.011	MSF	—	.64	.41	1.05
4" deep, 70,000 SF per hour	T0@.014	MSF	—	.81	.52	1.33
6" deep, 53,000 SF per hour	T0@.019	MSF	—	1.10	.71	1.81
8" deep, 35,000 SF per hour	T0@.028	MSF	—	1.62	1.04	2.66
Leveling the surface for lawn or planting bed						
By hand, 110 SY per hour	CL@.009	SY	—	.37	—	.37
With 6' drag harrow, at 60,000 SF per hour	T0@.017	MSF	—	.98	.62	1.60
With 12' drag harrow, at 115,000 SF per hour	T0@.009	MSF	—	.52	.48	1.00
Plant bed preparation						
With a 3/4 CY wheel loader, at 12.5 CY per hour	T0@.080	CY	—	4.62	3.60	8.22
By hand to 18" deep, 8.35 SY per hour	CL@.118	SY	—	4.92	—	4.92

32 Exterior Improvements

	Craft@Hrs	Unit	Material	Labor	Equipment	Total
Mixing planting soil						
By hand, .9 CY per hour	CL@1.11	CY	—	46.20	—	46.20
With 3/4 CY wheel loader, 7 CY per hour	T0@.143	CY	—	8.26	6.43	14.69
With a soil shredder, 11 CY per hour	T0@.090	CY	—	5.20	4.05	9.25
Seeding and Planting						
Seeding with a hand broadcast spreader, 10 pounds per 1,000 SF. The cost of grass seed will vary greatly depending on variety — see below.						
4,000 SF per hour, hand seeding	CL@.250	MSF	45.00	10.40	1.00	56.40
Seeding with push broadcast spreader, 5 pounds per 1,000 SF						
10,000 SF per hour, Push spreader seeding	CL@.100	MSF	22.50	4.17	.58	27.25
Seeding with a mechanical seeder at 175 pounds per acre, 5 acre job						
Mechanical seeding	T0@13.1	Acre	787.00	757.00	588.00	2,132.00
Mechanical seeding	T0@.300	MSF	18.10	17.30	13.50	48.90
Hydroseeding subcontract (spray application of seed, binder and fertilizer slurry). Costs will vary with access restrictions and site requirements.						
Minimum charge	—	LS	—	—	—	500.00
2,000 to 10,000 SF job	—	MSF	—	—	—	180.00
10,001 SF to 1 acre job	—	MSF	—	—	—	150.00
1 to 4.99 acre job	—	MSF	—	—	—	120.00
5 to 9.99 acre job	—	Acre	—	—	—	4,790.00
10 to 19.99 acre job	—	Acre	—	—	—	4,360.00
20 to 49.99 acre job	—	Acre	—	—	—	3,920.00
50 to 99.99 acre job	—	Acre	—	—	—	3,480.00
Over 100 acre job	—	Acre	—	—	—	3,050.00
Sealing soil, application by a hydroseeding unit. Use \$750 as a minimum job charge.						
Copolymer based liquid						
for erosion control	C4@.020	SY	1.75	.87	.22	2.84
Grass seed						
Annual ryegrass	—	Lb	3.75	—	—	3.75
Most fescue	—	Lb	2.97	—	—	2.97
Kentucky bluegrass	—	Lb	6.66	—	—	6.66
Bermuda	—	Lb	6.76	—	—	6.76
Heat-and drought-resistant premium blend	—	Lb	9.27	—	—	9.27
Dichondra	—	Lb	21.60	—	—	21.60
Centipede	—	Lb	49.60	—	—	49.60
Sodding, placed on level ground at 25 SY per hour. Add delivery cost below. Use 50 SY as a minimum job charge.						
Prices will vary by region and season.						
Bluegrass and bluegrass blends	CL@.040	SY	4.83	1.67	—	6.50
Fescue varieties	CL@.040	SY	7.30	1.67	—	8.97
Bermuda and centipedes	CL@.040	SY	7.08	1.67	—	8.75
Zoysias	CL@.040	SY	6.90	1.67	—	8.57
St. Augustine varieties	CL@.040	SY	7.18	1.67	—	8.85
Typical delivery cost, to 90 miles	—	SY	.75	—	—	.75
Add for staking sod on slopes	CL@.010	SY	.31	.42	—	.73
Deduct for 100 SY or greater jobs	—	%	-45.0	—	—	—
Work grass seed into soil, no seed included. Use \$1,500 as a minimum job charge.						
By hand, 220 SY per hour	CL@.005	SY	—	.21	—	.21
6' harrow and 40 HP tractor 60 MSF per hour	T0@.017	MSF	—	.98	1.15	2.13
12' harrow and 60 HP tractor 100 MSF per hour	T0@.010	MSF	—	.58	.54	1.12

32 Exterior Improvements

	Craft@Hrs	Unit	Material	Labor	Equipment	Total
Apply top dressing over seed or stolons.						
300 pounds per 1,000 SF (2.7 pounds per SY)						
By hand, 65 SY per hour	CL@.015	SY	.67	.62	—	1.29
With manure spreader						
10,000 SF per hour	CL@.125	MSF	74.80	5.21	—	80.01
Roll sod or soil surface with a roller.						
With a push roller, 400 SY per hour	CL@.015	SY	—	.62	—	.62
With a 20 HP tractor						
25,000 SF per hour	T0@.040	MSF	—	2.31	1.16	3.47
Sprigging, by hand.						
6" spacing, 50 SY per hour	CL@2.22	MSF	.64	92.50	—	93.14
9" spacing, 100 SY per hour	CL@1.11	MSF	.98	46.20	—	47.18
12" spacing, 150 SY per hour	CL@.778	MSF	1.30	32.40	—	33.70
Hybrid Bermuda grass stolons, Per bushel	—	Ea	3.00	—	—	3.00
Ground cover, large areas, no surface preparation						
Ice plant (80 SF per flat)	CL@.008	SF	.42	.33	—	.75
Strawberry (75 SF per flat)	CL@.008	SF	.47	.33	—	.80
Ivy and similar (70 SF per flat)	CL@.008	SF	.44	.33	—	.77
Gravel bed, pea gravel (1.4 tons per CY)						
Spread by hand	CL@.555	CY	71.50	23.10	—	94.60
Trees and shrubs						
Shrubs, most varieties						
1 gallon, 100 units	CL@.085	Ea	16.10	3.54	—	19.64
1 gallon, over 100 units	CL@.076	Ea	14.80	3.17	—	17.97
5 gallons, 100 units	CL@.443	Ea	41.70	18.50	—	60.20
Trees, most varieties, complete, staked, typical costs						
5 gallon, 4' to 6' high	CL@.716	Ea	62.20	29.80	—	92.00
15 gallon, 8' to 10' high	CL@1.37	Ea	164.00	57.10	—	221.10
20" x 24" box, 10' to 12' high	CL@4.54	Ea	857.00	189.00	—	1,046.00
Specimen size 36" box, 14' to 20' high	CL@11.6	Ea	1,770.00	483.00	—	2,253.00
Guaranteed establishment of plants						
Add, as a % of total contract price	—	%	—	—	—	12.0
Edging						
Plastic benderboard, 5" x 3/8", staked	CL@.013	LF	.87	.54	—	1.41
Redwood benderboard, 4" x 5/16",	CL@.013	LF	.43	.54	—	.97
Redwood headerboard, 2" x 4", staked						
Construction Common grade	CL@.127	LF	1.97	5.29	—	7.26
Decomposed granite edging Saturated and rolled, 3" deep	CL@.011	SF	.66	.46	—	1.12
Landscape stepping stones (concrete pavers)						
Laid on level ground, 12" x 12", 30 lb. each	CL@.024	SF	1.49	1.00	—	2.49
Pressure-treated piles, in 2' to 5' sections, 9" to 12" diameter	CL@.045	LF	5.17	1.87	—	7.04

32 Exterior Improvements

	Craft@Hrs	Unit	Material	Labor	Total
Tree Grates Two piece cast iron grates surrounding a tree trunk, set in concrete. Add for delivery.					
36" x 36" x 2-3/4" square (270 lbs.)	C4@4.00	Ea	395.00	173.00	568.00
48" x 48" x 2-3/4" square (512 lbs.)	C4@5.00	Ea	437.00	217.00	654.00
60" x 60" x 2-3/4" square (750 lbs.)	C4@6.50	Ea	492.00	282.00	774.00
36" diameter x 2-3/4" round (230 lbs.)	C4@4.00	Ea	402.00	173.00	575.00
48" diameter x 2-3/4" round (480 lbs.)	C4@5.00	Ea	464.00	217.00	681.00
Add for cast steel frame	—	%	45.0	20.0	—

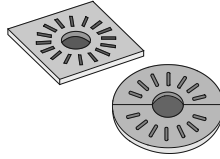

33 Utilities

	Craft@Hrs	Unit	Material	Labor	Equipment	Total
Cast Iron Flanged Pipe AWWA C151 pipe with cast iron flanges on both ends. Pipe is laid and connected in an open trench. Equipment includes a wheel-mounted 1 CY backhoe for lifting and placing the pipe and fittings. Trench excavation, dewatering, backfill and compaction are not included. Use \$3,000 as a minimum job charge. See next section for fittings, valves and accessories.						
4" pipe, 260 pounds per 18' section	U1@.057	LF	26.30	2.93	.82	30.05
6" pipe, 405 pounds per 18' section	U1@.075	LF	30.80	3.85	1.07	35.72
8" pipe, 570 pounds per 18' section	U1@.075	LF	44.00	3.85	1.07	48.92
10" pipe, 740 pounds per 18' section	U1@.094	LF	59.40	4.82	1.35	65.57
12" pipe, 930 pounds per 18' section	U1@.094	LF	80.80	4.82	1.35	86.97

Cast Iron Fittings, Valves and Accessories Based on type ASA A21, 10-A21-11-6 and 4C110-64, C111-64 fittings. Installed in an open trench and connected. Equipment includes a wheel-mounted 1 CY backhoe for lifting and placing. Trench excavation, dewatering, backfill and compaction are not included. These items are also suitable for use with the Ductile Iron Pipe in the section that follows. Costs estimated using this section may be combined with the costs estimated from the Cast Iron Flanged Pipe section or the Ductile Iron Pipe section for arriving at the minimum job charge shown in those sections.

Cast iron mechanical joint 90 degree ells						
4" ell	U1@.808	Ea	197.00	41.50	11.60	250.10
6" ell	U1@1.06	Ea	295.00	54.40	15.20	364.60
8" ell	U1@1.06	Ea	430.00	54.40	15.19	499.59
10" ell	U1@1.32	Ea	649.00	67.70	18.90	735.60
12" ell	U1@1.32	Ea	811.00	67.70	18.90	897.60
14" ell	U1@1.32	Ea	1,840.00	67.70	18.90	1,926.60
16" ell	U1@1.65	Ea	2,130.00	84.70	23.60	2,238.30
Deduct for 1/8 or 1/16 bends	—	%	-20.0	—	—	—
Cast iron mechanical joint tees						
4" x 4"	U1@1.22	Ea	305.00	62.60	17.50	385.10
6" x 4"	U1@1.59	Ea	386.00	81.60	22.80	490.40
6" x 6"	U1@1.59	Ea	421.00	81.60	22.80	525.40
8" x 8"	U1@1.59	Ea	607.00	81.60	22.80	711.40
10" x 10"	U1@1.59	Ea	882.00	81.60	22.80	986.40
12" x 12"	U1@2.48	Ea	1,140.00	127.00	35.50	1,302.50
Add for wyes	—	%	40.0	—	—	—
Add for crosses	—	%	30.0	33.0	33.0	—
Cast iron mechanical joint reducers						
6" x 4"	U1@1.06	Ea	222.00	54.40	15.20	291.60
8" x 6"	U1@1.06	Ea	332.00	54.40	15.20	401.60
10" x 8"	U1@1.32	Ea	431.00	67.70	18.90	517.60
12" x 10"	U1@1.32	Ea	580.00	67.70	18.90	666.60

33 Utilities

	Craft@Hrs	Unit	Material	Labor	Equipment	Total
AWWA mechanical joint gate valves						
3" valve	U1@3.10	Ea	593.00	159.00	44.40	796.40
4" valve	U1@4.04	Ea	839.00	207.00	57.90	1,103.90
6" valve	U1@4.80	Ea	1,330.00	246.00	68.80	1,644.80
8" valve	U1@5.14	Ea	2,280.00	264.00	73.70	2,617.70
10" valve	U1@5.67	Ea	3,560.00	291.00	81.30	3,932.30
12" valve	U1@6.19	Ea	6,060.00	318.00	88.70	6,466.70
Indicator post valve						
6" upright, adjustable	U1@6.50	Ea	941.00	334.00	93.20	1,368.20
Fire hydrant with spool						
6"	U1@5.00	Ea	1,620.00	257.00	71.70	1,948.70
Backflow preventers, installed at ground level						
3" backflow preventer	U1@3.50	Ea	2,770.00	180.00	50.20	3,000.20
4" backflow preventer	U1@4.00	Ea	3,770.00	205.00	57.30	4,032.30
6" backflow preventer	U1@5.00	Ea	6,370.00	257.00	71.70	6,698.70
8" backflow preventer	U1@6.00	Ea	8,980.00	308.00	86.00	9,374.00
Block structure for backflow preventer						
5' x 7' x 3/4"	M1@32.0	Ea	1,290.00	1,540.00	—	2,830.00
Shear gate						
8", with adjustable release handle	U1@2.44	Ea	2,250.00	125.00	35.00	2,410.00
Adjustable length valve boxes, for up to 20" valves						
5' depth	U1@1.75	Ea	207.00	89.80	25.10	321.90
Concrete thrust blocks, minimum formwork						
1/4 CY thrust block	C8@1.20	Ea	92.80	57.10	—	149.90
1/2 CY thrust block	C8@2.47	Ea	187.00	118.00	—	305.00
3/4 CY thrust block	C8@3.80	Ea	277.00	181.00	—	458.00
1 CY thrust block	C8@4.86	Ea	371.00	231.00	—	602.00
Tapping saddles, double strap, iron body, tap size to 2"						
Pipe to 4"	U1@2.38	Ea	58.90	122.00	34.10	215.00
8" pipe	U1@2.89	Ea	77.40	148.00	41.40	266.80
10" pipe	U1@3.15	Ea	79.00	162.00	45.10	286.10
12" pipe	U1@3.52	Ea	104.00	181.00	50.40	335.40
14" pipe, bronze body	U1@3.78	Ea	104.00	194.00	54.20	352.20
Tapping valves, mechanical joint						
4" valve	U1@6.93	Ea	959.00	356.00	99.30	1,414.30
6" valve	U1@8.66	Ea	1,290.00	444.00	124.00	1,858.00
8" valve	U1@9.32	Ea	1,920.00	478.00	134.00	2,532.00
10" valve	U1@10.4	Ea	2,900.00	534.00	149.00	3,583.00
12" valve	U1@11.5	Ea	4,400.00	590.00	165.00	5,155.00
Labor and equipment tapping pipe, by hole size. Add the cost of excavation and backfill.						
4" pipe	U1@5.90	Ea	—	303.00	84.60	387.60
6" pipe	U1@9.32	Ea	—	478.00	134.00	612.00
8" pipe	U1@11.7	Ea	—	600.00	168.00	768.00
10" pipe	U1@15.5	Ea	—	795.00	222.00	1,017.00
12" pipe	U1@23.4	Ea	—	1,200.00	335.00	1,535.00

33 Utilities

Craft@Hrs Unit Material Labor Equipment Total

Ductile Iron Pressure Pipe Mechanical joint 150 lb Class 50 ductile iron pipe. Installed in an open trench to 5' deep. Equipment includes a wheel-mounted 1 CY backhoe for lifting and placing the pipe. Trench excavation, dewatering, backfill and compaction are not included. Cast iron fittings and valves appear in the preceding sections. Use \$4,000 as a minimum job charge.

4" pipe	U1@.140	LF	15.60	7.18	2.01	24.79
6" pipe	U1@.180	LF	25.10	9.24	2.58	36.92
8" pipe	U1@.200	LF	31.00	10.30	2.87	44.17
10" pipe	U1@.230	LF	39.90	11.80	3.30	55.00
12" pipe	U1@.260	LF	46.30	13.30	3.73	63.33
14" pipe	U1@.300	LF	69.30	15.40	4.30	89.00
16" pipe	U1@.340	LF	73.30	17.40	4.87	95.57
18" pipe	U1@.400	LF	82.20	20.50	5.73	108.43
20" pipe	U1@.500	LF	92.20	25.70	7.17	125.07
24" pipe	U1@.600	LF	101.00	30.80	8.60	140.40

PVC Water Pipe Installed in an open trench. Equipment includes a wheel-mounted 1 CY backhoe for lifting and placing the pipe. Trench excavation, bedding material and backfill are not included. Use \$2,500 as a minimum job charge.

Class 200 PVC cold water pressure pipe, bell end, SDR 21

1-1/2" pipe	U1@.029	LF	.62	1.49	.42	2.53
2" pipe	U1@.036	LF	.93	1.85	.52	3.30
2-1/2" pipe	U1@.037	LF	1.40	1.90	.53	3.83
3" pipe	U1@.065	LF	1.97	3.34	.93	6.24
4" pipe	U1@.068	LF	3.31	3.49	.97	7.77
6" pipe	U1@.082	LF	7.22	4.21	1.18	12.61

90-degree ells Schedule 40

1-1/2" ells	P6@.385	Ea	2.37	20.40	—	22.77
2" ells	P6@.489	Ea	3.86	25.90	—	29.76
2-1/2" ells	P6@.724	Ea	11.70	38.30	—	50.00
3" ells	P6@1.32	Ea	14.00	69.80	—	83.80
4" ells	P6@1.57	Ea	24.50	83.10	—	107.60
6" ells	P6@1.79	Ea	79.50	94.70	—	174.20
Deduct for 45-degree ells	—	%	-5.0	—	—	—

Tees

1-1/2" tees	P6@.581	Ea	3.17	30.70	—	33.87
2" tees	P6@.724	Ea	4.79	38.30	—	43.09
2-1/2" tees	P6@.951	Ea	15.30	50.30	—	65.60
3" tees	P6@1.57	Ea	20.10	83.10	—	103.20
4" tees	P6@2.09	Ea	36.70	111.00	—	147.70
6" tees	P6@2.70	Ea	122.00	143.00	—	265.00

Polyethylene Pipe Belled ends with rubber ring joints. Installed in an open trench. Equipment includes a wheel-mounted 1/2 CY backhoe for lifting and placing the pipe. No excavation, bedding material, shoring, backfill or dewatering included. Use \$2,000 as a minimum job charge. SDR is Standard Dimension Ratio, comparing pipe diameter with pipe wall thickness. The smaller the first number, the higher the pressure rating.

160 PSI polyethylene pipe, SDR 11 to 1

3" pipe	U1@.108	LF	10.20	5.54	1.22	16.96
4" pipe	U1@.108	LF	16.90	5.54	1.22	23.66
5" pipe	U1@.108	LF	26.50	5.54	1.22	33.26
6" pipe	U1@.108	LF	36.70	5.54	1.22	43.46
8" pipe	U1@.145	LF	62.00	7.44	1.64	71.08
10" pipe	U1@.145	LF	97.40	7.44	1.64	106.48
12" pipe	U1@.145	LF	137.00	7.44	1.64	146.08

33 Utilities

	Craft@Hrs	Unit	Material	Labor	Equipment	Total
100 PSI polyethylene pipe, SDR 17 to 1						
4" pipe	U1@.108	LF	11.60	5.54	1.22	18.36
6" pipe	U1@.108	LF	24.70	5.54	1.22	31.46
8" pipe	U1@.145	LF	41.50	7.44	1.64	50.58
10" pipe	U1@.145	LF	64.00	7.44	1.64	73.08
12" pipe	U1@.145	LF	90.50	7.44	1.64	99.58
Low-pressure polyethylene pipe, SDR 21 to 1						
4" pipe	U1@.108	LF	9.51	5.54	1.22	16.27
5" pipe	U1@.108	LF	14.00	5.54	1.22	20.76
6" pipe	U1@.108	LF	20.80	5.54	1.22	27.56
7" pipe	U1@.145	LF	23.40	7.44	1.64	32.48
8" pipe	U1@.145	LF	34.40	7.44	1.64	43.48
10" pipe	U1@.145	LF	51.80	7.44	1.64	60.88
12" pipe	U1@.145	LF	74.90	7.44	1.64	83.98
14" pipe	U1@.169	LF	90.50	8.67	1.91	101.08
16" pipe	U1@.169	LF	119.00	8.67	1.91	129.58
18" pipe	U1@.169	LF	146.00	8.67	1.91	156.58
20" pipe	U1@.212	LF	182.00	10.90	2.40	195.30
22" pipe	U1@.212	LF	222.00	10.90	2.40	235.30
24" pipe	U1@.212	LF	264.00	10.90	2.40	277.30
Fittings, molded, bell ends						
4" 90-degree ell, 160 PSI	U1@2.00	Ea	274.00	103.00	22.60	399.60
4" 45-degree ell, 160 PSI	U1@2.00	Ea	274.00	103.00	22.60	399.60
6" 90-degree ell, 160 PSI	U1@2.00	Ea	559.00	103.00	22.60	684.60
6" 45-degree ell, 160 PSI	U1@2.00	Ea	559.00	103.00	22.60	684.60
4" to 3" reducer, 160 PSI	U1@2.00	Ea	162.00	103.00	22.60	287.60
6" to 4" reducer, 160 PSI	U1@2.00	Ea	391.00	103.00	22.60	516.60
3" transition section, 160 PSI	U1@2.00	Ea	343.00	103.00	22.60	468.60
6" transition section, 160 PSI	U1@2.00	Ea	1,540.00	103.00	22.60	1,665.60
10" by 4" branch saddle, 160 PSI	U1@3.00	Ea	496.00	154.00	33.90	683.90
3" flanged adapter, low pressure	U1@1.00	Ea	259.00	51.30	11.30	321.60
4" flanged adapter, low pressure	U1@1.00	Ea	370.00	51.30	11.30	432.60
6" flanged adapter, low pressure	U1@1.00	Ea	484.00	51.30	11.30	546.60
8" flanged adapter, low pressure	U1@1.50	Ea	701.00	77.00	17.00	795.00
10" flanged adapter, low pressure	U1@1.50	Ea	989.00	77.00	17.00	1,083.00
4" flanged adapter, 160 PSI	U1@1.00	Ea	403.00	51.30	11.30	465.60
6" flanged adapter, 160 PSI	U1@1.00	Ea	566.00	51.30	11.30	628.60
Fittings, fabricated, belled ends						
10" 90-degree ell, 100 PSI	U1@3.00	Ea	2,840.00	154.00	33.90	3,027.90
10" 45-degree ell, 100 PSI	U1@3.00	Ea	1,590.00	154.00	33.90	1,777.90
4" 30-degree ell, 100 PSI	U1@2.00	Ea	462.00	103.00	22.60	587.60
8" to 6" reducer, 100 PSI	U1@3.00	Ea	839.00	154.00	33.90	1,026.90
10" to 8" reducer, 100 PSI	U1@3.00	Ea	989.00	154.00	33.90	1,176.90
4" 45-degree wye, 100 PSI	U1@2.00	Ea	1,220.00	103.00	22.60	1,345.60
Water Main Sterilization Gas chlorination method, typical costs for sterilizing new water mains prior to inspection, includes operator and equipment. Add \$200 to total costs for setting up and removing equipment. Minimum cost will be \$500. These costs include the subcontractor's overhead and profit. Typical cost per 1,000 LF of main with diameter as shown.						
3" or 4" diameter	—	MLF	—	—	—	58.10
6" diameter	—	MLF	—	—	—	103.00
8" diameter	—	MLF	—	—	—	136.00

33 Utilities

	Craft@Hrs	Unit	Material	Labor	Equipment	Total
10" diameter	—	MLF	—	—	—	156.00
12" diameter	—	MLF	—	—	—	193.00
14" diameter	—	MLF	—	—	—	228.00
16" diameter	—	MLF	—	—	—	243.00
18" diameter	—	MLF	—	—	—	301.00
24" diameter	—	MLF	—	—	—	398.00
36" diameter	—	MLF	—	—	—	572.00
48" diameter	—	MLF	—	—	—	777.00

Water Tanks, Elevated Typical subcontract prices for 100' high steel tanks, including design, fabrication and erection. Complete tank includes 36" pipe riser with access manhole, 8" overflow to ground, ladder with protective cage, vent, balcony catwalk, concrete foundation, painting and test. No well, pump, fencing, drainage or water distribution piping included. Costs are per tank with gallon capacity as shown. Tanks built in areas without earthquake or high wind risk may cost 15% to 25% less.

	Craft@Hrs	Unit	Material	Labor	Equipment	Total
75,000 gallon	—	Ea	—	—	—	436,000.00
100,000 gallon	—	Ea	—	—	—	468,000.00
150,000 gallon	—	Ea	—	—	—	560,000.00
200,000 gallon	—	Ea	—	—	—	732,000.00
300,000 gallon	—	Ea	—	—	—	908,000.00
400,000 gallon	—	Ea	—	—	—	1,050,000.00
Add or subtract for each foot of height more or less than 100, per 100 gallons of capacity	—	Ea	—	—	—	1.05
Cathodic protection system, per tank	—	LS	—	—	—	22,200.00
Electric service, including float switches, obstruction marker lighting system, and hookup of cathodic protection system	—	LS	—	—	—	16,700.00

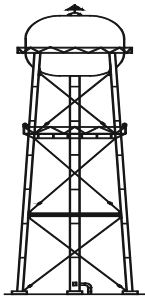

	Craft@Hrs	Unit	Material	Labor	Equipment	Total
4" pipe	C5@.047	LF	3.18	2.21	.67	6.06
6" pipe	C5@.056	LF	6.92	2.63	.80	10.35
8" pipe	C5@.061	LF	12.40	2.86	.87	16.13
10" pipe	C5@.079	LF	16.40	3.71	1.13	21.24
12" pipe	C5@.114	LF	22.80	5.35	1.63	29.78

Sewer cleaning, ball method Typical costs for cleaning new sewer mains prior to inspection, includes operator and equipment. Add \$200 to total costs for setting up and removing equipment. Minimum cost will be \$500. These costs include the subcontractor's overhead and profit. Typical costs per 1,000 LF of main diameter listed.

6" diameter	—	MLF	—	—	—	101.00
8" diameter	—	MLF	—	—	—	131.00
10" diameter	—	MLF	—	—	—	156.00
12" diameter	—	MLF	—	—	—	194.00
14" diameter	—	MLF	—	—	—	229.00
16" diameter	—	MLF	—	—	—	257.00
18" diameter	—	MLF	—	—	—	301.00
24" diameter	—	MLF	—	—	—	398.00
36" diameter	—	MLF	—	—	—	599.00
48" diameter	—	MLF	—	—	—	778.00

33 Utilities

	Craft@Hrs	Unit	Material	Labor	Equipment	Total
Sewer cleaning, jet vac Jet-Vac 2,000 psi blast to remove sediment and debris from catch basins, sanitary or storm sewers, conduit, culvert or drain pipe 6" to 36" diameter. Includes truck and operator. Time starts at the shop. Typical production rate is 400 to 500 LF per hour.						
Full 8-hour day	—	LS	—	—	—	1,790.00
Half day (4 hours)	—	LS	—	—	—	1,050.00
Addition hours	—	Ea	—	—	—	287.00
Add for debris disposal, 800 gallon load	—	LS	—	—	—	392.00
Polyethylene flexible drainage tubing Corrugated drainage tubing, plain or perforated and snap-on ABS fittings. Installed in an open trench. Excavation, bedding material and backfill not included.						
3" (10' length)	CL@.009	LF	.98	.37	—	1.35
3" (100' coil)	CL@.009	LF	.85	.37	—	1.22
4" (10' length)	CL@.011	LF	.92	.46	—	1.38
4" (100' coil)	CL@.011	LF	.71	.46	—	1.17
6" (100' coil)	CL@.014	LF	2.18	.58	—	2.76
8" (20' or 40' length)	CL@.017	LF	4.18	.71	—	4.89
10" (20' length)	CL@.021	LF	9.20	.87	—	10.07
12" (20' length)	CL@.022	LF	13.30	.92	—	14.22
Polyethylene tube snap fittings, elbows or tees						
3" fitting	CL@.025	Ea	7.98	1.04	—	9.02
4" fitting	CL@.025	Ea	9.54	1.04	—	10.58
6" fitting	CL@.025	Ea	15.90	1.04	—	16.94
Filter sock sieve. Keeps soil out of perforated pipe. Reduces need for aggregate filters. By pipe size. Per linear foot of sock.						
3", 10' length	CL@.006	LF	.56	.25	—	.81
4", 10' length	CL@.007	LF	.60	.29	—	.89
4", 100' length	CL@.007	LF	.22	.29	—	.51
Hi-Q drain pipe Corrugated high-density polyethylene drainage tubing and culvert pipe installed in an open trench. Excavation, bedding material and backfill not included. 20' lengths.						
4"	CL@.009	LF	1.67	.37	—	2.04
6"	CL@.014	LF	2.62	.58	—	3.20
12" culvert	CL@.022	LF	5.70	.92	—	6.62
15" culvert	CL@.026	LF	7.52	1.08	—	8.60
18" culvert	CL@.045	LF	9.71	1.87	—	11.58
24" culvert	CL@.090	LF	16.10	3.75	—	19.85
Corrugated drain pipe fittings						
4" snap adapter	CL@.025	Ea	5.01	1.04	—	6.05
6" snap adapter	CL@.025	Ea	13.00	1.04	—	14.04
6" x 4" reducer	CL@.025	Ea	7.94	1.04	—	8.98
6" snap coupling	CL@.025	Ea	6.21	1.04	—	7.25
6" wye	CL@.037	Ea	12.10	1.54	—	13.64
6" tee	CL@.037	Ea	22.20	1.54	—	23.74
6" blind tee	CL@.037	Ea	16.10	1.54	—	17.64
6" split end cap	CL@.025	Ea	9.51	1.04	—	10.55
12" split coupling	CL@.050	Ea	15.60	2.08	—	17.68
15" split coupling	CL@.090	Ea	20.30	3.75	—	24.05
Non-Reinforced Concrete Pipe Smooth wall, standard strength, with tongue-and-groove mortar joint ends. Installed in an open trench. Equipment includes a wheel-mounted 1 CY backhoe for lifting and placing the pipe. Trench excavation, bedding material and backfill are not included. Use \$3,500 as a minimum job charge.						
6" pipe	C5@.152	LF	6.03	7.14	2.18	15.35
8" pipe	C5@.176	LF	9.15	8.26	2.52	19.93
10" pipe	C5@.176	LF	11.90	8.26	2.52	22.68
12" pipe	C5@.186	LF	13.40	8.73	2.67	24.80

33 Utilities

	Craft@Hrs	Unit	Material	Labor	Equipment	Total
15" pipe	C5@.210	LF	18.00	9.86	3.01	30.87
18" pipe	C5@.234	LF	24.70	11.00	3.35	39.05
21" pipe	C5@.234	LF	28.60	11.00	3.35	42.95
24" pipe	C5@.260	LF	35.70	12.20	3.73	51.63
30" pipe	C5@.286	LF	58.70	13.40	4.10	76.20
Non-Reinforced Perforated Concrete Underdrain Pipe Perforated smooth wall, standard strength, 3' lengths with tongue and groove mortar joint ends. Installed in an open trench. Equipment includes a wheel-mounted 1 CY backhoe for lifting and placing the pipe. Trench excavation, bedding material and backfill are not included. Use \$2,200 as a minimum job charge.						
6" pipe	C5@.152	LF	6.74	7.14	2.18	16.06
8" pipe	C5@.208	LF	9.10	9.77	2.99	21.86
Reinforced Concrete Pipe Class III, 1350 "D"-load, ASTM C-76, 8' lengths. Tongue-and-groove mortar joint ends. Installed in an open trench. Equipment cost shown is for a wheel-mounted 1 CY backhoe for lifting and placing the pipe. Trench excavation, dewatering, backfill and compaction are not included. Use \$3,000 as a minimum job charge.						
18" pipe	C5@.272	LF	29.70	12.80	3.90	46.40
24" pipe	C5@.365	LF	44.20	17.10	5.23	66.53
30" pipe	C5@.426	LF	73.60	20.00	6.10	99.70
36" pipe	C5@.511	LF	99.70	22.90	7.32	110.36
42" pipe	C5@.567	LF	124.00	26.60	8.13	158.73
48" pipe	C5@.623	LF	162.00	29.20	8.93	200.13
54" pipe	C5@.707	LF	186.00	33.20	10.10	229.30
60" pipe	C5@.785	LF	225.00	36.90	11.30	273.20
66" pipe	C5@.914	LF	279.00	42.90	13.10	335.00
72" pipe	C5@.914	LF	316.00	42.90	13.10	372.00
78" pipe	C5@.914	LF	549.00	42.90	13.10	605.00
84" pipe	C5@1.04	LF	620.00	48.80	14.90	683.70
90" pipe	C5@1.04	LF	732.00	48.80	14.90	795.70
96" pipe	C5@1.18	LF	809.00	55.40	16.90	881.30
Reinforced Elliptical Concrete Pipe Class III, 1350 "D", C-502-72, 8' lengths, tongue-and-groove mortar joint ends. Installed in an open trench. Equipment includes a wheel-mounted 1 CY backhoe for lifting and placing the pipe. Trench excavation, dewatering, backfill and compaction are not included. Use \$3,500 as a minimum job charge.						
19" x 30" pipe, 24" pipe equivalent	C5@.356	LF	55.30	16.70	5.10	77.10
24" x 38" pipe, 30" pipe equivalent	C5@.424	LF	73.10	19.90	6.08	99.08
29" x 45" pipe, 36" pipe equivalent	C5@.516	LF	101.00	24.20	7.39	132.59
34" x 53" pipe, 42" pipe equivalent	C5@.581	LF	162.00	27.30	8.33	197.63
38" x 60" pipe, 48" pipe equivalent	C5@.637	LF	204.00	29.90	9.13	243.03
48" x 76" pipe, 60" pipe equivalent	C5@.797	LF	270.00	37.40	11.40	318.80
53" x 83" pipe, 66" pipe equivalent	C5@.923	LF	322.00	43.30	13.20	378.50
58" x 91" pipe, 72" pipe equivalent	C5@.923	LF	382.00	43.30	13.20	438.50
Flared Concrete End Sections For round concrete drain pipe, precast. Equipment includes a wheel-mounted 1 CY backhoe for lifting and placing the items. Trench excavation, dewatering, backfill and compaction are not included. Use \$2,500 as a minimum job charge.						
12" opening, 530 lbs	C5@2.41	Ea	350.00	113.00	34.50	497.50
15" opening, 740 lbs	C5@2.57	Ea	376.00	121.00	36.80	533.80
18" opening, 990 lbs	C5@3.45	Ea	417.00	162.00	49.40	628.40
24" opening, 1,520 lbs	C5@3.45	Ea	499.00	162.00	49.40	710.40
30" opening, 2,190 lbs	C5@3.96	Ea	597.00	186.00	56.80	839.80
36" opening, 4,100 lbs	C5@3.96	Ea	1,170.00	186.00	56.80	1,412.80
42" opening, 5,380 lbs	C5@4.80	Ea	1,260.00	225.00	68.80	1,553.80
48" opening, 6,550 lbs	C5@5.75	Ea	1,630.00	270.00	82.40	1,982.40
54" opening, 8,000 lbs	C5@7.10	Ea	2,710.00	333.00	102.00	3,145.00

33 Utilities

	Craft@Hrs	Unit	Material	Labor	Equipment	Total
Precast Reinforced Concrete Box Culvert Pipe ASTM C-850 with tongue-and-groove mortar joint ends. Installed in an open trench. Equipment includes a wheel-mounted 1 CY backhoe for lifting and placing the pipe. Trench excavation, dewatering, backfill and compaction are not included. Laying length is 8' for smaller cross sections and 6' or 4' for larger cross sections. Use \$8,500 as a minimum job charge.						
4' x 3'	C5@.273	LF	284.00	12.80	3.91	300.71
5' x 5'	C5@.336	LF	374.00	15.80	4.81	394.61
6' x 4'	C5@.365	LF	435.00	17.10	5.23	457.33
6' x 6'	C5@.425	LF	509.00	20.00	6.09	535.09
7' x 4'	C5@.442	LF	526.00	20.80	6.33	553.13
7' x 7'	C5@.547	LF	649.00	25.70	7.84	682.54
8' x 4'	C5@.579	LF	564.00	27.20	8.30	599.50
8' x 8'	C5@.613	LF	733.00	28.80	8.78	770.58
9' x 6'	C5@.658	LF	782.00	30.90	9.43	822.33
9' x 9'	C5@.773	LF	932.00	36.30	11.10	979.40
10' x 6'	C5@.787	LF	935.00	36.90	11.30	983.20
10' x 10'	C5@.961	LF	1,020.00	45.10	13.80	1,078.90
Corrugated Metal Pipe, Galvanized 20' lengths, installed in an open trench. Costs include couplers. Equipment includes a wheel-mounted 1 CY backhoe for lifting and placing the pipe. Trench excavation, dewatering, backfill and compaction are not included. Use \$3,500 as a minimum job charge.						
Round pipe						
8", 16 gauge (.064)	C5@.102	LF	17.60	4.79	1.46	23.85
10", 16 gauge (.064)	C5@.102	LF	18.50	4.79	1.46	24.75
12", 16 gauge (.064)	C5@.120	LF	19.20	5.63	1.72	26.55
15", 16 gauge (.064)	C5@.120	LF	23.60	5.63	1.72	30.95
18", 16 gauge (.064)	C5@.152	LF	29.00	7.14	2.18	38.32
24", 14 gauge (.079)	C5@.196	LF	44.70	9.20	2.81	56.71
30", 14 gauge (.079)	C5@.196	LF	55.20	9.20	2.81	67.21
36", 14 gauge (.079)	C5@.231	LF	67.00	10.80	3.31	81.11
42", 14 gauge (.079)	C5@.231	LF	78.10	10.80	3.31	92.21
48", 14 gauge (.079)	C5@.272	LF	88.50	12.80	3.90	105.20
60", 12 gauge (.109)	C5@.311	LF	150.00	14.60	4.46	169.06
Oval pipe						
18" x 11", 16 gauge (.064)	C5@.133	LF	28.40	6.24	1.91	36.55
22" x 13", 16 gauge (.064)	C5@.167	LF	33.90	7.84	2.39	44.13
29" x 18", 14 gauge (.079)	C5@.222	LF	52.80	10.40	3.18	66.38
36" x 22", 14 gauge (.079)	C5@.228	LF	65.50	10.70	3.27	79.47
43" x 27", 14 gauge (.079)	C5@.284	LF	70.90	13.30	4.07	88.27
Flared end sections for oval pipe						
18" x 11"	C5@1.59	Ea	153.00	74.70	22.80	250.50
22" x 13"	C5@1.75	Ea	183.00	82.20	25.10	290.30
29" x 18"	C5@1.85	Ea	277.00	86.90	26.50	390.40
36" x 22"	C5@2.38	Ea	444.00	112.00	34.10	590.10
43" x 27"	C5@2.85	Ea	735.00	134.00	40.80	909.80
Add for bituminous coating, with paved invert						
On round pipe	—	%	20.0	—	—	—
On oval pipe or flared ends	—	%	24.0	—	—	—
Deduct for aluminum pipe,						
round, oval or flared ends	—	%	-12.0	—	—	—

33 Utilities

	Craft@Hrs	Unit	Material	Labor	Equipment	Total
Corrugated Metal Nestable Pipe Split-in-half, Type I, 16 gauge. Trench excavation, backfill, compaction and grading are not included. Equipment includes a wheel-mounted 1 CY backhoe for lifting and placing the pipe. Use \$5,500 as a minimum job charge.						
12" diameter, galvanized	C5@.056	LF	32.30	2.63	.80	35.73
18" diameter, galvanized	C5@.064	LF	41.80	3.00	.92	45.72
Add for bituminous coating, with paved invert	—	%	20.0	—	—	—

Fiberglass Trench Drain System System includes 16 sloped channels, each 6 feet long, 16 channel frames, 64 iron grates, each 18 inches long, 128 grate locking bolts, outlet and end caps. Neutral channels extend the system run beyond 96 feet. Corrosion resistant polyester or vinylester. Channel has 8" internal width and built-in slope of 1%. Installed in an open trench.

	Craft@Hrs	Unit	Material	Labor	Total
Typical 96' fiberglass drainage system	P6@10.0	Ea	7,680.00	529.00	8,209.00
Typical 96' fiberglass drainage system, per LF	P6@1.04	LF	79.90	55.00	134.90
System components					
6' sloped channel	—	Ea	238.00	—	238.00
6' channel frame	—	Ea	95.40	—	95.40
18" cast iron grate	—	Ea	44.60	—	44.60
6" grate locking bolt	—	Ea	1.23	—	1.23
6" outlet cap	—	Ea	34.20	—	34.20
6" closed end cap	—	Ea	34.60	—	34.60
Add for 6' neutral channels	—	Ea	239.00	—	239.00

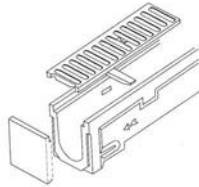

Precast Trench Drain System System includes 30 framed, interlocking tongue-and-groove connection channels, one meter long each, with integral cast-in metal rail edge, 30 snap-in galvanized steel slotted grates, 24" x 24" catch basin, 60 grate locking bolts, outlet and end caps. Channel has 4" internal width and built-in slope of .6%. All channels have preformed round and oval drillouts for vertical outlet connection with underground piping. Neutral channels extend the system run beyond 30 meters. Channel and grating combination certified to Load Class D (90,000 lbs). Installed in an open trench.

Typical 98' galvanized steel drainage system	P6@8.00	Ea	4,000.00	423.00	4,423.00
Typical 98' galvanized steel drainage system, per LF	P6@.082	LF	40.90	4.34	45.24
System components					
1 meter sloped channel with frame	—	Ea	95.30	—	95.30
1 meter galvanized steel grate	—	Ea	21.90	—	21.90
24" x 24" catch basin	—	Ea	153.00	—	153.00
Grate locking bolt	—	Ea	5.11	—	5.11
4" outlet cap	—	Ea	11.40	—	11.40
4" closed end cap	—	Ea	11.40	—	11.40
Add for 1 meter neutral channels	—	Ea	95.30	—	95.30

	Craft@Hrs	Unit	Material	Labor	Equipment	Total
Corrugated Polyethylene Culvert Pipe Heavy-duty, 20' lengths. Installed in an open trench. Equipment includes a wheel-mounted 1 CY backhoe for lifting and placing the pipe. Trench excavation, dewatering, backfill and compaction are not included. Based on 500' minimum job. Various sizes may be combined for total footage. Couplings are split type that snap onto the pipe. Use \$2,500 as a minimum job charge.						
8" diameter pipe	C5@.035	LF	4.13	1.64	.50	6.27
10" diameter pipe	C5@.038	LF	9.15	1.78	.54	11.47
12" diameter pipe	C5@.053	LF	12.90	2.49	.76	16.15
18" diameter pipe	C5@.111	LF	26.30	5.21	1.59	33.10
8" coupling	C5@.105	Ea	11.10	4.93	1.50	17.53
10" coupling	C5@.114	Ea	10.70	5.35	1.63	17.68
18" coupling	C5@.331	Ea	34.50	15.50	4.74	54.74

33 Utilities

	Craft@Hrs	Unit	Material	Labor	Equipment	Total
Vitrified Clay Pipe Extra strength, installed in open trench. 4" through 12" are 6'0" joint length, over 12" are either 7' or 7'6" joint length. Costs shown include one coupler per joint. Couplers consist of a rubber sleeve with stainless steel compression bands. Equipment includes a wheel-mounted 1 CY backhoe for lifting and placing the pipe. Trench excavation, dewatering, backfill and compaction are not included. Use \$3,500 as a minimum job charge.						
4" pipe	C5@.081	LF	2.96	3.80	1.16	7.92
6" pipe	C5@.175	LF	6.40	8.22	2.51	17.13
8" pipe	C5@.183	LF	9.24	8.59	2.62	20.45
10" pipe	C5@.203	LF	14.70	9.53	2.91	27.14
12" pipe	C5@.225	LF	20.90	10.60	3.22	34.72
15" pipe	C5@.233	LF	19.70	10.90	3.34	33.94
18" pipe	C5@.254	LF	28.50	11.90	3.64	44.04
21" pipe	C5@.283	LF	38.90	13.30	4.06	56.26
24" pipe	C5@.334	LF	51.80	15.70	4.79	72.29
27" pipe	C5@.396	LF	59.10	18.60	5.67	83.37
30" pipe	C5@.452	LF	72.00	21.20	6.48	99.68
1/4 bends including couplers						
4" bend	C5@.494	Ea	19.70	23.20	7.08	49.98
6" bend	C5@.524	Ea	34.20	24.60	7.51	66.31
8" bend	C5@.549	Ea	45.80	25.80	7.87	79.47
10" bend	C5@.610	Ea	79.10	28.60	8.74	116.44
12" bend	C5@.677	Ea	101.00	31.80	9.70	142.50
15" bend	C5@.715	Ea	267.00	33.60	9.95	310.55
18" bend	C5@.844	Ea	367.00	39.60	10.30	416.90
21" bend	C5@.993	Ea	496.00	46.60	14.23	556.83
24" bend	C5@1.17	Ea	650.00	54.90	16.80	721.70
30" bend	C5@1.37	Ea	931.00	64.30	19.60	1,014.90
Wyes and tees including couplers						
4" wye or tee	C5@.744	Ea	25.50	34.90	10.66	71.06
6" wye or tee	C5@.787	Ea	43.40	36.90	11.30	91.60
8" wye or tee	C5@.823	Ea	64.10	38.60	11.80	114.50
10" wye or tee	C5@.915	Ea	139.00	43.00	13.10	195.10
12" wye or tee	C5@1.02	Ea	182.00	47.90	14.60	244.50
15" wye or tee	C5@1.10	Ea	297.00	51.60	15.80	364.40
18" wye or tee	C5@1.30	Ea	404.00	61.00	18.60	483.60
21" wye or tee	C5@1.53	Ea	530.00	71.80	21.90	623.70
24" wye or tee	C5@1.80	Ea	631.00	84.50	25.80	741.30
27" wye or tee	C5@2.13	Ea	769.00	100.00	30.50	899.50
30" wye or tee	C5@2.50	Ea	749.00	117.00	35.80	901.80
Catch Basins Catch basin including 6" concrete top and base. Equipment includes a wheel-mounted 1 CY backhoe for lifting and placing the items. Trench excavation, bedding material and backfill are not included. Use \$3,000 as a minimum job charge.						
4' diameter precast concrete basin						
4' deep	S6@19.0	Ea	2,210.00	894.00	363.00	3,467.00
6' deep	S6@23.7	Ea	2,740.00	1,110.00	453.00	4,303.00
8' deep	S6@28.9	Ea	3,370.00	1,360.00	552.00	5,282.00
Light-duty grate, gray iron, asphalt coated						
Grate on pipe bell						
6" diameter, 13 lb	S6@.205	Ea	20.20	9.64	3.92	33.76
8" diameter, 25 lb	S6@.247	Ea	54.80	11.60	4.72	71.12
Frame and grate						
8" diameter, 55 lb	S6@.424	Ea	116.00	19.90	8.10	144.00
17" diameter, 135 lb	S6@.823	Ea	282.00	38.70	15.70	336.40

33 Utilities

	Craft@Hrs	Unit	Material	Labor	Equipment	Total
Medium-duty, frame and grate						
11" diameter, 70 lb	\$6@.441	Ea	142.00	20.70	8.43	171.13
15" diameter, 120 lb	\$6@.770	Ea	254.00	36.20	14.70	304.90
Radial grate, 20" diameter, 140 lb	\$6@1.68	Ea	291.00	79.00	32.10	402.10
Heavy-duty frame and grate						
Flat grate						
11-1/2" diameter, 85 lb	\$6@.537	Ea	183.00	25.30	10.30	218.60
20" diameter, 235 lb	\$6@2.01	Ea	497.00	94.60	38.40	630.00
21" diameter, 315 lb	\$6@2.51	Ea	608.00	118.00	48.00	774.00
24" diameter, 350 lb	\$6@2.51	Ea	673.00	118.00	48.00	839.00
30" diameter, 555 lb	\$6@4.02	Ea	987.00	189.00	76.80	1,252.80
Convex or concave grate						
20" diameter, 200 lb	\$6@1.83	Ea	352.00	86.10	35.00	473.10
20" diameter, 325 lb	\$6@2.51	Ea	577.00	118.00	48.00	743.00
Beehive grate and frame						
11" diameter, 80 lb	\$6@.495	Ea	254.00	23.30	9.46	286.76
15" diameter, 120 lb	\$6@1.83	Ea	241.00	86.10	35.00	362.10
21" diameter, 285 lb	\$6@2.51	Ea	505.00	118.00	48.00	671.00
24" diameter, 375 lb	\$6@2.87	Ea	703.00	135.00	54.80	892.80
Manholes Equipment includes a wheel-mounted 1 CY backhoe for lifting and placing the items. Trench excavation, bedding material and backfill are not included. Use \$3,000 as a minimum job charge. Precast concrete manholes, including concrete top and base. No excavation or backfill included. Add for steps, frames and lids from the costs listed below						
3' x 6' to 8' deep	\$6@17.5	Ea	2,580.00	823.00	334.00	3,737.00
3' x 9' to 12' deep	\$6@19.4	Ea	3,020.00	913.00	371.00	4,304.00
3' x 13' to 16' deep	\$6@23.1	Ea	3,890.00	1,090.00	441.00	5,421.00
3' diameter, 4' deep	\$6@12.1	Ea	1,520.00	569.00	232.00	2,321.00
4' diameter, 5' deep	\$6@22.8	Ea	1,840.00	1,070.00	435.00	3,345.00
4' diameter, 6' deep	\$6@26.3	Ea	2,080.00	1,240.00	503.00	3,823.00
4' diameter, 7' deep	\$6@30.3	Ea	2,260.00	1,430.00	578.00	4,268.00
4' diameter, 8' deep	\$6@33.7	Ea	2,540.00	1,590.00	644.00	4,774.00
4' diameter, 9' deep	\$6@38.2	Ea	2,700.00	1,800.00	730.00	5,230.00
4' diameter, 10' deep	\$6@43.3	Ea	2,950.00	2,040.00	827.00	5,817.00
Concrete block radial manholes, 4' inside diameter, no excavation or backfill included						
4' deep	M1@8.01	Ea	614.00	386.00	—	1,000.00
6' deep	M1@13.4	Ea	902.00	646.00	—	1,548.00
8' deep	M1@20.0	Ea	1,300.00	964.00	—	2,264.00
10' deep	M1@26.7	Ea	1,350.00	1,290.00	—	2,640.00
Depth over 10', add per LF	M1@2.29	LF	168.00	110.00	—	278.00
2' depth cone block for 30" grate	M1@5.34	LF	257.00	257.00	—	514.00
2'6" depth cone block for 24" grate	M1@6.43	LF	333.00	310.00	—	643.00
Manhole steps, cast iron, heavy type, asphalt coated						
10" x 14-1/2" in job-built manhole	M1@.254	Ea	29.10	12.20	—	41.30
12" x 10" in precast manhole	—	Ea	26.70	—	—	26.70
Gray iron manhole frames, asphalt coated, standard sizes						
Light-duty frame and lid						
15" diameter, 65 lb	\$6@.660	Ea	151.00	31.00	12.60	194.60
22" diameter, 140 lb	\$6@1.42	Ea	333.00	66.80	27.10	426.90
Medium-duty frame and lid						
11" diameter, 75 lb	\$6@1.51	Ea	178.00	71.00	28.90	277.90
20" diameter, 185 lb	\$6@3.01	Ea	406.00	142.00	57.50	605.50

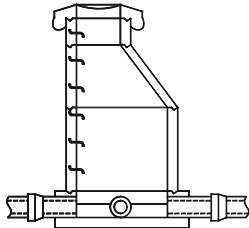

33 Utilities

	Craft@Hrs	Unit	Material	Labor	Equipment	Total
Heavy-duty frame and lid						
17" diameter, 135 lb	S6@2.51	Ea	310.00	118.00	48.00	476.00
21" diameter, 315 lb	S6@3.77	Ea	687.00	177.00	72.00	936.00
24" diameter, 375 lb	S6@4.30	Ea	796.00	202.00	82.10	1,080.10
Connect new drain line to existing manhole, no excavation or backfill included.						
Per connection	S6@6.83	Ea	235.00	321.00	131.00	687.00
Connect existing drain line to new manhole, no excavation or backfill included.						
Per connection	S6@3.54	Ea	142.00	167.00	67.60	376.60
Manhole repairs and alterations, typical costs						
Repair manhole leak with grout	S6@15.8	Ea	660.00	743.00	302.00	1,705.00
Repair inlet leak with grout	S6@15.8	Ea	802.00	743.00	302.00	1,847.00
Grout under manhole frame	S6@1.29	Ea	13.70	60.70	24.60	99.00
Drill and grout pump setup cost	S6@17.4	LS	802.00	818.00	333.00	1,953.00
Grout for pressure grouting	—	Gal	13.60	—	—	13.60
Replace brick in manhole wall	M1@8.79	SF	19.70	424.00	—	443.70
Replace brick under manhole frame	M1@8.79	LS	65.20	424.00	—	489.20
Raise existing frame and cover 2"	CL@4.76	LS	361.00	198.00	—	559.00
Raise existing frame and cover more than 2", per each 1" added	CL@.250	LS	124.00	10.40	—	134.40
Grouting concrete pipe joints						
6" to 30" diameter	S6@.315	Ea	33.10	14.80	6.02	53.92
33" to 60" diameter	S6@1.12	Ea	65.10	52.70	21.40	139.20
66" to 72" diameter	S6@2.05	Ea	133.00	96.40	39.20	268.60
TV inspection of pipe interior , Robotic crawl camera inspecting 6" to 36" pipe. Report includes a DVD or VHS images and a plot of obstructions. Equipment is a video truck with operator. Time starts at the yard.						
Full 8-hour day	—	LS	—	—	—	1,460.00
Half day (4 hours)	—	LS	—	—	—	838.00
Addition hours	—	Ea	—	—	—	229.00
Pipe locator (2 hour minimum)	—	Hr	—	—	—	158.00
Accessories for Site Utilities Equipment includes a wheel-mounted 1 CY backhoe for lifting and placing the items. Trench excavation, bedding material and backfill are not included. Costs estimated using this section may be combined with costs estimated from other site work utility sections for arriving at a minimum job charge.						
Curb inlets, gray iron, asphalt coated, heavy-duty frame, grate and precast curb box						
20" x 11", 260 lb	S6@2.75	Ea	548.00	129.00	52.50	729.50
20" x 16.5", 300 lb	S6@3.04	Ea	596.00	143.00	58.10	797.10
20" x 17", 400 lb	S6@4.30	Ea	754.00	202.00	82.20	1,038.20
19" x 18", 500 lb	S6@5.06	Ea	904.00	238.00	96.70	1,238.70
30" x 17", 600 lb	S6@6.04	Ea	978.00	284.00	115.00	1,377.00
Gutter inlets, gray iron, asphalt coated, heavy-duty frame and grate						
8" x 11.5", 85 lb	S6@.444	Ea	183.00	20.90	8.48	212.38
22" x 17", 260 lb, concave	S6@1.84	Ea	524.00	86.60	35.20	645.80
22.3" x 22.3", 475 lb	S6@2.87	Ea	569.00	135.00	54.80	758.80
29.8" x 17.8", 750 lb	S6@3.37	Ea	872.00	159.00	64.40	1,095.40
Trench inlets, ductile iron, light-duty frame and grate for pedestrian traffic						
53.5" x 8.3", 100 lb	S6@.495	Ea	179.00	23.30	9.46	211.76
Trench inlets, gray iron, asphalt coated frame and grate or solid cover						
Light-duty, 1-1/4"						
8" wide grate	S6@.247	LF	75.40	11.60	4.72	91.72
12" wide grate	S6@.275	LF	108.00	12.90	5.25	126.15
8" wide solid cover	S6@.247	LF	83.70	11.60	4.72	100.02
12" wide solid cover	S6@.275	LF	118.00	12.90	5.25	136.15

33 Utilities

	Craft@Hrs	Unit	Material	Labor	Equipment	Total
Heavy-duty, 1-3/4"						
8" wide grate	\$6@.275	LF	81.90	12.90	5.25	100.05
12" wide grate	\$6@.309	LF	120.00	14.50	5.90	140.40
8" wide solid cover	\$6@.275	LF	94.60	12.90	5.25	112.75
12" wide solid cover	\$6@.309	LF	130.00	14.50	5.90	150.40
Concrete headwalls By culvert drain pipe size. With 30-degree skewed wingwall. Add the cost of excavation, backfill and compaction.						
Cast in place concrete headwalls.						
12" pipe	P9@3.50	Ea	666.00	172.00	—	838.00
15" pipe	P9@3.80	Ea	489.00	186.00	—	675.00
18" pipe	P9@4.00	Ea	1,020.00	196.00	—	1,216.00
24" pipe	P9@4.50	Ea	1,510.00	221.00	—	1,731.00
30" pipe	P9@5.00	Ea	1,770.00	245.00	—	2,015.00
36" pipe	P9@7.50	Ea	2,000.00	368.00	—	2,368.00
42" pipe	P9@7.80	Ea	2,450.00	382.00	—	2,832.00
48" pipe	P9@9.90	Ea	2,570.00	485.00	—	3,055.00
54" pipe	P9@14.0	Ea	2,720.00	686.00	—	3,406.00
60" pipe	P9@15.5	Ea	3,540.00	760.00	—	4,300.00
Precast concrete headwalls, placed with a 1.38 CY wheel-loader backhoe						
12" pipe	\$6@8.00	Ea	396.00	376.00	17.10	789.10
15" pipe	\$6@8.00	Ea	396.00	376.00	17.10	789.10
18" pipe	\$6@9.60	Ea	396.00	452.00	20.80	868.80
24" pipe	\$6@9.60	Ea	480.00	452.00	20.80	952.80
30" pipe	\$6@12.0	Ea	732.00	564.00	26.00	1,322.00
36" pipe	\$6@12.0	Ea	732.00	564.00	26.00	1,322.00
Gas Distribution Lines Installed in an open trench. Equipment includes a wheel-mounted 1 CY backhoe for lifting and placing the pipe. No excavation, bedding material or backfill included. Use \$2,000 as a minimum job charge.						
Polyethylene pipe, 60 PSI						
1-1/4" diameter, coils	U1@.064	LF	2.92	3.28	.92	7.12
1-1/2" diameter, coils	U1@.064	LF	2.11	3.28	.92	6.31
2" diameter, coils	U1@.071	LF	5.54	3.64	1.02	10.20
3" diameter, coils	U1@.086	LF	5.31	4.41	1.23	10.95
3" diameter, 38' long with couplings	U1@.133	LF	6.57	6.83	1.91	15.31
4" diameter, 38' long with couplings	U1@.168	LF	11.70	8.62	2.41	22.73
6" diameter, 38' long with couplings	U1@.182	LF	40.50	9.34	2.61	52.45
8" diameter, 38' long with couplings	U1@.218	LF	48.80	11.20	3.12	63.12
Meters and pressure regulators Natural gas diaphragm meters, direct digital reading, not including temperature and pressure compensation. For use with pressure regulators below.						
425 CFH at 10 PSI	P6@4.38	Ea	362.00	232.00	—	594.00
425 CFH at 25 PSI	P6@4.38	Ea	479.00	232.00	—	711.00
Natural gas pressure regulators with screwed connections						
3/4" or 1" connection	P6@.772	Ea	36.90	40.80	—	77.70
1-1/4" or 1-1/2" connection	P6@1.04	Ea	196.00	55.00	—	251.00
2" connection	P6@1.55	Ea	1,610.00	82.00	—	1,692.00
Pipe Jacking Typical costs for jacking .50" thick wall pipe casing under an existing roadway. Costs assume casing is left in place. Add 15% when ground water is present. Add 100% for light rock conditions. Includes jacking pits on both sides. Equipment includes a 1 CY wheel-mounted backhoe plus a 2-ton truck equipped for this type of work. Size shown is casing diameter. Use \$2,200 as a minimum job charge.						
2" casing	C5@.289	LF	10.00	13.60	6.36	29.96
3" casing	C5@.351	LF	11.80	16.50	7.72	36.02
4" casing	C5@.477	LF	15.50	22.40	10.50	48.40
6" casing	C5@.623	LF	20.00	29.20	13.70	62.90

33 Utilities

	Craft@Hrs	Unit	Material	Labor	Equipment	Total
8" casing	C5@.847	LF	26.70	39.80	18.60	85.10
10" casing	C5@1.24	LF	39.20	58.20	27.30	124.70
12" casing	C5@1.49	LF	47.30	70.00	32.80	150.10
16" casing	C5@1.78	LF	56.30	83.60	39.20	179.10
17" casing	C5@2.09	LF	64.70	98.10	46.00	208.80
24" casing	C5@7.27	LF	230.00	341.00	160.00	731.00
30" casing	C5@7.88	LF	247.00	370.00	173.00	790.00
36" casing	C5@8.61	LF	275.00	404.00	190.00	869.00
42" casing	C5@9.29	LF	290.00	436.00	204.00	930.00
48" casing	C5@10.2	LF	320.00	479.00	225.00	1,024.00

Index

A	
Abbreviations	6
Abrasion testing	314
Abrasive	
anti-skid strip.....	283
concrete finish.....	356
stair treads	220, 432
terrazzo	433
ABS	
bungalow fitting	514
bushing	516
cap	516
cleanout adapter.....	516
cleanout tee	515
closet flange.....	515
coupling.....	513
double sanitary tee	514
double wye.....	514
elbow.....	513
female adapter.....	515
floor drains	516
male adapter.....	515
P-trap	516
return bend	516
sanitary tee.....	514
soil pipe adapter.....	516
test cap	515
test tee	515
trap adapter	516
wye	514
ABS-DWV pipe	512
cleanout plug.....	516
Absorption testing.....	314
Accent lights, LED.....	584
Access	
control units	590
disabled persons	476
fitting, PVC	550
flooring	434
handicapped.....	476
hatches, sheet metal	266
stairs, folding	284
Access doors	
attic	266
foundation	291
louver	253, 525
plumbing	253, 525
sheet metal	266
steel.....	418
tub	266
wall	266
Access points, wireless....	130, 460
Access ramps	476
Accessories	
glass block.....	217
water heater	526
Accordion	
doors.....	417
Accordion folding doors	443
Accordion folding partitions	443
Acetone	238
Acid cleaning	
concrete.....	356
etching	466
masonry.....	371
wash.....	371
Acid etching	437
Acid-proof brick.....	375
Acid-resistant countertops.....	473
Acoustical	
adhesive.....	18
block	380
ceiling panels.....	81
design fees	134
engineering	134
partitions	443
privacy testing.....	134
tile, demolition.....	100, 336
ACQ-compatible flashing ...	268, 270
ACQ-treated lumber	201
Acrovyn wall cover	444
Acrylic	
clear panels	80
diffusers	80, 583
latex caulk	77
tub and shower.....	533
waterproofing.....	184
Acrylic-urethane foam roof.....	401
Actuating devices,	
garage doors	164
ACZA treatment, lumber	206
ADA	
handicapped access	476
signage	442
Adapters	
ABS cleanout	516
ABS female	515
ABS male	515
ABS soil pipe	516
ABS trap.....	516
copper.....	504
CPVC.....	508
drain pipe	126
DWV trap.....	512
polyethylene pipe.....	621
Additives	
coloring	85, 218, 350, 356
concrete	85, 350, 356
Add-on boiler modules	578
Address systems, public.....	592
Adhesives	17
acoustical ceiling tile.....	429
ceramic tile.....	18, 428
flooring	18, 154, 159
modified bitumen	258
permanent bond	258
roofing	256, 258
tile.....	288, 289
wallpaper.....	293
wood flooring.....	159
Administrative overhead	208
Admixtures	
coloring	85, 218, 356
concrete	85, 350, 356
Adobe block.....	216
Aerators, rental.....	327
Aerial	
equipment rental.....	324
mapping.....	313
photographs	313
platform rental.....	324
Aggregate.....	18, 94
base	84
exposed, concrete	615
finish	356
paving	609
pea gravel	18
roofing	256
sand	18
seeded	244
testing	314
Air compressor	
rental	139, 320
service station	449
Air conditioning	180
heat pump.....	178
residential.....	180
window.....	177
wiring.....	128
Air curtain heaters	536
Air curtains	417
Air eliminator vent.....	538
Air eliminator-purger.....	173
Air exhausters	
exhaust hood	455
fans	142, 407
Air filter system, central.....	176
Air hammer.....	596
Air handler, residential	179
Air hose	
reel	449
rental	320
Air tool operator wage.....	309
Air tools	
earthwork	138
pneumatic	103
rental	320
Airless paint sprayer.....	239
Alarm	
access.....	434
circuit.....	542
systems.....	589, 591
systems, electrical work.....	128
valves	492
wiring.....	128, 264
Alarms	
fire	264
security.....	264
smoke	264
smoke	238
Aliphatic resin glue.....	18
All-season storm doors.....	114
Altars	462
Aluminum	
blinds	296
brakes, rental	329
cladding	400
coating	257
concrete-embedded	482
conduit	552
cupola roof.....	97
curtain wall.....	419
downspouts	404
fence	149
flagpoles	448
flashing.....	267, 403
foil insulation.....	183
gutters	404
letters	441
louvers.....	80
metal work.....	388
ornamental.....	388
oxide.....	356
patio doors.....	121
pet doors.....	122
railing.....	386
roofing.....	400
sheet	403
siding	276, 400
stairs.....	282
tile.....	429
vents.....	406
Americans with	
Disabilities (ADA access).....	476
Ammeter	571
Ammonium sulfate	623
Anchor bolts	58
foundation.....	159, 361
templates	340
tilt-up	361, 363
Anchors	
chimney.....	151
concrete.....	159
conduit hanger.....	554
embedded steel.....	373
foundation	58
masonry	372, 556
timber connectors.....	159
Andersen	121
Andersen windows.....	120
Angle	
bracket	516
clips.....	159
flashing.....	268
iron	219
iron, fireplace	151
sill, steel	387
stops	522
supports, pipe.....	517
valves	522
Annunciator panel	591
Anodizing	387
Antenna	
cable	130
remote high gain.....	130
Anti-siphon vacuum breakers ...	173
Anti-skid strips.....	283
Appliance dolly, rental.....	329
Appliances	
cabinets	31
connections	252
dishwashers.....	248
garbage disposers.....	248
ranges	255
rough-in.....	252
solar water heaters	249
water heaters	249
water softeners	250
wiring.....	128
Appraisal fees	18
Apprentice costs	3
Apron	
concrete driveway.....	615
window	53
Arbitration	
fees	19
mobile	20
Archaid	188
Archbead.....	188, 426
Architectural	
drawings	20, 126
form lining	341
screens	388, 406
shingles	258
signage	441
Area lighting	588
Area modification factors	12–15
how to use	4
Area walls, sheet metal.....	267
Arks, church	460
Armed guard	265
Armstrong	
ceiling tile	429
flooring	153, 154
Arquati Roma awnings.....	471
Arrow board, rental	326
Art glass, ecclesiastical.....	470
Asbestos	
containment	338
pipe insulation removal.....	338
removal	338
testing	26

Asbestos worker, wage.....	309	Auditorium		Barrier tapes.....	318	rough-in.....	531
As-built drawings.....	126	acoustic design fees.....	134	Barrier, egress.....	487	seat.....	25
Ash		seating.....	474	Bars		walk-in.....	246
drop.....	151	Auger holes		bath accessories.....	24	whirlpool tub.....	245
dumps.....	151	caissons.....	608	masonry.....	346, 372	Battens, lumber.....	222
flooring.....	155	post holes.....	617	reinforcing steel.....	89, 346	Batterboards.....	189
urns.....	473	Augers		welding.....	348	Batts, insulation.....	181, 397
Ash wood flooring.....	155, 158	rental.....	327	Base		Bay vent channel.....	292
Ashtray.....	473	toilet, rental.....	328	asphalt.....	243	Bay window.....	299
Asphalt		Auto hoist.....	450	ceramic tile.....	290, 374, 428	roof cover.....	304
access road.....	610	Automatic gates.....	165	column.....	387	Bead	
built-up roofing.....	256	Awning		course, paving.....	243	lath.....	426
coatings.....	256	roll-up.....	21	floor.....	154	lath & plaster.....	188
cold milling.....	611	Awning windows		hardwood.....	222	molding.....	223, 226
curb.....	610	aluminum.....	302	marble.....	381	Beadex.....	169
dampproofing.....	397	vinyl-clad wood.....	300	MDF.....	226	Beam clamps, piping.....	517
emulsion.....	381	Awnings.....	21	post.....	162	Beams	
felt.....	27, 401	canopy-type.....	472	resilient flooring.....	154	applied.....	54
milling.....	611	commercial.....	471	screed.....	188, 426	carpentry.....	390
mix.....	82	fabric.....	21	sheet, fiberglass.....	257, 258	ceiling.....	45
paper.....	258	lean-to type.....	471	slab.....	94	clamps, conduit.....	554
parking lot.....	610	motorized.....	471	Base wages		collar.....	48
paving.....	243, 609			industrial & commercial.....	309	concrete.....	339, 345
paving, demolition.....	102			residential.....	10	formwork.....	339, 345
primer.....	466			Baseball backstops.....	618	grade.....	93
recycling.....	332			Baseboard.....	55	laminated timbers.....	396
repair.....	611			bamboo.....	157	log.....	193
roll sheathing.....	27			MDF.....	226	lumber.....	201
roof coating.....	237			Baseboard heating		LVL.....	396
roofing.....	257			electric.....	536	precast.....	359
sawing.....	371			radiation.....	537	ridge.....	193
sheathing.....	182			radiators.....	175	shoring.....	345
slurry seal.....	611			Basement		steel.....	383
speed bumps.....	610			doors.....	23	steel collar.....	72
tack coat.....	610			stairs.....	281	Bearing capacity test.....	279
walks.....	615			storm window.....	304	Bearing ratio, soil testing.....	317
waterproofing.....	397			window.....	301	Bed bumpers.....	444
Asphalt cutters, rental.....	320			Basic wage cost.....	3	Bed molding.....	224, 226
Asphalt-fiberglass shingles.....	258			Basketweave fence.....	147	Beds, concealed.....	25
Asphaltic concrete testing.....	315			Basswood blinds.....	296	Beehive climber.....	467
Assemblies				Bath accessories.....	445	Beehive grate.....	636
brick wall.....	209, 373			ceramic.....	288	Bell footings.....	609
ceiling.....	36			ceramic tile.....	289	Bell wire.....	105
floor.....	33			compartments.....	442, 533	Bell wiring, electrical work.....	128
floor slab.....	352			enclosures.....	272	Bells	
framing, door opening.....	43			fans.....	142	door.....	105
framing, window openings.....	44, 66			shower cabinets.....	533	fire alarm.....	591
interior walls.....	34			shower doors.....	271	Belt conveyors.....	491
plumbing.....	530, 532			vanities.....	290	Benches	
ramps, landings,				Bath exhaust fan.....	139, 140	athletic.....	466
for handicapped.....	476			accessories.....	141	bus stop.....	479
roof.....	36			ceiling blower.....	139	church.....	460
roofing.....	37			Exhaust Air.....	140	locker room.....	474
steel framing, door opening.....	65			Heat-A-Lamp.....	141	park.....	474
steel framing, window opening.....	66			heater, ceiling.....	141	stadium.....	474
wall.....	34			QuietTest.....	140	Benderboard.....	187
wall, brick.....	209, 373			switch.....	141	Benefits, fringe.....	309
Astragal molding.....				timer switch.....	141	Bentonite	
.....	108, 223, 413, 421			ValueTest.....	140	granules.....	355
Astro dial time switch.....	564			vent kit.....	141	waterproofing.....	294
Athletic				with heater.....	141	Bevel siding.....	199
benches.....	466			with heater, infrared.....	140	Beveled glass doors.....	107
court, striping.....	467			with light.....	140	Beverage dispenser.....	458
court, surface prep.....	466			Bath fixtures.....	531, 533	Bicycle racks.....	475
equipment.....	465			Bathroom		Bidets.....	247
equipment, swimming pools.....	475			accessories.....	23	Bi-fold doors.....	124, 125
field marker.....	218			cabinets.....	290	hardware.....	125
fields.....	465			fan wiring.....	128	mirrored.....	125
gym equipment.....	464			fans.....	139, 140, 141	Bike post bollard.....	475
ATM machine.....	453			sinks.....	247, 533	Bin, trash.....	332
Attachments, crane, rental.....	322			vanities.....	290	Birch	
Attic				wallboard.....	168	doors.....	115, 116
access doors.....	266			Baths, steam.....	285	paneling.....	242
fans.....	128			Bathtubs.....	245, 531, 533	plywood.....	203
fans, belt drive.....	141			ADA compliant.....	246	Bird screen.....	406
gable vents.....	142			caulk.....	78	Birdstop.....	262
stairs, folding.....	284			doors.....	271	Bitumen adhesive, modified.....	258
vents.....	291			enameled cast iron.....	245	Bituminous	
Audio				enameled steel.....	245	paving.....	243, 611
detectors.....	264			fiberglass.....	245	paving, removal.....	332
sensors.....	589			recessed.....	245	roofing.....	256, 401
Audio-visual equipment,							
school.....	458						

Black steel pipe.....	494	roofing.....	256, 402	Bricklayer, wage		Bus schedule, display panel....	480
Blanket insulation.....	183	Bonds, insurance.....	185	industrial & commercial.....	309	Bus stop	
Blasting		Bookcases, painting.....	241	residential.....	10	enclosures.....	479
excavation.....	595	Boomlifts, rental.....	324	Bricklayer's helper, wage		shelters.....	479
sand.....	371	Boring		residential.....	10	Bushings	
water.....	239, 263, 333, 371, 437	caissons.....	608	Bridge, pedestrian.....	487	ABS.....	516
Bleachers.....	464, 474	soil testing.....	279	Bridging		conduit.....	543
Blinds		under walkways.....	619	carpentry.....	41	Business overhead.....	208
aluminum.....	296	Bottom plates, carpentry.....	37	I-Joist.....	160	Butacite.....	482
cellular.....	297	Bottom track, steel framing.....	73	joist.....	159, 390	Butt hinges.....	420
PVC.....	296	Bow windows.....	304	steel floor joists.....	61	Button board.....	187
roll-up.....	296	Box nails.....	227	tension.....	159	Button switches.....	565
Venetian.....	296	Boxes		Broan Manufacturing... 140, 141, 255		Buttweld joints, welding.....	389
vertical.....	296	electrical.....	561	Broiler, food.....	455	Butyl roof coating.....	402
Block		junction.....	563	Bronze fabrications.....	388	Butyl roofing.....	401
adobe.....	216	outlet.....	128, 561	Broom finish, concrete.....	95, 356	BX cable.....	560
concrete.....	213, 378	pull.....	562	Brown coat plaster.....	244, 427	Bypass doors.....	123
core fill.....	213, 378	switch.....	128	Brush		accessories.....	124
demolition.....	335	valve.....	619	chippers, rental.....	327	beveled mirror.....	123
detailed concrete.....	213, 378	Braces		cutters, rental.....	327	mirrored.....	123, 124
filler, acrylic.....	237	tilt-up.....	363	hogs, rental.....	327		
flooring.....	158	trench, rental.....	323	removal.....	137, 594		
glass building.....	217	wall.....	164	Brush finish, concrete.....	95		
masonry.....	213, 378	Bracing		Brush painting.....	436		
painting.....	240, 438	bulkheads.....	605	Bucket truck			
pier.....	39	carpentry.....	44, 390	rental.....	324	Cabinets	
sawing.....	370	steel framing.....	67	Bucket, clamshell, rental.....	322	bath.....	220, 290, 446
walls, concrete.....	213	temporary.....	44, 67	Buckets, rental.....	321	classroom.....	473
Block filler, painting.....	438	trenches.....	605	Buggies, rental.....	321	cleaning.....	83
Blocking		trenches, rental.....	323	Builder's adhesive.....	17	custom.....	472
carpentry.....	389	Brads, nails.....	229	Builder's hardware.....	421	end panels.....	31
finish carpentry.....	51	Braille signage.....	442	rough carpentry.....	159	extinguisher.....	493
fireblocks.....	45	elevator.....	479	Building		finish carpentry.....	473
sheathing.....	392	Branch circuits.....	573	appraisal.....	18	fire hose.....	493
steel floor joists.....	61	Brass		blocks, concrete filled.....	87	hardware.....	420, 472
Blockout forms		fabrications.....	388	board.....	293, 398	hospital.....	473
cast-in-place slabs.....	341	railing.....	386	columns.....	186	installation.....	55
tilt-up.....	361	storm.....	114	demolition.....	103, 334	kitchen.....	29
Blockouts, concrete.....	342	Bread slicer.....	456	hardware.....	421	labor cost.....	31
Blood storage refrigerators.....	469	Breaker		moving.....	338	laboratory.....	473
Blowers		bond.....	355	paper.....	27, 28	lavatory.....	290
exhaust hood.....	455	circuit.....	128	permit fees.....	28	lighting fixtures.....	191, 221
fans.....	142	form.....	355	posts, steel.....	186	linen, shelving.....	270
fireplace.....	152	panels.....	571, 572	sewer.....	266	medicine.....	220, 290, 446
heating.....	535	paving, rental.....	320	stone, testing.....	316	metal.....	472
Blown-in insulation.....	183, 398	vacuum.....	312, 618	wiring.....	127	painting.....	241
Blue Board insulation.....	181	Breaking, demolition.....	104, 334	Building laborer, wage		shelving.....	270
Bluegrass seeding.....	624	Brewer, coffee.....	458	industrial & commercial.....	309	shop.....	472
Blueprinting.....	25	Brick		residential.....	10	shower.....	533
Board		acid-proof.....	375	Building layout.....	595	storage.....	473
insulation.....	181	artificial.....	243	Buildings		utility.....	30, 31
marker.....	440	chemical-resistant.....	375	steel engineered.....	483	vanity.....	290
sheathing.....	50, 51	cleaning.....	371	temporary, rental.....	330	wardrobe.....	458, 472, 473
Boards		Colonial.....	209	Built-in ovens.....	255	wood.....	473
forming.....	88	commercial.....	210	Built-up girders		Cable	
lumber.....	194, 196, 197, 198	common.....	374	carpentry.....	40	antenna.....	130
sheathing.....	61	cutting.....	370	steel.....	383	armored.....	560
treatment.....	206	demolition.....	100	steel framing.....	60	BX.....	560
Board-up		face brick.....	374	Built-up roofing.....	256, 401	Cat 5.....	593
window.....	274	firebrick.....	212	cement, Cold-App.....	258	Cat 5e.....	593
Bobcats, rental.....	323	flooring.....	220	demolition.....	102	Cat 6.....	593
Boilermaker, wage.....	309	jumbo.....	210	Bulb, light.....	192	coaxial.....	592
Boilers.....	578	manhole.....	637	Bulkhead forms.....	340, 342	communication.....	591
expansion tank.....	173	masonry.....	209, 374	Bulkheads, shoring.....	605	computer network.....	593
foundations.....	366	mini.....	211	Bulldozers		electrical.....	561
modules.....	578	mission.....	212	excavation.....	137	Ethernet.....	593
Bollards		modular.....	209, 210	rental.....	138	fiber optic.....	592
bicycle.....	475	mold flashing.....	268	Bullet resistant glass.....	422	flexible armored.....	560
cast iron.....	616	molding.....	108, 222	Bulletin boards.....	441	ice melting.....	561
granite.....	616	mortar.....	209	Bullnose		metal-clad.....	560
Bolt cutters, rental.....	328	Norman.....	209, 210	drywall.....	169	network.....	130, 459, 460
Bolts		Padre.....	210	paver.....	212	phone.....	591
anchor.....	58	painting.....	240	Bumper guards.....	444	power.....	560
carriage.....	232	paving.....	215, 243, 382, 612	Bumper threshold.....	285	punch down.....	460
foundation.....	159	plate.....	382	Bumpers		RG Series.....	592
lag.....	232	pointing.....	371	dock.....	365, 451	RJ Series.....	592
machine.....	232	sandblasting.....	263	highway.....	615	Romex.....	127, 542, 559
tilt-up.....	361	sawing.....	370	Bumps, speed.....	610, 617	signal.....	592
Bond breaker.....	355	standard.....	209, 210	Bungalow fittings, ABS.....	514	snow-melting.....	476, 561
tilt-up.....	363	steps.....	382	Burlap soil stabilization.....	603	tap.....	591
Bonding agents		testing.....	316	Bus duct connection.....	571	testing, computer.....	594
adhesives.....	17, 18	veneer.....	211			tray.....	557
flooring.....	154	walls.....	209, 373			twiaxial.....	593
						twisted pair.....	593

C

Cabinets	
bath.....	220, 290, 446
classroom.....	473
cleaning.....	83
custom.....	472
end panels.....	31
extinguisher.....	493
finish carpentry.....	473
fire hose.....	493
hardware.....	420, 472
hospital.....	473
installation.....	55
kitchen.....	29
labor cost.....	31
laboratory.....	473
lavatory.....	290
lighting fixtures.....	191, 221
linen, shelving.....	270
medicine.....	220, 290, 446
metal.....	472
painting.....	241
shelving.....	270
shop.....	472
shower.....	533
storage.....	473
utility.....	30, 31
vanity.....	290
wardrobe.....	458, 472, 473
wood.....	473
Cable	
antenna.....	130
armored.....	560
BX.....	560
Cat 5.....	593
Cat 5e.....	593
Cat 6.....	593
coaxial.....	592
communication.....	591
computer network.....	593
electrical.....	561
Ethernet.....	593
fiber optic.....	592
flexible armored.....	560
ice melting.....	561
metal-clad.....	560
network.....	130, 459, 460
phone.....	591
power.....	560
punch down.....	460
RG Series.....	592
RJ Series.....	592
Romex.....	127, 542, 559
signal.....	592
snow-melting.....	476, 561
tap.....	591
testing, computer.....	594
tray.....	557
twiaxial.....	593
twisted pair.....	593

Cable Panel.....	130	Cases		Ceilings		Check valves.....	492, 519, 521
Cable testing.....	130, 460	cabinets.....	29, 473	acoustical.....	429	Checkroom equipment.....	453
Cabs, elevator.....	133, 490	laboratory.....	473	drop.....	80	Chemical fire protection.....	455
Café doors.....	118	painting.....	241	plywood.....	54	Chemical-resistant brick.....	375
Caissons.....	608	Cash box, service station.....	450	stained glass look.....	81	Cherry	
Calcimine removal.....	439	Cash dispenser.....	453	suspended.....	79, 429	paneling.....	242
Calcium chloride.....	85, 350	Cashier booth, bulletproof.....	485	tin.....	82	parquet.....	158
Calcium nitrate.....	623	Casing		wood strip.....	54	Chestnut flooring.....	155, 156
California B.A.C.T.....	579	aluminum siding.....	276	Cellar doors		Child protection seat.....	447
California Code 2010.....	579, 581	beads.....	188	steel.....	23	Chilled water pipe.....	494
California pavers.....	212	door.....	53, 108	Cellular blinds.....	297	Chimes, door.....	105
Cambria countertop.....	96	extruded polymer.....	226	Cellulose insulation.....	183	wiring.....	128
Campus network wiring.....	459	finish carpentry.....	52	Cement.....	82	Chimneys	
Cane fiber joint.....	355	hardwood.....	222	adhesive.....	17	anchors.....	151
Canopy		MDF.....	226	cold process.....	258	caps.....	291
commercial.....	471	molding.....	223	coloring.....	85, 218, 356	firebrick.....	212
door.....	21	nails.....	229	concrete.....	351	fireplace.....	152
door or window.....	21	window.....	54	cutting.....	370	flashing.....	404
food service hoods.....	455	Cast iron		duct, envelopes.....	541	flues.....	152, 216, 374
range hoods.....	253	column bases.....	387	lap roof.....	258	masonry.....	220, 374
steel framing.....	387	fittings.....	626	painting.....	240	prefabricated.....	374
Canopy lights.....	587	flanged pipe.....	626	parging.....	382	Chippers	
Cant strips		ornamental iron.....	150	plaster.....	244	pneumatic, rental.....	320
carpentry.....	50	pipe.....	626	roofing.....	256	rental.....	327
roofing.....	182, 403	sections.....	387	testing.....	315	Chisels, rental.....	320
Canvas tarpaulins.....	285	valve box.....	627	tile.....	261	Chop saws, rental.....	328
Cap		valves, AWWA.....	627	white.....	82, 427, 433	Church	
conduit.....	544	Cast-in-place, concrete.....	92	Cement and EPS forms.....	87	acoustical design fees.....	134
door bottom.....	286	Catch basins.....	635	Cement mason, wage		chairs.....	461
sheet, roofing.....	257	demolition.....	333	industrial & commercial.....	309	equipment.....	460
test.....	515	entrance.....	474	residential.....	10	glass.....	470
tile.....	374	gratings.....	387	Cementitious		pews.....	461
Capillary fill.....	339	Catwalks, carpentry.....	46	coating.....	369	Chutes	
Capital forms.....	343	Caulk.....	77	decks.....	369	demolition.....	337
Caps		acrylic latex.....	77	roofing system.....	403	garbage.....	491
ABS.....	516	fireproof.....	78	Central		linen.....	491
black steel.....	494	guns.....	79	air filter.....	176, 180	mail.....	447
copper.....	504	sealants.....	77, 410	heating and cooling.....	174	trash.....	337
CPVC.....	507	strip.....	79	Central vacuum systems.....	290	Cigarette disposal.....	473
drain pipe.....	126	Caution lights.....	22	Ceramic tile.....	287, 427	Cinder rock.....	604
flashing.....	403	Caution tape.....	23	backer board.....	290	Circline lighting.....	191
masonry.....	213, 216	Cavity wall		demolition.....	101, 102, 336	Circuit balancing valves... 173, 539	
molding.....	222	insulation.....	184	facing tile.....	374	Circuit breakers	
post.....	163	reinforcing.....	372	fixtures.....	288	panels.....	575
Capuccino dispenser.....	458	C-clamps, pipe.....	517	installation.....	289	wiring for.....	128
Carbon steel pipe.....	494	Cedar		mosaic.....	288	Circuits	
Carborundum rub.....	95, 356	boards.....	79	vener.....	381	dryer.....	543
Card reader		closet lining.....	79	Cesspools, septic tanks.....	265	exit light.....	542
parking.....	450	fence.....	147, 148	CFL light bulb.....	192	light and power.....	542
security access.....	590	lumber.....	198	Chain hoists, rental.....	329	motor.....	566
Carpenter, wage		paneling.....	242	Chain link fence.....	142, 617	range.....	543
industrial & commercial.....	309	plywood.....	203	demolition.....	333	receptacle.....	542
residential.....	10	roofing.....	259	painting.....	437	switch.....	542
Carpentry		saunas.....	263	Chain railing.....	386	under slab.....	542
assemblies.....	37	shakes.....	259	Chain saws.....	139	Circular louver.....	292
cabinets.....	29, 473	shingles.....	255	rental.....	328	Circular windows.....	299
finish.....	51, 52, 421	siding.....	199	Chair rail.....	55, 223	City cost adjustments.....	12-15
furring.....	52	Cedarmill.....	274	MDF.....	226	Civil engineering fees.....	134
industrial and commercial.....	389	Ceiling		Chairs		Cladding, preformed.....	400
molding.....	226	access hatches.....	407	auditorium.....	474	Clamps	
piecework.....	37	adhesive.....	17	cathedral.....	461	column forms.....	355
piecework rates.....	39, 74	assemblies, wood framed.....	36	reinforcing steel.....	90	concrete, rental.....	322
plates.....	390	beams.....	45	school.....	458	conduit.....	555
rough.....	46	beams, carpentry.....	390	Chalkboard.....	400	ground rod.....	566
square foot costs.....	32	demolition.....	100	Chamfer		pipe.....	517, 518
wall sheathing.....	394	domes.....	79	corner forms.....	355	PVC conduit.....	551
Carpet adhesive.....	18	fans.....	142	strip.....	355	riser.....	517
Carpet tile.....	434	fans, bath.....	139	Changes in costs.....	5	top beam.....	517
Carpets.....	433	grid.....	429	Changing stations.....	447	Clamshell excavators, rental... 322	
access flooring.....	434	joists.....	46, 67	Channel		Clamshovels, rental.....	327
mats.....	220, 474	joists, steel.....	67, 73	hanger.....	555	Classrooms, manufactured.....	480
subcontract.....	76	lighting fixtures.....	79, 190	hat.....	219	Clay	
Carports.....	77	materials.....	80	resilient.....	169, 425	backing tile.....	374
Carriage bolts.....	232	metal pans.....	82	siding.....	199	brick.....	373
Carriers, conveyors.....	491	paint removal.....	233	steel.....	215	pipe.....	635
Cars, elevator.....	133, 490	painting.....	238, 241, 437	strap.....	555	tile, load bearing.....	374
Cartridge fuses.....	575	panels.....	81	vent, rafter bay.....	292	Clay tile roofing	
Carved doors.....	107	radiant heating systems.....	175	Channelizing, earthwork.....	603	demolition.....	102
Casement windows		skylights.....	277	Charbroiler, commercial.....	455	Clean metal primer.....	236
vinyl.....	299	tile.....	82, 430	Charging, electric fence.....	144		
vinyl-clad wood.....	300, 301	tile adhesive.....	429	Check desks.....	452		
		tile, wood fiber.....	429				
		treatments.....	54				

Cleaning									
brick	371	Collar beams		apron	476, 615	paving, removal	332		
cabinets	83	carpentry	48	architectural	85	piles	606		
concrete	356	steel framing	72	beams	339, 345	pipe	633		
doors	83	Collar ties	48	block core fill	213, 378	placing	95, 351		
final	83	Collated brads	229	buggies, rental	321	plank	358		
floors	83	Collated nails	229, 230	building walls	351	plasticized	85		
glass	83, 331	Colonial		bush hammered	356	plyform	203		
glass block	381	brick	209	caisson	608	pouring	95		
masonry	371, 372	columns	84	cast-in-place	354	precast	221, 357		
new construction	83, 331	interior doors	119	coatings	355, 356, 369	pull & junction box	542		
paint preparation	239	storm doors	114	coloring	85, 96, 218, 356, 357	pump mix	85		
painting	436	Color coat, tennis court	466	column forms	340	pumping	350		
pavement joints	612	Coloring agents	218	columns, reinforcing	349	ready-mix	84, 350, 351		
plumbing fixtures	83	concrete	85, 95, 350, 357	conduit envelopes	541	recycling	332		
sewer main	630	mortar	218, 613	core drilling	370	reinforcement	89, 346		
shower stalls	83	Column forms	342	culvert, precast	633	retaining walls	92, 341		
stone	371	caps	344	curb	88, 95, 614	roof decks	369		
storm sewer	631	carpentry	39	curing	356	sandblasting	263		
terra cotta	371	carpentry, steel	57	curing compounds	351	sawing	362, 370		
vacuum systems	290	clamps, rental	322	curing papers	28	saws, rental	321		
walls	83	colonial	134	cutting	370	screeads, rental	322		
windows	83	concrete	340	decking	369	sealant	77		
Cleaning station	457	fireproofing	409	delivery charges	85	sealer	356		
Cleanout		footings	94	demolition	101	shingles	261		
adapter, ABS	516	lally	39	depression forms	341	sidewalk	94, 615		
doors, fireplace	151	lally, steel	57	driveways	84	slab demolition	336		
drainage piping	525	marble	381	edge forms	340	slab forms	340		
plug, ABS-DWV	516	painting	240	embossed finish	96	slab sawing	370		
tees, ABS	515	porch	84	equipment foundations	366	slabs	94, 352, 354, 359, 369		
Cleanup, overhead	310	precast	359	equipment rental	321	slip-formed	353		
Clear cedar siding	199	reinforcing	349	etching	357	snap ties	86		
Clearing		structural steel	384	excavation	338	specialty finishes	95		
brush	594	tilt-up	365	expansion joints	85, 355	spread footings	377		
excavation	136	tube	354	exposed aggregate	95	stain	235		
Clerical help cost	310	wood	84	fiber mesh reinforcing	85	stairways	354		
Clevis hangers	517	Come-a-longs, rental	329	fill	365	stamped finish	96		
Climber, tower	469	Commercial brick	210	fill, columns	384	stamped, subcontract	369		
Clips		Commercial wage rates	309	finishes	95	steps	95, 351, 354		
angle	159	Common brick	374	finishing	96	steps-on-grade	95		
framing	159	Communications	589	fireproofing	407	structural	351, 353		
plywood	162	Communications cable	591	flared apron	476, 615	support poles	360		
Clock		Communion rail	461	flatwork	352, 611	surface prep	437		
receptacles	563	Compacting soil		floor finishes	356, 369	surfacing	369		
wiring	128	embankment	597	floor slab	352	suspended slabs	353		
Closers, door	105, 420	equipment rental	139, 321	footings	94	testing	315		
Closet doors	119	excavation	136, 597	footings, demolition	100	ties	86		
bi-fold	124	roadway	603	form stakes	86	tile	261		
bypass	123	trenches	599	form stripping	88	tile roofing	261		
mirrored bypass	123, 124	Compaction testing	279	form tie	355	tilt-up	362		
Closet flange, ABS	515	Compactors, rental	139, 321	forms	86, 87, 88, 93, 339	topping	95		
Closets		Compartments, cubicles	442	forms, cast-in-place	340	underpinning	605		
cabinets	29, 473	Composite		forms, paving	611	unit masonry	213		
lighting, wiring	128	doors	119	foundations	93	vapor barrier	430		
lining, cedar	79	Composite lumber	98	grade beams	93	vibrators, rental	321		
poles	55	Composition		granite aggregate	85	walks	94, 615		
racks	453	roof, coating for	237	grout	355, 378	wall form	88		
shelves	270	roofing	258	grout mix	85	wall sawing	370		
storage unit	55	Compressors		grouting	96	walls	86, 87, 92, 351, 357		
water	247, 530, 532	foundations	366	gunite	357	waterproofing	294, 355, 397		
Clothes chutes	491	paint	239	hardeners	356	waterstop	91, 349		
Clothes dryers		rental	320	headwalls	638	wedge tie	355		
vent sets	291	service station	449	high early strength	85	work	338		
wiring	128	Computer		ICF	86	Concrete block			
Clothes washers, wiring	128	access flooring	434	inserts	355	demolition	100		
Clothesline units	84	network cable	592, 593	insulated forms	86, 87	glazed	379		
Coat hooks and racks	453	network setup	130, 131	insulating deck	369	natural	213		
Coatings		wiring	130	joints	85	painting	240, 241, 438		
cementitious	369	wiring for educational network	459	keyway	93	pavers	215		
concrete finishes	356	Concrete	84, 338, 350	labor placing	351	retaining walls	375		
deck	437	access ramps	476	landings	476	screen	215, 380		
industrial	436	additives	85, 350, 355, 356	lightweight	85	slump	216		
roofing	256	adhesive	18	line markings	616	split-face	215, 379		
steel	387	aggregate	350	lintels	382	testing	316		
Coaxial cable	592			manholes	636	walls	213, 378		
Code caps	291			masonry units	213, 378	Concrete reinforcing			
Coffee brewer/percolator	458			meter boxes	221	polypropylene fiber	85		
Coil				mix	84	Concrete tile roofing			
framing nails	229			mixer, rental	321	demolition	102		
roofing nails	230			nails	230	Conduit			
Cold box, insulation	399			paint preparation	239	adapter, PVC	550		
Cold milling, asphalt	611			paint removal	234	bodies, PVC	550		
Cold process cement	258			painting	240, 437	bodies, steel	543		
Cold-formed steel framing	56			patching	95	clamps	555		
				pavers	215, 613	EMT	544		
				paving	244, 611				

EMT circuits	547	Coping		Cover plate, electric	565	Cupolas	97
end bell	549	masonry	216, 382	Cover, swimming pool	476	curb inlet protection	604
flexible aluminum	552	metal	403	Coverage loss defined	3	curbing machine rental	325
flexible non-metallic	553	Co-polymer shutters	272	Coverings		curbs	
flexible steel	552	Copper		door	273	asphalt	610
hangers	554	flashing	267, 403	window	273	concrete	88, 95, 614
hangers, PVC	551	grounding devices	565	Covers		demolition	101, 332
hubs	569	gutter	405	canvas	285	elevated slabs	345
IMC	548	nails	267	joint	412	for handicapped	478
intermediate metal	548	pipe	503	manhole	637	granite	614
lightweight	553	pipe, DWV	512	plastic	253, 285	inlets	637
liquid-tight flexible metal	553	pressure fittings	504	CPM scheduling	134, 311	Curing concrete	356, 362
painting	437	roof, cupola	97	CPVC		Curing papers	28
PVC	548	roofing	404	adapter fittings	508	Curtain rods	
rigid steel	543	tubing	505, 512	brass fittings	508	drapery hardware	127
RSC	543	wall ties	372	pipe	507, 508	shower	24
steel	543	window roofs	304	snap-on tubing strap	508	Curtain wall	419
Cones, traffic control	22	wire, THHN	558	transition fittings	508	Curtains	
Conflict resolution	20	wire, XHHW	559	Craft codes	7, 10	industrial and commercial	471
Connection, Internet	130	wood preservative	237	Craft hours defined	3	lift equipment	463
Connections		Corbels, cabinet	31	Craft@Hrs column	10	residential	127
sewer	266	Cord sets	563	Cranes		stage	462
water heater	527	Core		concrete placing	351	Cut and fill excavation	603
Connectors		brick testing	316	hoists	490	Cutting	
computer cable	594	cutting, concrete	370	hydraulic, truck, rental	319	asphalt	371
construction	161	grouting	213, 378	jib	491	boards	454
framing	159, 161	sampling (soil testing)	279	pile driving, rental	322	brick	370
Sealtite	553	Cork		rental	322	concrete	370
straps	566	insulation	399	tower, rental	319	masonry	370
wood	159	running track	465	truck-mounted, rental	319	slabs	370
Conservatories	481	sheathing	435	Crawl hole vents	291	steel	388
Construction		Corner		Crawler dozers, rental	323	walls	370
barricades	22	bead	188, 223, 426	Crawler tractors	137, 596, 601	Cypress flooring	156
camps, manufactured	480	cabinets	31	Credits and acknowledgments	16		
economics	307	guards, metal	387, 404	Creosote	206		
elevators and hoists	319	mold	223	Crew codes	10		
keying	170	molding	222	Crew composition	10		
loans	311	record (surveying)	313	Crew rates	7, 8, 9		
photographs	318	Cornice molding	54	Cribbing and shoring	605		
signs	318	Cornices, painting	240	Critical path scheduling	311		
tools, rental	320	Corrugated		Croll-Reynolds	579, 581		
Consultants' fees	134, 313	fiberglass	150	Cross arms pole	577		
Contact cement	18	glass	422	Cross bridging	41, 159		
Containers, storage, rental	331	mats	220	steel floor joists	61		
Containment, asbestos	338	metal pipe	634	Crossing signal	486		
Contingency	208, 310	metal roofing	260, 400	Cross-linked poly pipe	509		
Continuous spread footings	377	metal siding	276, 400	Crown molding			
Contractor insurance	185	pipe	634	cabinets	31		
Contractor's labor burden		polycarbonate	150	hardwood	222		
industrial & commercial	309	polyethylene pipe	634	labor	54		
residential	10	polyethylene tubing	631	MDF	226		
Control		Cost adjusting, labor	4	pine	224		
erosion	624	Cost adjustments, city	12-15	special cutting	224		
fund fee	311	Cost engineering	313	vinyl	226		
joints	373	Costs listed in this book	4	Crushed rock	18, 126		
pests (soil treatment)	280	Cotton insulation	183	CSI			
valves	523, 618	Cotton mat reinforcing	257	Division 01	310		
Control panels		Counter-flashing	268, 403	Division 02	332		
alarm	591	Counters, bank	452	Division 03	338		
motor	566	Countertop		Division 04	371		
Control switch, fan	141	crystalite	96	Division 05	383		
Controls		Countertop steamers	454	Division 06	389		
hydronic	172	Countertops		Division 07	397		
irrigation	618	cleaning	83	Division 08	412		
motor	566	Corian	97	Division 09	423		
sprinkling	620	engineered stone	96	Division 10	440		
Convertible range hood	254	granite	96	Division 11	449		
Conveying equipment	488	labor costs	96	Division 12	470		
Conveyors		laminated plastic	96	Division 13	475		
belt	491	plastic	473	Division 14	488		
checkroom	453	tile	290, 433	Division 21	491		
concrete, rental	322	Couplings		Division 22	494		
oven	456	ABS	513	Division 23	535		
Cooking equipment	453	black steel	494	Division 26	541		
Cooktops		copper	504	Division 27	589		
residential	255	CPVC	507	Division 31	594		
Coolers	457	drain pipe	126	Division 32	609		
drinking water	534	threaded	543	Division 33	626		
HVAC	180	Court, athletic, surface primer	466	Cubicles	442		
walk-in	457	Cove base	154	Culvert pipe	631, 633		
Cooling		Cove molding	222, 224	Cup holder	23		
air conditioning	180	MDF	226	Cupboards, painting	241		
heat pump	178, 179	Cover		Cupolas			
		plywood	274	weather vanes	97		

D

Dampers, air regulating	
fireplace	151
Dampproofing	397
Danger signs	318
Danish oil stain	237
Deadbolt locks	
commercial	420, 421
residential	170
Debris removal	310, 331, 337
Deck	
painting	438
Decking	
redwood	98
Decks	98
cementitious	369
composite lumber	98
concrete	369
covers	99
diagonal pattern	98
fiber plank	369
finish room	99
flashing	268, 270
flashing, Vycor	27
footings	100
handrail	99
metal	384
metal, demolition	336
nails	228
painting	437
pine	98
posts	99
pressure treated	98
railing	99
redwood	98
roof	50, 99, 384, 385
stain	236
stairs	99
waterproofing	294
yard and patio	100
Decontamination	
lead-based paint	233, 435
PCBs	435
radioactivity	435
toxic chemicals	435
Decora glass block	217
Decorative glass	
ecclesiastical	470

Dehumidifiers, rental	329	gasoline	449	openings, framing	43	lauan	118
Deli case, food service	454	paper towel	445	openings, steel framing	65	Lauan exterior	106
Delivery expense defined	3	ticket	450	paint removal	233	mirrored	125
Delivery, office trailers	330	toilet paper	445	painting, exterior	240	molded face	116, 117
Deluge valves	492	Dispenser, rain gutters	406	painting, interior	241	overhead	164, 415, 483
Demobilization	314	Display case, food	454	peep sights	171	overhead roll-up	416
Demolition	100, 334	Display panel for map, schedule	480	protectors	444	partition	443
asbestos	338	Disposal		pulls	170	patio, sliding	121
asphalt	102	asbestos	338	push plates	170	patio, swinging	120, 121, 122
building	104, 334	fields	265	rehang	52	pet	122
ceiling	100	waste	332	removal	101, 337	pocket, installation	52
concrete	100	Disposers, garbage		repair	52	prehung, exterior	110
concrete block	100	commercial	458	sealant	78	prehung, interior	119, 120
curb	101, 477	residential	128, 248	seals, loading dock	452	prehung, steel	414
doors	101	Dispute resolution	20	seals, weatherstrip	294	prehung, wood	415
fence	333	Distillation, water	250	security switch	589	radiation shielding	484
flooring	101	Distribution, electric	577	shim	52	refrigerator	416
guardrail	333	overhead	577	shoe	286	revolving	416
joists	103	panels	570, 572	sidelites	110	screen, patio	121
manholes	333	switchboards	570	sill, oak	286	screen, security	113
masonry	100	Ditch Witch	598	stop	171, 420	screen, vinyl	113
plumbing fixtures	478	Ditching	136, 597	stop molding	53	screen, wood	113
roof	336	Ditra membrane	94	thresholds	222, 285, 421	screen, metal	113
roofing	102	Divider strips, terrazzo	433	trim	222	security	115
sheathing and siding	102	Dividers		twin door portal	485	security grills	416
stairs	103	partition	443	weatherstripping	294, 421	service	416
subcontract	104	redwood	615	Door stops molding	108	shower	271
toilet partitions	478	Docks, loading	354	Door trim	108	sliding glass	417
walls	103, 335	bumpers	365, 451	Doorbell, wiring	105	sliding, fire	415
windows	103	equipment	451	Doors		sliding, metal	444
wood framing	103, 104	levelers	365, 451	access	253, 266, 418, 525	solid core	106
Demountable partitions	443	lifts	451	accordion	417, 443	steel	415
Dens Glass sheathing	182	seals	451	air curtain	417	steel exterior	106, 109, 110, 111
Deposit boxes	453	shelters	452	aluminum, patio	120, 121	steel, building	483
Depository doors, after hours	453	Documentation, photographs	318	automatic	479	steel, fire-rated	109
Desalinization, water	250	Dolly, rental	329	bar	118	steel, patio	121, 122
Desks		Domes		basement	23	steel, prehung	414
bank	452	lighted ceilings	79	bi-fold	124, 125	stile & rail	116, 117
study	459	playground	467	bypass	123, 124	stock room	418
Detailed block	213	skylights	277	café	118	storm	114, 115
Detection systems	591	Door		camber top	112	strip	418
Detectors		accessories, bypass	124	carved	107	telescoping	417
audio	264	aluminum	419	cellar	23	units, packaged	414
fire	264	bank vault	452	cleanout, fireplace	151	vault	418
infrared	264	bells, wiring	128	closet	119, 123, 124	vinyl, patio	121
security	591	bottom	286	closet, installation	52	with sidelites	111
smoke	264	canopy	21	composite	119	wood	110, 415
vehicle	450	casing	53, 108	convenience store	485	X-ray protective	484
Detour signs, barricade	22	chimes	105	depository	453	Dormer	267, 268
Dewatering	602	cleaning	83	Dutch	444	flashing	268
Diamond lath	188	closers	105	entry	107, 111, 112	louvers	291
Diaphragm meter	638	closers, hinge pin	105	entry, steel	112	studs	48
Diffusers, light	583	coverings	273	exterior	106, 110	studs, steel	71, 72
Digging		demolition	101	exterior, steel	109, 110, 111	Dosch clay	212
concrete work	338	finish carpentry	52	fiberglass	112, 113, 415	Double doors	107, 119
excavation	136	frame protectors	444	fire	415	Double sanitary tee, ABS	514
post holes	144	frames, metal	387, 414	fire-rated	109	Double TY/cross	514
Digital		frames, painting	240	flexible strip	418	Double wye, ABS	514
networking systems	131	frames, pocket	171	flush closet	124	Double-cylinder door handle	170
photography	318	framing	43	flush exterior	106	Double-hung window	303
Digital recorder	592	framing, steel	65	flush interior	116	screen	300
Dimension lumber	194, 201	handle sets	170	folding	122	vinyl	297, 298
Dimmer switches	129, 564	hangers	171	folding, installation	52	Double-track storm window	304
Dimmer switches, fluorescent	564	hangers, pocket	171	foundation access	291	Dough roller	456
Direct overhead	310	hardware	53, 125, 421	frames, wood	415	Douglas fir	194
Directory boards	441	hardware kit	171	French, interior	117	clear	194, 196
Dirt, recycling	332	hardware, exit	171	garage	164	flooring	156, 194, 196
Disability Insurance	285	hardware, garage	165	handicapped	479	Dowel supports	340
Disabled, access for	476	hardware, threshold	285, 286	handicapped, automatic	479	Down light, LED	584
Disappearing stairs	284	hinges	420	hangar	416	Downlights, LED	584
Disconnect switches	577	jamb, exterior	108	hanging	52	Downspouts	
Dishwashers		jamb, interior	118	hardboard	106, 118	industrial & commercial	404
commercial	458	kick plates	170	hollow metal	412	painting	240
electrical	248	knockers	170	interior, café	118	residential	167
plumbing	248	lever latchset	170	interior, fire-rated	109	steel buildings	483
residential	248	lever, privacy	170	interior, French	117, 120	Dozer	
return panels	31	locks	122	interior, hollow core	116	clearing	594
wiring	128	locksets	170	interior, louver	117, 120	excavation	138, 601
Dispensers		louvers	417	interior, panel	116, 117, 119, 120	rental	138, 323
beverage	458	mantels	295	interior, prehung	118, 119		
capuccino	458	mirrors	221	interior, slab	115		
cash	453	openers	164	interior, solid core	116		

Drafting		Drop cloths	285	Edge pulls	171	service entrance cable	557
architectural	126	painting	439	Edgers, rental	327	sprinkler controls	189
plans	20	Dry pack grout	361	Edging		subcontract	127
survey	313	Dry pipe sprinklers	492	redwood	187, 615, 625	switches	564
Draftshield	294	Dryers, clothes		roof	267	switchgear	571
Dragline		circuits	543	sill	286	systems, solar	582
excavation	599	receptacles	563	strip	154	temporary power	319
rental	322	vent sets	291	Educational		transformers	572
Dragon teeth	450	wiring	128	networks	459	tubing	543
Drain		Dryers, hand	446	Educational equipment	458	underfloor duct	557
fields	265	wiring	447	Efflorescence, testing	316	unit heater	535
fittings	512	Dryvit finish, exterior	400	Egg knob locksets	170	valves	189
lines, demolition	333	Drywall		Eggcrate louvers	80	water heaters	130
rock	604	adhesive	17	Egress		wireway	556
Drain pipe		demolition	102, 335	barrier	487	Electrical work	
ABS	512	expansion joints	412	portal	487	poles	577
copper	512	finish	168	window	305	Electrician, wage	
fittings	126	gypsum	168, 293, 423	EIFS exterior wall system	400	industrial & commercial	309
fittings, corrugated	631	insulation board	398	Ejectors, sewage	528	residential	10
Hi-Q	631	nails	229	Elastomeric		Electricity, solar	280
plastic	126, 512	painting	238, 241	flashing	373	Electrostatic precipitators	455
Drain protection	604	primer	234	latex sealant	78	Elevated water tanks	630
Drainage		screws	229	membrane	294	Elevator constructor, wage	
fabric	603	specialties	424	painting	437, 438	industrial and commercial	309
pipe	126, 631	texture	169	pipe insulation	523	Elevator signs, braille	479
slope protection	604	vinyl clad	424	roof coating	257	Elevators	
Drainage systems		wallboard	293	waterproofing	294	commercial	490
rock and sand fill	126	wallboard assemblies	34	Elbows		construction-type	319
Drainboards, countertops	290	Drywall installer, wage		ABS	513	geared	489
laminated plastic	473	industrial & commercial	309	black steel	494	hydraulic	133, 490
stainless steel	457	residential	10	copper	504	passenger	489
tile	433	Drywall taper, wage		CPVC	507	residential	133
Drains		residential	10	CPVC and brass	508	sidewalk	489
area	525	Duct		PVC	506	subcontract	133
fiberglass	634	cable tray	557	Electric service		Embankment grading	597
floor	516, 525	electrical	556	industrial & commercial	570	Embecco grout	355
foundation footing	126	fiberglass	177	residential	127	Embedded steel	387
gratings	387	flex	177	temporary	310, 318	Embossed concrete	96
piping	126	painting	437	Electrical	541	Emergency LED power	585
precast	127, 634	sheet metal	177	alarm systems	128, 264	Emergency lighting	587
rain	127	underfloor	557	boxes	542	Emergency shower	534
roof	525	underground	541	boxes, outlet	561	rough-in	531
rough-in	532	Ductile iron pipe	628	building wire	558	Emissions reduction	579, 581
systems	127	Ducting	253	cable tray	557	Employer labor taxes	
trench	634	Ductwork, painting	437	circuit breakers	567	industrial & commercial	309
Draperies	127, 471	Dumbwaiters	133, 488	conduit	543	residential	10
Drawers	29	Dummy knobs	421	cover plate	565	EMT	544
kitchen work table	454	Dump fees	332	cutouts	577	conduit	544
stainless steel	454	Dump trucks		boxes, outlet	556	conduit circuits	547
Drawings		debris hauling	337, 600	distribution	577	fittings	545
architectural	20	general hauling	137	duct, concrete	541	Enamel gloss, floor and porch	235
as-built	126	rental	139, 324	duct, surface	556	Encapsulated insulation	181
reproduction of	25	Dumpsters, trash	332	fence, charging unit	144	Enclosures	246, 272, 442
Drench showers	531, 534	Duplex nails	231	fuses	575	bus stop	479
Dressing cubicles	442	Duplex receptacles	129, 563	generators	131, 578	cubicles	442, 443
Drill rental	320, 326	Dupont wood flooring	157	generators, rental	326	panel	563
Drilled caissons	608	Durock backer board	290	ground wire	558	sauna	263
Drilling		Dur-O-Wal	219	grounding	566	swimming pool	481
concrete	370	Dursban T-C	280	handy box	562	temporary	331
post holes	617	Dust control	337	heater	175	tennis court	481
rock	595	DWV pipe		heating	536	End cap	260
soil testing	279	ABS	512, 513	junction boxes	563	Endwall flashing	268
steel	388	copper	512	lighting	128	Engineer, overhead	310
well	295	Earthwork		loadcenters	573	Engineering fees	134, 313
Drinking fountain	534	compacting	594	metallic tubing	543, 544	tilt-up construction	362
handicapped	477	Easings		motors	566	Enkebolt molding, cabinets	31
rough-in	531	stair	56, 284	multi-outlet raceway	557	Entrance	
Drip cap	267, 268	stair rail	284	outlet boxes	556	cap, threaded	544
door	287	Eave closure	262	outlets	129, 563	hoods	270
molding, wood	224, 276	Eave louver vents	291	overhead	577	mats	220, 474
Drip edge	267, 268	Eaves, painting	240	panels	572	thresholds	285
Drive shoe	295	Ecclesiastical		poles	577	Entrances	
Driveway gates	143, 165, 618	equipment	460	power, temporary	319	colonial	134
Driveways		glass	470	raceway	556	wood	134
apron	615	Eco-Block	86	raceway fittings	556	Entry doors	107, 111, 112
asphalt	243	Economics division	307	receptacle boxes	556	fiberglass	112, 113
coating	237	Edge forms, concrete	88, 340	receptacles	129, 563	Envelex ceiling domes	79
concrete	84, 94, 244, 615			sensor cable	589	Environmental noise survey	134
demolition	101, 332			service	127	EPA	
forms	88, 94					standards	581
paint removal	234					Tier IV pollution control rating	579
Drop						EPDM	402
ceiling	79, 80						
poles, electrical	318						

EPDM roof coating.....	402	tamping, by hand.....	136	Fan units, heaters	535	privacy.....	149
Epoxy		topsoil, by hand.....	136	Fans		rail.....	145
bed.....	382	tractors.....	138	garage.....	142	rental.....	331
painting.....	437, 438	tree removal.....	594	rental.....	329	sediment.....	604
Epoxy-coated rebar.....	346	trenching.....	136, 597	turbine.....	407	shadowbox.....	149
Epoxy-coated wire mesh.....	349	trucks.....	138	wiring.....	128	silt.....	150
Epoxy-tie adhesive.....	17	wheel loaders.....	598	Fans, ceiling.....	142	split-rail.....	148
EPS forms.....	87	Exhaust		light kit.....	142	swimming pool.....	150
Equipment.....	449	fume system.....	450	Fans, exhaust		temporary.....	22, 331
checkroom.....	453	hoods, food service.....	455	attic.....	141, 142	tennis court.....	466
educational.....	458	range hoods.....	253	bath.....	139, 140	vinyl.....	149
food service.....	453	vents, dryer.....	291	bath switch.....	141	wire mesh.....	143
foundations.....	366	Exhaust fan		bath timer.....	141	wood.....	148
loading docks.....	451	bath.....	139, 140	bath vent kit.....	141	wood gate.....	147
mobilization.....	314	bath, with heater.....	141	bath with heat.....	140, 141	Fertilizer.....	187, 623
overhead.....	310	food service.....	455	bath with light.....	140	Fescue seeding.....	624
pads.....	352	QuieTTest.....	140	commercial.....	455	Fiber	
paint sprayer.....	239	roof vent.....	407	roof vents.....	407	cant strips.....	403
painting.....	436	switch.....	141	utility.....	139, 140	forms.....	344
parking control.....	450	timer switch.....	141	Fascia		roof coating.....	257
service station.....	449	utility.....	139	forms.....	353	Fiber cement	
Equipment rental.....	320	ValueTest.....	140	gutter.....	404, 406	lap siding.....	274
Erickson couplings.....	543	wiring.....	128	gutter adapter.....	406	roofing.....	261
Erosion control		with infrared heater.....	140	metal.....	403	Fiber floor, Tarkett.....	153
fabric.....	604	Exhaust stack.....	581	OSB.....	275	Fiber mesh concrete	
fence.....	604	Existing conditions.....	332	piecework rates.....	39, 76	reinforcing.....	85
landscaping.....	624	Exit door hardware.....	421	soffit system.....	279	Fiber optic cable.....	592
silt fence.....	150	touch bar.....	171	vinyl.....	401	Fiberboard wallboard.....	293
soil covers, stabilization.....	603	Exit signs.....	586	wood.....	49	Fiberglass	
Escalators.....	490	Expanded polystyrene board.....	399	Fasteners, painting.....	437	base sheet.....	257, 258
Escape window.....	305	Expansion		Faucets.....	247, 532	bathtubs.....	245, 533
Estimating, accuracy.....	5	shields.....	373, 555	Feather wedges.....	205	ceilings.....	82
Etch, acid.....	466	strips.....	217	Featherrock.....	604	doors, entry.....	112, 113
Etching concrete.....	357	Expansion joints.....	426	Feed water regulators.....	539	drains.....	634
Eternit.....	261	composition.....	219	Fees		duct.....	177
Ethylene Propylene Diene		concrete.....	85, 355	acoustical design.....	134	insulation.....	181, 398, 399
Monomer.....	402	covers.....	412	appraisal.....	18	panels.....	150
Euro pavers.....	215	glass block.....	381	arbitration.....	19	pipe insulation.....	524
European ISO standards.....	579, 581	lath.....	188	building permit.....	28	septic tanks.....	265
Evaporative coolers.....	177	masonry.....	219	engineer.....	134, 313	shower receptors.....	272
Evaporator coil.....	179	preformed.....	412	estimating.....	313	showers.....	246
Excavation		sealants.....	412	overhead.....	310	tub and shower combination.....	533
air hammer.....	138	Expansion tank.....	249	recycling.....	332	whirlpool bath.....	245
backfilling.....	136	boiler.....	173	scheduling.....	134, 311	Fiberglass-reinforced plastic	
backhoes.....	138	Explosives, loading.....	595	sewer connection.....	311	adhesive.....	18
blasting.....	595	Exposed aggregate finish.....	95, 356	specification.....	314	paneling.....	243
brushing.....	138, 594	Extension cords, rental.....	327	testing.....	317	Fibermesh screen.....	264
bulldozer.....	138	Exterior doors.....	106	valuation.....	18	FICA.....	285
caissons.....	608	flush.....	106	water meter.....	312	Field offices, temporary,	
clearing.....	138	hollow metal.....	412	Felt		rental.....	330
compaction.....	136, 597	jams.....	108	asphalt.....	27, 401	Fields, playing.....	465
dozer.....	601	prehung.....	110	roofing.....	257, 258, 401	Fill	
dragline.....	599	steel.....	414	Felton sand.....	357	caulking.....	79
drilling.....	595, 608, 609	Exterior house paint.....	234, 235	Female adapter		excavation.....	135, 339, 597
embankment.....	597	Exterior Improvements.....	609	ABS.....	515	rock.....	339, 604
equipment rental.....	138, 322	Exterior wall assemblies.....	35	copper.....	512	sand.....	18, 339
erosion control.....	603, 604	Exterior wall system (EIFS).....	400	Fence		slab base.....	339
fine grading.....	135	Extinguishers, fire.....	434, 493	aluminum.....	149	Fill investigation	
footings.....	135	cabinets.....	493	athletic fields.....	465	compacted.....	317
foundation.....	338	Extruded polymer molding.....	226	barbed wire topper.....	618	soil testing.....	279
grading.....	135, 339, 596	Eye wash shower.....	531	basketweave.....	147	Filler	
hand.....	602			board.....	147, 148	block.....	237
hand work.....	135, 339			chain link.....	142, 617	panels, cabinet.....	31
hauling.....	600			demolition.....	333	wood filler.....	238
loaders.....	136, 597			electric.....	144	Filler strip	
loading trucks.....	138, 600			erosion control.....	604	cabinet.....	55
manual.....	602			face board.....	145	chain link fence.....	142
pneumatic.....	138			gate.....	149	Film, polyethylene.....	253
post holes.....	144			hillside labor.....	146	Filter sock.....	126, 631
ripping.....	596			ornamental.....	149	Filter, air, central.....	176
riprap.....	604			painting.....	240	Filters	
rock.....	135			painting metal.....	437	exhaust hood.....	455
scraper-hauler.....	601			pet enclosures.....	143	screen.....	295
shovels.....	135			picket.....	148	water.....	529
slope protection.....	604			picket, vinyl.....	149	Financing, project.....	311
spreading.....	597			plastic.....	22	Fine grading	
spreading material by hand.....	136			plastic safety.....	23	embankment.....	597
sprinkling.....	138			post & rail.....	149	hand.....	135
tamping.....	339, 597, 599			posts.....	144	landscaping.....	623
						pavement.....	243, 609
						slabs.....	339, 596

F

Fabric	
draperies.....	127
erosion control.....	604
lead mesh.....	471
stage curtain.....	462
wallcover.....	435
Fabricated metals.....	387
Facade screen.....	406
Face board.....	145
Face brick.....	210, 374
Faceted glass.....	470
Facing tile.....	374
Facing, marble fireplace.....	208
Factory rep, cost.....	314
Fan lite doors.....	113

Finish carpentry.....	51	Fire retardant treatment.....	207	concrete.....	95, 356	safety tiles.....	432
backing.....	51	Fireblocks.....	45	Float finished.....		sheet vinyl.....	153, 431
blocking.....	51	Firebrick.....	212	glass.....	422	softwood.....	156, 430
cabinet installation.....	55	Fireclay.....	212	Float glass.....	166, 422	Tarkett.....	153
cased openings.....	52	Fireplaces.....	151	Float traps.....	540	terrazzo.....	382, 433
closet poles.....	55	brick.....	212	Floating backing, steel.....	69	tile.....	431, 434
closet shelves.....	55	electric.....	152	Floating hardwood flooring.....	157	tile, vinyl.....	154
countertops.....	96	finish carpentry.....	55	Flood lights, LED.....	585	tongue and groove.....	157
door accessories.....	105, 420	gas-burning.....	152	Floodlights.....	587	vinyl plank.....	432
door casing.....	52	mantels.....	208	rental.....	327	vinyl sheet.....	431
door trim.....	52	masonry.....	220, 374	Floor.....		vinyl tile.....	153, 431
doors.....	52	prefabricated.....	374	adhesive.....	18, 154, 159	wood.....	156, 430
entrances.....	134	surrounds.....	55	assemblies, wood framed.....	33	wood laminate.....	157
fireplace mantels.....	55	wood-burning.....	152	cleaning.....	331	wood strip.....	55, 155, 157
fireplace surrounds.....	55	Fireproof caulking.....	78	decking, steel.....	384	FlowGuard Gold pipe.....	507
flooring.....	197	Fireproofing.....		decking, subflooring... 42, 61, 392		Flue.....	
flooring, wood.....	55	columns.....	409	drains.....	516, 525	fireplace.....	152
folding stairs.....	284	concrete.....	407	drains, ABS.....	516	lining.....	216, 374
furring.....	52	spray-on.....	409	drains, plumbing... 525, 532, 535		Florescent (CFL).....	192
hardware.....	420	testing.....	316	enamel.....	235	Florescent dimmer switches... 564	
job-built stairways.....	283	wood.....	207	equipment rental.....	326	Florescent lighting.....	190, 582
locksets.....	53	Fire-rated.....		flange.....	515	Flush bushing, ABS.....	516
lumber.....	226	doors.....	109	framing.....	34	Flush doors.....	124, 415
mantels.....	208	Fire-rated doors.....	415, 416	furring.....	50	bi-fold closet.....	124
medicine cabinets.....	220	First aid, overhead.....	310	grating.....	387	birch interior.....	115, 116
molding.....	54, 226	Fishtape, rental.....	329	joists.....	34, 40, 41, 390	fire-rated.....	109
paneling.....	54	Fittings.....		joists, piecework.....	38	hardboard.....	106
railings, stair.....	56	ABS bungalow.....	514	joists, steel.....	58, 73	hardboard interior... 115, 116, 118	
running molding.....	55	black steel.....	494	joists, steel blocking.....	61	hardwood exterior.....	110
sauna rooms.....	263	copper.....	503	leveling compound.....	154	lauan exterior.....	106
shutters.....	272	CPVC.....	507	mats.....	220, 473	lauan interior.....	116, 118
siding.....	276	CPVC and brass.....	508	painting.....	238, 437, 438	oak interior.....	116
skylights.....	277	drain pipe.....	126	piecework rates.....	38	steel exterior.....	110
soffits.....	279	electrical.....	563	plank, precast.....	358	steel utility.....	110
stair balusters.....	56	PEX.....	509	plate, steel.....	385	Flush interior doors.....	
stairs.....	56, 281	PEX-AL.....	511	polishing.....	238	lauan.....	116
thresholds.....	285	polyethylene pipe.....	629	radiant heat.....	174	Foam insulation.....	182
wall paneling.....	54	PVC.....	506	safes.....	262, 452	Foam panel adhesive.....	18
wallboard.....	293	PVC water pipe.....	628	sheathing.....	34, 392	Foamglass insulation.....	399
weatherstripping.....	294	Fixtures.....		shellacking.....	238	Foil-backed gypsum.....	424
window sills.....	296	electrical.....	129, 190	sinks, plumbing.....	535	Foil-faced insulation.....	397
window trim.....	53	lamps.....	588	slab.....	352	Folding.....	
Finish grading.....	135, 187, 243	lighting.....	190, 588	slab, concrete.....	94	doors.....	122, 417, 443
Finish hardware.....	421	plumbing.....	535	slab, precast.....	358	locks.....	122
Finish, drywall.....	168	rough-in.....	251, 252	staining.....	238	Folding beds.....	25
Finishes.....	423	Flagpoles.....	448	steel, piecework.....	73	Folding fire partitions.....	444
decks.....	98	aluminum.....	448	varnishing.....	238	Folding stairs.....	284
flooring.....	431	foundations.....	449	waxing.....	238	Food.....	
gypsum wallboard.....	423	Flagstone.....		Floor layer, wage.....		beverage dispenser.....	458
plaster.....	244	floors.....	216, 220	industrial & commercial.....	309	deep fat fryers.....	455
wallpaper.....	293, 435	pavers.....	613	residential.....	10	freezers.....	457
Finishing.....		Flameproofed draperies.....	471	Flooring.....		meat and deli cases.....	454
concrete.....	94, 95, 356	Flanged pipe, cast iron.....	626	access.....	434	mixers.....	457
flooring.....	156	Flanges.....		anti-fatigue.....	432	pizza preparation units.....	454
nails.....	230	ABS closet.....	515	artificial turf.....	465	pot and pan racks.....	456
Fink truss.....	49, 72, 395	black steel.....	494	bamboo.....	157	sandwich preparation units... 454	
Finned tube radiation.....	537	Flash cone.....	268, 269	brick.....	220	service equipment.....	453
Fir.....		Flashing.....		carpet.....	76, 433	stations.....	453
flooring.....	156, 194, 196, 197	aluminum.....	267	carpet tile.....	434	toasters.....	456
Fire.....		aluminum siding.....	276	ceramic tile.....	289	warmers.....	454
alarm breaker.....	570	building paper.....	27	crossband parquet.....	158	work tables.....	454
alarm systems.....	434, 591	compound.....	257	demolition.....	101, 336	Foot grille.....	474
alarms.....	128	copper.....	267	Douglas fir.....	156, 194, 196	Football goal posts.....	465
boxes.....	151	demolition.....	336	finishing.....	56	Footings.....	
brick.....	212	galvanized.....	268, 404	fir.....	156, 194, 196, 197	bell.....	609
dampers.....	151	lead.....	269, 404	flagstone.....	216, 220	bollard.....	616
detectors.....	591	masonry.....	373	floating hardwood.....	157	caissons.....	608
doors.....	109, 415	paper.....	27	gymnasium.....	430, 464	column.....	94
escapes.....	387	ridge.....	260	installation.....	431	concrete.....	84, 86, 93, 94, 351
extinguishers.....	434, 493	roof jack.....	526	marble.....	208, 381	continuous.....	93
hose cabinets.....	493	roofing.....	260, 403	masonry.....	220, 382	demolition.....	100, 335
hydrants.....	627	sealant.....	78	non-slip tile.....	432	drains.....	126
hydrants, demolition.....	334	sheet metal.....	267	parquet.....	430	estimating.....	93
pole tower, playground.....	469	skylight.....	279	pedestal.....	434	excavation.....	135
protection.....	455	stainless steel.....	404	Pergo.....	157	forms.....	339
protection equipment... 491, 492		vinyl.....	270	pine.....	155, 156	keyway.....	93
pumper connection.....	493	Flexible conduit.....	553	plank.....	155	spread.....	377
sprinkler systems.....	150, 491	Flexible strip doors.....	418	quarry tile.....	381, 429	ties.....	86
suppression.....	491	Flexure test.....	315	raised, installation.....	434	tilt-up.....	361
wall hydrants.....	493	Flexwood.....	434	resilient.....	431	Forced air furnaces.....	177
		Flight, photography.....	313	rubber.....	432	Forged steel valves.....	519
		Float finish.....				Forklift, rental.....	324
						Form stakes.....	205

Formboard, fiber deck	369	manhole	636	electric work	128	sill plate	182
Formica countertops	96	see-thru	418	floor	177	Gasoline dispenser	449
Forming		window, painting	239	forced air	177	Gate valves	492, 519
architectural	341	Framing		gas	176, 536	Gates	
landing	346	adhesive	17	gravity gas	176	automatic	165
soffits	346	anchors	161	wall	536	barrier	450
Forms		backing and nailers	47	Furnishings		chain link fence	143
beam	345	beams	45	church glass	470	hardware	143, 148, 618
board	88	blocking	41	window treatment	471	ornamental	165
breaker	355	bracing	44	Furring	395, 425	parking control	450
clamps	355	canopy	387	floor	50	security	115
column	340	carpentry	32	studs	52	temporary	331
concrete	86, 87, 93, 339	ceiling joists	46	wood	50	trash enclosure	366
concrete insulated	86, 87	clips	159	Fuses	575	wood	147
curb	88	connectors	159, 161	FUTA	285	wrought iron	388
footing	88	demolition	103			Gateway, electronic	131
foundation	88	door openings	43			Gauges	524
keyway	88	dormer studs	48			liquid level	540
liner, architectural	365	fascia	49			Gel stain	237
liners	341	fireblocks	45			General contractor	
oil, concrete	355	floor trusses	41			crews	5
plastic	86, 87	furring	50			markup	5, 209
plywood	88, 339, 342, 369	grounds	51			General requirements	310
release	355	ledgers and ribbons	47			Generators	131, 578
shoring	605	lumber	194, 201			exhaust stack	581
slab	340	nails	229			gas turbine, pollution control	
snap ties	86	piecework	37			modules	581
spreader	355	piecework rates	39, 74			motor-driven, pollution control	
stakes	86	posts	45			modules	579
stripping	89	roof	47			power	582
ties	86, 355	roof sheathing	49, 50			rental	326
tilt-up	362	roof trusses	48			steam	285
wall	88, 341	steel	57, 67, 383			wind turbine	132
Formwork		steel collar beams	72			Geodesic dome, playground	467
column	342, 344	steel exterior wall studs	63, 64			Geographic cost	
concrete	339	steel interior wall studs	62, 63			adjustments	12-15
steel-framed plywood	342	steel stud	62			Geotextiles	603, 604
steps	346	subflooring	42			Ginnies	205
stripping	89	trimmers and curbs	48			Girders	
Fortifier products	27	wall plates	42			carpentry	40, 390
Foundation		wall sheathing	51			concrete	351
forms	88, 339	wall stud wood	389			forms	345
forms, reinforcing	88, 346	walls, exterior	42			precast	359
formwork	339	window opening	44			shield flashing	268
insulation	182	Framing nails, screw shank	229			steel	383
investigation, soil testing	280	Free access flooring	434			steel framing	60
layout	189	Freezers				Girts	
placing	351	food service	457			fireproofing	410
poisoning	280	medical	469			steel	383
soil calculations	279	wiring (subcontract)	129			Glass	
stakes	205	Freight elevators	490			artwork	470
trenching	597	French doors	117			bead molding	224
vents	291	interior, double	120			cleaning	83, 331
waterproofing	294	interior, double	120			float	422
Foundations		Frenchwood	120			mirrors	24
access door	291	Frequency meter	571			shelving	270
anchor bolts	363	Fresnel globes	586			sliding doors	417
anchors	58	Fresnel-type spotlight	463			spandrell	419
bell	609	Frieze molding	55			storefront	419
bolts	159	Frieze vents	406			tile	287
caissons	608	Fringe benefits				window	166, 422
coating, asphalt	237	industrial & commercial	309			wire	418
concrete	84, 92, 339, 351, 353	residential	10			Glass block	217, 380
demolition	100, 335	FRP				accessories	217
drains	126	adhesive	18			Glazed	
equipment	366	paneling	243			block	379
excavation	338	Fryers, commercial	455			floor tile	428
flagpoles	449	Fuel grates, fireplace	152			tile	374
footings	93	Fuel storage tanks	540			Glazier, wage	
injected	608	Full-view storm doors	114			industrial & commercial	309
masonry walls	377	Fume hoods	473			residential	10
pile	606	kitchen	455			Glazing	
pole	587	laboratory	473			curtain walls	419
tilt-up construction	361	Fund control fees	311			polycarbonate	423, 482
Fountains		Fungus				sash	422
decorative	486	preventer	268			tempered glass	482
drinking	534	treatment	207			Globe valves	520
drinking, handicapped	477	Furnaces				Glove bags, asbestos	338
ornamental	486	direct vent gas	177			Glove painting	436, 437
rough-in	531					Glue, adhesives	17, 18
wash	534						
Frame seal sets	294						
Frames							
door, painting	240, 241						

Glu-lam beams.....	396	Ground cover.....	625	door opener.....	479	recovery systems.....	580
Goal posts, football.....	465	Ground fault interrupter.....	128	parking.....	477	Heat exchanger foundations.....	366
Goals, soccer.....	465	Ground rod clamps.....	566	symbols, parking lot.....	616	Heat pumps.....	178
Golden Virola paneling.....	242	Ground wire.....	558	Handle sets, door.....	170	accessories.....	179
Gooseneck.....		Grounding.....		Handrails.....		Heat-A-Lamp heater and fan... 141	
stair.....	56	devices.....	128, 566	access flooring.....	434	Heaters.....	
stair rail.....	284	electric.....	566	iron.....	150	baseboard.....	174, 175, 536
Grab bars.....		locknuts.....	566	painting.....	238, 240, 438	electric.....	175
bath.....	24, 445	Grounds, wood.....	51	patio deck.....	99	floor units.....	174, 175
handicapped.....	478	Grout.....		stair.....	56, 281, 284	food.....	454
Gradall.....		brick pavers.....	613	steel.....	386	gas.....	535
rental.....	323	concrete.....	378	wall protection.....	444	gas wall furnace.....	176
trenching.....	597	door frames.....	378	wood.....	224	radiant.....	174, 175
Grade beams.....		forms, tilt-up.....	364	Handy box, electric.....	562	rental.....	326
concrete.....	93	foundation.....	355	Hanger rod.....	518	solar.....	249, 528
formwork.....	88	machine base.....	355	Hangers.....		suspended units.....	176
Graders, rental.....	323	manhole.....	637	angle bracket.....	516	water.....	248, 526
Grading.....		masonry.....	209, 213, 378	channel.....	555	wiring.....	128
embankment.....	597	mix, concrete.....	85	clevis.....	517	Heating.....	
excavation.....	135	pressure injected.....	357, 637	conduit.....	554	ceiling panels, radiant.....	175
fine.....	136, 243	testing.....	316	framing.....	159	central.....	174
finish.....	243, 597	tile.....	288, 289	header and joist.....	161	coil, heat pump.....	179
hand.....	135	Grout, dry pack.....	361	painting.....	437	ductless.....	178
landscaping.....	187, 623	Grouting.....		pocket door.....	171	electric.....	175
lumber.....	205	concrete.....	96	roof.....	392	floor units.....	174
scraper-hauler.....	601	concrete block cores.....	213, 378	swivel ring.....	517	hot water assembly.....	253
site.....	596	pipe joints.....	637	timber.....	161	hybrid.....	174
slab.....	339	pressure.....	357, 637	Hanging doors.....	52	radiant ceiling panels.....	175
tilt-up.....	361	tilt-up.....	361	Hardboard.....	204	radiation.....	537
Grandstands.....	464, 474	GRS conduit.....	543	doors.....	106, 116, 118	solar.....	528
Granite.....		Grubbing.....	138, 594	doors, fire-rated.....	109	Heating and venting.....	538
aggregate.....	350	Guard.....		lap siding.....	275	Hedge trimmers, rental.....	327
aggregate concrete.....	85	corner.....	169, 387, 444	panel siding.....	274	Help, software.....	3
bollards.....	616	dog.....	265	paneling.....	242, 435	Hem-fir.....	195
countertop.....	96	gravel.....	268	wallcoverings.....	435	fascia.....	49
curb.....	614	security.....	265	Hardener, concrete.....	356	Hemlock.....	
decomposed edging.....	625	Guardrail.....		Hardi.....		boards.....	197
masonry.....	381	access flooring.....	434	panel.....	274	doors.....	120
paving.....	382, 614	construction.....	331	plank.....	274	lumber.....	195
terrazzo.....	382	demolition.....	333	trim.....	274	molding.....	108
tile.....	287	highway.....	615	Hardware.....		HERS rating.....	184
Grass.....		Gunite.....	357	bath accessories.....	24	Hex bolts.....	232
artificial turf.....	465	testing.....	316	bi-fold door.....	125	High boy threshold, oak.....	108
hydroseeding.....	187, 624	Gutters.....		cabinets.....	472	High early strength.....	
landscaping.....	187, 624	apron.....	268	commercial and industrial.....	420	cement.....	82
paving.....	244, 615	concrete.....	95, 615	door.....	421	concrete.....	85
seed.....	624	copper.....	405	finish.....	421	High-bay lighting.....	585
sod.....	187	demolition.....	101	garage door.....	165	Highway.....	
Grasscloth.....	435	ice melting cable.....	561	gate.....	148, 618	equipment rental.....	325
Grates.....		inlets.....	637	partition.....	443	stakes.....	205
fireplace.....	152	rain.....	167, 404	pocket door.....	171	Hinges.....	172
tree.....	626	rain disperser.....	406	rule of thumb.....	420	door.....	53, 420
Gratings, steel.....	387	sealant.....	406	threshold.....	285	gate.....	148
Gravel.....		stainless steel.....	406	Hardwood.....		Hip roof.....	36
aggregate.....	18	wire, duct.....	556	doors, fire-rated.....	109	clay tile.....	261
landscaping.....	625	Gutting, demolition.....	335	doors, prehung.....	110	fiber cement slate.....	261
paving.....	244, 615	Gym.....		flooring.....	155, 430	rafters.....	48
pea.....	18	equipment.....	464	flooring demolition.....	101	sheathing.....	50
riprap.....	604	floors.....	430, 464	paneling.....	242	shingles.....	258, 259
slab base.....	94	Gymnasium base.....	412	plywood.....	242	steel rafters.....	70, 74
Gravel guard.....	268	Gypboard demolition.....	335	Hat channel.....	219, 425	trusses.....	74
Gravel stop.....	268	Gypsum.....		Hat racks.....	453	Hoists.....	
demolition.....	336	adhesive.....	17	Hat shelf.....	55	auto.....	450
Gray Board insulation.....	181	ceiling panels.....	82	Hatches, roof.....	407	construction.....	319
Grease.....		decking, poured.....	369	Hauling.....		freight.....	490
filters, exhaust hoods.....	455	demolition.....	102, 335	debris.....	337	rental.....	329
interceptors.....	528	drywall.....	168, 293, 423	excavation.....	600	service station.....	450
Greenboard.....	168	lath.....	187	truck.....	138	Hold down brackets.....	58
Greenhouse.....	167	paint preparation.....	239	Haunch forms.....	342	Hold downs.....	161
panels.....	150	plaster.....	244, 426	Hazard surveys.....	338	Hollow core doors.....	116, 117
Greenwaste recycling.....	332	roofing.....	369	Hazards testing.....	26	Hollow metal doors.....	412
Grey iron.....	387	roofing, demolition.....	336	HDPE drain pipe.....	631	frames.....	414
Griddles, gas.....	456	Grid-WALL.....	87	Header hangers.....	161	Hollow metal, painting.....	437
Grilles.....		Grilles.....		Header pipe.....	602	Home energy rating.....	184
foot.....	474	foot.....	474	Headers.....		Home inspection service.....	26
security.....	416, 485	foot security.....	416, 485	carpentry.....	45, 390	Home networks.....	130
Grills.....	469	Hair interceptors.....	528	yard.....	615	Home office cost.....	310
kitchen, commercial.....	456	Hammering, concrete.....	356	Heads.....		Hood filters.....	455
Grinders.....		Hammers.....		sprinkler.....	621		
pneumatic, rental.....	320	for pile drivers, rental.....	322	Headwalls.....	638		
rental.....	326	rental.....	322, 326	Hearths, marble.....	208		
stump, rental.....	327	Hand excavation.....	135	Heat.....			
Grinding concrete.....	356	Handholes, electric.....	542	detectors.....	591		
Grits, concrete.....	356	Handicapped.....		generation.....	535		
		access.....	476				

L		
Lab refrigerators.....	469	
Labor codes.....	10	
Labor column defined.....	7, 8, 9	
Labor costs		
adjusting.....	4	
crews.....	7, 8, 9	
Labor costs defined.....	3	
Labor productivity.....	4	
Labor rates		
adjusting.....	11	
industrial & commercial.....	309	
residential.....	10	
Labor, painting.....	238	
Lacquer thinner.....	238	
Ladders		
attic.....	284	
horizontal.....	467	
reinforcing.....	372	
rental.....	326	
rolling.....	459	
sliding.....	284	
steel.....	385	
Ladder-type wall reinforcement.....	372	
Ladle rack.....	454	
Lag bolts.....	232	
Lag shields.....	555	
Lally columns.....	39, 57	
Lamb's tongue.....	253	
Laminate shingles, architectural grade.....	258	
Laminate wood flooring.....	157	
Laminated plastic		
cabinets.....	473	
countertops.....	96, 473	
wallcoverings.....	435	
Laminated sandwich panels....	401	
Laminated wood, glued beams and timbers.....	396	
Lamp post wiring.....	129	
Lamps		
CFL.....	192	
fixture.....	588	
fluorescent.....	190, 582	
LED.....	192	
Landings		
concrete.....	476	
forming.....	346	
stair.....	283, 397	
steel.....	385	
Landscape		
irrigation wiring.....	189	
lighting.....	191	
site curbs.....	95	
Landscaping.....	624	
Lane delineator.....	22	
Lane spikes.....	450	
Lap cement.....	257, 258	
Lap siding.....	275	
fiber cement.....	274	
spruce.....	201	
Laser level, rental.....	328	
Latchsets		
commercial.....	421	
passage.....	170	
privacy.....	170	
Latex		
block filler.....	237	
deck, waterproofing.....	294	
house paint.....	235	
masonry paint.....	235	
painting, labor.....	238	
primer.....	234, 294	
stain.....	236	
stucco paint.....	235	
Lath.....	425	
demolition.....	335	
gypsum.....	187	
redwood.....	198	
stakes.....	205	
steel.....	188	
wood.....	205	
Lather, wage		
industrial & commercial.....	309	
residential.....	10	
Lathing.....	425	
Lattice		
molding.....	224	
painting.....	240	
Lauan		
doors.....	106	
Lauan doors		
bi-fold closet.....	124	
flush interior.....	116	
flush prehung interior.....	118	
molded face interior.....	117	
prehung heater closet.....	119	
solid core flush interior.....	116	
Laundry		
clothes chutes.....	491	
clothesline units.....	84	
sinks.....	248	
tub rough-in.....	252	
Lava rock.....	381	
Lavatories.....	533	
bases.....	290	
cabinets.....	290	
china.....	247	
marble.....	208	
rough-in.....	531	
vanities.....	290	
Lawn		
lighting.....	191	
rollers, rental.....	327	
seeding.....	187	
sprinkler system.....	188, 189	
sprinklers.....	619, 621	
Lay-in ceiling.....	81	
Layout.....	37	
engineer.....	310, 313	
foundation.....	189	
stakes.....	205	
survey.....	313, 595	
typical costs.....	314	
Leach fields.....	265	
Lead		
flashing.....	269, 404	
X-ray barriers.....	484	
Lead mesh fabrics.....	471	
Lead-based paint		
removal.....	233, 435	
testing.....	26	
Leaf blower, rental.....	327	
Lease rate.....	581	
Lecterns.....	460	
LED accent lights.....	584	
LED down light.....	584	
LED downlights.....	584	
LED light bulb.....	192	
LED lighting.....	192	
flood.....	585	
LED linear light fixture.....	585	
LED panel lights.....	584	
LED vapor tight lights.....	585	
LED wall pack light.....	585	
Ledger flashing.....	268	
Ledgers.....	47, 391	
LEED		
air conditioning.....	180	
certification.....	536	
hydronic boilers.....	172	
Legal assistance, mobile.....	20	
Let-in bracing.....	44	
Let-in ribbons.....	47	
Letter boxes.....	447, 448	
Letter drop plate.....	420	
Lettering, hand-painted.....	441	
Letters, illuminated.....	441	
Letters, signs.....	441	
Levee excavation.....	603	
Levelers, dock.....	451	
Leveling flooring.....	154	
Levels, rental.....	327	
Lever locksets.....	170	
Lexan.....	482	
L-flashing.....	268	
Liability insurance.....	185	
Library		
ladders.....	459	
shelving.....	459, 472	
Lift slabs.....	353	
Lifting		
cranes, rental.....	322	
panels.....	364	
Lifts		
dock.....	451	
elevators.....	133	
incline.....	133	
rental.....	324	
rolling platform, rental.....	324	
wheelchair.....	133	
Light bulb		
CFL.....	192	
LED.....	192	
Light emitting diode.....	192	
Light fixture		
LED.....	585	
Light standards, demolition.....	334	
Light towers, rental.....	327	
Light, traffic.....	486	
Light-diffusing panels.....	80	
Light-gauge steel framing.....	56	
Lighting.....	190, 588	
area.....	588	
bus stop shelters.....	479	
can.....	191	
court.....	466	
decorative.....	487	
demolition.....	334	
emergency.....	587	
landscape.....	191	
LED wall pack.....	585	
ornamental.....	487	
panelboards.....	572	
poles.....	587	
recessed.....	191	
stage.....	463	
street.....	587	
suspended.....	80	
temporary.....	310	
tennis court.....	466	
vandal-resistant.....	586	
yard.....	587	
Lighting fixtures.....	190, 588	
exterior.....	588	
fluorescent.....	190, 582	
indoor.....	588	
obstruction.....	586	
outdoor.....	190, 588	
outlets.....	129	
Lightning		
arrestor.....	144	
protection.....	129	
rods.....	129	
Lights		
barricade.....	22	
canopy.....	587	
solar powered, barricade.....	22	
Lightweight concrete... 85, 350, 369		
Lime.....	623	
builders.....	218	
field marker.....	218	
landscaping.....	187	
mason's.....	218	
soil conditioner.....	187, 623	
Limestone		
masonry.....	381	
paving.....	614	
soil conditioner.....	623	
Linen chutes.....	491	
Liner, form.....	341, 344	
Link mats.....	220, 473	
Lintels		
masonry.....	382	
steel.....	387	
Liquid level gauge.....	173, 540	
Liquid-tight conduit.....	553	
Listello.....	288	
Loadcenters.....	573	
Loader		
rental.....	138	
Loaders		
crawler rental.....	323	
excavation.....	597	
grading.....	138, 139	
rental.....	324	
wheel, rental.....	323	
Loading docks		
concrete.....	354	
equipment.....	451	
Loading trucks.....	600	
Loading trucks by hand.....	135	
Loan fees.....	311	
Local area network (LAN).....	131	
Lockers.....	447	
demolition.....	337	
Locknuts, grounding.....	566	
Locks		
deadbolt.....	170	
door, folding.....	122	
garage door.....	165	
Locksets.....	421	
colonial knob.....	170	
commercial.....	421	
deadbolt.....	170	
door.....	53	
egg knob.....	170	
keyed entry.....	170	
lever.....	170	
mortise.....	170	
partition.....	443	
Lockwashers.....	232	
Log homes		
finish.....	236	
floor system.....	193	
labor.....	192	
rafter systems.....	193	
siding.....	200	
Log lap siding.....	201	
Loudspeaker systems.....	592	
Louvered doors.....	120	
Louvers		
access doors.....	253, 525	
door.....	417	
egg crate.....	80	
parabolic.....	81	
shutters.....	272	
vents.....	291, 292, 293, 406	
windows.....	299	
Low-boy, trash disposal.....	332	
Low-pressure polyethylene		
pipe.....	629	
Low-Sound bath fan.....	140	
L-straps.....	163	
Lube rack.....	449	
Lumber		
alternative building materials.....	98, 99, 204	
boards.....	194, 196, 197, 198	
building poles.....	204	
cedar.....	198	
common.....	201	
eastern pine.....	197	
finish.....	194, 196	
finish trim.....	226	
framing.....	201	
grading.....	205	

hemlock	195	Margin, profit	208	Mesh		Mobile home port	77
inspection	205	Marine		reinforcing	91, 349	Mobile mediation	20
molding	226	adhesive	78	steel	91, 346	Mobilization	314
oak	198, 222	plywood	203	Message board, traffic control	326	cost defined	3
plywood	202	varnish	236	Metal		piles, earthwork	606
Ponderosa pine	197	Markerboard, chalkboard	440	aluminum screens	388	Mobilization cost defined	3
posts	204	Markers, road	616	buildings	483	Modification factors,	
recycled composite	98, 99	Marking		door frames	414	cost, by area	12-15
recycled plastic	98, 204	parking lot spaces	616	fabricated	387	Modified bitumen	
red cedar	198	pavement	616	facing panels	401	adhesive	258
southern pine	195, 196	Markup	310	lath	425	SBS roll roofing	257
specialty	205	contingency	208	ornamental	388	Modular	
stakes	205	general contractor	5	painting	436, 437	brick	209, 210
timbers	201	project	310	painting, preparation	239	cabinets	29
treated	201	subcontractor	5	pans, ceiling	82	carpet tile	434
treatment	207	Masking, surface prep	439	primer	234, 236	Modulating valves	523
trim	226	Masonry	220, 371	roofing	260	Moisture protection	253, 397
wall sheathing	392	acid-proof	375	screen doors	113	Moisture test, soil	279
West coast	195, 198, 201	anchors	556	siding, painting	437	Moisture-resistant drywall	168
white pine	196	block	213, 378	studs, demolition	335	MDF	226
Luminaire	582	brick	373	trim, painting	436, 437	redwood	222
Luxury vinyl plank	154, 432	cleaning	372	Metal detector	487	softwood	223
LVL Beams	396	demolition	100	rental	329	window apron	53
LVP flooring	432	fireplace	151	Metal roofing	260	Molding	
		furring	50	Metal-clad cable	560	brick	108
		glass block	217	Metal-framed shaft walls	427	cabinet	31
		insulation	183	Meter boxes	221, 573	carpentry	55
		joints	371	Meters		cornice or crown	54
		materials	220, 373	electric	571	door	53, 108
		mortar	219	fees	312	fireplace	55
		nails	230	gas	638	hardwood	222
		paint	235	steam	524	stop	108
		painting	239, 438	water	312, 524	stucco	108
		parging	382	Met-tile	260	T-astragal	108
		pointing	371	Microphone		vinyl	226
		preparation	239	public address	592	Monitor panels	591
		recycling	332	stage	463	Monitors, alarms	264
		reinforcing	372	Microwave	456	Mono rock, concrete	357
		sandblasting	263	cabinets	31	Monolithic topping, concrete	357
		sawing	370	Midget louvers	292	Monorail for electric hoists	490
		steam cleaning	371	Milano awnings	471	Monuments, survey	313
		surface prep	437	Milgard	299	Mop resilient floor	331
		testing	316	Milling, cold, asphalt	611	Mop sink	457, 534
		waterproof	235	Millwork, treatment	207	rough-in	531
		waterproofing	294	Millwright, wage		Moped racks	475
		Mass excavation	601	industrial & commercial	309	Morgue equipment	470
		Mastercure	95	residential	10	Mortar	209
		Mastic		Mineral insulation	399	block	213
		adhesives	18	Mineral spirits	238	cement	82
		painting	437	Mineral surface roll roofing	257	color	218, 613
		roofing	257	Mini split	178	glass block	217
		tile	288, 289	Mini-blind door	112	masonry	209, 218, 219
		Mat reinforcing steel	349	Mini-blinds	296	mix	82
		Material costs defined	3	Mini-brick	211	paving	614
		Material demolition	337	pavers	212	shower bed	272
		Material handling systems	491	Mini-mat reinforcing	349	testing	316
		Material hoist	319	Mining camp barracks	480	tile	289
		Material lifts, rental	324	Miradrain	603	trowel-ready	219
		Mats		Miraflex	604	Mortise	
		entry	220, 473, 474	Miraflex	181	hinges	172
		erosion control	603	Mirrored doors		lockset	170
		MC cable	560	bi-fold	125	Mosaic and terrazzo worker, wage	
		MDF molding	226	bypass	123	industrial & commercial	309
		MDO plywood	203	Mirrors		residential	10
		Meat and deli case	454	arches	221	Mosaic tile	288, 428
		Meat saw	454	bath accessories	24	Moss preventer	268
		Mechanical drawing,		beveled edge	167	Motor	
		architectural	126	door	221	connection	567
		Mediation		framed	221	generator sets	578
		fees	19	frosted	221	starters	567
		mobile	20	medicine cabinet	220	Motor graders, rental	323
		Medical refrigerators	469	unframed	423	Motorcycle racks	475
		Medicare payroll taxes	285	vanity	221	Motors, electric	566
		Medicine cabinets	220, 446	Mission		Movable partitions	443
		Medium-density plywood	203	brick	212	Moving	
		Membrane		paver	212	excavated material	600
		detaching	94	tile roofing	261	stairs	490
		Ditra	94	Miter saws, rental	328	structures	338
		poly film	253	Mitt, painting	436	Mud sills	389
		roofing	401	Mix design, concrete	315	anchors	58, 161
		slab	94, 339	Mixers, cement, rental	321	Mulch	187
		underlayment	94	Mixers, food	457	Mullion casing	224
		waterproofing	294	Mixing valves, thermostatic	540	Murphy wall beds	25

M

N		
Nailer strip, carpentry.....	47, 390	
Nailers, rental.....	327	
Nailing sheathing.....	392	
Nailite.....	277	
Nails		
aluminum.....	231	
box.....	227	
brads.....	229	
casing.....	229	
coil.....	229	
coil roofing.....	230	
collated.....	229, 230	
common.....	227	
deck.....	228	
drywall.....	229	
duplex.....	231	
finishing.....	230	
framing.....	229	
joist hanger.....	230	
masonry.....	230	
plasterboard.....	230	
scaffold.....	231	
screw shank.....	229	
siding.....	231	
sinkers.....	228	
stainless steel.....	230	
stick.....	229	
vinyl-coated.....	228	
Napkin dispenser.....	445	
Narrowline patio doors.....	121	
Natural gas		
meter.....	638	
rough-in.....	252	
NCX treatment.....	207	
Needle gun finish.....	356	
Needle scaling paint removal.....	233	
Neo-angle shower.....	272	
Neoprene		
gaskets.....	403	
joints.....	412	
weatherstrip.....	421	
Nets		
safety, scaffolding.....	329	
tennis.....	466	
Netting, stucco.....	188	
Network cable.....	130, 459, 460	
Networking systems.....	131	
Networks		
educational.....	459	
residential.....	130	
Newel		
posts.....	56, 253, 281, 282, 283	
NFPA fire sprinklers.....	150	
NM-B cable (Romex).....	559	
Noise analysis.....	134	
Non-metallic		
cable (Romex).....	559	
conduit, flexible.....	553	
Non-slip strips.....	220, 432	
Norman		
brick.....	209, 210	
pavers.....	212	
Nosing		
flooring.....	155	
sill.....	286	
steel.....	387	
Nozzle, sandblast, rental.....	325	
Numbers, house.....	172	
NuTone.....	140, 141, 254	
Nuts, hex head.....	232	
Nylon carpet.....	76, 433	
parquet.....	158	
plywood.....	203	
threshold.....	108, 222, 286	
Obstruction lighting.....	586	
Octagonal window.....	303	
Office		
clerk.....	310	
expenses.....	310	
job site, temporary, rental.....	330	
manager cost.....	310, 314	
overhead.....	208	
partitions.....	443	
Offices		
manufactured.....	480	
temporary.....	310	
temporary, rental.....	330	
Oil		
concrete form.....	355	
storage tanks.....	540	
Oil and latex stain.....	236	
Oil-based		
enamel.....	236	
exterior primer-sealer.....	234	
stain.....	236, 237	
Olefin carpet.....	76	
Openers, garage door.....	164	
Openings.....	412	
Operating engineer, wage		
residential.....	10	
Orchard clearing.....	594	
Organic impurities.....	314	
Ornamental		
fence.....	149	
gates.....	165	
metals.....	253, 388	
railings.....	386	
rock.....	604	
screens.....	388	
OS&Y valves.....	492, 519	
OSB (Oriented Strand Board).....	275	
paneling.....	392	
panels.....	203	
roof panels.....	392, 393	
roof sheathing.....	194	
sheathing.....	42, 51, 62, 391, 392	
siding.....	275	
subfloor.....	42, 62	
Osmosis filters, water.....	529	
Outdoor lighting.....	191, 588	
Outlet boxes, electrical.....	561	
Outlet circuit receptacle.....	542	
Outlets, electric.....	129, 563	
Outside corner molding.....	226	
Ovens		
built-in.....	255	
cabinets.....	30	
commercial.....	456	
convection.....	456	
electrical work.....	129	
microwave.....	456	
pastry.....	456	
residential.....	255	
Overhang, painting.....	240	
Overhead.....	310	
costs.....	310	
markup.....	208	
Overhead doors.....	415	
Overhead electrical		
distribution.....	577	
P		
PA (Public Address) system.....	464	
Padre brick.....	210	
Pads		
carpet.....	76	
equipment.....	352	
Paging systems.....	592	
Paint		
pool coating.....	237	
removal.....	233, 435	
remover.....	237	
testing.....	26	
textured.....	235	
thinner.....	238	
traffic.....	237	
Painter, wage		
industrial & commercial.....	309	
residential.....	10	
Painting.....	241	
athletic courts.....	467	
cleaning, prep with		
power tools.....	436	
cleanup.....	331	
clear finish.....	236	
compressors for spray		
painting.....	239	
concrete.....	437	
conduit.....	437	
cost breakdown, subcontract.....	239	
curbs, red.....	616	
deck.....	437	
decks.....	437	
door frames.....	240, 241	
epoxy.....	437, 438	
exterior.....	238, 241	
exterior latex.....	235	
fence.....	240	
floor.....	438	
handrails.....	438	
industrial.....	436	
interior.....	235, 238, 241	
interior prep.....	439	
joists.....	437	
latex.....	235	
latex exterior.....	235	
masonry.....	235, 438	
mastic.....	437	
oil stain.....	237	
pipe.....	437	
pool.....	438	
porch.....	438	
porch and floor.....	235	
roof.....	257	
rule of thumb, subcontract.....	239	
sandblasting.....	263	
shingles.....	438	
siding.....	437, 438	
speed bumps.....	610	
spheres.....	437	
spray.....	239	
sprayers, rental.....	328	
stain.....	237	
steel.....	436	
stucco.....	235, 437	
subcontract.....	239	
surface prep.....	436, 437	
swimming pool.....	438	
tanks.....	437	
urethane finish.....	236	
varathane finish.....	236	
waterproof.....	237	
waterproofing.....	236	
wood deck.....	438	
wood finish.....	236	
wood preservative.....	237	
Paling, rail.....	99	
Pan forms.....	345	
Pan racks.....	456	
Panel		
adhesive.....	18	
box, wiring.....	129	
circuit breaker.....	575	
enclosures.....	563	
molding.....	224	
Panel ights, LED.....	584	
Panel roofing		
steel.....	260	
Panelboards, electrical.....	572	
Paneling		
beaded.....	242	
birch.....	242	
cedar.....	79, 242	
FRP.....	243	
Golden Virola.....	242	
hardboard.....	242, 435	
hickory.....	242	
maple.....	242	
oak.....	242	
pine.....	242	
red oak.....	242	
sound reduction.....	464	
vinyl-clad.....	243	
wainscot.....	242	
wall.....	54	
Z-brick.....	243	
Panelized		
roof system.....	392	
shingle siding.....	276	
Panels		
breaker.....	572	
fiberglass.....	150	
greenhouse.....	150	
light-diffusing.....	80	
polycarbonate.....	150	
radiant heating, ceiling.....	175	
roofing, solar.....	280	
sun.....	150	
wood walls.....	394	
Panic button.....	264	
Panic door hardware.....	171, 421	
Pans, water heater safety.....	526	
Pantry cabinets.....	30	
Paper		
building.....	27, 28	
dispensers.....	445	
roofing.....	258	
wallcover.....	434	
Paperhanging.....	293, 434	
Parabolic louvers.....	81	
Parapet		
coping.....	268	
forms.....	353	
reglet.....	365	
Parargeting, masonry.....	382	
Parging		
masonry.....	382	
Park		
benches.....	474	
grills.....	469	
surveillance.....	486	
Parking		
access control.....	450	
blocks.....	617	
bumper.....	615	
control equipment.....	450	
handicapped symbol.....	616	
lot, paving.....	610	
reflective lines.....	616	
stalls, for handicapped.....	477	
traffic symbols.....	616	
Parquet flooring.....	158, 430	
Particle emissions reduction,		
pollution control.....	581	
Particleboard.....	204	
carpentry.....	395	
underlayment.....	395	
Parting bead.....	224	
Partitions		
cubicles.....	442, 443	
demolition.....	335	
dust control.....	337	
fire rated.....	444	
folding doors.....	443	
framing, piecework.....	37, 73	
framing, steel.....	73	
marble, toilet.....	381	
metal.....	442, 443	
non-bearing.....	443	
office.....	443	
toilet.....	442	
wire.....	444	
Passage latch.....	170, 421	
Passenger elevators.....	489	
Passive solar heat.....	249	
Paste wood filler.....	238	
Pastry oven.....	456	

Patch panel	460	Pergo wood flooring	157	stakes	205	demolition	102, 335
Patching		installation kit, rental	326	timber	202	ground	224
concrete	95, 365	Pergola	99	white	196	joints	412
Path lighting	191	Perimeter door seal	452	Pipe		labor	244, 426
Patio		Perimeter wall insulation	182	ABS	126, 512	mixer, rental	321
blocks	613	Perling, steel	72	asbestos removal	338	painting	241
carports	77	Perlite soil conditioner	623	black steel	494	ring	561
cover	21	Permanent bond adhesive	258	bollards	616	soffits	244
roof	99	Permits		cast iron	626	stucco	427
tile	220	building	28	clamps	518	Plasterboard	
Patio doors	121, 122	well drilling	295	clay	635	drywall	423
aluminum	120	Pest control		cleaning	630, 631	nails	230
fiberglass, swinging	122	soil treatment	280	columns	384	Plasterer, wage	
gliding, vinyl	121	wood treatment	207	concrete	631, 632	industrial & commercial	309
hinged, vinyl-clad	120	Pet		conveyors	491	residential	10
pet	122	doors	122	copper	503, 512	Plasterer's helper, wage	
sliding wood	121	enclosures	143	corrugated metal	633, 634	residential	10
steel, double	122	screen	123	corrugated polyethylene	631	Plasterer's helper, wage	
swinging, double	120	Petroleum storage tanks	540	CPVC	507, 508	industrial & commercial	309
vinyl	121	Pews	460	culvert	633	residential	10
Pavement		PEX pipe	509	cutters, rental	328	Plastering	244, 426
asphaltic	243	PEX-AL pipe	511	demolition	333	fireproofing	409
breakers, rental	320, 325	Pharmacy refrigerators	469	drainage	126, 512	stucco	427
concrete	84, 94, 244, 611	Phone support	5	ductile iron	628	Plasterkraft	27
demolition	102, 332	Phones		DWV	512	Plastic	
line marker, rental	325	temporary	310	elliptical	632	countertops, laminated	473
line markings	616	wiring	591	equipment rental	328	drain pipe	126
marking, removal	333	Photo mapping, aerial	313	fire protection	508	forms	86, 87
sawing	371	Photo micrographs	317	foundation drains	126	laminates	435
stripers, rental	325	Photoelectric		gas	252, 638	lumber	99, 204
striping	616	sensors	589	grouting	637	resin glue	18
sweeping	612	switches	565	guard	365	sewer pipe	266
symbols	616	Photographs		guides	518	shutters	272
Paver		aerial	313	inspection	629, 630, 631	siding	276
Turfstone	615	construction	318	insulation	523	skylights	277
Pavers		retouching	318	insulation, asbestos removal	338	speed bumps	617
brick	212, 382	Photovoltaic systems	582	insulation, painting	437	tarps	285
bullnose	212	Picket fence	148, 149	jacking	638	tile	429
concrete	215, 382	painting	240	levels, rental	328	vapor barrier	253, 352, 353
interlocking	382	Pickling stain	237	locating	266	Plasticized concrete	85
landscaping	613	Picture frame molding	224	markers	318	Plate straps	163
masonry	613	Picture rail	55	painting	437	Plates	
masonry grid	382	Picture window	299	perforated	631, 632	carpentry	40, 57, 390
mexican	288	Pictures, job site	318	PEX	509	carpentry piecework	42, 67
rubber	467	Piecework		PEX-AL	511	door hardware	170, 421
slate	382	metal carpentry, floor sheathing	74	piles	608	electrical	565
split	212	metal carpentry, rafters	75	plastic	126	splash	255
terrazzo	382	metal carpentry, roof framing	74	polyethylene	126, 618, 621, 638	switch	23
Paving		metal carpentry, roof sheathing	76	polyethylene corrugated	634	Platform lifts	
asphalt	243, 609, 610	rough carpentry	37	PVC	512	dock	451
brick	243, 612	rough carpentry, floor sheathing	38	PVC Schedule 40	506, 620	rental	324
cold milling	611	rough carpentry, roof sheathing	39	PVC Schedule 80	506	Platform, scaffold, purchase	330
concrete	84, 94, 244, 611	steel framing	73	PVC sewer pipe	266	Playground equipment	467
demolition	102, 332	Pier		railing	386	Playing fields, synthetic	465
equipment rental	325	blocks	39	rolls	518	Plenum cable	593
grass	244, 615	caps	389	sewer	265	Plexiglas	167, 422, 480
joint treatment	613	pads	39	sewer, PVC	630	Plinth block, MDF	226
machine, rental	325	Pilasters	134	sterilization	629	Plugmould	557
parking lots	610	cabinets	31	storm	632	Plugs	
repair	611	molding	55	straps	518	cleanout	516
stones	382	painting	240	troubleshooting service	266	electrical	564
subcontract	243	Pile caps, concrete	340	TV inspection	637	test	515
systems	244, 615	Pile driver, wage		valves	523	Plumber, wage	
Turfstone paving	615	industrial and commercial	309	vitrified clay	266	industrial & commercial	309
Payment bonds	186	Pile driving	606	water, PVC	628	residential	10
Payroll taxes	285	Pile driving, rental	322	Pipefitter, wage		Plumber's flash cone	404
PCBs, removal	435	Pile foundations	606	industrial and commercial	309	Plumber's tape	518
Pea gravel	18	Piles		Piping, gas	252	Plumbing	494
concrete	85	landscaping	625	Pitch pockets	404	access doors	253, 525
landscaping	625	treatment	206	Pits, excavation, dug by hand	136	area drains	525
riprap	604	Piling, sheet steel	605	Pizza preparation unit	454	assemblies	251, 530, 532
Peat humus	623	Pine		Placing concrete	95, 349	cleanouts	525
Pedestal flooring	434	building poles	204	Plan check fee	28	copper DWV	512
Pedestrian bridge	487	decks	98	Plank		equipment rental	328
Peep sights	171	eastern	197	flooring	56, 155	fixtures	535
Pegboard, hardboard	435	flooding	155, 156	precast concrete	358	fixtures, cleaning	83
Penetrating stain	236	jamb sets	118	scaffold, aluminum extension,		floor drains	525
Penny nail sizes, defined	227	lumber	197	purchase	330	for handicapped	478
Pension costs defined	3	paneling	242	Plank flooring		piping	532
Penta treated post	204	Ponderosa	197	vinyl	432	roof drains	525
Percolation testing	265	siding	199	Plans	25	rough-in	251, 532
Percolator, coffee	458	southern	195, 196	Plants, landscape	624	systems	251
Perforated pipe	632			Plaques	442	water softener	250
Performance bonds	186			Plaster		Plyclips	162
				accessories	426	Plyform	203, 339

Plywood.....	203, 391	Polyisobutylene.....	412	Pouring		Profit, markup.....	208, 310
backboard.....	460	Polyisocyanurate		concrete.....	95, 351	Project	
birch.....	203	insulation.....	182, 398	insulation.....	183, 398	cost adjustments.....	12–15
'board-up'.....	274	Polypropylene mesh reinforcing.....	85	Pour-stop forms.....	340, 342	financing.....	311
cap molding.....	226	Polystyrene		Powder-driven fasteners.....	231	manager cost.....	310
cedar.....	203	board.....	398	Power		scheduling.....	311
ceiling.....	54	insulation.....	181, 182, 398, 399	cable.....	560	Propane	
deck, waterproofing.....	294	insulation board.....	398	conduit.....	543	furnaces.....	176
demolition.....	102	roof deck.....	399	distribution.....	577	tanks.....	541
exterior.....	202	Polyurethane		EMT.....	547	water heaters.....	249
fence.....	331	floor finish.....	56	generation.....	131, 582	Property boundaries.....	313
forms.....	88, 339	insulation.....	184	panels.....	572	Provisa range hood.....	254
framing clips.....	162	paint.....	236	solar.....	582	P-traps, ABS.....	516
lumber.....	202	painting.....	438	temporary, pole rental.....	310, 318	Public address systems... 464, 592	
marine-grade.....	203	sealant.....	410	underground.....	541	Pull box, electrical.....	542, 562
MDO.....	203	Ponderosa pine		Power factor meter.....	571	Pull plates.....	170, 421
oak.....	203	boards.....	197	Power generator exhaust stack.. 581		Pulls, edge, pocket door.....	171
paneling.....	242, 392	lumber.....	197	Power ventilators		Pulpits.....	460
piecework rates.....	39, 74	mantels.....	208	attic gable.....	142	Pump mix concrete.....	85
roof panels.....	392	Pool, swimming		roof-mount.....	142	Pumper firehose connection.... 493	
sheathing.....	42, 51, 61, 391	coating.....	237	Precast		Pumping	
sheathing, piecework.....	39, 76	complete installation.....	475	beams.....	359	concrete.....	350, 351
siding.....	203, 275	cover.....	476	columns.....	359	dewatering.....	602
softwood.....	202	deck.....	369	concrete.....	357, 633	well.....	295
structural.....	203	fences.....	150	culvert.....	633	Pumps	
subfloor.....	42, 61	gunite.....	357	double tees.....	360	electrical connections.....	129
subfloor, piecework.....	39, 76	heaters.....	250	drains.....	634	foundation.....	366
treatment.....	207	painting.....	237, 438	floor plank.....	358	gasoline.....	449
underlayment.....	432	resurfacing.....	369	floor slab.....	358	rental.....	324
window covering.....	274	Popcorn		girders.....	359	sewer.....	265
Pneumatic		ceiling, removal.....	169	joists.....	359	sump.....	528
demolition.....	103	Popcorn ceiling.....	169	manholes.....	636	sump, wiring.....	129
door closers.....	105	Poplar flooring.....	155	panels.....	357	wiring.....	130
excavation.....	138	Pop-up sprinklers.....	189	stairs.....	360	Punch down, network cable ... 460	
hammer.....	596	Porcelain tile.....	287	Precipitators.....	455	Punch-down blocks.....	593
pipe systems.....	491	Porch		Pre-engineered buildings.....	483	Purlins	
tampers.....	599	columns.....	84	Preformed siding.....	400	anchors.....	161
tools, rental.....	320	enamel.....	235	Prehung doors ... 52, 118-120, 415		carpentry.....	48, 390
tube systems.....	491	enclosed.....	167	double.....	119	fireproofing.....	410
Pocket doors.....	171	lifts.....	133	exterior.....	109, 110, 111	hangers.....	161
hangers.....	171	painting.....	240, 438	fire-rated.....	109	steel.....	383
hardware.....	53, 171	posts.....	84	French.....	120	steel framing.....	72
kit, converging.....	171	rail.....	253	heater closet.....	119	Purse shelf.....	442
Pointing, masonry.....	371	Porous paving.....	244	oak.....	119	Push plates.....	170, 421
Poisoning soil.....	280	Portable structures.....	480	patio, steel.....	121	Putty, glass.....	239
Poles		Portable toilet (Port-a-Potty).... 310		steel.....	111, 112, 414	PV (photovoltaic)	
building.....	204	Portland cement.....	82	Preliminary soil investigation... 279		solar equipment.....	280
closets.....	55	Post		Prepare surface,		PVC	
concrete.....	360	anchors.....	163	painting.....	239, 437, 439	clamp.....	551
cross arms.....	577	bases.....	162	Presentation		conduit.....	548
demolition.....	334	caps.....	163	board.....	440	conduit body.....	550
flag.....	448	column forms.....	340	preservation, lumber.....	207	conduit box adapter.....	549
foundations.....	587	indicators.....	627	preservative, wood.....	237	conduit with wire.....	551
job sign.....	318	painting.....	438	Pressure		end bell.....	549
lighting.....	587	Post holes.....	144	controls.....	524	flashing.....	270
lumber.....	204	fences.....	617	gauge.....	524	jacketed copper tubing.....	505
playground.....	467, 469	footings.....	617	grouting.....	357	pipe.....	265, 506
power distribution.....	577	Postal specialties.....	447	mats.....	264	pipe, Schedule 40.....	620
pressure-treated.....	205	Posts		regulators, gas.....	638	reducer bushing.....	549
removal.....	334	athletic equipment.....	465	regulators, hydronic heating.... 539		sewer pipe.....	266, 630
temporary utility power.....	318	barrier.....	452	treatment, lumber.....	207	water pipe.....	628
treatment.....	206	bollards.....	616	vacuum breaker.....	312		
Polishing		building.....	204	Pressure washer, rental.....	328		
floors.....	238	cabinet.....	31	Pressure washing.....	239, 436		
woodwork.....	241	carpentry.....	39, 45	Pressure-reducing valves ... 522, 539			
Pollution control.....	579, 581, 604	deck.....	99	Pressure-treated lumber.....	201		
Poly E Pipe.....	621	fence.....	144	Prestressed concrete.....	360		
Polybutene tape.....	412	guardrail.....	615	Prime coat, pavement.....	611		
Polycarbonate		jackposts.....	186	Primer			
glazing.....	482	newel.....	56	asphalt.....	466		
sheets.....	166, 423	porch.....	84	clean metal.....	236		
skylights.....	277	pressure-treated.....	205	linseed.....	234		
Polyester fabric.....	257	redwood.....	204	metal.....	236		
Polyethylene		sawn.....	204	painting.....	239		
corrugated pipe.....	634	treatment, lumber preservation.. 206		sealer, oil-based.....	234		
film.....	253	yellow pine.....	204	Prints, plans.....	25		
gas pipe.....	638	Pot hooks.....	454, 456	Privacy latchset.....	170		
membrane, slab... 94, 339, 352, 353		Pot racks.....	456	Processed lime.....	218		
pipe.....	126, 618	Pot wash sink.....	457				
tarps.....	285	Pour strip, tilt-up.....	362				
tilt-up.....	362						
Poly-faced insulation.....	181						

Q

Quality control engineer.....	313
Quantities defined.....	3
Quarry tile	
flooring.....	381, 429
masonry.....	220, 381
wall tile.....	381
Quarry work.....	596
Quarter round mold.....	225
Quarter round molding.....	222
Quartz heaters.....	175
QuietTest exhaust fan.....	140
Quietzone.....	183
Quonset huts.....	483

R			
Raceway, electric	556	Rastra Block	87
Racks		Rates, labor	7, 8, 9
coat and hat	453	Rattan black paper	27
garment	453	Reactivity testing	314
kitchen	456	Ready-mix concrete	84, 350
ladle	454	Rebar	
pots and pans	456	chairs	348
towel	24	concrete	89, 346
Racks, security		epoxy-coated	346
bicycle	475	footings	346
motorcycle	475	masonry	372
Radial wall forms	342	rings	348
Radiant heat, floor	174	slabs	346
Radiant heating	175, 479	splicing	348
Radiation protection	484	stirrup	347
Radiators, heating	537	Receptacles, electric	129, 563
Radio studio	488	cover plate	565
Radioactivity, removal	435	outlet circuit	542
Radon gas, testing	26	wiring	129
Rafters	36, 390	Receptors, shower	272
bay vent channel	292	Recessed lighting	191
demolition	103	Re-coat	
log	193	roofing	402
piecework rates	39	Recording meters	571
rough carpentry	47	Recycling fees	332
spacing	292	Red cedar	
steel framing	70	beams and timbers	201
steel, piecework rates	74	boards	198
timber	193	fence	148
vents	292	lumber	195
Rail		shakes	259
communion	461	shingles	259
fence	145, 148	siding	199
guard	331	Red oak	
hand	150	boards	198
molding, cabinets	31	closet doors	124
painting	438	doors	117
stair	283	Red oxide primer	234
Railing		Red rosin sheathing	27
access flooring	434	Reducer strip, flooring	155
aluminum	386	Reducer, drain pipe	126
brass	386	Redwood	
for handicapped	476	benderboard	187, 625
highway	615	deck stairs	99
painting	238, 240	decking	98
patio deck	99	fascia	49
porch, steel	253	fence	147, 148
stair	56	headers	615, 625
stair, wood	281, 397	lumber	195, 198, 201
steel	253, 386	molding	222
temporary	331	saunas	264
tubular	386	siding	199
wrought iron	386	strips, chain link	142
Railroad demolition	334	treads	99
Rain diverter	268	Reflective signs	617
Rain gutter		Refrigeration, insulation	399
stainless	406	Refrigerators	
steel	406	backbar	457
Rain gutters	167	electrical work, subcontract	129
Raingear, copper	405	food service	457
Raised floors	434	medical	469
Rammers		morgue	470
compacting	599	wiring, subcontract	129
rental	321	Reglet	
Ramp forms, riser	346	copper	268
Ramps		parapet	365
access flooring	434	Regulator valves	523
handicapped	476	Regulators, pressure, hydronic	
rental	329	heating	539
Range circuit	543	Reinforcing	
Range hood	253, 254	bar supports	340
convertible	254	bars	89, 346, 365
custom	254	caissons	349
food service	455	chairs	348
vented	253	columns	349
Range support, cabinets	31	demolition	332
Ranges		fiber mesh	85
electrical work	129	foundation	346
gas, commercial	456	gunite	357
residential	255	masonry	215
		masonry ties	159
		mesh	91, 349
		mesh mini-mat	349
		pavement	244
		rings	348
		slabs	92, 346, 349
		splicing	348
		steel	89, 346
		steel, epoxy-coated	346
		stirrup	347
		tilt-up	362
		walkways	615
		welding	346
		Reinforcing ironworker, wage	
		industrial & commercial	309
		residential	10
		Relief valves	522, 539
		Relocatable structures,	
		manufactured type	480
		Remote high gain antenna	130
		Removal	
		asbestos	338
		clearing	594
		debris	337
		demolition	334
		lead-based paint	233, 435
		paving and curb	477
		PCBs	435
		radioactivity	435
		toxic chemicals	435
		tree	138, 594
		wallpaper	293
		Renderings, architectural	20, 126
		Rent, overhead	310
		Rental	
		backhoe	322
		bulldozer	323
		compactor	321
		compressor	320
		forklift	324
		landscape equipment	327
		miscellaneous equip.	329
		plumbing equipment	328
		road equipment	325
		scaffolding	329
		scaffolding, mobile	329
		Rental, equipment	320
		Report	
		home inspection	26
		soil test	279
		Reproduction, plans	25
		Residential	
		rules of thumb	307
		Residential wage rates	10
		Resilient flooring	153
		demolition	336
		installation	431
		Resilient hat channel, drywall	169
		Resorcinol glue	18
		Restaurant	
		equipment	453
		range	456
		Restrains, water heater	527
		Retaining wall forms	92, 341
		Retaining walls	375
		Return bends	516
		Reveal strips	
		formwork	342, 363
		tilt-up	363
		Reverse osmosis filters	529
		Revolving doors	416
		R-Gard insulation	182
		Ribbons (ribbands), carpentry	47
		Ridge	
		clay tile	261
		fiber cement	261
		flashing	260
		sheet metal roofing	260
		shingles	258, 259
		steel framing	72
		vents	292
		Ridgeboard, steel	72
		Rigid conduit	543
		Rigid insulation	182
		Ring steel reinforcing	348
		Ripping, excavation	596, 601
		Riprap	604
		Risers	
		concrete stair	95, 351, 360
		concrete stair, forming	346
		flagstone	216
		masonry	216
		rubber	220
		sprinkler heads	189
		stair	56, 283
		steel stairs	282
		wood stairs	281, 396
		RO filters, water	529
		Road	
		compaction	603
		equipment rental	325
		grading	596
		paving	610
		repairing	611
		rollers, rental	321
		striping	616
		trim and finish	603
		Road closed sign	22
		Road plate, steel	325
		Robe hooks	24
		Rock	
		aggregate	18
		cinder	604
		drain rock fill	604
		drilling	595
		drills, rental	320
		excavation	135
		fill	604
		ornamental	604
		recycling	332
		ripping	596, 601
		Rock fill drainage systems	126
		Rockwool insulation	183
		Rod clamps	554
		Rod hanger	554
		Rod, threaded	161
		Rods	
		lightning	129
		shower curtain	24
		Roll flashing	
		copper	267
		galvanized	268
		lead	269
		paper-backed copper	268
		ridge roll	260
		valley	268
		vinyl	270
		Roll roofing	401
		adhesive	258
		felt	257
		fiberglass	257
		mineral surface	257, 259
		papers	258
		Roller, dough	456
		Rollers, rental	321
		Rolling	
		ladders	459
		rolling platform lifts, rental	324
		rolling towers, rental	324
		Roll-up	
		doors	415
		window blinds	296
		Roll-up awning	21
		Romex cable	127, 542, 559
		Roof	
		apron	268
		bay window	304
		built-up	256
		cant strips	50, 182, 403
		coating	237, 256, 257, 401, 402
		cold, for log home	194
		deck cover	99
		deck, cementitious	403
		deck, concrete	369
		deck, steel	384
		deck, wood	392, 403

demolition	102	Rotary roof ventilators	292, 407	Running track	465	Sawing	
drains	525	Roto hammer, rental	326	Runoff protection	604	asphalt	371
edge	267, 268, 270	Rototilling	187, 623	Rust-converting metal primer	236	concrete	362, 370
edging	267	Rough carpentry		Rustic siding		masonry wall	370
EPDM	402	adhesive	18	cedar	199	Sawn posts, redwood	204
flashing	27, 268, 269	anchors	58	pine	200	Saws, rental	328
framing	36, 39, 47, 74	backing and nailers	47	Rust-inhibiting primer	234	wood	328
framing, panelized	392	beams	45	Ryegrass seeding	624	SBS	
framing, steel	70, 74	blocking	41			roll roofing	257
ice melting cable	561	bracing	44			starter strip	258
insulation	399	cant strips	50			Scaffolding	
insulation board	399	ceiling joists	46			caster-mounted, purchase	330
jacks	526	collar beams	48			erection	329
joists	392	collar ties	48			jacks	356
loading	262	columns	39			nails	231
membrane	256	columns, steel	57			planks, purchase	330
paint removal	233	curbs	48			rental	329
painting	240, 438	demolition	103, 334			safety equipment, purchase	330
pan	268	door openings	43			swinging, purchase	330
panels	392	dormer studs	48			Scaffolding, mobile	
paper	27	fascia	49			rental	329
patio	99	fireblocks	45			Scales, truck	452
safes	404	floor joists	40			ScapeWel window	305
sheathing	49, 392, 403	floor trusses	41			Schedule 40 PVC pipe	506
testing	316	furring	50			Schedule 80 PVC pipe	506
tile, concrete	261	girders	40			Scheduling	
trusses	48, 72, 395	grounds (stucco stop)	51			costs	311
trusses, piecework rates	38, 74	joists	46			CPM	134, 311
underlay	27	ledgers and ribbons	47			fees	134, 311
vent kit, bath	141	plates	42, 67			overhead	310
vent, turbine	141	posts	39, 45			School equipment	458, 467
vents	292	purlins	48			School network	459
windows	279	rafters	47			Scissor lifts	451
Roofer, wage		ribbons	47			Scissor lifts, rental	324
industrial & commercial	309	roof decking	50			Scoreboards, gym	464
residential	10	roof sheathing	49			Scoring concrete	356
Roofing		roof trusses	48, 49			Scrapers	
algae-resistant shingles	258	roof trusses	48, 49			excavation	601
asphalt	257, 258	sill plates	40, 57			rental	323
assemblies	37	stucco stop (grounds)	51			Scraping metal to prepare for	
base sheet	256, 257, 258	subflooring	42			painting	436
built-up	256, 401	trimmers	48			Scraping, paint	239
cant strips	50, 182, 403	wall sheathing	51			Scratch coat, plaster	244, 427
cement	256, 258	window openings	44			Screen	
clay tile	261	Rough hardware, plywood clips	162			concrete	362
concrete tile	261	Rough-in				concrete, rental	322
copper	404	appliances, gas	252			lath	188
corrugated	260, 400	bathtub	531			plaster or stucco	51
demolition	102	drinking fountain	531			rental	322
EPDM	402	floor drain	532			tilt-up	362
felt	257, 258, 401	lavatories	531			Screen	
fiber cement slate	261	service sink	531			bead molding	225
fiberglass panels	150	shower	531			block, masonry	215, 380
galvanized	260, 400	sink	531			masonry	380
gravel	256	toilet	530			ornamental	388
membrane	256	urinal	530, 531			patio door	121
metal	260	water closet	530			projection	458
nails, coil	230	Rough-sawn siding	275			sight	615
nails, galvanized	230	Round molding	225			solar	264
nails, plastic cap	231	Router-groover, rental	325			sun	388
paper	258	Routers, rental	328			tear-resistant (pet)	123
photovoltaic	280	RSC conduit	543			urinal	442
red cedar	259	Rub				vent	291, 292, 406
roll	257	carborundum	95, 356			window	300
rule of thumb costs	255	concrete finish	95, 356			wire	264
shake	259	Rubber				Screen doors	113
sheet	260	flooring	432			closers	105
sheet metal	260, 403	mats	220			hinges	172
shingles	259	studded tile	154			metal	113
slate	260	tile	432			security	113
solar	280	Rubber roof coating	402			vinyl	113
Spanish tile	261	Rubberized asphalt	611			wood	113
staples	231	Rubble, masonry	381			Screw guns, rental	327
steel panel	260	Rugs, carpet	76, 433			Screw shank nails	229
system	403	Rule of thumb costs				Screw-base lights	191
tar	256	carpentry	32			Screwdrivers, rental	327
tile	261	electrical work	127			Screwjacks, rental	329
Roof-mount power ventilator	142	hardware	420			Screws	
Roof-to-wall flashing	268	residential construction	307			drywall	229
Room dividers		roofing	255			self-tapping	150
doors, folding	444	steel framing	56			Scribe molding, cabinets	31
partitions	444	Runners	220, 473			Scrub sink	535
Rope climb, playground	467	mats	220			rough-in	531
Rosin sheathing	27	rubber	220				

S

Scully sink	457	switchboard	569	ducts	177	Shovels, earthwork.....	135
Sculpture screens	215	temporary connection.....	318	flashing.....	260, 267	Shower	
Scuppers, sheet metal.....	406	weatherproof.....	570	gutters, downspouts.....	167	caulk.....	78
Scuttle, roof.....	407	wire.....	557	hoods.....	270	compartments.....	442, 533
SDR 11 CPVC pipe.....	507	Service sinks	248, 534	roofing.....	260, 403	doors.....	271, 442
Seal coat		rough-in.....	531	siding.....	276, 400	emergency.....	531, 534
asphalt.....	243, 611	Service station		vents.....	406	enclosures.....	272
roadway.....	611	air and water.....	450	Sheet metal worker, wage		grab bars.....	247
Sealant pot, rental.....	325	cash box.....	450	industrial & commercial.....	309	handicapped access.....	247
Sealants		equipment.....	449	residential.....	10	mortar bed.....	272
caulking.....	77, 410	hydraulic hoist.....	450	Sheet piling.....	605	plumbing.....	533
caulking gun.....	79	submerged turbine.....	449	Sheet vinyl flooring.....	153, 431	receptors.....	272, 443, 533
concrete.....	77	turbine.....	449	adhesive.....	154	rod.....	24
deck.....	98	Serving fixtures.....	453	leveling compound.....	154	rough-in.....	531
door.....	78	Serving table, sushi.....	454	Sheetrock		seat.....	25
driveway.....	237	Settlement testing.....	279	gypsum drywall.....	168, 293, 423	stalls.....	246, 272, 443, 533
elastomeric.....	78	Sewage		painting.....	238, 241	stalls, cleaning.....	83
gutter and flashing.....	78	ejectors.....	265, 528	wallboard.....	168, 293, 423	Shower stalls.....	246
marine.....	78	leaks.....	266	Sheets		Shrinkage defined.....	3
paint.....	236	pumps.....	265	cork.....	435	Shrubs.....	625
primer.....	234	Sewer		polycarbonate.....	423	Shunt trip.....	571
siding.....	78	connection.....	266	polyethylene.....	253	Shutters	
silicon rubber.....	78	demolition.....	333	roofing.....	260	accordion-type.....	273
sill.....	182	pipe, PVC.....	630	Shelf lighting.....	191	Bahama-type.....	273
tub.....	79	pump systems, residential.....	265	Shelf, glass.....	270	colonial-type.....	273
wall.....	79	snakes, rental.....	328	Shellac		co-polymer.....	272
window.....	78	systems.....	265	floor finish.....	56	exterior.....	273
Seals, weatherstrip.....	294	Sewer lines.....	266	thinner.....	238	hurricane.....	273
Sealtite conduit.....	553	cleaning.....	630	Shelters		louvered.....	272
Seasonite wood preservative.....	237	demolition.....	333	bus stop.....	479	panel-type.....	273
Seat cover dispensers.....	445	Shacks, storage, rental.....	330	Shelters, prefabricated metal... 480		plywood.....	274
Seating		Shades		Shelves		roll-up.....	273
athletic.....	466	blinds.....	296	carpentry.....	55	Siamese connection.....	493
gym.....	464	cellular.....	297	closets.....	270	Sidelites	
school.....	458	Shades, window.....	296	industrial.....	448	steel door.....	111
shower.....	25	Shaft drilling, caisson		library.....	448, 472	Sidewalks	
stadium.....	474	foundations.....	608	linen cabinet.....	270	asphalt.....	615
theater.....	474	Shaft walls.....	427	storage.....	270	concrete.....	84, 94, 244, 611
Security		Shake felt.....	259	toilet.....	442	cover.....	331
access, keypad.....	590	Shakertown siding.....	276	utility.....	270	demolition.....	100, 101, 332
alarm systems.....	589	Shakes, roofing.....	259	wire.....	270	moving.....	490
alarms.....	264	Shale, excavation.....	596, 601	wood.....	270	Siding	
controls.....	591	Shaping slopes by hand.....	136	Shelving		aluminum.....	276, 400
gates, folding.....	115	She bolts.....	355	convenience store.....	485	cedar.....	199
gratings.....	388	Shear gate.....	627	display.....	485	corrugated.....	276, 400
grilles, doors.....	416	Shear panels		glass.....	270	demolition.....	102
guards.....	265	piecework rates.....	38	library.....	459	exterior trim.....	275
locks.....	171	steel framing.....	74	wire.....	270	fascia.....	275
monitor panels.....	589	Sheathing		Shims		fiber cement.....	274
systems.....	589, 591	adhesive.....	18	door.....	52	galvanized steel.....	276
television system.....	592	board.....	42, 51	shingles.....	259	hardboard lap.....	275
Security doors.....	113, 115	carpentry.....	62	stool.....	53	hardboard panel.....	274
Sediment control.....	604	carpentry piecework rates.....	76	stud.....	52	Hardi products.....	274
Sediment fence.....	604	clips.....	162	Shingles		insulated.....	400
Seeded aggregate finish... 244, 615		cork.....	435	algae-resistant.....	258	lap.....	201, 274
Seeding		demolition.....	102, 335	asphalt.....	255, 258	log cabin.....	200, 201
grass.....	624	Dens Glass.....	182	cedar.....	259	Nailite.....	277
landscaping.....	187, 624	floor.....	34, 38	demolition.....	102, 336	nails.....	231
Seekure paper.....	28	framing, steel.....	74	flashing.....	267, 268	OSB.....	275
Seesaws.....	468	gypsum board.....	168	hip and ridge.....	258	paint preparation.....	239
See-thru frames.....	418	insulated.....	182	laminate.....	258	paint removal.....	233
Seismic ties.....	161	insulation board.....	182, 399	painting.....	438	painting.....	240, 437, 438
Self-leveling compound.....	154	lumber.....	392	removal.....	336	pine.....	199, 200
Self-storing storm doors.....	114	OSB.....	42, 51, 391	roofing.....	258, 259	plywood.....	203, 275
Self-tapping screws.....	150	paper.....	27	siding.....	276	redwood.....	199
SensAire wall control switch... 141		piecework rates.....	39	slate.....	260	resin.....	277
Sensor cable, electric.....	589	plywood.....	42, 49, 51, 391	solar.....	280	sealant.....	78
Sensors		roof.....	49, 392, 403	starter strip.....	258	shingle.....	276
photoelectric.....	589	skip.....	395	wood.....	259	soffit vents.....	292
security.....	589	steel framing.....	61	wood, demolition.....	336	southern yellow pine.....	199
vibration.....	589	wall.....	51	Shoe molding.....	222, 223	thermoplastic.....	277
Septic		wall, exterior.....	391	Shoe, door.....	286	vinyl.....	276, 401
sewer systems.....	265	wall, interior.....	391	Shoring		western red cedar.....	199
tanks.....	529	wallboard.....	168, 293	beams.....	345	Sieve analysis, aggregate.....	314
Service doors.....	416	Sheds, storage, rental.....	331	concrete.....	605	Sieve, filter sock.....	126, 631
Service entrance.....	573	Sheepsfoot roller.....	138	equipment rental.....	330	Sight screen.....	615
cable.....	557	rental.....	139, 321	forms.....	345	Sign lighting.....	586
cap.....	544	Sheet glass.....	166, 422	heavy duty, rental.....	330	Sign numbers.....	172
connection.....	129	Sheet metal.....	403	trench.....	605	Signage, freestanding.....	485
		access doors.....	266	Shot fasteners.....	231, 390	Signal cable.....	592
						Signal crossing.....	486

Signs			
architectural signage	441	capillary fill	339
Braille	478	cast-in-place	369
directory	441	concrete	84, 352
display	441	demolition	336
elevator plates	479	edge forms	89
handicapped	478	finishes	95
job-type	318	floor	352
reflector	617	form, concrete	88
road closed	22	forms	340
safety	318	forms, elevated	345
street numbers	172	grading	339
temporary	310	membrane	94, 339
traffic	617	rebar	90
Silestone countertop	96	sand fill	339
Silicon carbide, sidewalk grits	356	tennis court	466
Silicon roofing	257	Slag	
Silicone caulk	78, 410, 411	crushed	126
Silicone roof		stone	18, 126
coating	402	Slate	
Sill		pavers	382
anchors	161	paving	614
blocks	378	roofing	260, 261
bolted	390	tile	287
carpentry	389	Slate roofing	
cover, aluminum	286	demolition	102
log	193	Sleepers, carpentry	51
mud	161	Sleeves, concrete	355
oak	286	Slicer, bread	456
plate gasket	182	Slide bolt lock	165
plates	40, 57, 192	Slides, playground	468
sealer	182	Sliding doors	
steel	387	aluminum	121
window	296	closers	105
Sill Seal™	182	fire	415, 416
Silt fence	150	glass	417
Simco walk top	243	glass, insulated	417
Simpson hangers	159	patio	121
Single-family home costs	306	pet door	123
Single-hung windows		screen	121
aluminum	301	vinyl	121
vinyl	297	wood	121
Sinkers, nails	228	Sliding windows	298, 302
Sinks		Slip-formed walls	353
bar	247	Slop sink rough-in	531
bases	290	Slope protection	604
bathroom	247, 533	Slopes, shaping, by hand	136
cabinets	29, 290, 473	Slump block	216
cabinets, cutout	31	Slurry seal	611
caulk	78	Small tool cost	310
demolition	337	Smart Panel siding	275
floor	535	Smoke detectors	128, 264
food service	457	Smoke vents	407
kitchen	248, 457, 531, 534	Snakes (sewer), rental	328
laundry	248	Snap ties	86, 355
marble	208	Snow block	193
mop	457, 534	Snow-melting cable	476, 561
scullery	457	Soap dishes	24
service	248, 534	ceramic	288
wash	531, 535	commercial	445
Siphon breaker, irrigation	189	Soap dispensers	445
Site work		demolition	337
clearing	594	Soccer goals	465
grading	596	Social Security payroll taxes	285
utilities, accessories	638	Sod	187, 624, 625
water meters	312	Sod cutters, rental	327
Sizing	293	Sodium lamp, high-pressure	586
Skid steer loaders, rental	323	Soffit	
Skid strips, stair	283	demolition	102
Skip sheathing	395	forms	346
Skiploader, rental	323	Hardie cement fiber	274
Skirtboard, carpentry	56	OSB	275
Skylights		plaster	244
fixed	278	steel	67
operable	278	systems	279
polycarbonate	277	vents	292
roof windows	279	vinyl	279
trimmers	48, 71	wood	46
Velux	277	Softball, backstops	618
Slab doors	107, 115, 116	Softener, plumbing fixtures	250
Slab-on-grade, concrete	94, 352	Software, project scheduling	311
Slabs			
base	94	Softwood	
		flooring	156
		plywood	202
		Soil	
		amendments	622
		cement treatment	603
		compaction	597, 599
		covers	603
		hauling	600
		loading	600
		moving by hand	602
		poisoning	280
		sealant	603
		spreading	597
		stabilization	603
		testing	26, 279
		treatments	280
		Soil pipe adapter	516
		Solar	
		barricade light	22
		collector system pump	528
		paneling	280
		power	582
		protection	471
		screen	264
		shingles	280
		water heating system	528
		water storage tank	528
		Solar Tek	291
		Solar window film	419
		Solariums	481
		Solenoid sprinkler valve	189
		Solid core doors	
		entry	107
		hardboard interior	116
		luan exterior	106
		prehung exterior	110
		steel	106
		Sonotube forms	344, 365
		Sound board	398
		Sound control	183
		Sound insulation board	182
		Sound reduction paneling	464
		Sound system, stage	463
		Soundness testing	314
		Soundproofing fabric	471
		Southern pine	
		fence	147, 148
		lumber	195, 196
		pressure-treated	202
		siding	203
		timber	202
		Southern yellow pine	
		decking	198
		flooring	197
		lumber	195
		posts	205
		pressure-treated	202
		siding	199
		timbers	202
		Spa enclosure	167
		Space frame steel	384
		Spackle	238
		Spades, clay, rental	320
		Spandrel glass	419, 422
		Spanish tile roofing	261
		Spar varnish	236
		Spark arrestor	152
		Special Construction, disabled	
		access	476
		Specialty lumber	205
		OSB	275
		Specific gravity	314
		Specifications fee	314
		Speed bumps	
		asphalt	610
		plastic	617
		Speed limit signs	617
		Spheres, painting	437
		Spikes	231
		Spiral	
		stairs, steel	385
		Spiral staircases	282
		Spirals, reinforcing	349
		Splash plate	255
		Splices, piles	608
		Splicing bars	348
		Split-face block	215, 379
		Split-rail fence	148
		Split-rib block	379
		Split-ring connectors	163
		Splitting rock	596
		Split-wired outlets	129
		Spotlight, fresnel	463
		Spray heads	
		sprinkler	621
		Spray painting	238
		deck	437
		metals	437
		steel	436
		Sprayed	
		fireproofing	409
		polyurethane insulation	184
		urethane insulation	184
		Sprayers, paint	239
		rental	328
		Spread footings	377
		Spreading soil	597
		Spreading soil by hand	136
		Springing	625
		Spring bronze	294
		Sprinkler fitter, wage	
		industrial and commercial	309
		residential	10
		Sprinkler system	188
		control	189
		Sprinklers	
		automatic	189
		components	492, 493
		connection	493
		control wiring	189
		fire	150
		heads	492, 621
		lawn	619
		pop-up heads	189
		subcontract	491
		trenching by hand	188
		valves	189
		wall hydrants	493
		Sprinkling, water for excavation	138
		Spruce	
		lap siding	201
		logs	192
		pine fir	195
		siding	201
		Square foot costs, homes	305-307
		Square molding	225
		Stabilization fabric	603, 604
		Stack, exhaust	581
		Stadium seating	474
		Stage	
		HVAC	464
		lighting	463
		sound system	463
		Stage curtains	462
		drawing equipment	463
		lift equipment	463
		Stain	
		concrete	235
		deck	98
		paint	237
		tinting	237
		wood finish	236
		Stained glass	470
		Staining	240, 241
		floor	156
		Stairlifts	133
		Stairs	
		aluminum	282
		attic	284
		baluster	56
		basement	23, 281
		box	281
		curved	281

disappearing	284	plate cutting	334	painting	241	Strawberry, ground cover	625
factory-cut	281	railing	253, 386	Steps-on-grade, concrete	95, 354	Street	
framing, piecework rates	38	reinforcing	89, 346	Sterilization, pipe	629	illumination	486
handrails	56	reinforcing, epoxy	346	Sterilizers, water	529	lighting	486
hardwood	281	reinforcing, foundation	346	Stick nails	229	lights	587
log	193	reinforcing, masonry	372	Stile & rail doors	117	marking	616
L-shaped	283	rod	161	Stirrup steel reinforcing	347	numbers, houses	172
moving	490	roof deck	384	Stock room door	418	paving	610
nosing, bamboo	158	roof framing	74	Stolons, grass	625	paving, equipment rental	325
rail	283	sag rods	383	Stone		sweeper	612
railing	281	sandblasting	263	aggregate	18	sweeper, rental	325
risers	56, 283	security gratings	388	aggregate base	609	Strip	
skirtboard	56	shoring	605	artificial	381	doors	418
spiral	282	stairs	282	base	94	flooring	55, 157
spiral, steel	385	stairs, spiral	385	cleaning	371	lighting	582
steel	282	stringers	385	countertop	96	shingle starter	258
straight	281	structural, fabrication	383	crushed	94, 126	Striper, rental	325
strips, anti-skid	283	testing	317	cut	381	Striping	
treads	56, 283	threaded rod	161	masonry	216	athletic courts	467
wood	281	tilt-up	364	paving	382	pavement	616
Stakes		wall framing	62	riprap	604	Striplights	582
form	205	welded wire	346	roofing	260	Stripping	
foundation	205	welding	389	slag	126	forms	89
steel	86	Steel doors		slate	260	soil, by hand	136
survey	205	entry	112	stepping	187, 625	Structural engineering	134
Stalls, shower	246, 272	exterior	110, 111	vanity tops	97	glazed tile	374
Stamped concrete	96	fire-rated	109	veneer	381	steel	383
Standard brick	209	garage	164	veneer, manufactured	381	Structural plywood	203
Standpipe connection	493	patio	121	work	381	Structural steel	
Stands, water heater	526	prehung	414	Stone tracking pad	604	fabrication	383, 388
Staplers, rental	327	screen	113	Stool		painting	436
Staples, roofing	231	Steel doors, fire-rated	109	carpentry	226	Structure moving	338
Starter strip		Steel framing		marble	381	Structures, temporary, rental	330
aluminum siding	276	anchors	58	window	53	Stucco	
galvanized flashing	268	backing for drywall	69	Stop signs	617	demolition	102, 337
shingles	258	beams	60	Stops		mesh	425
thermoplastic siding	277	blocking	61	door	171, 225, 420	mix	82
vinyl siding	276	bracing	67	gas	522	mold	108
Starter switches	567	ceilings	67	molding	108, 225	netting	188
Starters, motor	567	collar beams	72	Storage		paint	235
State cost adjustments	12-15	door opening	65	bins	310	painting	238, 241, 437
Steam		dormer studs	71	cabinets	473	plastering	244, 427
baseboard radiation	538	fascia, piecework	76	ice	457	wall assembly	35
bath generator wiring	128	floor joists	58	overhead	310	Stud grade lumber	194
bath, generators	285	girders	60	safes	262, 263	Studios, radio and television	488
cleaning	436	joists, ceiling	67	sheds	310	Studs	
cleaning, masonry	371	joists, piecework	73	sheds, rental	331	carpentry	389
condensate pipe	494	lally columns	57	shelving	448	demolition	104
generators	285	layout, piecework	73	Storefront windows	419	dormer	48
heating	538	piecework	73	Store-in-Door	114	exterior walls	35
Steam meter	524	purlins	72	Storm doors	114, 115	gable	37
Steamers, food service	454	rafters	70	full-view	114	interior walls	34
Steamers, wallpaper, rental	328	rafters, piecework	74	security	115	rule of thumb, steel framing	57
Steel		ridgeboard	72	self-storing	114	steel	62, 73
blocking	61	rule of thumb	56, 57	Storm drain demolition	333	steel exterior	63
buildings	483	sheathing, piecework	74, 76	Storm sewer		straightening	52
conduit, flexible	552	sill plates	57	cleaning	631	straps	163
conduit, rigid	543	square foot costs	57	Storm water control	604	wall assemblies	34
cutting and drilling	388	studs	62	Storm window	304	wall framing	37
doors	106	subflooring	61	Storm, plywood cover	274	walls, commercial	389
exterior walls	63	trimmers	71	StormGuard	27	Study carrels	459
floor joists	58	trusses	72, 73	Stoves, ovens, ranges		Stump grinders, rental	327
flooring	434	trusses, piecework	74	electrical work	129	Stump removal	138, 594
framing	56	wall plates	67	residential	255	Sturdi-Floor	203
framing, rule of thumb	57	walls, piecework	73	Strainers		Subbase, pavement	609
interior walls	62	window opening	66	bronze	539	Subcontract	
landings	385	Steel road plate, rental	325	hydronic	173, 539	driveway paving	243
lath	188	Steeple	485	wye-pattern	539	electrical work	127
lintels	387	Stem wall	93	Strand board	203	elevators	133
masonry	215	forms	340	Straps		fire sprinkler systems	491
mesh	91, 349	Stenographer	310	channel	555	hydroseeding	187, 624
mesh reinforcing	349	Step flashing	267, 268	conduit hanger	555	insulation	183
mini-mat reinforcing	349	Step lights	585	connectors	566	painting	239
ornamental	388	Stepping stones	187, 625	CPVC snap-on tubing	508	sprinkler systems	491
painted	388	Steps		hardware	163	stamped concrete	369
painting	436	brick	382	pipe	518	store front windows	419
panel roofing	260	concrete	95, 351, 354, 360	post anchor	219	surface preparation	239
piles	608	flagstone	216	tie	163	tile shower	246
pipe, black	494	manhole	636	Straw bales	187, 604	well drilling	295
pipe, carbon	494	masonry	216	Straw wattle	603	Subcontract costs defined	5

Subcontractor markup	5	meters	571	Tees		Tetherball post	468
Subflooring		transformers	571	ABS cleanout	515	Textolite countertops	96
2-4-1	203	weatherproof	570	ABS sanitary	514	Texture	
adhesive	18	Switches		black steel	494	popcorn ceiling	169
board	61	dimmer	564	copper	504	Texture 1-11	203
engineered	42	dimmer, fluorescent	564	copper DWV	512	Texture, drywall	169
floating	42	disconnect	577	CPVC	507	Textured wallboard	424
installation	42, 61	electric	129	PVC	506	Theater	
log homes	192	electrical	564	test	515	curtains	462
OSB	42, 62	exhaust fan	141	Wisconsin	514	seating	474
piecework rates	42	fan control	141	Telephone		Thermal	
plywood	42, 61	motor	567	outlets	591	analysis	184
Sturdi-Floor	203	power distribution	570	wiring	591	expansion tank	249
underlayment	203	safety	568, 569	Telephone assistance	5	insulation	397
Sub-panel connections	129	security	589	Telescoping doors	417	mitigation	471
Subsurface exploration	279	starter	568	Television		Thermal and Moisture	
Subway platform	487	timer, exhaust fan	141	closed circuit	592	Protection	397
Sump pumps	129, 528	wiring	129	educational	458	Thermoflow indicator	524
Sumps, roof	406	Swivel ring hangers, pipe	517	equipment	458	Thermography	184
Sun control blinds	296	Symbols		outlets	592	Thermometer, steam	524
Sun porch	167	lettering	467	pipe inspection	637	Thermoplastic	
Sun screens	388	Synthetic surface playing		studio	488	siding	277
Sunlamps, wiring	128	fields	465	systems	592	tape	467
Sunrooms	481			wiring	129	Thermostat	176
Super Jumbo Tex	27			Teller		Thermostatic	
Super Tuff-R	398			automatic	452	mixing valves	540
Superintendent	310, 314			counter	452	traps	540
Supervision costs	4, 314			window	453	water heaters	527
Supply valve	522			windows	452	THHN wire	558
Supports				Temperature gauge	524	Thinners	238
conduit	554			Tempering valves	540	Thompson's WaterSeal	236
fabricated metal	387			Temporary		Threaded	
PVC	551			enclosures	331	black steel pipe	494
Surface duct, electric	556			fence	331	carbon steel pipe	494
Surface preparation				jackposts	186	Threaded rod	161
.....233, 234, 239, 435, 437, 439				services	310	Thresholds	
Surgeons' scrub sink	535			structures	480	aluminum	285
rough-in	531			structures, rental	330	bamboo	158
Surveillance				utilities	318	bronze	421
camera	453			wall bracing	44, 67	high boy	108
park	486			Tennis courts		inserts	286
Survey				installation	466	marble	381
building layout	595			striping	466	wood	222
Survey stakes	205			windbreak panels	466	Thrust blocks, concrete	627
Surveying	313			Tension		Thru-the-wall utility fan	140
aerial	313			bridging	159	THWN wire	558
periodic	318			Termite shield	268	Ticket boxes	452
Sushi serving table	454			Termite treatment	207, 280	Ticket dispenser	450
Suspended ceiling	79, 429			Terra cotta, demolition	335	Tie straps	163
demolition	100, 336			Terrazzo		Tie wire	219
grid systems	79, 429			demolition	336	Tier IV EPA pollution	
light fixtures	80			pavers	382	control rating	581
panels	80, 81, 430			tile	382, 433	Ties	
T-bar grid	429			Test caps, plugs, and tees,		brick wall	219
tile	430			ABS	515	collar	48
Suspension grid, ceiling	79			Testimony, appraisal	18	concrete	355
Sweep pavement	612			Testing		concrete form	86, 355
Sweep, door bottom	287			acoustical	134	form	86, 339
Sweeper, rental	325			aggregate	314	hurricane	161
Swimming pool				asbestos	26	seismic	161
complete installation	475			asphalt	315	wall, brick	159
cover	476			brick	316	wall, masonry	210, 372
fences	150			building stone	316	Tile	
gunite	357			cable	130	acoustical facing	374
heaters, solar	250			concrete	315	backer board	290
paint	237, 438			fees	317	ceiling	82, 430
resurfacing	369			gunite	316	ceramic	374, 427
Swing check valves	521			hazards	26	clay	374
Swing gates, aluminum	165			home	26	concrete roof	261
Swinging stage scaffold,				masonry	316	decorative	288
purchase	330			network cable	460	demolition	101, 102, 336
Swings, playground	468			noise	134	epoxy bed	382
Switch box, electric	562			percolation	265	floor	287
circuits	575			piles	606	glazed	374
plates	23			soil	26, 265, 279, 314	installation	288, 289
Switch cover plate	565			sound transmission	134	marble	208
Switchboards	570			steel	317	masonry	220
accessories	571			thermal	184	porcelain	287
instrumentation	571			water	26	quarry	381, 429

resilient.....	432	Towel		Trench		Tubs	
roller, rental.....	326	bars.....	445	braces, rental.....	323	access doors.....	266
roofing.....	261	dispensers.....	445	covers.....	385	caulk strips.....	79
rubber.....	432	racks.....	24	frame.....	637	caulking.....	78
rubber studded.....	154	Towers		inlets.....	637	enclosures.....	272
saws, rental.....	328	fire pole, playground.....	469	shaping.....	597, 602	plumbing.....	245, 531, 533
security, glazed.....	374	lifting.....	319	sheeting.....	605	Tuck pointing.....	371
shock-absorbing.....	432	Toxic chemicals, removal.....	435	shields, rental.....	323	Tuff-R insulation.....	182
simulated roofing.....	260	Track		shoring.....	605	Tung oil wood finish.....	236
structural facing.....	374	railroad, demolition.....	334	sprinkler pipe.....	619	Turbines.....	579
vinyl floor.....	153, 154	rolling ladder.....	459	Trench plate, steel.....	325	additional costs.....	580
wall.....	287	stage curtain.....	462	Trenchers, rental.....	139, 323	fans.....	407
Tile layer, wage		Tracking pad, stone.....	604	Trenching.....	597	service station.....	449
industrial & commercial.....	309	Tractor		backhoe.....	597	vents.....	292
residential.....	10	demolition.....	335	concrete.....	338	vents, roof.....	141
Tile shower.....	246	excavation.....	596, 601	excavation.....	136, 597	Turf	
Tillers, rental.....	327	finish shaping.....	597	hand.....	136, 602	artificial grass.....	465
Tilt double-hung window.....	303	ripping rock.....	596	hand work.....	339	playing fields, grass and	
Tilt-up concrete.....	360	rock fill.....	604	rock.....	597	synthetic.....	465
Tilt-up construction.....	362	site clearing.....	594	sprinkler systems.....	188	replacing.....	619, 624
panels, sandblasting.....	263	site grading.....	596	Tri-Flex 30.....	27	Turfstone.....	615
pilasters.....	362	Tractor operator, wage,		Trim		Turfstone grass paving.....	615
Tilt-up painting.....	437	industrial & commercial.....	309	carpentry.....	226	Turnstiles.....	452, 487
Timbers		Traffic		door.....	53, 222	Turpentine.....	238
Douglas fir.....	201	cones.....	22	fireplace.....	55	Twinaxial cable.....	593
hardwood.....	396	control equipment rental.....	326	hardwood.....	222	Twist straps.....	164
laminated.....	396	control signage.....	318	molding.....	226	Type K copper pipe.....	503
lumber.....	197, 201	light.....	486	OSB siding.....	275	Type L copper pipe.....	503
pine.....	202	paint.....	237	painting.....	238, 240	Tyvek.....	28, 183
rafter.....	193	pavement marking.....	616	pine.....	226		
red cedar.....	201	signs.....	617	redwood.....	222		
redwood.....	201	stripes.....	616	softwood.....	223		
treatments.....	206	symbols.....	616	stair.....	56		
wood.....	396	Transaction		steel panel roofing.....	260		
Timekeeper costs.....	314	window.....	453	wallboard.....	169		
Timer switches.....	141, 564	Transformers.....	572	window.....	53		
15 minute.....	564	Trim coil.....	267	Trimmers			
Tin		Trimmers		carpentry.....	48		
ceilings.....	82	indoor.....	572	steel (framing).....	71		
shingles.....	268	pole mount.....	577	Trimming, trench bottom.....	136		
Tint		potential, switchboard.....	571	Triple-track storm doors.....	114		
paint.....	237	switchboard.....	571	Troffer lighting fixtures... 80, 190, 583			
wood finish.....	236	Transit levels, rental.....	327	Trowel finishing, concrete... 95, 356			
Tint, window.....	419	Transit mix concrete.....	84	Troweling machine, rental.....	321		
Tire changer.....	450	Transom lite.....	414	Trowel-ready mortar.....	219		
Tissue holder.....	24, 445	Trap adapter		Trowels, rental.....	321		
TJ truss joists.....	41, 395	ABS.....	516	Truck			
Toaster, conveyor type.....	456	copper.....	512	bucket.....	324		
Toggle switch.....	565, 568	Traps		bumpers.....	365		
Toilets.....	247, 532	float.....	540	concrete.....	350		
accessories.....	24, 445	thermostatic.....	540	cranes, rental.....	319		
augers, rental.....	328	Trash		excavation.....	138		
compartments.....	442	bins.....	332	hauling.....	600		
flush valves.....	532	chutes.....	337, 491	loading by hand.....	135		
jobsite.....	310	enclosure, tilt-up.....	366	rental.....	139, 324		
partition, handicapped.....	478	removal.....	310	scales.....	452		
partitions, demolition.....	337	Trash compactor wiring.....	130	superintendent's.....	310		
rough-in.....	530	Trash pumps, rental.....	324	water, rental.....	325		
temporary.....	310, 319	Travertine tile.....	287	Truck driver, wage			
trailer-mounted.....	319	Treads		industrial & commercial.....	309		
Tongue and groove		carpentry.....	56	residential.....	10		
flooring.....	155	concrete, finishing.....	356	Trusses			
insulation board.....	181	flagstone.....	216	fink.....	49, 72		
sheathing.....	51	marble.....	381	gable.....	49, 73		
siding.....	199	rubber.....	220	joists.....	395		
Tool sheds, rental.....	331	stair.....	283	log.....	193		
Tools available.....	4	wood.....	281, 396	roof.....	48, 72, 395		
Tools, rental.....	320	Treated lumber.....	201	roof, piecework.....	38		
Toothbrush holders		Treating		roof, piecework rates.....	74		
ceramic tile.....	288	lumber.....	207	steel.....	383		
residential.....	23	poles.....	204	Truss-type reinforcing.....	372		
Topping, concrete.....	95, 356	soil.....	280	Tub			
Topsoil		wood.....	207	sealant.....	79		
excavation, by hand.....	136	Treatment		whirlpool bath.....	245		
placement.....	187	fire retardant.....	207	Tube			
strip.....	595	soil poisoning.....	280	columns, steel.....	384		
Torch cutting.....	334	Tree clearing.....	138, 594	nosing.....	387		
Total column defined.....	5	Tree grates.....	626	pneumatic.....	491		
Total expense, overhead.....	310	Trees		Tubing			
		costs.....	625	copper.....	505		
		planting.....	624	electric metallic.....	544		
				strap, CPVC.....	508		

U

U bolts.....	518
Ultra Touch.....	183
Ultrasonic sensors and	
transceivers.....	590
Ultraviolet sterilizers, water.....	529
Underfloor duct.....	557
Underground	
communication.....	541
duct.....	541
power.....	541
Underlayment.....	203, 262, 432
floor.....	34
particleboard.....	395
piecework rates.....	38, 74
roof.....	27
tile backer board.....	290
Underpinning, shoring.....	605
Unions	
black steel.....	494
CPVC.....	507
Unistrut inserts.....	355
Unit heaters.....	535, 538
Uniturf.....	465
Unusual labor productivity.....	4
URD wire.....	558
Urethane	
exterior finish.....	236
floor finish.....	56
insulation.....	184
sealer.....	155
sheathing.....	182
Urinal	
floor-mounted.....	531
rough-in.....	530, 531, 532
screens.....	442
screens, removal.....	337
wall-hung.....	530
water-conserving.....	532
Urns.....	473
USE wire.....	558
Using this book.....	3
Utilities.....	626
overhead.....	310
sewer connections.....	266
sitework piping.....	268
temporary.....	318
water.....	312

testing	26	rebar	348	painting	238, 239, 241	systems	591
treatment	529	steel	389	partition	443	telephone	591
trucks, rental	325	tilt-up	364	picture	299	twisted pair	591
wells	295	Weld-o-lets	499	reglazing	239	Wisconsin tee	514
Water closets		Welfare costs	3	removal	337	Wolmanized lumber	207
commercial	532	Well drilling, subcontract	295	roof	279, 304	Wonderboard tile backer	290
demolition	478	Wellpoint dewatering	602	screen	300	Wood	
installation	478	Wenge cabinets	472	seals	294	fences	148
residential	247	West coast fir lumber	194, 196	security grill	485	filler	238
rough-in	530	Western red cedar siding	199	shades	296	finishes	236
Water heater		Wet paint barricade	23	sills	296	floor finishing	56, 430
accessories	526	Wet patch roof cement	256, 257	skylights	277	flooring	55, 155, 430
leak detection	527	Wet sandblasting	263	steel	419	flooring adhesive	159
tankless	249	Wheel corner guards	387	stool, marble	381	lumber	207
Water heaters		Wheel loader		stool, MDF	226	paint preparation	239
assemblies	527	rental	138	stool, wood	226	piles	606
commercial	526	Wheel loaders	598	storm	304	preservative	207, 237
connections	527	rental	139	teller	452	roofing	259
earthquake restraints	527	Wheelbarrow		treatment	296	sealer	236
electric	249, 527	hauling debris	337	trim	53, 226	shingles	259
gas	248	hauling soil	602	vinyl	297, 298, 299, 300	stain	236
instantaneous	527	Wheelbarrows, rental	327	vinyl bay	299	treatment, lumber	207
overflow pans	526	Wheelchair		vinyl casement	299	waterproofing	236
propane	249	lifts	133	vinyl double-hung	297, 298	Wood and composites	389
residential	249	ramp	476	vinyl garden	299	Wood chip mulch	187
safety pans	526	swing platform	468	vinyl hopper	300	Wood doors	
solar	249, 528	Whirlpool bathtubs	245	vinyl jalousie	299	patio	121
stands	526	wiring	128	vinyl picture	299	screen	113
wiring	130	White board	440	vinyl single-hung	297	Woodcore storm doors	115
Water meter	524	White cement	82, 427, 433	vinyl sliding	298	Woodwork	
Water table		White roof coating	257	vinyl-clad awning	300	paint preparation	239
flashing	268	Whiteboard (chalkboard)	440	vinyl-clad basement	301	painting	241
molding	222, 224	Whitewash stain	237	vinyl-clad casement	300, 301	staining	241
Water-based stain	236	Whole house fans	141	vinyl-clad wood	300, 301	waxing	241
Waterblasting	239, 371	Wilsonart countertops	96	wall	422	Woodworking glue	18
Watering		Wind clips	262	weatherstripping	294	Work tables	
embankment grading	597	Wind turbines	132	wood	419	food service	454
landscaping	621	Windbreak, tennis	466	Wingwall	638	kitchen	454
sprinkler systems	621	Window		Wiping stain	237	Workers' comp insurance	185
trenching	619	plywood cover	274	Wire		Working conditions	4
Waterproof adhesive	18	removal	103	building	127	Woven wire partitions	444
Waterproofing	294	teller	453	copper	558	Wrecking, demolition	104
acrylic	184	transaction	453	electric	127	Wrenches, rental	328
asphalt	397	Window air conditioners	177	ground	558	Wrought iron	150
building	382	Window wells	305	lath	188	railing	386
concrete	294, 339	Window, safety film	419	partitions	444	W-valley flashing	267, 268
insulation	184	Window, tint film	419	Romex	559	Wye pattern strainers	173, 539
masonry	218, 235, 294	Windows		screen	264	Wyes	
membrane	397	aluminum single-hung	301	service entrance	129, 557	ABS	514
multi-surface	237	aluminum sliding	302	shelving	270	drain pipe	126
paper	27	apron	53	sprinkler	620		
slab	339	architectural	419	THHN, copper	558		
walkways	294	awning	21, 300	URD	558		
wood finish	236	awning, aluminum	302	USE	558		
WaterSeal wood sealer	236	bank	452	XHHW, copper	559		
Waterstop, concrete	91, 349	basement	301	Wire brush			
Wattmeter	571	bay	299	finish	95		
Waxing		blinds	272	painting	439		
concrete	356	bow, wood	304	Wire glass	418		
floors	238, 431	casement	299, 300, 301	Wire mesh	91		
woodwork	241	casing	54	fence	143		
Weather vanes	97	caulking	78	gunite	357		
Weatherproof		circular, vinyl	299	reinforcing	91		
service entrance	570	cleaning	83, 331	Wireless access points	130		
switchboards	570	coverings	273	Wire mold raceway	556		
Weatherproofing	27	double-hung	303	Wireway, electrical	556		
wood finish	236	fixed	299	Wiring			
Weatherstripping	294, 421	frames, paint removal	233	alarms	264		
Wedge tie, concrete form	355	framing	44	campus network	459		
Wedges	205	framing, steel	66	computer	130, 459		
Weed eaters, rental	327	garden	299	control wiring	189		
Welded		glass	166	controllers	189		
black steel pipe	494	grating	388	doorbell	105		
carbon steel pipe	494	impact	301	educational network	459		
mesh	91	jalousie	299	electric	127		
wire mesh	349	mantels	295	fence, electric	144		
Welding		octagonal	303	irrigation controls	189		
grounding	565	paint preparation	239	landscape sprinklers	189		
machines, rental	329			phones	591		

X

Xerographic prints	25
XHHW wire	559
X-ray	
barriers	484
lead mesh fabric	471
mobile barriers	484
protection	484
viewing panels	484

Y

Yard	
deck	100
lighting	587
Yardarm, nautical	449
Yellow pine lumber	195
Yield signs	617

Z

Z-bar flashing	267, 268
Z-brick	243
Zinc primers	234
Zone	
heating and cooling	178
Zone valves	492

Practical References for Builders

National Estimator Cloud



Generate professional construction estimates for all residential and commercial construction from your internet browser. Includes 10 Craftsman construction cost databases, over 40,000 labor and material costs for construction, in an easy-to-use format. Cost estimates are well-organized and thoroughly indexed to speed and simplify writing estimates for nearly any residential or light commercial construction project – new construction, improvement or repair. Convert the bid to an invoice – in either QuickBooks Desktop or QuickBooks Online. Access your estimates from anywhere and on any device with a Web browser. **Just \$9.49 a month.** Visit <https://craftsman-book.com/national-estimator-cloud> for more details.

National Painting Cost Estimator



A complete guide to estimating painting costs for just about any type of residential, commercial, or industrial painting, whether by brush, spray, or roller. Shows typical costs and bid prices for fast, medium, and slow work, including material costs per gallon, square feet covered per gallon, square feet covered per manhour, labor, material, overhead, and taxes per 100 square feet, and how much to add for profit. Includes a free download of

an electronic version of the book, with *National Estimator*, a stand-alone *Windows™* estimating program. Additional information and *National Estimator ShowMe* tutorial is available on our website under the “Support” dropdown tab. **448 pages, 8½ x 11, \$98.00. Revised annually**

Also available as an eBook (PDF), \$49.00 at www.craftsman-book.com

Paper Contracting: The How-To of Construction Management Contracting

Risk, and the headaches that go with it, have always been a major part of any construction project — risk of loss, negative cash flow, construction claims, regulations, excessive changes, disputes, slow pay — sometimes you'll make money, and often you won't. But many contractors today are avoiding almost all of that risk by working under a construction management contract, where they are simply a paid consultant to the owner, running the job, but leaving him the risk. This manual is the how-to of construction management contracting. You'll learn how the process works, how to get started as a CM contractor, what the job entails, how to deal with the issues that come up, when to step back, and how to get the job completed on time and on budget. Includes a link to free downloads of CM contracts legal in each state. **272 pages, 8½ x 11, \$55.50**

Also available as an eBook (PDF), \$27.75 at www.craftsman-book.com

Electrician's Exam Preparation Guide to the 2017 NEC

Need help in passing the apprentice, journeyman, or master electrician's exam? This is a book of questions and answers based on actual electrician's exams administered over the last few years in states and counties across the U.S. Almost a thousand multiple-choice questions — exactly the type you'll find on the exam — cover every area of electrical installation: electrical drawings, services and systems, transformers, capacitors, distribution equipment, branch circuits, feeders, calculations, measuring and testing, and more. It gives you the correct answer, an explanation, and where to find it in the latest NEC. Also tells how to apply for the test, where to get your application form, how best to study, and what to expect on examination day. **352 pages, 8½ x 11, \$67.99**

Also available as an eBook (PDF), \$33.99 at www.craftsman-book.com

eBooks also available for 2008, 20011 and 2014

Fences & Retaining Walls Revised eBook

Everything you need to know to run a profitable business in fence and retaining wall contracting. Takes you through layout and design, construction techniques for wood, masonry, and chain link fences, gates and entries, including finishing and electrical details. How to build retaining and rock walls. How to get your business off to the right start, keep the books, and estimate accurately. The book even includes a chapter on contractor's math.

400 pages. Available only as an eBook (PDF, EPUB & MOBI/Kindle); \$23.00 at www.craftsman-book.com



Construction Forms for Contractors



This practical guide contains 78 practical forms, letters and checklists, guaranteed to help you streamline your office, organize your jobsites, gather and organize records and documents, keep a handle on your subs, reduce estimating errors, administer change orders and lien issues, monitor crew productivity, track your equipment use, and more. Includes accounting forms, change order forms, forms for customers, estimating forms, field work forms, HR forms, lien forms, office forms, bids and proposals, subcontracts, and more. All are also on the CD-ROM included, in Excel spreadsheets, as formatted Rich Text that you can fill out on your computer, and as PDFs.

360 pages, 8½ x 11, \$48.50

Also available as an eBook (PDF), \$24.25 at www.craftsman-book.com

Plumber's Handbook Revised

This new edition explains simply and clearly, in non-technical, everyday language, how to install all components of a plumbing system to comply not only with recent changes in the *International Plumbing Code* and the *Uniform Plumbing Code*, but with the requirements of the *Americans with Disabilities Act*. Originally written for working plumbers to assure safe, reliable, code-compliant plumbing installations that pass inspection the first time, *Plumber's Handbook*, because of its readability, accuracy and clear, simple diagrams, has become the textbook of choice for numerous schools preparing plumbing students for the plumber's exams. Now, with a set of questions for each chapter, full explanations for the answers, and with a 200-question sample exam in the back, this handbook is one of the best tools available for preparing for almost any plumbing journeyman, master or state-required plumbing contracting exam.

384 pages, 8½ x 11, \$44.50

eBook (PDF) also available; \$22.25 at www.craftsman-book.com

Steel-Frame House Construction eBook

Framing with steel has obvious advantages over wood, yet building with steel requires new skills that can present challenges to the wood builder. This book explains the secrets of steel framing techniques for building homes, whether pre-engineered or built stick by stick. It shows you the techniques, the tools, the materials, and how you can make it happen. Includes hundreds of photos and illustrations, plus a FREE download with steel framing details and a database of steel materials and manhours, with an estimating program. **320 pages.**

Only available as an eBook (PDF), \$19.88 at www.craftsman-book.com

CD Estimator

If your computer has *Windows™* and a CD-ROM drive, CD Estimator puts at your fingertips over 150,000 construction costs for new construction, remodeling, renovation & insurance repair, home improvement, framing & finish carpentry, electrical, concrete & masonry, painting, earthwork & heavy equipment and plumbing & HVAC. Quarterly cost updates are available at no charge on the Internet. You'll also have the *National Estimator* program — a stand-alone estimating program for *Windows™* that *Remodeling* magazine called a “computer wiz,” and *Job Cost Wizard*, a program that lets you export your estimates to *QuickBooks Pro* for actual job costing. A 60-minute interactive video teaches you how to use this CD-ROM to estimate construction costs. And to top it off, to help you create professional-looking estimates, the disk includes over 40 construction estimating and bidding forms in a format that's perfect for nearly any *Windows™* word processing or spreadsheet program. **CD Estimator is \$149.50**

National Renovation & Insurance Repair Estimator

Current prices in dollars and cents for hard-to-find items needed on most insurance, repair, remodeling, and renovation jobs. All price items include labor, material, and equipment breakouts, plus special charts that tell you exactly how these costs are calculated. Includes a free download of an electronic version of the book with *National Estimator*, a stand-alone *Windows™* estimating program. Additional information and *National Estimator ShowMe* tutorial is available on our website under the “Support” dropdown tab.

488 pages, 8½ x 11, \$99.50. Revised annually

Also available as an eBook (PDF), \$49.75 at www.craftsman-book.com



Excavation & Grading Handbook Revised



The foreman's, superintendent's and operator's guide to highway, subdivision and pipeline jobs: how to read plans and survey stake markings, set grade, excavate, compact, pave and lay pipe on nearly any job. Includes hundreds of informative, on-the-job photos and diagrams that even experienced pros will find invaluable. This new edition has been completely revised to be current with state-of-the-art equipment usage and the most efficient excavating and grading techniques. You'll learn how to read topo

maps, use a laser level, set crows feet, cut drainage channels, lay or remove asphaltic concrete, and use GPS and sonar for absolute precision. For those in training, each chapter has a set of self-test questions, and a Study Center CD-ROM included has all 250 questions in a simple interactive format to make learning easy and fun. **512 pages, 8½ x 11, \$59.00**

Also available as an eBook (PDF), \$29.50 at www.craftsman-book.com

Construction Contract Writer



Relying on a "one-size-fits-all" boilerplate construction contract to fit your jobs can be dangerous — almost as dangerous as a handshake agreement. *Construction Contract Writer* lets you draft a contract in minutes that precisely fits your needs and the particular job, and meets both state and federal requirements. You just answer a series of questions — like an interview — to construct a legal contract for each project you take on. Anticipate where disputes could arise and settle them in the contract before they happen. Include the warranty protection you intend, the payment schedule, and create subcontracts from the prime contract by just clicking a box. Includes a feedback button to an attorney on the Craftsman staff to help should you get stumped — *No extra charge.* **\$149.95.**

Download the *Construction Contract Writer* at:
<http://www.constructioncontractwriter.com>

Markup & Profit: A Contractor's Guide, Revisited

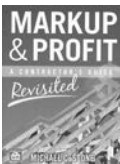

In order to succeed in a construction business, you have to be able to price your jobs to cover all labor, material and overhead expenses, and make a decent profit. But calculating markup is only part of the picture. If you're going to beat the odds and stay in business — profitably, you also need to know how to write good contracts, manage your crews, work with subcontractors and collect on your work.

This book covers the business basics of running a construction company, whether you're a general or specialty contractor working in remodeling, new construction or commercial work. The principles outlined here apply to all construction-related businesses. You'll find tried and tested formulas to guarantee profits, with step-by-step instructions and easy-to-follow examples to help you learn how to operate your business successfully. Includes a link to free downloads of blank forms and checklists used in this book. **336 pages, 8½ x 11, \$52.50**

Also available as an eBook (ePub, mobi for Kindle), \$39.95 at www.craftsman-book.com

Roofing Construction & Estimating



Installation, repair and estimating for nearly every type of roof covering available today in residential and commercial structures: asphalt shingles, roll roofing, wood shingles and shakes, clay tile, slate, metal, built-up, and elastomeric. Covers sheathing and underlayment techniques, as well as secrets for installing leakproof valleys. Many estimating tips help you minimize waste, as well as insure a profit on every job. Troubleshooting techniques help you identify the true source

of most leaks. Over 300 large, clear illustrations help you find the answer to just about all your roofing questions. **448 pages, 8½ x 11, \$38.00**
eBook (PDF) also available, \$19.00 at www.craftsman-book.com

Concrete Construction

Just when you think you know all there is about concrete, many new innovations create faster, more efficient ways to do the work. This comprehensive concrete manual has both the tried-and-tested methods and materials, and more recent innovations. It covers everything you need to know about concrete, along with Styrofoam forming systems, fiber reinforcing adjuncts, and some architectural innovations, like architectural foam elements, that can help you offer more in the jobs you bid on. Every chapter provides detailed, step-by-step instructions for each task, with hundreds of photographs and drawings that show exactly how the work is done. To keep your jobs organized, there are checklists for each stage of the concrete work, from planning, to finishing and protecting your pours. Whether you're doing residential or commercial work, this manual has the instructions, illustrations, charts, estimating data, rules of thumb and examples every contractor can apply on their concrete jobs. **288 pages, 8½ x 11, \$28.75**
Also available as an eBook (PDF), \$14.38 at www.craftsman-book.com

Standard Estimating Practice, 10th edition

Estimating isn't always an easy job. Sometimes snap decisions can produce negative long-term effects. This book was designed by the American Society of Professional Estimators as a set of standards to guide professional estimators. It's intended to help every estimator develop estimates that are uniform and verifiable. Every step that should be included in the estimate is listed, as well as aspects in the plans to consider when you're estimating a job, and what you should look for that may not be included. The result should help you produce more consistently accurate estimates. **852 pages, 8½ x 11, \$99.95**

Craftsman's Construction Installation Encyclopedia

Step-by-step installation instructions for just about any residential construction, remodeling or repair task, arranged alphabetically, from *Acoustic tile to Wood flooring*. Includes hundreds of illustrations that show how to build, install, or remodel each part of the job, as well as manhour tables for each work item so you can estimate and bid with confidence. Also includes a CD-ROM with all the material in the book, handy look-up features, and the ability to capture and print out for your crew the instructions and diagrams for any job. **792 pages, 8½ x 11, \$65.00**

Also available as an eBook (PDF), \$32.50 at www.craftsman-book.com

National Building Cost Manual

Square-foot costs for residential, commercial, industrial, military, schools, greenhouses, churches and farm buildings. Includes important variables that can make any building unique from a cost standpoint. Quickly work up a reliable budget estimate based on actual materials and design features, area, shape, wall height, number of floors, and support requirements. Now includes free download of Craftsman's easy-to-use software that calculates total in-place cost estimates or appraisals. Use the regional cost adjustment factors provided to tailor the estimate to any jobsite in the U.S. Then view, print, email or save the detailed PDF report as needed.

280 pages, 8½ x 11, \$88.00. Revised annually

Also available as an eBook (PDF), \$44.00 at www.craftsman-book.com



National Electrical Estimator

This year's prices for installation of all common electrical work: conduit, wire, boxes, fixtures, switches, outlets, loadcenters, panelboards, raceway, duct, signal systems, and more. Provides material costs, manhours per unit, and total installed cost. Explains what you should know to estimate each part of an electrical system. Includes a free download of an electronic version of the book with *National Estimator*, a stand-alone *Windows™* estimating program. Additional information and *National Estimator ShowMe* tutorial is available on our website under the "Support" dropdown tab. **552 pages, 8½ x 11, \$97.75. Revised annually**

Also available as an eBook (PDF), \$48.88 at www.craftsman-book.com

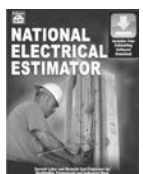

Estimating & Bidding for Builders & Remodelers

This 5th edition has all the information you need for estimating and bidding new construction and home improvement projects. It shows how to select jobs that will be profitable, do a labor and materials take-off from the plans, calculate overhead and figure your markup, and schedule the work. Includes a CD with an easy-to-use construction estimating program and a database of 50,000 current labor and material cost estimates for new construction and home improvement work, with area modifiers for every zip code. Price updates on the Web are free and automatic.

272 pages, 8½ x 11, \$89.50

Also available as an eBook (PDF), \$44.75 at www.craftsman-book.com

Estimating Home Building Costs, Revised

Estimate every phase of residential construction from site costs to the profit margin you include in your bid. Shows how to keep track of manhours and make accurate labor cost estimates for site clearing and excavation, footings, foundations, framing and sheathing finishes, electrical, plumbing, and more. Provides and explains sample cost estimate worksheets with complete instructions for each job phase. This practical guide to estimating home construction costs has been updated with digital *Excel* estimating forms and worksheets that ensure accurate and complete estimates for your residential projects. Enter your project information on the worksheets and *Excel* automatically totals each material and labor cost from every stage of construction to a final cost estimate worksheet. Load the enclosed CD-ROM into your computer and create your own estimate as you follow along with the step-by-step techniques in this book.

336 pages, 8½ x 11, \$38.00

Also available as an eBook (PDF), \$19.00 at www.craftsman-book.com



Builders Guide to Swimming Pool Construction

Break into the lucrative swimming pool construction business with this practical how-to guide. Here you'll learn how to get the permits and do the surveying, planning and layout for a typical pool, including how to read a soils report. You'll read about the excavation, backfill, soil compaction, sand and gravel bedding and drainage requirements, and mechanical systems such as pumps, heaters, filters, skimmers, and solar systems. Covers underground piping, including drain, supply, and gas; and electrical work, including grounding and supply to breaker, pump, underwater lighting, and heater. Shows wood and pre-fabricated metal forms for walls, steps, spas, equipment base and diving board base, and how to install bar and mesh steel reinforcement. Covers cast-in-place and sprayed concrete and modern pool finishes. Includes scheduling, and a section on estimating labor, material and equipment costs.

240 pages, 8½ x 11, \$49.95. Published by Builder's Book, Inc.

National Home Improvement Estimator



Current labor and material prices for home improvement projects. Provides manhours for each job, recommended crew size, and the labor cost for removal and installation work. Material prices are current, with location adjustment factors and free monthly updates on the Web. Gives step-by-step instructions for the work, with helpful diagrams, and home improvement shortcuts and tips from experts. Includes a free download of an electronic version of the book, and *National Estimator*, a stand-alone *Windows™* estimating program. Additional information and *National Estimator ShowMe* tutorial is available on our website under the "Support" dropdown tab.

568 pages, 8½ x 11, \$98.75. Revised annually

Also available as an eBook (PDF), \$49.38 at www.craftsman-book.com

Estimating Excavation Revised eBook



How to calculate the amount of dirt you'll have to move and the cost of owning and operating the machines you'll do it with. Detailed, step-by-step instructions on how to assign bid prices to each part of the job, including labor and equipment costs. Also, the best ways to set up an organized and logical estimating system, take off from contour maps, estimate quantities in irregular areas, and figure your overhead. This revised edition includes a chapter on earthwork estimating software. As with any tool, you have to pick the right one. Written by an experienced dirt contractor and instructor of computer estimating software, this chapter covers the program types, explains how they work, gives the basics of how to use them, and discusses what will work best for the type of work you handle. This eBook is the download version of the book in text searchable, PDF format. Craftsman eBooks are for use in the freely distributed Adobe Reader and are compatible with Reader 6.0 or above. **550 pages**

Only available as eBook (PDF) \$21.75 at www.craftsman-book.com

Builder's Guide to Accounting Revised

Step-by-step, easy-to-follow guidelines for setting up and maintaining records for your building business. This practical guide to all accounting methods shows how to meet state and federal accounting requirements, explains the new depreciation rules, and describes how the Tax Reform Act can affect the way you keep records. Full of charts, diagrams, simple directions and examples to help you keep track of where your money is going. Recommended reading for many state contractor's exams. Each chapter ends with a set of test questions, and a CD-ROM included FREE has all the questions in interactive self-test software. Use the Study Mode to make studying for the exam much easier, and Exam Mode to practice your skills. **360 pages, 8½ x 11, \$43.00**

Also available as an eBook (PDF), \$21.50 at www.craftsman-book.com

Insurance Restoration Contracting: Startup to Success

Insurance restoration — the repair of buildings damaged by water, fire, smoke, storms, vandalism and other disasters — is an exciting field of construction that provides lucrative work that's immune to economic downturns. And, with insurance companies funding the repairs, your payment is virtually guaranteed. But this type of work requires special knowledge and equipment, and that's what you'll learn about in this book. It covers fire repairs and smoke damage, water losses and specialized drying methods, mold remediation, content restoration, even damage to mobile and manufactured homes. You'll also find information on equipment needs, training classes, estimating books and software, and how restoration leads to lucrative remodeling jobs. It covers all you need to know to start and succeed as the restoration contractor that both homeowners and insurance companies call on first for the best jobs. **640 pages, 8½ x 11, \$69.00**

Also available as an eBook (PDF), \$34.50 at www.craftsman-book.com



Building Code Compliance for Contractors & Inspectors

An answer book for both contractors and building inspectors, this manual explains what it takes to pass inspections under the 2009 *International Residential Code*. It includes a code checklist for every trade, covering some of the most common reasons why inspectors reject residential work — footings, foundations, slabs, framing, sheathing, plumbing, electrical, HVAC, energy conservation and final inspection. The requirement for each item on the checklist is explained, and the code section cited so you can look it up or show it to the inspector. Knowing in advance what the inspector wants to see gives you an (almost unfair) advantage. To pass inspection, do your own pre-inspection before the inspector arrives. If your work requires getting permits and passing inspections, put this manual to work on your next job. If you're considering a career in code enforcement, this can be your guidebook.

8½ x 11, 232 pages, \$32.50

Also available as an eBook (PDF), \$16.25 at www.craftsman-book.com



National Repair & Remodeling Estimator

The complete pricing guide for dwelling reconstruction costs. Reliable, specific data you can apply on every repair and remodeling job. Up-to-date material costs and labor figures based on thousands of jobs across the country. Provides recommended crew sizes; average production rates; exact material, equipment, and labor costs; a total unit cost and a total price including overhead and profit. Separate listings for high- and low-volume builders, so prices shown are specific for any size business. Estimating tips specific to repair and remodeling work to make your bids complete, realistic, and profitable. Includes a free download of an electronic version of the book with *National Estimator*, a stand-alone *Windows™* estimating program. Additional information and *National Estimator ShowMe* tutorial is available on our website under the "Support" dropdown tab.

528 pages, 8½ x 11, \$98.50. Revised annually

Also available as an eBook (PDF), \$49.25 at www.craftsman-book.com



Pipe & Excavation Contracting Revised

This popular manual has been updated and improved to bring it more current with modern earthmoving and trenching equipment, refined excavation techniques, stricter safety rules, and improved materials. Shows how to read plans and compute quantities for both trench and surface excavation, figure crew and equipment productivity rates, estimate unit costs, bid the work, and get the bonds you need. Learn how to choose the right equipment for each job, use GPS, how to lay all types of water and sewer pipe, work on steep slopes or in high groundwater, efficiently remove asphalt and rock, and the various pipe, joints and fittings now available. Explains how to switch your business to excavation work when you don't have pipe contracts, and how to avoid the pitfalls that can wipe out your profits on any job. **328 pages, 8½ x 11, \$42.50**

Also available as an eBook (PDF), \$21.25 at www.craftsman-book.com

Moving to Commercial Construction

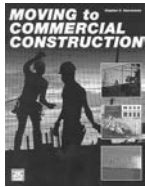

In commercial work, a single job can keep you and your crews busy for a year or more. The profit percentages are higher, but so is the risk involved. This book takes you step-by-step through the process of setting up a successful commercial business: finding work, estimating and bidding, value engineering, getting through the submittal and shop drawing process, keeping a stable work force, controlling costs, and promoting your business. Explains the design/build and partnering business concepts and their advantage over the competitive bid process. Includes sample letters, contracts, checklists and forms that you can use in your business, plus a CD-ROM with blank copies in several word-processing formats for both Mac™ and PC computers.

256 pages, 8½ x 11, \$42.00

Also available as an eBook (PDF), \$21.00 at www.craftsman-book.com

Profits in Buying & Renovating Homes



Step-by-step instructions for selecting, repairing, improving, and selling highly profitable “fixer-uppers.” Shows which price ranges offer the highest profit-to-investment ratios, which neighborhoods offer the best return, practical directions for repairs, and tips on dealing with buyers, sellers, and real estate agents. Shows you how to determine your profit before you buy, what “bargains” to avoid, and how to make simple, profitable, inexpensive upgrades.

304 pages, 8½ x 11, \$24.75

Craftsman eLibrary



Craftsman's eLibrary license gives you immediate access to 60+ PDF eBooks in our bookstore for 12 full months!

You pay only one low price. \$129.99.

Visit www.craftsman-book.com for more details.

International Residential Code (IRC) 2018 Fast-Tabs

User-friendly International Residential Code (IRC) Tabs are a great way to organize the IRC 2018. These self-adhesive tabs can reduce the time spent searching to find key information. Tabs are durable and allow for positioning adjustments after being placed on the code paper. Affordable and time-saving, these are a must-have for IRC users. Can also be used with loose-leaf version.

8 x 5½, \$15.95. Published by Builder's Book, Inc.

International Building Code (IBC) Quick-Card: Based on 2018 IBC

In this unique, 6-page laminated quick-reference guide, you get all the International Building Code (IBC) essentials you need to know based on the current 2018 IBC. The scope of the International Building Code (IBC) includes all buildings except detached one- and two-family dwellings and townhouses up to three stories. Featured sections: Foundations & Footings, Concrete, Floor Framing, Wall Framing, Roof Framing, Interior Dimensions, Means of Egress, Fire & Smoke Protection, Safety Glazing, Handrails, Stairways & Guards, Masonry.

6 pages, 8½ x 11, \$9.95. Published by Builder's Book, Inc.

International Building Code (IBC) 2018 Fast-Tabs

User-friendly International Building Code (IBC) Tabs are a great way to organize the IBC 2018. These self-adhesive tabs can reduce the time spent searching to find key information. Tabs are durable and allow for positioning adjustments after being placed on the code paper. Affordable and time-saving, these are a must-have for IBC users. Can also be used with Loose-leaf version.

8 x 5½, \$15.95. Published by Builder's Book, Inc.

Estimating Electrical Construction Revised



Estimating the cost of electrical work can be a very detailed and exacting discipline. It takes specialized skills and knowledge to create reliable estimates for electrical work. See how an expert estimates materials and labor for residential and commercial electrical construction. Learn how to use labor units, the plan take-off, and the bid summary to make an accurate estimate, how to deal with suppliers, use pricing sheets, and modify labor units. This book provides extensive labor unit tables and blank forms on a CD for estimating your next electrical job.

272 pages, 8½ x 11, \$59.00

Also available as an eBook (PDF), \$29.50 at www.craftsman-book.com

Construction Estimating Reference Data

Provides the 300 most useful manhour tables for practically every item of construction. Labor requirements are listed for sitework, concrete work, masonry, steel, carpentry, thermal and moisture protection, doors and windows, finishes, mechanical and electrical. Each section details the work being estimated and gives appropriate crew size and equipment needed. Includes a certificate for a FREE download of an electronic version of the book with *National Estimator*, a stand-alone Windows™ estimating program. **384 pages, 11 x 8½, \$59.00**

Also available as an eBook (PDF), \$29.50 at www.craftsman-book.com

Contractor's Guide to QuickBooks by Online Accounting

This book is designed to help a contractor, bookkeeper and their accountant set up and use QuickBooks Desktop specifically for the construction industry. No use re-inventing the wheel, we have used this system with contractors for over 30 years. It works and is now the national standard. By following the steps we outlined in the book you, too, can set up a good system for job costing as well as financial reporting.

156 pages, 8½ x 11, \$68.50

OSHA Construction Safety Essentials Quick-Card

This extended, 6-page guide covers the OSHA Construction Safety Essentials. Great for contractors, builders, architects and engineers... anyone who needs a quick overview of the basics involved in this key construction issue. Featured sections: Personal Protective Equipment (PPE), Construction Site — Fall Protection — Openings, Scaffolding Safety, Site Safety — Ladders & Stairways, Excavation & Trench Safety, Electrical Safety, Hazard Communication.

6 pages, 8½ x 11, \$9.95. Published by Builder's Book, Inc.

Renovating & Restyling Older Homes

Any builder can turn a run-down old house into a showcase of perfection — if the customer has unlimited funds to spend. Unfortunately, most customers are on a tight budget. They usually want more improvements than they can afford — and they expect you to deliver. This book shows how to add economical improvements that can increase the property value by two, five or even ten times the cost of the remodel. Sound impossible? Here you'll find the secrets of a builder who has been putting these techniques to work on Victorian and Craftsman-style houses for twenty years. You'll see what to repair, what to replace and what to leave, so you can remodel or restyle older homes for the least amount of money and the greatest increase in value.

416 pages, 8½ x 11, \$33.50

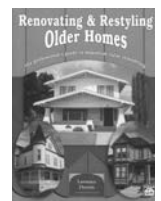

National Appraisal Estimator

An Online Appraisal Estimating Service. Produce credible single-family residence appraisals — in as little as five minutes. A smart resource for appraisers using the cost approach. Reports consider all significant cost variables and both physical and functional depreciation. For more information, visit

www.craftsman-book.com/national-appraisal-estimator-online-software



Insurance Replacement Estimator



Insurance underwriters demand detailed, accurate valuation data. There's no better authority on replacement cost for single-family homes than the *Insurance Replacement Estimator*. In minutes you get an insurance-to-value report showing the cost of re-construction based on your specification. You can generate and save unlimited reports. For more details, visit www.craftsman-book.com/insurance-replacement-estimator-online-software

National Plumbing & HVAC Estimator

Manhours, labor and material costs for all common plumbing and HVAC work in residential, commercial, and industrial buildings. You can quickly work up a reliable estimate based on the pipe, fittings and equipment required. Every plumbing and HVAC estimator can use the cost estimates in this practical manual. Sample estimating and bidding forms and contracts also included. Explains how to handle change orders, letters of intent, and warranties. Describes the right way to process submittals, deal with suppliers and subcontract specialty work. Includes a free download of an electronic version of the book with National Estimator, a stand-alone Windows™ estimating program. Additional information and *National Estimator ShowMe* tutorial is available on our website under the "Support" dropdown tab.

480 pages, 8½ x 11, \$98.25. Revised annually
eBook (PDF) also available, \$49.13 at www.craftsman-book.com

The Art of Roof Cutting Series DVD Library - Basic DVD

You don't have to climb the walls, to learn to raise a roof! Steve Peters has been a framing contractor in Southern California for 14 years as well as a framer for more than 20 years. In this 120-minute video, Steve will share with you his extensive knowledge on the art of cutting and assembling these roofs. **\$79.95**

The Art of Roof Cutting Series DVD Library - Advanced DVD

In this Advanced Edition DVD video, expert framing contractor Steve shares his extensive knowledge on the art of cutting and assembling roofs. Used in Technical Schools and highly recommended by Building Contractors. **\$79.95**

Wood-Frame House Construction

Step-by-step construction details, from the layout of the outer walls, excavation and formwork, to finish carpentry and painting. Packed with clear illustrations and explanations updated for modern construction methods. Everything you need to know about framing, roofing, siding, interior finishings, floor covering and stairs — your complete book of wood-frame homebuilding.

320 pages, 8½ x 11, \$25.50. Revised edition

How to Succeed With Your Own Construction Business

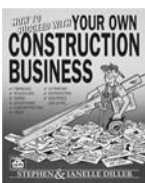

Everything you need to start your own construction business: setting up the paperwork, finding the jobs, advertising, using contracts, dealing with lenders, estimating, scheduling, finding and keeping good employees, keeping the books, and coping with success. If you're considering starting your own construction business, all the knowledge, tips, and blank forms you need are here. **336 pages, 8½ x 11, \$28.50**

eBook (PDF) also available, \$14.25 at www.craftsman-book.com

Shear Walls & Sheathing Lateral Loads Quick-Card (Bldrs Book)

This 6-page card quickly covers the construction essentials you need in loads and shear walls based on the new 2021 International Residential Code (IRC) for loads, shear walls & sheathing. Special sections focus on specific essentials for each area of framing. **6 pages, 8½ x 11, \$9.95**

Residential Wood Framing Const. Quick-Card (Bldrs Book)

This 6-page laminated card covers the construction essentials for wood framing based on the new 2021 International Residential Code (IRC). **6 pages, 8½ x 11, \$9.95**

Planning Drain, Waste & Vent Systems

How to design plumbing systems in residential, commercial, and industrial buildings. Covers designing systems that meet code requirements for homes, commercial buildings, private sewage disposal systems, and even mobile home parks. Includes relevant code sections and many illustrations to guide you through what the code requires in designing drainage, waste, and vent systems. **192 pages, 8½ x 11, \$39.95**

Basic Engineering for Builders

This book is for you if you've ever been stumped by an engineering problem on the job, yet wanted to avoid the expense of hiring a qualified engineer. Here you'll find engineering principles explained in non-technical language and practical methods for applying them on the job. With the help of this book you'll be able to understand engineering functions in the plans and how to meet the requirements, how to get permits issued without the help of an engineer, and anticipate requirements for concrete, steel, wood and masonry. See why you sometimes have to hire an engineer and what you can undertake yourself: surveying, concrete, lumber loads and stresses, steel, masonry, plumbing, and HVAC systems. This book is designed to help you, the builder, save money by understanding engineering principles that you can incorporate into the jobs you bid.

400 pages, 8½ x 11, \$39.50
eBook (PDF) also available; \$19.75 at www.craftsman-book.com

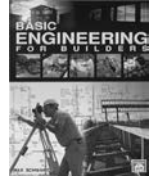

Home Building Mistakes & Fixes

This is an encyclopedia of practical fixes for real-world home building and repair problems. There's never an end to "surprises" when you're in the business of building and fixing homes, yet there's little published on how to deal with construction that went wrong - where out-of-square or non-standard or jerry-rigged turns what should be a simple job into a nightmare. This manual describes jaw-dropping building mistakes that actually occurred, from disastrous misunderstandings over property lines, through basement floors leveled with an out-of-level instrument, to a house collapse when a siding crew removed the old siding. You'll learn the pitfalls the painless way, and real-world working solutions for the problems every contractor finds in a home building or repair jobsite. Includes dozens of those "surprises" and the author's step-by-step, clearly illustrated tips, tricks and workarounds for dealing with them.

384 pages, 8½ x 11, \$52.50
eBook (PDF) also available, \$26.25 at www.craftsman-book.com



National Electrical Code Quick-Card 2020 NEC (Bldrs Book)

In this unique, 6-page laminated quick-reference guide, you get all the National Electrical Code (NEC) essentials you need to know based on the current 2020 NEC. **6 pages, 8½ x 11, \$9.95**

Contractor's Math Short Cuts Quick-Cards

In this single, 4-page laminated card, you get all the math essentials you need in contracting. The formulas and rules of thumb for calculating dimensions, surface areas, volume, etc. **4 pages, 8½ x 11, \$7.95**

Drywall Essentials Quick Cards

This extended, 6-page guide covers the basics of the Drywall. Great for contractors, property owners... anyone who needs a quick overview of the basics involved in this key building phase. **6 pages, 8½ x 11, \$7.95**

Residential Construction Foundation 2018 Quick-Card

An improperly constructed foundation will adversely affect the entire structure. But there are far too many details, measurements and rules — all code-enforced — to trust to memory. This handy 6-page guide provides at a glance the precise details and code requirements of this critical phase in residential construction. Based on the 2018 IRC. **6 pages, 8½ x 11, \$7.95**

Handbook of Construction Contracting, Vol. 1

Volume 1: Everything you need to know to start and run your construction business; the pros and cons of each type of contracting, the records you'll need to keep, and how to read and understand house plans and specs so you find any problems before the actual work begins. All aspects of construction are covered in detail, including all-weather wood foundations, practical math for the job site, and elementary surveying.

416 pages, 8½ x 11, \$32.75

Handbook of Construction Contracting, Vol. 2

Volume 2: Everything you need to know to keep your construction business profitable, including estimating methods, controlling costs, concrete, masonry, rough carpentry, roof covering, insulation, doors and windows, exterior finishes, specialty finishes, scheduling, managing workers, marketing, spec building and land development.

320 pages, 8½ x 11, \$33.75

Now you can generate professional estimates from your internet browser with National Estimator Cloud.

Just 9.49/month. Cancel anytime - Subscribe today!

<https://craftsman-book.com/national-estimator-cloud>



Craftsman Book Company
6058 Corte del Cedro
Carlsbad, CA 92011

Call me.
1-800-829-8123
Fax (760) 438-0398

Name _____

e-mail address (for order tracking and special offers) _____

Company _____

Address _____

City/State/Zip _____ This is a residence

Total enclosed _____ (In California add 7.5% tax)

*Free Media Mail shipping, within the US,
when your check covers your order in full.*

10-Day Money Back Guarantee

In A Hurry?

We accept phone orders charged to your

Visa, MasterCard, Discover or American Express

Card# _____

Exp. date _____ CVV# _____ Initials _____

Tax Deductible: Treasury regulations make these references tax deductible when used in your work. Save the canceled check or charge card statement as your receipt.

Order online www.craftsman-book.com
Free on the Internet! Download any of Craftsman's estimating costbooks for a 30-day free trial! www.craftsman-book.com

Prices subject to change without notice

- 39.50 Basic Engineering for Builders
- 43.00 Builder's Guide to Accounting Revised
- 49.95 Builder's Guide to Swimming Pool Construction
- 32.50 Building Code Compliance for Contractors & Inspectors
- 149.50 CD Estimator
- 28.75 Concrete Construction
- 59.00 Concrete Estimating Reference Data
w/FREE *National Estimator* Download
- 48.50 Construction Forms for Contractors
- 68.50 Contractor's Guide to QuickBooks by Online Accounting
- 7.95 Contractor's Math Short Cuts Quick-Cards
- 65.00 Craftsman's Construction Installation Encyclopedia
- 7.95 Drywall Essentials Quick Cards
- 67.99 Electrician's Exam Prep Guide to the 2017 *NEC*
- 89.50 Estimating & Bidding for Builders & Remodelers
- 59.00 Estimating Electrical Construction Revised
- 38.00 Estimating Home Building Costs, Revised
- 59.00 Excavation & Grading Handbook Revised
- 32.75 Handbook of Construction Contracting Volume 1
- 33.75 Handbook of Construction Contracting Volume 2
- 52.50 Home Building Mistakes & Fixes
- 28.50 How to Succeed With Your Own Const. Business
- 69.00 Insurance Restoration Contracting: Startup to Success
- 15.95 International Building Code (IBC) 2018 Fast-Tabs
- 9.95 Internat'l Building Code Quick-Card: Based on 2018 IBC
- 15.95 International Residential Code (IRC) 2018 Fast-Tabs
- 52.50 Markup & Profit: A Contractor's Guide, Revisited
- 42.00 Moving to Commercial Construction
- 88.00 Natl Building Cost Manual w/FREE download of
Craftsman's easy-to-use software
- 9.95 National Electrical Code Quick-Card 2020
- 97.75 Natl Electrical Estimator w/FREE *Natl Estimator* Download
- 98.75 Natl Home Improvement Est w/FREE *Natl Estimator* Download
- 98.00 Natl Painting Cost Estimator w/FREE *Natl Estimator* Download
- 98.25 Natl Plumbing & HVAC Estimator w/FREE *Natl Estimator*
Download
- 99.50 Natl Renovation & Insurance Repair Estimator
w/FREE *Natl Estimator* Download
- 98.50 Natl Repair & Remodeling Est w/FREE *Natl Estimator* Download
- 9.95 OSHA Construction Safety Essentials Quick-Card
- 55.50 Paper Contracting:
The How-To of Construction Management Contracting
- 42.50 Pipe & Excavation Contracting Revised
- 39.95 Planning Drain, Waste & Vent Systems
- 44.50 Plumber's Handbook Revised
- 24.75 Profits in Buying & Renovating Homes
- 33.50 Renovating & Restyling Older Homes
- 7.95 Residential Construction Foundation 2018 IRC Quick-Card.
- 9.95 Residential Wood Framing Construction Quick-Card
- 79.95 Roof Cutting DVD: Advanced
- 79.95 Roof Cutting DVD: Basic
- 38.00 Roofing Construction & Estimating
- 9.95 Shear Walls & Sheathing Lateral Loads Quick-Card
- 99.95 Standard Estimating Practice
- 25.50 Wood Frame House Construction
- 97.50 Natl Construction Est w/FREE *Natl Estimator* Download